



# İçindekiler

## Index

### Inhaltsverzeichnis



<b>Genel Bilgiler</b> General Info. Einführung	<b>İçindekiler</b>	<i>Index</i>	<b>Inhaltsverzeichnis</b>	
	<b>Sembollerin Açıklaması</b>	<i>Key of Symbols</i>	Erklärung der Bezeichnungen	01
	<b>Ürün Yelpazesi</b>	<i>Production Range</i>	Produktpalette	03
	<b>E Serisi Redüktörlerin Genel Özellikleri</b>	<i>General Specifications of E Series Gearboxes</i>	Allgemeine Eigenschaften Von E Serie Getrieben	04
	<b>Teknik Tanımlamalar</b>	<i>Technical Explanations</i>	Technische Erläuterungen	06
	<b>Teknik Özellikler</b>	<i>Technical Specifications</i>	Technische Informationen	07
	<b>Aksesuarlar</b>	<i>Accessories</i>	Zubehör	07
	<b>Tip Tanımlaması</b>	<i>Unit Designation</i>	Typenbezeichnungen	08
	<b>Örnek Tip Tanımlamaları</b>	<i>Sample Designations</i>	Typenbezeichnungsbeispiele	10
	<b>Redüktör Çıkış Özelliği</b>	<i>Gearbox Output Specification</i>	Eigenschaft der Ausgang	14
	<b>Moment kolu Pozisyonları</b>	<i>Torque Arm Positions</i>	Stelle Von Drehmomentstütze	15
	<b>Redüktör Dönüş Yönleri</b>	<i>Direction of Rotation</i>	Getriebedrehrichtungen	16
	<b>Motor Büyüklüğüne Göre Geometrik Mümkün Çevrim Oranı Kombinasyonları</b>	<i>Geomet. Possible Combinations of Ratios According to Motor Size</i>	Geomet. Mögliche Kombi. von Übersetz. nach Motorbaugröße	17
	<b>Servis Faktörü</b>	<i>Service Factor</i>	Betriebsfaktor	18
	<b>Yük Sınıflandırması</b>	<i>Load Classification</i>	Belastungsart	19
	<b>Radyal Yükler</b>	<i>Overhung Loads</i>	Querkräfte	20
	<b>Radyal Yüklerin Hesabı</b>	<i>Calculation Of Overhung Loads</i>	Berechnung der Querkräfte	22
	<b>Sonsuz Vidalarda Termik Güç</b>	<i>Thermal Power for Worm Gearboxes</i>	Thermische Leistung für Schneckenradgetriebe	23
	<b>Verim</b>	<i>Efficiency</i>	Wirkungsgrad	24
	<b>Sonsuz Vidada Otoblokajlık</b>	<i>Irreversibility by Wormgears</i>	Schneckengetrieb Selbsthemmung	25
	<b>Eşdeğer Güç Hesabı</b>	<i>Equivalent Power Calculation</i>	Äquivalente Leistung	26
	<b>Eşdeğer Güç Hesabı Örneği</b>	<i>Equivalent Power Cal. Example</i>	Beispiel für Äquivalente Leistung	27
	<b>Redüktör Seçimi</b>	<i>Gearbox Selection</i>	Getriebeauswahl	28
	<b>Redüktör Seçim Formu</b>	<i>Gearbox Selection Form</i>	Formular für Getriebeauswahl	29
	<b>Yağlama</b>	<i>Lubrication</i>	Schmierung	31
	<b>Yağ Tipleri</b>	<i>Oil Types</i>	Schmierstoffe	34
	<b>Montaj Pozisyonları</b>	<i>Mounting Positions</i>	Bauformen	35
	<b>Yağ Miktarları</b>	<i>Oil Quantities</i>	Ölmengen Tabellen	36

E0100-0612



# İçindekiler

## Index

### Inhaltsverzeichnis



<b>Motorlar</b> <i>Motors</i> Motor	<b>AC Motorlar</b>	<i>AC Motors</i>	Drehstrommotoren	38
	<b>a- Genel Özellikler</b>	<i>a- General Spec. of AC Motors</i>	a-Eigensch. des Drehstrommotors	38
	<b>b- Çalışma Türleri</b>	<i>b-Modes of Operation</i>	b-Betriebsarten	39
	<b>c- Koruma Sınıfı</b>	<i>c- Protection Class</i>	c- Schutzarten	40
	<b>d- İzolasyon Sınıfı</b>	<i>d- Insulation Class</i>	d- Isolationsklasse	40
	<b>e- Verim Sınıfları</b>	<i>e- Efficiency Classes</i>	e- Energieeffizienzklassen	40
	<b>f- AC Frekans İntertörler</b>	<i>f- AC Frequency Inverters</i>	f- AC Frequenz Umrichter	41
	<b>DC Motorlar</b>	<i>DC Motors</i>	DC Motoren	42
	<b>a- Genel Özellikler</b>	<i>a- General Specif. of DC Motors</i>	a- Eigenschaften von DC Motoren	42
	<b>b- DC Motorların Çalışma İlkeleri</b>	<i>b- Operating principals of DC Motors</i>	b- Funktionsprinzip der DC Motoren	42
	<b>c- DC Motor Çeşitleri</b>	<i>c- Types of DC Motors</i>	c- Arten von DC Motoren	42
	<b>d- DC Motorlarda Hız Kontr.</b>	<i>d- Speed Control of DC motors</i>	d- Drehzahl Kontrolle DC Motoren	42
<b>Frenler</b> <i>Brakes</i> Bremsen	<b>Elektromanyetik Frenler</b>	<i>Electromagnetic Brakes</i>	Elektromagnetische Bremsen	43
<b>Güç Devir Tabl.</b> <i>Perform. Tables</i> Leistung-Drehahl Tabellen.	<b>Motorlu Güç Devir Tabloları</b>	<i>Geared Motors Performance Tables</i>	Getriebeleistung und drehzahl Übersicht	47
	<b>Motorsuz Güç Devir Tabloları</b>	<i>Gear Units Performance Tables</i>	Getriebe Leistung und Drehzahl-übersicht	147
<b>Ölçü Sayfaları</b> <i>Dimension Pages</i> Abmesungs Tabellen	<b>EV Serileri</b>	<i>EV Series</i>	EV Serie	68
	<b>EN Serileri</b>	<i>EV Series</i>	EV Serie	114
	<b>ET Serileri</b>	<i>ET Series</i>	ET Serie	165
<b>Mil ve Kovan Ölçüleri</b> <i>Shaft and Hollow Shaft Dimensions</i> Wellen und Gehäusemaße	<b>Mil Flanş Ağırlıkları</b>	<i>Shaft and Flange Weights</i>	Wellen und Flansch Gewichte	211
	<b>Moment Kolu</b>	<i>Torque Arm</i>	Drehmomentstütze	212
	<b>E Serisi Kovan Ölçüleri</b>	<i>E Series Hollow Shaft Dimensions</i>	Gehäuseabmessungen von E Serie Getriebe	213
	<b>Tavsiye edilen müşteri mil montaj demontaj şekli ve aksesuarları</b>	<i>Advised Customer Shaft Dimensions and Accessories</i>	Empfohlene wellen massn und verbindungs-elemente Bei montage	214
	<b>Mil Muhafaza Kapağı</b>	<i>Shaft Protection Cover</i>	Wellenversteck Deckel	215



# Genel Bilgiler

## General Information

### Einführung



#### Sembollerin Açıklaması

$c_t$ .....: Anahtarın devreye girme zamanı katsayısı

$f_s$ .....: Servis faktörü

$F_{ama}$ .....: Çıkış milinde müsaade edilen eksenel yükler [kN]

$F_{ame}$ .....: Giriş milinde müsaade edilen eksenel yükler [kN]

$F_{qam}$ .....: Çıkış milinde izin verilen radyal yöndeki yükler [N]

$F_{qem}$ .....: Giriş milinde izin verilen radyal yöndeki yükler [N]

$F_{qa}$ .....: Çıkış miline gelen radyal yöndeki yükler [N]

$F_{qe}$ .....: Giriş miline gelen radyal yöndeki yükler [N]

$F_q$ .....: Çıkış miline gelen radyal yöndeki yükler [N]

$F_a$ .....: Çıkış miline gelen eksenel yöndeki yükler [N]

$i$ .....: Tahvil oranı

$J_{ext}$ .....: Motor miline indirgenmiş toplam dış atalet momenti [kgm<sup>2</sup>]

$M_2$ .....: Çıkış momenti [Nm]

$M_a$ .....: Anma momenti [Nm]

$n_1$ .....: Redüktör giriş mili devri [d/dak]

$n_2$ .....: Redüktör çıkış mili devri [d/dak]

$P_{eq}$ .....: Eşdeğer güç [kW]

$P_e$ .....: Nominal güç (Bak. Güç-Devir Tabloları) [kW]

$P_M$ .....: Tahrik edilecek makina için gerekli güç (Değişken yükler için eşdeğer güç alınır) [kW]

$t$ .....: Zaman [s]

$T_e$ .....: Eşdeğer moment [Nm]

$P_{N2}$ .....: Çıkış gücü [kW]

$P_{N1}$ .....: Giriş gücü [kW]

#### Key of Symbols

$c_t$ .....: Coefficient of switch on time.

$f_s$ .....: Service factor

$F_{ama}$ .....: Permissible axial loads which can be applied to output shaft. [kN]

$F_{ame}$ .....: Permissible axial loads which can be applied to input shaft. [kN]

$F_{qam}$ .....: Permissible overhung loads which can be applied to output shaft. [N]

$F_{qem}$ .....: Permissible overhung loads which can be applied to input shaft. [N]

$F_{qa}$ .....: Overhung loads applied to the output shaft [N]

$F_{qe}$ .....: Overhung loads applied to the input shaft. [N]

$F_q$ .....: Overhung loads on output shaft [N]

$F_a$ .....: Axial loads on output shaft [N]

$i$ .....: Transmission ratio

$J_{ext}$ .....: The total inertia of rotating parts at outside reduced at the motor shaft [kgm<sup>2</sup>]

$M_2$ .....: Output torque [Nm]

$M_a$ .....: Nominal torque [Nm]

$n_1$ .....: Input speed of gearbox [rpm]

$n_2$ .....: Output speed of gearbox [rpm]

$P_{eq}$ .....: Equivalent power [kW]

$P_e$ .....: Nominal power (given on performance tables) [kW]

$P_M$ .....: Required power for the driven machine (for alternating power, refer to equivalent power) [kW]

$t$ .....: Time [s]

$T_e$ .....: Equivalent torque [Nm]

$P_{N2}$ .....: Output Power [kW]

$P_{N1}$ .....: Input Power [kW]

#### Erklärung der Bezeichnungen

$c_t$ .....: Koeffizient der Tätigkeitszeit von Schalter

$f_s$ .....: Betriebsfaktor

$F_{ama}$ .....: Zulässige Axialkräfte auf Abtriebswelle [kN]

$F_{ame}$ .....: Zulässige Axialkräfte auf Antriebswelle [kN]

$F_{qam}$ .....: Zulässige Querkräfte auf Abtriebswelle [N]

$F_{qem}$ .....: Zulässige Querkräfte auf Antriebswelle [N]

$F_{qa}$ .....: Querkräfte auf Abtriebswelle [N]

$F_{qe}$ .....: Querkräfte auf Antriebswelle [N]

$F_q$ .....: Querkräfte auf Abtriebswelle [N]

$F_a$ .....: Querkräfte auf Antriebswelle [N]

$i$ .....: Übersetzungsverhältnis

$J_{ext}$ .....: Die Gesamtträgheit der rotierende Teile von der Ausgangsseite reduziert auf Motorwelle [kgm<sup>2</sup>]

$M_2$ .....: Ausgangsdrehmoment [Nm]

$M_a$ .....: Nenndrehmoment [Nm]

$n_1$ .....: Antriebsdrehzahl [U/min]

$n_2$ .....: Abtriebsdrehzahl [U/min]

$P_{eq}$ .....: Äquivalente Leistung [kW]

$P_e$ .....: Getriebe Nennleistung (siehe Leistung- Drehzahl tabellen) [kW]

$P_M$ .....: Leistung benötigt an der Abtriebswelle (Zur Berechnung bei variabler Leistungen äquivalente Leistung benutzen) [kW]

$t$ .....: Zeit [s]

$T_e$ .....: Minimales Drehmoment [Nm]

$P_{N2}$ .....: Ausgangsleistung [kW]

$P_{N1}$ .....: Eingangsleistung [kW]



# Genel Bilgiler

## General Information

### Einführung



#### Ürün Yelpazesi

Elinizdeki katalog sadece **E serisi** ürünleri içermektedir.

##### - M ve N Serisi

Helisel alın dişliye sahip, giriş ve çıkış milleri aynı düzlem üzerinde ve birbirine paralel uzanan, üzerlerinde bulunan ayak veya flanş ile makina-ya sabitlenen redüktörlerdir. Dolu mil çıkışıdır.

##### - D Serisi

Helisel alın dişliye sahip, giriş ve çıkış milleri aynı düzlem üzerinde, birbirine paralel ve belirli bir aralıkta yerleştirilmiş, iki yan yüzde bulunan bağlantı civataları, flanş veya tork kolu ile makina-ya sabitlenen redüktörlerdir. Delik milli veya mil çıkışı olabilir.

##### - E Serisi

Sonsuz vida ve çark dişlili, belirli bir aralıkta ve birbirine dik konumlandırılmış giriş ve çıkış millerine sahip, çepçevre konumlandırılmış ayak bağlantıları, flanş veya tork kolu ile makina-ya sabitlenen redüktörlerdir. Delik milli veya mil çıkışı olabilir.

##### - Y Serisi

Yatık tip redüktörler, ağır şartlarda çalışmak üzere dizayn edilmiş redüktör tipleridir. Bu tiplerde redüktör ile bunu tahrik eden mekanizma arasında değişik bağlantı şekilleri mevcuttur (Mekanik ve hidrolik kaplinler, çeşitli tip kayışlar ve zincirle tahrik gibi). Delik milli veya mil çıkışı olabilir.

##### - K Serisi

Helisel alın dişli ve konik dişlilerden oluşan, birbirine dik ve belirli bir aralıkta konumlandırılmış giriş ve çıkış milline sahip, çepçevre sunulan ayaklar, flanş veya tork kolu ile makina-ya sabitlenen redüktörlerdir. E serisinden farklı olarak yüksek verime sahiptirler. Delik milli veya mil çıkışı olabilir.

##### - H ve B Serisi

Helisel ve/veya konik dişliye sahip ağır hizmet tipi redüktörlerdir. Giriş ve çıkış milleri birbirine paralel veya dik olabilir. Her yönden bağlantı için ayak bağlantıları bulunur. Opsiyonel olarak flanş ile de bağlanabilir. Delik milli veya mil çıkışı olabilir.

##### - T Serisi

T Serisi redüktörler helisel dişli iki kademe motorsuz delik milli redüktörlerdir. T Serisi redüktörler delik milli olması ve kompakt gövde yapısı sayesinde daha küçük hacimli alanlara montajı yapılabilmektedir.

##### - P ve R Serisi

P ve R Serisi redüktörler planet dişli redüktörlerdir. Endüstriyel ve mobil uygulamalarda kullanılırlar. Diğer redüktör tiplerine göre daha küçük hacimde daha büyük tork iletebilirler.

##### - VR Serisi

VR vinç redüktörleri M1 - M8 (1Dm - 5m) yük sınıflarına uygun olarak, çift veya sabit devirli frenli motorlarla üretilebilmektedir.

#### Production Range

*This catalogue is containing E Series of gearboxes only.*

##### - M and N Series

*M and N series of YILMAZ REDÜKTÖR are helical geared. The input and output shafts are parallel to each other and on the same plane. The gearbox can be connected to the machine by using the foot or flange on the gearbox. Has solid output shaft.*

##### - D Series

*D series are helical geared gearboxes with parallel input and output shafts each other. The shafts have a distance in between and located on the same plane. The gearbox can be assembled to the machine by using the foot, the connection screws on the sides, flange or torque arm on the gearbox. Can have hollow or solid output shaft.*

##### - E Series

*E series gearboxes are with worm and worm-wheel. The input and output shafts are perpendicular to each other and have a distance in between. It can be assembled to the driven machine by the use of the foot, flange or torque arm on the gearbox. Can have hollow or solid output shaft.*

##### - Y Series

*Horizontal type gearboxes are designed to operate in heavy conditions. In these types there are a lot of combination forms between gearbox and driver (for example, mechanic and hydraulic couplings, various belt and chain drives etc.). Can have hollow or solid output shaft.*

##### - K Series

*These are gearboxes with helical and bevel gears. The input and output shafts are perpendicular to each other and have a distance in between. It can be assembled to the driven machine by using the foot, flange or torque arm on the gearbox. They have high efficiency compared to E series. Can have hollow or solid output shaft.*

##### - H and B Series

*These gearboxes are helical or/and bevel geared industrial gearboxes. The input and output shafts can be arranged parallel or perpendicular to each other. The gearbox can be assembled by the use of the foot connections on each side. Flange connections are optional. Can have hollow or solid output shaft.*

##### - T Series

*T Series are gear units which are helical geared, two staged, hollow shaft mounted gear units and manufactured according to monoblock principal. T Series gearboxes have hollow shaft and compact housing so that T series can be mounted on smaller places.*

##### - P and R Series

*P and R Series gearboxes are planetary gearboxes. They are mostly used by industrial and mobile applications. Planetary gearboxes can transfer high torques in small volumes compared to other gearboxes.*

##### - VR Serie

*VR hoist drives are produced according to M1 - M8 (1Dm - 5m) load classification.*

#### Produktpalette

Dieses Katalog umfasst nur die **E Serien** Getriebe.

##### - M und N Serie

Diese Modelle sind Stirnradgetriebe mit parallelen Antriebs- und Abtriebswelle auf einer Ebene. Die Getriebe werden mit Fuß- oder Flanschverbindung an die angetriebene Maschine angekoppelt. Hat Vollwelle am Ausgang.

##### - D Serie

Diese Getriebe sind Stirnradgetriebe mit paralleler Antriebs- und Abtriebswelle, die auf einer Ebene liegen und einen Abstand zueinander haben. Diese Getriebe wird seitlich mit Gewindelöchern am Maschine oder mit einer Flansch verbindet. Kann Voll- und Hohlwelle am Ausgang haben.

##### - E Serie

Diese Getriebe bestehen aus Schnecke und Schneckenrad. Die Antriebs- und Abtriebswellen sind senkrecht zueinander und haben einen bestimmten Abstand. Das Getriebe wird mit Fußbefestigung, Flanschverbindung oder mit Drehmomentstütze an die angetriebene Maschine montiert. Kann Voll- und Hohlwelle am Ausgang haben.

##### - Y Serie

Diese Getrieben sind für Einsatz unter schweren Bedingungen ausgelegt. Bei dieser Ausführung gibt es sehr viele verschiedene Verbindungsmöglichkeiten zwischen Antrieb und Getriebe (Zum Beispiel; mechanische und hydraulische Kupplungen, Riemtrieb, Kettentrieb usw.). Kann Voll- und Hohlwelle am Ausgang haben.

##### - K Serie

Diese Getrieben bestehen aus Stirnräder und Kegelhäder. Die Antrieb und Abtriebswellen sind senkrecht und haben einen Abstand zueinander. Das Getriebe wird mit Fußbefestigung, Flanschverbindung oder Drehmomentstütze an die angetriebene Maschine montiert. Der Wirkungsgrad ist wesentlich höher als E Serie. Kann Voll- und Hohlwelle am Ausgang haben.

##### - H und B Serie

Diese Getriebe sind geeignet für industrielle Anwendungen und haben parallelen oder senkrechten Antrieb und Abtriebswelle auf einer Ebene. Das Getriebe kann mit Füßen, die auf jede Seite der Getriebe vorhanden sind, oder optional mit Flansch an die angetriebene Maschine montiert werden. Kann Voll- und Hohlwelle am Ausgang haben.

##### - T Serie

TSerien Getriebe sind zwei stufige, schrägverzahnte Hohlwellenflachgetriebe in Monoblockgehäuse. Die T Serie hat eine kompakte Gehäuse und ist serienmäßig mit Abgangshohlwelle hergestellt, so dass das Getriebe minimalen Platzbedarf hat.

##### - P und R Serie

P und R Serie sind Planetengetriebe, die vielseitig im Industrie und bei mobiler Anwendungen einsetzbar sind, mit Planetenzahnräder. Planetengetriebe können im Vergleich zu anderen Getrieben größere Drehmomente bei kleineren Bauvolumen übertragen.

##### - VR Serie

VR Krane und Hebezeuge werden geeignet zur Belastungsart M1 - M8 (1Dm - 5m) hergestellt.



# Genel Bilgiler

## General Information

### Einführung



M ...

**13 farklı büyüklükte;**  
**Moment aralığı: 50 - 18.000 Nm**  
**Devir aralığı: 0,1 - 500 d/dak**  
13 different sizes:  
Torque range: 50 - 18.000 Nm  
Speed range: 0,1 - 500 rpm  
13 verschiedene Baugrößen:  
Drehmomentbereich: 50 - 18.000 Nm  
Drehzahlbereich : 0,1 - 500 U/min



N ...

**13 farklı büyüklükte;**  
**Moment aralığı: 50 - 18.000 Nm**  
**Devir aralığı: 0,1 - 500 d/dak**  
13 different sizes:  
Torque range: 50 - 18.000 Nm  
Speed range: 0,1 - 500 rpm  
13 verschiedene Baugrößen:  
Drehmomentbereich: 50 - 18.000 Nm  
Drehzahlbereich : 0,1 - 500 U/min

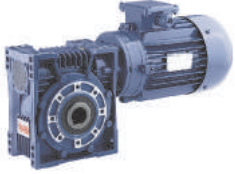

E ...

**8 farklı büyüklükte;**  
**Moment aralığı: 5 - 1.000 Nm**  
**Devir aralığı: 0,1 - 400 d/dak**  
8 different sizes:  
Torque range: 5 - 1.000 Nm  
Speed range: 0,1 - 400 rpm  
8 verschiedene Baugrößen:  
Drehmomentbereich: 5-1.000 Nm  
Drehzahlbereich : 0,1-400 U/min



K ...

**7 farklı büyüklükte;**  
**Moment aralığı: 200 - 15.000 Nm**  
**Devir aralığı: 0,1 - 400 d/dak**  
7 different sizes:  
Torque range: 200 - 15.000 Nm  
Speed range: 0,1 - 400 rpm  
7 verschiedene Baugrößen:  
Drehmomentbereich: 200 - 15.000 Nm  
Drehzahlbereich : 0,1 - 400 U/min



D...

**10 farklı büyüklükte;**  
**Moment aralığı: 130 - 18.000 Nm**  
**Devir aralığı: 0,1 - 350 d/dak**  
10 different sizes:  
Torque range: 130 - 18.000 Nm  
Speed range: 0,1 - 350 rpm  
10 verschiedene Baugrößen:  
Drehmomentbereich: 130 - 18.000 Nm  
Drehzahlbereich : 0,1 - 350 U/min



Y ...

**25 farklı büyüklükte;**  
**Moment aralığı: 1200 - 43000 Nm**  
**Devir aralığı: 2,6 - 990 d/dak**  
25 different sizes:  
Torque range: 1200 - 43000Nm  
Speed range: 2,6 - 990 rpm  
25 verschiedene Baugrößen:  
Drehmomentber. :1200-43000 Nm  
Drehzahlbereich : 2,6-990 U/min



H ...

**13 farklı büyüklükte;**  
**Moment aralığı: 2.500 - 150.000 Nm**  
**Devir aralığı: 0,1 - 250 d/dak**  
14 different sizes:  
Torque range: 2.500 - 150.000 Nm  
Speed range: 0,1 - 250 rpm  
14 verschiedene Baugrößen:  
Drehmomentber. :2.500 - 150.000 Nm  
Drehzahlbereich : 0,1 - 250 U/min

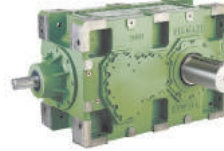

B ...

**13 farklı büyüklükte;**  
**Moment aralığı: 5.000 - 150.000 Nm**  
**Devir aralığı: 0,1 - 115 d/dak**  
13 different sizes:  
Torque range: 5.000 - 150.000 Nm  
Speed range: 0,1 - 115 rpm  
13 verschiedene Baugrößen:  
Drehmomentber. :5.000-150.000 Nm  
Drehzahlbereich : 0,1-115 U/min



P ...

**10 farklı büyüklükte;**  
**Moment aralığı: 1.000 - 50.000 Nm**  
**Tahvil oranları: 3,5 - 3000 arası**  
10 different sizes:  
Torque range: 1.000 - 50.000 Nm  
Transmission ratio: 3,5 - 3000  
10 verschiedene Baugrößen:  
Drehmomentber. : 1.000 - 50.000 Nm  
Übersetzung: 3,5 - 3000



R ...

**10 farklı büyüklükte;**  
**Moment aralığı: 1.000 - 50.000 Nm**  
**Tahvil oranları: 3,5 - 3000 arası**  
10 different sizes:  
Torque range: 1.000 - 50.000 Nm  
Transmission ratio: 3,5 - 3000  
10 verschiedene Baugrößen:  
Drehmomentber. : 1.000 - 50.000 Nm  
Übersetzung: 3,5 - 3000



T ...

**10 farklı büyüklükte;**  
**Moment aralığı: 200 - 18.000 Nm**  
**Devir aralığı: 46 - 280 d/dak**  
10 different sizes:  
Torque range: 200-18.000 Nm  
Speed range: 46-280 rpm  
10 verschiedene Baugrößen:  
Drehmomentber. :200-18.000 Nm  
Drehzahlbereich : 46-280 U/min

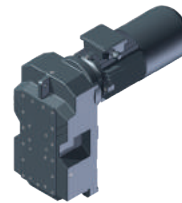

VR ...

**VR vinç redüktörleri**  
**M1 - M8 ,(1Dm - 5m) yük sınıfı**  
**ISO 4301 / 1 ,(FEM 1.001 / III)**  
VR Hoist Drive Units  
M1 - M8 ,(1Dm - 5m) load classification  
ISO 4301 / 1 ,(FEM 1.001 / III)  
VR Kran und Hebezeug Getriebe  
M1 - M8 ,(1Dm - 5m) Belastungsart  
ISO 4301 / 1 ,(FEM 1.001 / III)



## Genel Bilgiler General Information Einführung



### E Serisi Redüktörlerin Genel Özellikleri

E Serisi redüktörler, sonsuz vida ve dişli yapısında oluşan redüktörlerdir. Giriş ve çıkış milleri 90° olması gereken durumlarda kullanılır. Sertleştirilmiş ve taşlanmış vida (21NiCrMo2), fosfor bronzlu çark (Gz12SnCuNi) yüksek mukavemet ve verim sağlamaktadır.

E Serisi redüktörler her yandan bağlanabilen değişebilir gövde sistemi ile montaj kolaylığı ve esnekliği getirmektedir. Flanş ve çıkış mil bağlantıları çok alternatifli montajlar için uygundur.

E30-E80 Alüminyum enjeksiyon döküm, E100-E125 pik döküm gövde malzemesi kullanılmıştır.

YILMAZ REDÜKTÖR olarak tasarım prensibimiz;

- Yüksek teknoloji kullanmak
- Güvenilirlik,
- Yüksek güç yoğunluğu,
- Yüksek verim,
- Montaj uyumluluğu,
- Esnek çözümler

### Dikkat Edilecek Hususlar !

- Bu katalogta verilen resimler görsel amaçlıdır ve şekilsel detaylar bağlayıcı değildir.

- YILMAZ REDÜKTÖR, ürünler ve kataloglar üzerinde, müşterileri bilgilendirmeksizin her türlü değişikliği yapma hakkına sahiptir.

- Ürünler teslim alındıktan sonra ürünle birlikte verilen kullanım kılavuzu okunmadan sistem devreye alınmamalıdır.

- Katalogta verilen yağ miktarları referans amaçlıdır. Gerçek yağ seviyesi için redüktör üzerinde bulunan yağ seviye tapası kullanılmalıdır. Yağ viskozitesi için, redüktör etiketine bakınız.

- Sipariş anında montaj pozisyonu bildirilmeyen redüktörler **M1** montajına uygun sevk edilir. Etiketle yazan montaj pozisyonundan farklı bağlanan redüktörler garanti kapsamından çıkar. Bu katalogta verilen redüktör ağırlıkları ortalama ağırlık değerleridir. Tahvil oranına ve üzerinde bağlı olan aksesuara göre ağırlıklar farklılık gösterebilir.

### General Specifications of E Series Gearboxes

*E Series gearboxes are worm geared gearboxes. Input and output shafts are perpendicular to each other. Hardened and grounded cylindrical worm (21NiCrMo2) and phosphorus bronze worm wheel (Gz12SnCuNi) gives maximum strength and maximum efficiency.*

*With alternative mounting position from all sides provided easy and flexible assembly condition. Flange and output shaft connections are convenient for wide range of mounting.*

*From E030 to E080 gearbox housings are made of Aluminium injection casting, E100 and E125 sizes are made of iron casting housings.*

*As we are YILMAZ REDÜKTÖR, our design principals are;*

- Using high technology
- Reliability
- High power density
- High efficiency
- Mounting compatible
- Flexible solutions

### Attention to the following points !

*- Drawings are examples only and the details on the drawings or illustrations are not strictly binding.*

*- YILMAZ REDÜKTÖR reserve the right to make all kinds of changes in products and catalogues without any notice.*

*- Prior to commissioning, the operating instructions provided with the gearbox must be observed.*

*- Oil quantities given are guide values only. The exact quantity of oil should be checked by using the provided oil level plugs according mounting positions. For correct oil viscosity refer to the nameplate.*

*- If the mounting position is not informed upon ordering, the gear unit is delivered according to **M1** mounting position. If the mounting position is different than the indicated mounting position on the nameplate The product warranty cancels. The weights given in this catalogue are mean values. Depending on the ratio and accessories the weights can differ.*

### Allgemeine Eigenschaften von E Serie Getrieben

E Serie Getriebe sind Schneckenradgetriebe. Eingang- und Ausgangswelle sind senkrecht zueinander. Gehärtete und geschliffene Zylinderschnecke (21NiCrMo2) und Schneckenrad (Gz12SnCuNi) aus Bronze gibt maximale Stabilität und beste Effizienz.

Die verschiedene Möglichkeiten zur Befestigung von allen Seiten stellt einfache und flexible Montage zur Verfügung. Flansch und Anschlüsse von Abtriebswelle sind bequem für eine Vielzahl von Montage.

E30-E80 Baugrößen sind aus Aluminium mit Spritzgussverfahren gefertigt und E100-E125 Baugrößen haben aus Eisenguss gefertigte Gehäusen.

Als YILMAZ REDÜKTÖR unsere Entwurfsprinzipien sind;

- Verwenden von hohen Fertigungstechnik
- Hohe Betriebssicherheit
- Leistungsdichte
- Hoher Wirkungsgrad
- Universale Montagemöglichkeit
- Sonderlösungen

### Bitte folgende Punkte beachten !

- Die Abbildungen sind beispielhaft und nicht verbindlich.

- Alle-Änderungen auf dem Katalog und an der Produkte bleiben vorbehalten und können ohne Kenntnisnahme erfolgen.

- Vor Inbetriebnahme ist die mit gelieferter Betriebsanleitung zu beachten.

-Angaben über Ölmengen sind unverbindlich. Maßgebend ist die Ölstandsschraube in der geeigneten Montageposition. Ölviskosität und Sorte muss den Angaben des Typenschildes entsprechen.

- Wenn die Bauform bei der Bestellung nicht angegeben ist, erfolgt die Lieferung in der Bauform **M1**. Wenn die Getriebe anders als auf dem Typenschild benannte Bauform eingesetzt werden, verliert die Garantie ihre Gültigkeit. Die angegebenen Gewichte sind unverbindliche Mittelwerte ohne Zubehör; genauere Gewichte sind abhängig von Zubehör und Übersetzung.



# Genel Bilgiler

## General Information

### Einführung



#### Teknik Tanımlamalar

- **Çıkış Momenti  $M_2$ : [Nm]**  
Motorun verdiği momentin tahvil oranı ve verimle ile çarpılarak elde edilen değerdir. Redüktörün çıkışından alınabilecek moment gösterir.

- **Anma Momenti  $M_a$ : [Nm]**  
Redüktörün  $f_s=1$  şartı için mekanik olarak taşıdığı moment değeridir.

- **Nominal Güç  $P_e$ : [kW]**  
Nominal güç, redüktörün  $f_s=1$  şartı için mekanik olarak taşıyabileceği güç değeridir. Redüktörlerin nominal güçleri, güç devir tablolarında verilmiştir.

- **Çevrim oranı i:**  
Redüktörün giriş devrinin çıkış devrine oranıdır. Yılmaz Redüktör E serisi redüktörlerde 3,5-14000 arasında değişen çevrim oranları mevcuttur.

- **Eşdeğer Güç ve Moment  $P_{eq}$  [kW],  $T_e$  [Nm]**  
Sabit devir altında ancak değişken yük değerlerinde çalışan redüktörlerde, sabit yük altında çalışma şartlarına eşdeğer gelen moment ve güç değerleridir. Hesaplama yöntemi sayfa 28'de verilmiştir.

- **İhtiyaç güç  $P_M$ : [kW]**  
Redüktörlerin kullanılacağı uygulamanın istenilen şekilde çalışabilmesi için ihtiyaç duyduğu güç değeridir.

- **İhtiyaç moment T: [Nm]**  
Redüktörün kullanılacağı uygulamanın çalışabilmesi için ihtiyaç duyduğu moment değeridir. Seçilen redüktör için her zaman çıkış momentine eşit yada daha düşük olmalıdır.

- **Müsade Edilen Eksenel ve Radyal Yükler  $F_{qem}$ ,  $F_{qam}$ : [N]**  
Redüktörün giriş veya çıkış milinde müsade edilen eksenel ve radyal yüklerdir.

- **Servis Faktörü  $f_s$ :**  
Redüktörün çalıştığı şartlar ile uyumlu olması için gerekli olan emniyet katsayısıdır.  $f_s=1$ , düzgün ve sakin yüklerde, günlük sekiz saat, saatte 100 dur-kalk çalışmayı karşılar. Detaylar için redüktör seçim bölümüne bakınız.

#### Teknik Özellikler:

- **Ses seviyesi:**  
Redüktörlerimizin ses seviyesi VDI 2159' da verilen redüktörler için müsade edilen ses seviyelerinin altındadır.

- **Boya ve Korozyon Koruması:**  
Redüktörlerin standart rengi DIN1843'e göre RAL 5010 dur. İstek üzerine farklı renklerde boyanabilir. Nemli ve korozif bölgeler için istek üzerine farklı boya uygulanabilir.

#### Technical Explanations

- **Output Torque  $M_2$ : [Nm]**  
Multiplication of motor torque with transmission ratio and efficiency gives the result of output torque on the output shaft of the gear unit.

- **Nominal Torque  $M_a$ : [Nm]**  
Nominal torque is the mechanical torque which the gearbox can resist under  $f_s=1$  conditions.

- **Nominal Power  $P_e$ : [kW]**  
The nominal power is the power which gearbox can mechanically resist under  $f_s=1$  condition. The nominal powers are given on the performance tables.

- **Ratio i:**  
Ratio between output shaft speed and input shaft speed. Available ratios of Yılmaz Redüktör E series are between 3,5 to 14000.

- **Equivalent Power and Torque  $P_{eq}$ : [kW],  $T_e$  [Nm]**  
For gearbox value with constant speed but variable working conditions: This is the calculated power or torque which is equivalent to the values at working under constant working conditions. Calculation methods are given page on pages 28.

- **Required Power  $P_M$ : [kW]**  
Required power for the applications which is able to drive the system.

- **Required Torque T: [Nm]**  
Required torque for applications. Required torque always must be equal or smaller than output torque of selected gearbox.

- **Permissible Axial and Overhung Loads:  $F_{qem}$ ,  $F_{qam}$  [N]**  
Permissible axial and overhung load on the output or input shaft of gearboxes.

- **Service Factor  $f_s$ :**  
Service factor is a safety coefficient, which takes into account the different running conditions of the driven machine.  $f_s=1$  is used for uniform loads 8 hours working per day and up to 100 cycle per hour.

#### Technical Specifications:

- **Noise Level:**  
The noise level of our gearboxes is lower than permitted values defined in VDI guidelines 2159 for gear units.

- **Coating and Corrosion Protection:**  
The gearboxes are painted with RAL 5010 according DIN1843. Different colors are available upon request. Paintings for high humidity or chemically aggressive environments are available upon request.

#### Technische Erläuterungen

- **Ausgangsmoment  $M_2$ : [Nm]**  
Multiplikation von Ausgangsmoment des Motors mit Übersetzung und Division das Ergebnis mit Wirkungsgrad ergibt den Betrag von Ausgangsmoment der Getriebe.

- **Nennmoment  $M_a$ : [Nm]**  
Mechanisches Belastungsmoment der Getriebe unter dem Bedingung  $f_s=1$ .

- **Nennleistung  $P_e$ : [kW]**  
Die Nennleistung ist die mechanische Grenzfestigkeitsleistung für  $f_s=1$ . Kann von der Leistung- Drehzahltable abgelesen werden.

- **Übersetzung i:**  
Wird aus dem Verhältnis von Ausgang- zu Eingangswinkelgeschwindigkeit bestimmt. Gängige Übersetzungen von Yılmaz M Serie Getrieben liegt zwischen 3,5 bis 14000.

- **Äquivalente Leistung und Moment  $P_{eq}$ : [kW],  $T_e$  [Nm]**  
Für mit konstanten Drehzahl aber unter veränderlichen Betriebsbedingungen arbeitende Getriebe berechnete Leistung und Moment äquivalent zu Werten beim Arbeiten unter konstanten Betriebsbedingungen.

- **Notwendige Leistung  $P_M$ : [kW]**  
Für das Getriebe notwendige Leistung, um Arbeiten von Getriebe bei der für das Getriebe gedachten Anwendung zu gewährleisten.

- **Notwendige Moment T: [Nm]**  
Notwendige Moment für Anwendungen. Für den ausgewählte Getriebe soll das notwendige Moment gleich dem Ausgangsmoment oder kleiner als diesem Moment sein.

- **Zulässige Axial- oder Querkräfte:  $F_{qem}$ ,  $F_{qam}$  [N]**  
Bei der Anwendungen während der Betrieb zulässige axiale oder radiale Eingangs- oder Ausgangsbelastungen.

- **Betriebsfaktor  $f_s$ :**  
Dieser Faktor  $f_s$  ist ein Sicherheitsfaktor, damit die Getriebe unter verschiedenen Bedingungen mit genügender Sicherheit arbeitet.  $f_s=1$  gilt für gleichförmig Belastung, mit 8 Betriebsstunden pro Tag und bis zum 100 Schaltungen pro Stunde.

#### Technische Informationen:

- **Geräuschpegel:**  
Geräuschstärken aller Getriebe bleiben unter die zulässigen Werte, die für die Getriebe in der VDI-Richtlinie 2159 festgelegt sind.

- **Lackierung und Korrosionsschutz:**  
Die Getriebe werden mit der Farbe RAL 5010 nach DIN1843 lackiert. Auf Wunsch sind Sonderlackierungen möglich. Alle Getriebe können auf Wunsch auch in korrosionsgeschützter Ausführung für aggressive Umgebungen geliefert werden.



## Genel Bilgiler General Information Einführung



### - Yağlama:

E serisi redüktörler yağlama tablolarında verilen yağlar ile doldurulmaktadır. Yağ detayları için yağlama bölümüne bakınız.

### - Aksesuarlar:

E serisi redüktörlerde aşağıdaki aksesuarlar kullanılabilir

- IEC B5 Motor bağlantı flanşları
- Çıkış Bağlantı Flanşları
- Geri dönüş kilidi
- Özel keçe çözümleri,
- Şeffaf yağ seviye göstergesi
- Tork kolu
- Elektromanyetik frenler

Diğer özel aksesuarlar için lütfen, YILMAZ REDÜKTÖR ile temasa geçiniz.

### - Lubrication:

*E series of gearboxes are filled with oils which are indicated on lubrication tables. For lubrication details please refer to the lubrication section.*

### - Accessories:

*The following accessories can be applied to E series gearboxes.*

- IEC B5 Motor connection flange
- Output flanges
- Backstops
- Special sealing solutions.
- Transparent oil level indicator,
- Torque arm
- Electromagnetic brakes.

*For other accessories please contact, YILMAZ REDÜKTÖR.*

### - Schmierung:

E Serie Getriebe werden mit Ölen entsprechend der Schmierungstabellen, falls nicht anders vereinbart, geliefert. Für weitere Schmierungsangaben siehe Kapitel Schmierung.

### - Zubehör:

Folgendes Zubehör kann für Getriebe der E Serie geliefert werden.

- IEC B5 Motor Adapter,
- Abtriebsflansch,
- Rücklaufsperrn,
- Unterschiedliche Dichtungssysteme,
- Ölstandzeiger
- Drehmomentstütze
- Elektromagnetische Bremsen

Für weiteres Zubehör kontaktieren Sie bitte mit, YILMAZ REDÜKTÖR.



Genel Bilgiler  
General Information  
Einführung





# Genel Bilgiler General Information Einführung



Tip Tanımlaması / Unit Designation / Typenbezeichnung

## E V 063 . 01 - 90S/4 - L05

### Fren / Brake / Bremse

L-220V **Fanlı** / With Fan / Mit Lüfter  
P-24V **Fanlı** / With Fan / Mit Lüfter  
S-220 V **Fansız** / Without Fan / Ohne Lüfter  
Z-24 V **Fansız** / Without Fan / Ohne Lüfter

01-10 Nm      10-100Nm  
02-25 Nm  
04-40 Nm  
05-50 Nm

### Motor Büyüklüğü / Motor Size / Motorbaugröße

#### -EV Tipleri için / For EV types / Für Typen EV

90S / 4

└─ Kutup Sayısı / Pole Number / Anzahl der Polen  
└─ Gövde uzunluğu / Frame Length / Gehäuselänge des Motors  
└─ Motor büyüklüğü / Motor size / Motorbaugröße

#### -EN tipleri için / For EN Types / Für Typen EN

**A06** :63 B5      **A10** :100 B5  
**B06** :63 B14      **B10** :100 B14  
**A07** :71 B5      **A11** :112 B5  
**B07** :71 B14      **B11** :112 B14  
**A08** :80 B5      **A13** :132 B5  
**B08** :80 B14      **B13** :132 B14  
**A09** :90 B5  
**B09** :90 B14

### Çıkış Mili Özelliği / Output Shaft / Eigenschaften der Abtriebswelle

- 00** :Standart delik milli / Hollow Output Shaft / Standarte Ausführung mit Hohlwelle  
**01** :Mil Çıkışlı / Solid Output Shaft / Vollwelle  
**02** :Flanşlı ve mil çıkışlı / Solid Output Shaft and Output Flange / Mit Flansch und Abtriebsvollwelle  
**03** :Flanşlı ve delik milli çıkışlı / Output Shaft and Output Flange. / Mit Flansch und Hohltriebsschwelle  
**04** :Çift çıkış milli / With Double Output Shaft / Mit doppelte Abtriebswelle  
**05** :Çift flanşlı ve çift çıkış milli / With Double Flange and Double Output Shaft / Mit doppelte Flansch und doppelte Abtriebswelle  
**\*06** :Motor karşısından giriş mili çıkışlı / With Shaft Extension from the Motor Fan Cover Side / Mit doppelte verlängerte Abtriebswelle an der Motor  
**\*\*07** : Motorsuz çift giriş milli / With Double Input Shaft Without Motor / Mit doppelte Antriebswelle  
**08** : Çift flanşlı delik milli / With Double Output Shaft and Hollow Output Flange / Doppelte Flansch und Aufsteckenwelle

### Gövde Büyüklük / Housing Size / Größe von Gehäuse

030, 040, 050, 063, 075, 080,100, 125.

### Giriş Tipi / Input Type / Eingangstyp

**N** :Motorsuz ve IEC B5/B14 Flanş girişli / IEC B5 / B14 Input Flange without Motor / Ohne Motor und mit IEC B5/B14 Eingangsflansch  
**V** :Motorlu ve IEC B5/B14 Flanş girişli / IEC B5 / B14 Input Flange with Motor / Mit Motor und IEC B5/B14 Eingangsflansch  
**T** :Motorsuz / Without Motor Solid Input Shaft / Eingang mit Vollwelle ohne Motor

**\*EN ve EV tiplerinde giriş mili 06 opsiyonel olarak verilmektedir. Gösterim şekli EN050.01-06.A06 vb şeklindedir.**

\*06 code is optional input shaft option for EN and EV types. Description as EN050.01-06.A06.

\*Kode 06 ist auswählbare Eingangswelle für EN und EV Typen. Kann bei EN050.01-06.A06 angesehen werden.

### Redüktör Tipi / Gearbox Type / Getriebe

**E serisi / E serie / E Serie**

**\*\*ET tiplerinde giriş mili 07 opsiyonel olarak verilmektedir. Gösterim şekli ET050.00-07**

\*07 code is optional input shaft types for ET types. Description as ET050.00-07

\*Kode 07 ist auswählbare Eingangswelle für ET Typen. Kann bei ET050.00-07 angesehen werden.



# Genel Bilgiler

## General Information

### Einführung



#### Tip Tanımlaması / Unit Designation / Typenbezeichnung

EN..00..	<b>Sonsuz tip IEC B5/B14 bağlantılı redüktörler, delik milli çıkış / Worm geared units IEC B5/B14 input flange with hollow output shaft / Schneckenradgetriebe mit IEC B5/B14 Eingangsflansch und Hohlwelle am Ausgang</b>
EN..01..	<b>Sonsuz tip IEC B5/B14 bağlantılı redüktörler, mil çıkışlı / Worm geared units IEC B5/B14 input flange, with solid output shaft / Schneckenradgetriebe mit IEC B5/B14 Eingangsflansch und Vollwelle am Ausgang</b>
EN..02..	<b>Sonsuz tip IEC B5/B14 bağlantılı redüktörler, mil ve flanş çıkışlı / Worm geared units IEC B5/B14 input flange, with solid output shaft and output flange / Schneckenradgetriebe mit IEC B5/B14 Eingangsflansch, Vollwelle und Flansch am Ausgang</b>
EN..03..	<b>Sonsuz tip IEC B5/B14 bağlantılı redüktörler, delik milli ve flanş çıkışlı / Worm geared units IEC B5/B14 input flange, with hollow output shaft and output flange / Schneckenradgetriebe mit IEC B5/B14 Eingangsflansch, Hohlwelle und Flansch am Ausgang</b>
EN..04..	<b>Sonsuz tip IEC B5/B14 bağlantılı redüktörler, çift çıkış milli / Worm geared units IEC B5/B14 input flange, with double output shaft / Schneckenradgetriebe mit IEC B5/B14 Eingangsflansch und doppelter Abtriebswelle</b>
EN..05..	<b>Sonsuz tip IEC B5/B14 bağlantılı redüktörler, çift çıkış milli ve çift çıkış flanşlı / Worm geared units IEC B5/B14 input flange, with double output shaft and double output flange / Schneckenradgetriebe mit IEC B5/B14 Eingangsflansch, doppelter Abtriebswelle und doppelter Ausgangsflansch</b>
EN..08..	<b>Sonsuz tip IEC B5/B14 bağlantılı redüktörler, çift flanşlı delik milli / Worm geared units IEC B5/B14 input flange, with double output flange and hollow output shaft / Schneckenradgetriebe mit IEC B5/B14 Eingangsflansch, doppelter Ausgangsflansch und Hohlwelle am Ausgang</b>
EN.....06	<b>Sonsuz tip IEC B5/B14 bağlantılı redüktörler, motor karşısından giriş mili çıkışlı / Worm geared units IEC B5/B14 input flange, with shaft extension on the motor fan cover side / Schneckenradgetriebe mit IEC B5/B14 Eingangsflansch und Verlängerung von Motorwelle an der Seite des Deckels von Motorlüfter</b>

EV..00..	<b>Sonsuz tip motorlu redüktörler, delik milli çıkış / Worm geared motors IEC B5/B14 input flange with motor, hollow output shaft / Schneckenradgetriebemotor mit IEC B5/B14 Eingangsflansch und Hohlwelle am Ausgang</b>
EV..01..	<b>Sonsuz tip motorlu redüktörler, mil çıkışlı / Worm geared motors IEC B5/B14 input flange with motor, solid output shaft / Schneckenradgetriebemotor mit IEC B5/B14 Eingangsflansch und Vollwelle am Ausgang</b>
EV..02..	<b>Sonsuz tip motorlu redüktörler, mil ve flanş çıkışlı / Worm geared motors IEC B5/B14 input flange with motor, solid output shaft and output flange / Schneckenradgetriebemotor mit IEC B5/B14 Eingangsflansch, Vollwelle und Flansch am Ausgang</b>
EV..03..	<b>Sonsuz tip motorlu redüktörler, delik milli ve flanş çıkışlı / Worm geared motors IEC B5/B14 input flange with motor, hollow output shaft and output flange with motor / Schneckenradgetriebemotor mit IEC B5/B14 Eingangsflansch, Hohlwelle und Flansch am Ausgang</b>
EV..04..	<b>Sonsuz tip motorlu redüktörler, çift çıkış milli / Worm geared motors IEC B5/B14 input flange with motor, double output shaft with motor / Schneckenradgetriebemotor mit IEC B5/B14 Eingangsflansch und doppelter Abtriebswelle</b>
EV..05..	<b>Sonsuz tip motorlu redüktörler, çift çıkış milli ve çift çıkış flanşlı / Worm geared motors IEC B5/B14 input flange with motor, double output shaft and double output flange / Schneckenradgetriebemotor mit IEC B5/B14 Eingangsflansch, doppelter Abtriebswelle und doppelter Ausgangsflansch</b>
EV..08..	<b>Sonsuz tip motorlu redüktörler, çift flanşlı delik milli / Worm geared motors IEC B5/B14 input flange with motor, double output flange and hollow output shaft / Schneckenradgetriebemotor mit IEC B5/B14 Eingangsflansch, doppelter Ausgangsflansch und Hohlwelle am Ausgang</b>
EV....-06	<b>Sonsuz tip motorlu redüktörler, motor karşısından giriş mili çıkışlı / Worm geared motors IEC B5/B14 input flange with motor, shaft extension on the motor fan cover side / Schneckenradgetriebemotor mit IEC B5/B14 Eingangsflansch und Verlängerung von Motorwelle an der Seite des Deckels von Motorlüfter</b>

ET..00..	<b>Sonsuz tip motorsuz redüktörler, delik milli çıkış / Worm geared units solid input shaft, hollow output shaft / Schneckenradgetriebe mit Vollwelle am Eingang und Hohlwelle am Ausgang</b>
ET..01..	<b>Sonsuz tip motorsuz redüktörler, mil çıkışlı / Worm geared units solid input shaft, solid output shaft / Schneckenradgetriebe mit Vollwelle am Eingang und Vollwelle am Ausgang</b>
ET..02..	<b>Sonsuz tip motorsuz redüktörler, mil ve flanş çıkışlı / Worm geared units solid input shaft, solid output shaft and output flange / Schneckenradgetriebe mit Vollwelle am Eingang, Vollwelle und Flansch am Ausgang</b>
ET..03..	<b>Sonsuz tip motorsuz redüktörler, delik milli ve flanş çıkışlı / Worm geared units solid input shaft, hollow output shaft and output flange / Schneckenradgetriebe mit Vollwelle am Eingang, Hohlwelle und Flansch am Ausgang</b>
ET..04..	<b>Sonsuz tip motorsuz redüktörler, çift çıkış milli / Worm geared units solid input shaft, double output shaft / Schneckenradgetriebe mit Vollwelle am Eingang und doppelter Abtriebswelle</b>
ET..05..	<b>Sonsuz tip motorsuz redüktörler, çift çıkış milli ve çift çıkış flanşlı / Worm geared units solid input shaft, double output shaft and double output flange / Schneckenradgetriebe mit Vollwelle am Eingang, doppelter Abtriebswelle und doppelter Ausgangsflansch</b>
ET..08..	<b>Sonsuz tip motorsuz redüktörler, çift flanşlı ve delik mil çıkışlı / Worm geared units solid input shaft, double flange and hollow output shaft / Schneckenradgetriebe mit Vollwelle am Eingang, doppelter Ausgangsflansch und Hohlwelle am Ausgang</b>
ET....-07	<b>Sonsuz tip motorsuz redüktörler, motorsuz çift giriş milli / Worm geared units solid input shaft, double input shaft / Schneckenradgetriebe mit Vollwelle am Eingang und Verlängerung von Motorwelle an der Seite des Deckels von Motorlüfter</b>



# Genel Bilgiler

## General Information

### Einführung

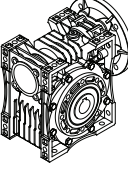
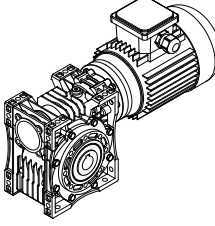
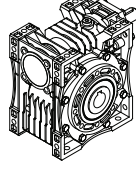
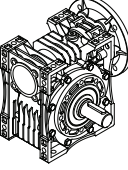
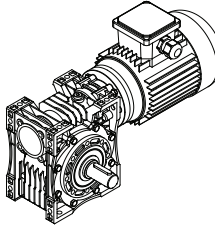
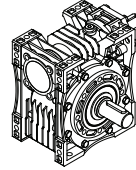
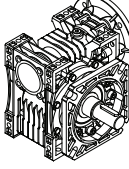
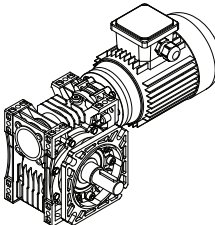
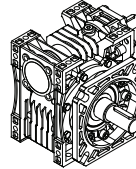
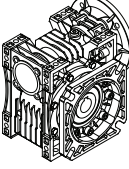
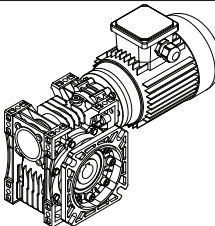
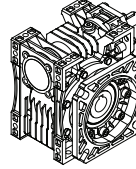
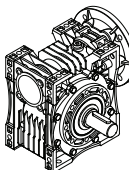
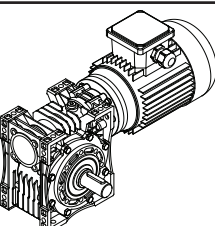
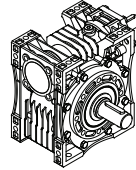
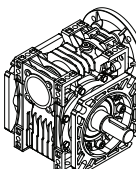
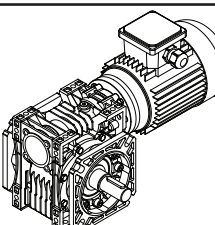
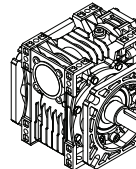
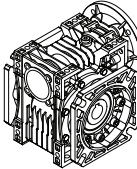
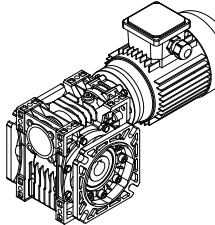
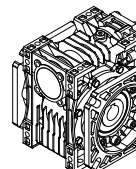

Tip Tanımlaması / Unit Designation / Typenbezeichnungen

 EN...00	 EV...00	 ET...00
 EN...01	 EV...01	 ET...01
 EN...02	 EV...02	 ET...02
 EN...03	 EV...03	 ET...03
 EN...04	 EV...04	 ET...04
 EN...05	 EV...05	 ET...05
 EN...08	 EV...08	 ET...08



# Genel Bilgiler

## General Information

### Einführung

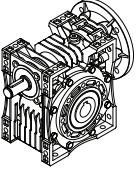
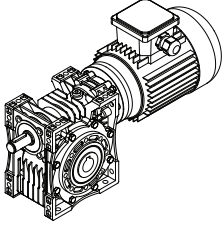
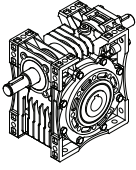
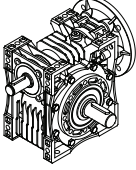
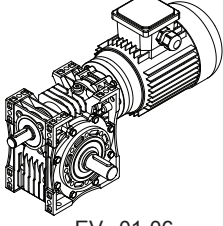
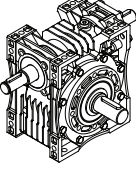
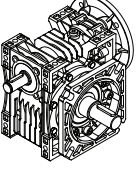
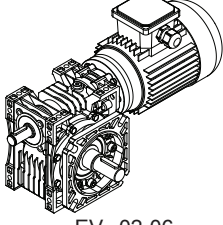
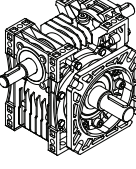
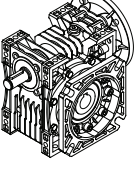
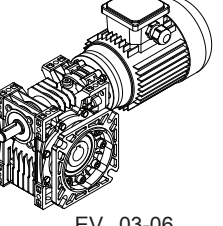
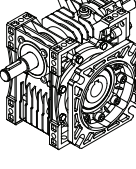
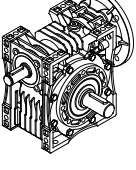
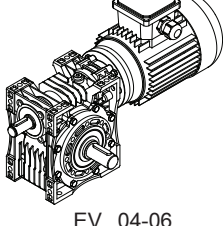
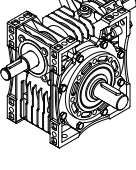
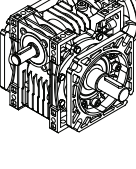
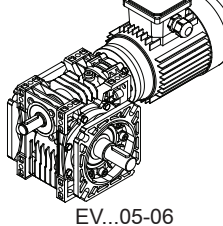
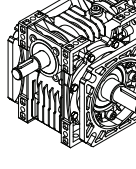
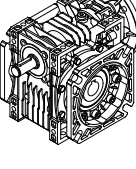
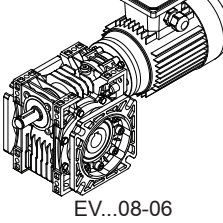
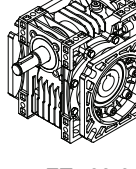

Tip Tanımlaması / Unit Designation / Typenbezeichnungen

 EN...00-06	 EV...00-06	 ET...00-07
 EN...01-06	 EV...01-06	 ET...01-07
 EN...02-06	 EV...02-06	 ET...02-07
 EN...03-06	 EV...03-06	 ET...03-07
 EN...04-06	 EV...04-06	 ET...04-07
 EN...05-06	 EV...05-06	 ET...05-07
 EN...08-06	 EV...08-06	 ET...08-07



# Genel Bilgiler

## General Information

### Einführung



#### Örnek Tip Tanımlamaları

EV063.00.90S/4

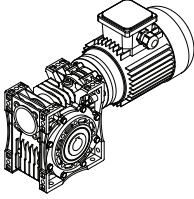

E.....: E serisi redüktör  
V.....: IEC B5/B14 Motor bağlantılı  
063.....: Gövde büyüklüğü  
00.....: Delik mil çıkışı  
90S/4.....: Motor büyüklüğü  
L02.....: Fren Tipi

ET075.01

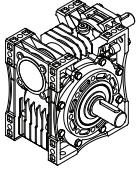

E.....: E serisi redüktör  
T.....: Motorsuz giriş millî  
075.....: Gövde büyüklüğü  
01.....: Mil çıkışı  
EN075.03 - A11

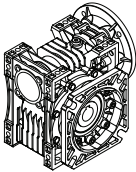

E.....: E serisi redüktör  
N.....: Motorsuz ve IEC B5/B14 giriş flanşlı  
075.....: Gövde büyüklüğü  
03.....: Delik millî flanş bağlantılı çıkış  
A11.....: 112 tip motor, B5/B14 bağlantı flanş

EV100.01-100L/4

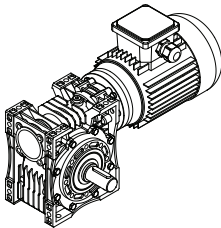

E.....: E serisi redüktör  
V.....: Motorlu ve IEC B5/B14 giriş flanşlı  
100.....: Gövde büyüklüğü  
01.....: Mil çıkışı  
100L/4.....: Motor büyüklüğü ve kutup sayısı

#### Sample Designations

EV063.00.90S/4

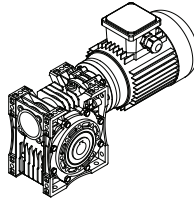

E.....: E series gearbox  
V.....: IEC B5/B14 Motor Connection  
063.....: Gear Unit Size  
00.....: Hollow Shaft Output  
90S/4.....: Motor Size  
L02.....: Brake Type

ET075.01

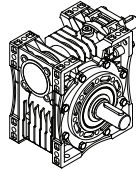

E.....: E series gearbox  
T.....: Solid input shaft  
075.....: Gear unit size  
01.....: Solid output shaft  
EN075.03 - A11

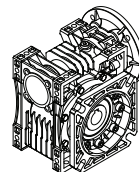

E.....: E series of gearbox  
N.....: IEC B5/B14 flange without motor input  
075.....: Gear unit size  
03.....: Hollow output shaft and output flange  
A11.....: IEC 112 B5/B14 motor connection flange.

EV100.01-100L/4

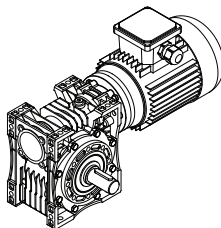

E.....: E series of gearbox  
V.....: IEC B5/B14 flange with motor  
100.....: Gear unit size  
01.....: Solid shaft Output  
100L/4.....: Motor size and number of poles

#### Typenbezeichnungsbeispiele

EV063.00.90S/4

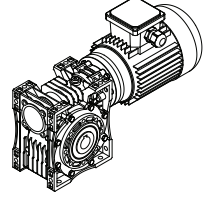

E.....: E serie Getriebe  
V.....: Mit Motor und IEC B5/B14 Eingangs  
flanş  
063.....: Größe von Gehäuse  
00.....: Ausführung mit Hohlwelle  
90S/4.....: Motorbaugröße  
L02.....: Bremse

ET075.01

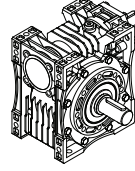

E.....: E serie Getriebe  
T.....: Vollwelleneingang ohne Motor  
075.....: Größe von Gehäuse  
01.....: Vollwelle  
EN075.03 - A11

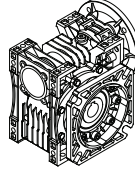

E.....: E serie Getriebe  
N.....: Ohne Motor und mit IEC B5/B14  
Eingangsflanş  
075.....: Größe von Gehäuse  
03.....: Mit Flanş und Hohltriebsschwelle  
A11.....: Motor typ 112, B5 Motorflanş

EV100.01-100L/4

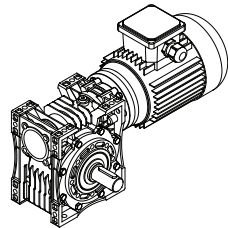

E.....: E serie Getriebe  
V.....: Mit Motor und IEC B5/B14 Flanş  
100.....: Größe von Gehäuse  
01.....: Vollwelle  
100L/4.....: Motorbaugröße und Anzahl der Pole



# Genel Bilgiler

## General Information

### Einführung

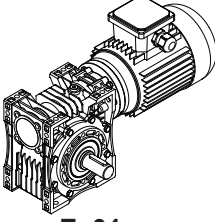
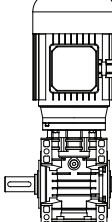
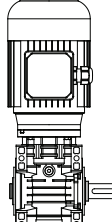
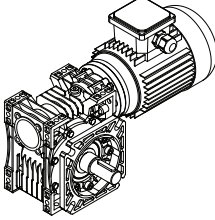
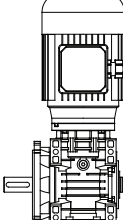
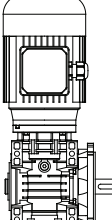
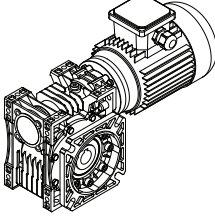
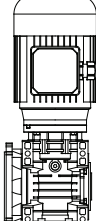
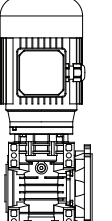

Redüktör Çıkış Özelliği / Gearbox Output Shaft and Flange Arrangement / Eigenschaft der Ausgang

Redüktör Çıkış Özelliği Gearbox Output Specification Eigenschaft der Ausgang	R	L
 E..01		
 E..02		
 E..03		

### Klemens Pozisyonları

Aşağıda gösterildiği gibi klemens kutuları farklı açısız pozisyonlarda olabilir (A,B,C). Doğru pozisyon için ilgili ölçü sayfasını dikkate alınız.

### Terminal Box Positions

Terminal Boxes can be at different angular positions (A,B,C) as shown below. Please take in to account related gearbox dimension pages for right position.

### Klemmenkastenpositionen

Klemmenkasten können unterschiedliche Stellungen nehmen, siehe unten. (A,B,C) Bitte beachten Sie die Abmessungsseiten für die richtige Position.

A

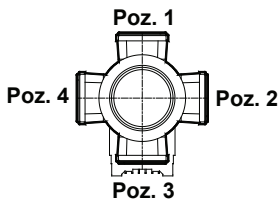

B

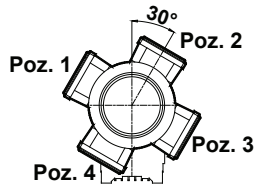

C

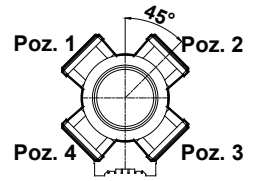

### Klemens Kablo Çıkış Pozisyonları

Kablo çıkış pozisyonları motor üstünden bakarak sağ veya sol olarak aşağıdaki gibi seçilebilir.

### Terminal Box Cable Output Positions

Terminal box cable output positions can be selected as right side or left side according to top view of terminal box.

### Kabelaşang von der Klemmenkasten

Kabelaşangseite von der Klemmenkasten kann als links oder rechts gemäß Blickrichtung oben von dem Motor ausgewählt werden.

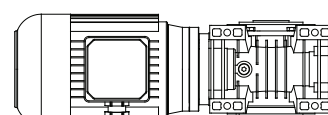
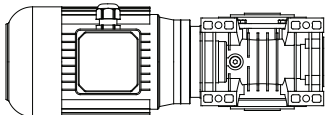

A tipi kablo çıkışı / B type Cable Output / Kabelaşang A

B tipi Kablo Çıkışı / B type Cable output / Kabelaşang B



# Genel Bilgiler

## General Information

### Einführung



#### Moment kolu Pozisyonları

Moment kolu pozisyonları aşağıdaki gibidir.

#### Torque Arm Positions

Torque arm positions are shown on below.

#### Stelle Von Drehmomentstütze

Drehmomentstützestellungen wurden unten dargestellt.

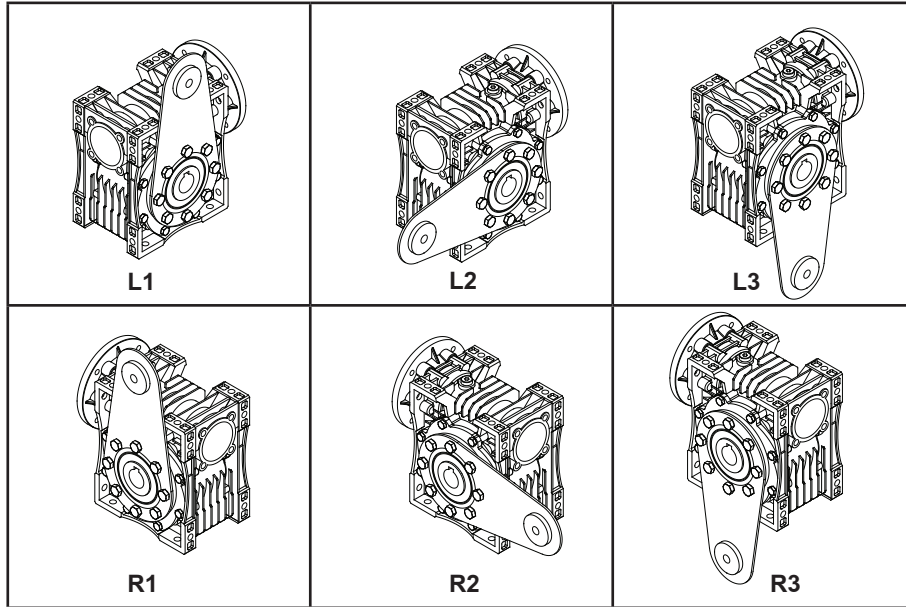
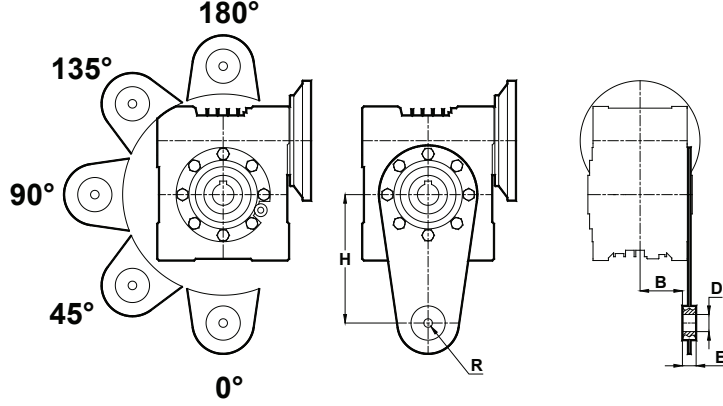

Tipi Type Typ	b	e	d	h	R	Parça No. Part No. Teil Nr.
EX030	22	14	10	85	25	9E030
EX040	31	14	10	100	25	9E040
EX050	38	16	10	100	32	9E050
EX063	49,5	16	10	150	36	9E063
EX075	46,5	25	20	200	45	9E075
EX080	49,5	25	20	200	45	9E080
EX100	57,5	30	25	250	50	9E100
EX125	72	30	25	300	55	9E125



# Genel Bilgiler

## General Information

### Einführung



#### Redüktör Dönüş Yönleri

Giriş mili dönüş yönüne göre çıkış mili dönüş yönleri aşağıdaki gibidir.

#### Direction of Rotation

Output shaft rotation directions according to the input shaft rotation directions are as follows.

#### Getriebedrehrichtungen

Drehrichtungen der Abtriebswelle im Abhängigkeit von der Antriebswellen sind wie folgendes;

Tip / Type / Typ	Saat Yönde / Clockwise / Rechtslauf CW	Saat Tersi Yönde / Counter Clockwise / Linkslauf CCW
ET...01		
ET...NT..		
ET...01-ET...		



# Genel Bilgiler

## General Information

### Einführung



#### Motor Büyüklüğüne Göre Geometrik Mümkün Çevrim Oranları

Geometrically Possible Combinations of Ratios According to Motor Size  
Geometrisch mögliche Kombinationen von Übersetzungen nach Motorbaugröße

#### Motor Büyüklüğü / Motor Size / Motorbaugröße

Tip Type Typ	Kademe Stages Stufen	56	63	71	80	90	100	112	132
E..030..	W	5,25-80	5,25-80	-	-	-	-	-	-
E..040..	W		8-100	8-100	-	-	-	-	-
E..040-030..	W+W	84-3720	84-3720	-	-	-	-	-	-
E..050..	W	-	19-100	7,25-100	7,25-100	7,25-100	-	-	-
E..050-L01..	W+H	-	87-498	87-498	87-498	87-498	-	-	-
E..050-030..	W+W	138-4980	138-4980	-	-	-	-	-	-
E..063..	W	-	-	7,25-100	7,25-100	7,25-100	-	-	-
E..063-L01..	W+H	-	117-600	117-600	117-600	117-600	-	-	-
E..063-030..	W+W	210,25-4920	210,25-4920	-	-	-	-	-	-
E..075..	W	-	-	-	7,5-100	7,5-100	7,5-100	7,5-100	-
E..075-L11..	W+H	-	-	111,75-745	111,75-745	111,75-745	-	-	-
E..075-040..	W+W	-	-	60-6200	60-6200	-	-	-	-
E..080..	W	-	-	-	7,5-110	7,5-110	7,5-110	7,5-110	-
E..080-L11..	W+H	-	-	111,75-819,5	111,75-819,5	111,75-819,5	-	-	-
E..080-040..	W+W	-	180-5084	180-5084	-	-	-	-	-
E..100..	W	-	-	-	7,5-107	7,5-107	7,25-107	7,25-107	-
E..100-L11	W+H	-	-	149-797,15	149-797,15	149-797,15	-	-	-
E..100-050..	W+W	-	180-5084	180-5084	180-5084	180-5084	-	-	-
E..125..	W	-	-	-	-	7,25-107	7,25-107	7,25-107	7,25-62
E..125-L21..	W+H	-	-	125,58-516,81	125,58-516,81	125,58-516,81	125,58-516,81	125,58-516,81	-
E..125-063	W+W	-	184,88-5084	184,88-5084	184,88-5084	184,88-5084	-	-	-



# Genel Bilgiler

## General Information

### Einführung



#### Servis Faktörü

Servis faktörü (fs) redüktörün çalıştığı şartlar ile uyumlu olması için gerekli olan emniyet katsayısıdır. "fs =1" Düzgün ve sakin yüklerde, günlük sekiz saat ve saatte yüz start çalışmayı karşılar.

Aşağıdaki etkenlere bağlıdır:

- Günlük çalışma süresi
- Yük sınıfı
- Bir saatteki start sayısı
- Redüktör tahrik tipi
- Diğer gözlemler

Bu etkenleri göz önüne aldığımızda, gerekli servis faktörünü belirlemek için:

1. Makinanın günlük çalışma süresini tespit ediniz.
2. Makinanın ne türde yükler verdiğini tespit ediniz (Sayfa 17-18 ).

- U - Düzgün ve sabit yükler
- M - Orta darbeli yükler
- H - Ağır darbeli yükler

Yük sınıfının daha teknik seçimi için rotora indirgenmiş toplam atalet momenti formülünden faydalanabilirsiniz (Sayfa 20).

3. Saatteki start sayısını tespit ediniz.
4. İlk üç maddeye bağlı servis faktörünü aşağıdaki tablodan seçiniz.

5. fs Redüktörümüzün tahrik tipine bağlı olarak "k" katsayısı ile çarpılarak artırılır.

- k=1 :Elektrik motoru veya hidromotor  
k=1.25 :İçten yanmalı çok silindirli motor  
k=1.5 :İçten yanmalı tek silindirli motor

#### Service Factor

Service Factor (fs) is a safety coefficient, which takes into account the different running conditions of the driven machine. "fs=1" is used for uniform loads 8 hours working per day and up to 100 starts per hour.

Service factor depends on:

- Running time
- Nature of load
- Frequency of starting
- Driver type
- Other considerations

For the right selection of the needed service factor for your machine;

1. Determine the running time of driven machine.
2. Select the nature of load of driven machine (Page 17-18).

- U - Uniform loads
- M - Moderate loads
- H - Heavy shock loads

For a better selection, the nature of load can be calculated from the formulas given (page 20).

3. Determine frequency of starting.
4. After determining the above mentioned factors, the service factor can be easily selected from the table given below.
5. The selected service factor multiplied with the factor "k" according to the driver type;

- k=1 :Electric motor or Hydraulic motor  
k=1.25 :Multicylinder internal combustion engine  
k=1.5 :Single cylinder internal combustion engine

#### Betriebsfaktor

Der Betriebsfaktor (fs) ist ein Sicherheitsfaktor für die Getriebe, damit sie unter den Betriebsbedingungen sicher arbeiten. "fs =1" steht für gleichförmige Belastung, 8 Stunden pro Tag und bis zu 100 Schaltungen pro Stunde.

Betriebsfaktor ist abhängig von:

- Betriebsdauer
- Belastungsart
- Schalthäufigkeit
- Antriebsart
- Andere Faktoren

Um die richtigen Betriebsfaktor festzulegen;

1. Betriebsdauer der angetriebenen Maschine bestimmen.
2. Belastungsart der angetriebenen Maschine auswählen.

- U - Gleichförmige Belastung
- M - Ungleichförmige Belastung
- H - Stark ungleichförmige Belastung

Um eine bessere Auswahl zu treffen, können die Belastungsarten mit den angegebenen Formeln (Seite 20) errechnet werden.

3. Schalthäufigkeit bestimmen.
4. Nach Bestimmen der oben angegebenen Werte, können die Betriebsfaktoren von der unten stehenden Tabelle entnommen werden.
5. Der ausgewählte Betriebsfaktor muß mit dem Faktor "k" abhängig von der Antriebsart multipliziert werden

- k=1 :Elektromotor oder Hydraulikmotor  
k=1.25 :Vielzylindermotor  
k=1.5 :Einzylindermotor

Günlük Çalışma Süresi  
Operating Time hour / Day  
Laufzeit Std. / Tag

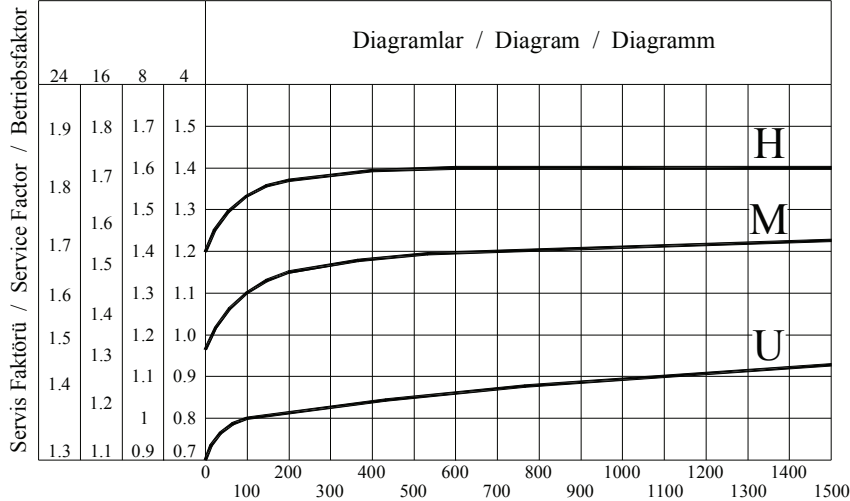

Start sayısı / Saat  
Cycle / Hour  
Schaltungen / Std.



# Genel Bilgiler

## General Information

### Einführung



#### Yük Sınıflandırması

##### Krenler:

- U - Kaldırma Dişlileri
- Palanga Dişlileri
- M - Bomlu Vinç Dişlileri
- Yana Döndürme Dişlileri
- H - Yürütme Dişlileri

##### Pompalar:

- U - Santrifuj Pompalar (ince sıvı)
- M - Santrifuj Pompalar (yarı sıvı)
- H - Basıncılı Pompalar
- Dalgıç Pompalar

##### Taş ve Kil İşleme Makinaları:

- H - Çekiçli Değirmenler
- Döner Fırınlr
- Dövücü Değirmenler
- Kırıcılar
- Küreli Değirmenler
- Tuğla Presi
- Tüp Değirmenler

##### Tekstil Makinaları:

- M - Basma ve Boyama Makinaları
- Dokuma Tezgahları
- Hallac Makinaları
- Harman Makinaları
- Taneleme (Debegat )Tekneleri

##### Yağ Sanayi:

- M - Besleme Pompaları
- Döner Delme Teçhizatları

##### Yiyecek Sanayi:

- M - Kutu Bıçaklar
- Kutu Kaplama
- Mayalama Tekneleri
- H - Kenar Açma

##### Çamaşır Yıkama Makinaları:

- M - Döner Kurutucular
- Yıkama Makinaları

##### Hadde Makinaları:

- M - Hız Ayarlı Silindirler
- Sabit Silindirler
- Sarma Makaraları
- Tel Çekme
- H - Çubuk Kesme Makinaları
- Döner Tablalar (büyük)
- Kabuk Sıyırma Makinaları
- Plaka Haddeleme
- Silindir Haddeleme
- Soğuk Haddeleme

#### Load Classification

##### Cranes:

- U - Hoist Gears
- Lifting Gears
- M - Defrocking jib Gears
- Slowing Gears
- H - Travelling Gears

##### Pumps:

- U - Centrifugal Pumps (light liquids)
- M - Centrifugal Pumps (semi liquid)
- H - Pressure Pumps
- Plunger Pumps

##### Stone and Clay Working Machines:

- H - Hammer Mills
- Rotary Kilns
- Beater Mills
- Breakers
- Ball Mills
- Brick Presses
- Tüp Mills

##### Textile Machines:

- M - Printing and Dyeing Machines
- Looms
- Willow
- Batcher
- Tanning Vats

##### Oil Industry:

- M - Pipeline Pumps
- Rotary Drilling Equipment

##### Food Industry:

- M - Cane Knives
- Cane Crushers
- Mach Tubs
- H - Cane Mills

##### Laundries:

- M - Tumblers
- Washing Machines

##### Metal Rolling Mills:

- M - Roller Adjustment Drives
- Roller Straightened
- Winding Machines
- Wire Drawing Benches
- H - Billet Shears
- Rotary Tables (heavy)
- Descaling Machines,
- Sheet Mills
- Manipulators
- Cold Rolling Mills

#### Belastungsart

##### Krananlagen:

- U - Einziehwerke
- Hubwerke
- M - Schwenkwerke
- Wippwerke
- H - Fahrwerke

##### Pumpen:

- U - Kreiselpumpen (leichte Flüssigkeit)
- M - Kreiselpumpen (zahe Flüssigkeit)
- H - Prebpumpen
- Plungerpumpen

##### Stein- und Erdebearbeitende Maschine

- H - Hammermühlen
- Drehofen
- Schlagmühlen
- Brecher
- Kugelmühlen
- Ziegelpressen
- Rohrmühlen

##### Textilmaschinen:

- M - Drukerei
- Farbereimachinen
- Aufwickler
- Webstuhle
- Gerbfasser
- Reibwolfe

##### Erdölgewinnung:

- M - Pipeline Pumpen
- Rotative Bohranlagen

##### Nahrungsmittelmachinen:

- M - Rohrschneiden
- Knetmaschinen
- Maichen
- H - Rohrmühlen

##### Waschereimaschinen:

- M - Trommeltrockner
- Waschmaschinen

##### Wälzwerke:

- M - Rollenrichtmaschinen
- Walzenantriebe
- Drahtzuge
- Haspeln
- H - Blechscheren
- Rollgänge (schwer)
- Knüppelscheren
- Schöpfscheren
- Stranggubanlagen
- Kaltwälzwerke



# Genel Bilgiler

## General Information

### Einführung



#### İnşaat Makinaları:

- M - Beton Mikserleri  
- Ağır Yük Asansörleri

#### Kağıt Makinaları:

- H - Islak Presler  
- Kağıt Hamur Makinaları  
- Kurutma Silindirleri  
- Perdahlama Silindirleri

#### Kauçuk Makinaları:

- M - Kalenderler  
- Mikserler  
H - Extruderler  
- Hamur Karma  
- Silindirler

#### Kimya Sanayi:

- M - Agidatörler (yarı sıvı)  
- Kurutma Merdaneleri  
- Mikserler ve Silindirleri

#### Konveyörler:

- M - Bant Ceppli Konveyörler  
- Çelik Bantlı Konveyörler  
- Dökme Yüklü Kayışlı Konv.  
H - Yük Asansörleri  
- Parça Yüklü Kayışlı Konv.

#### Building Machines:

- M - Concrete Mixers  
- Hoist

#### Paper Machines:

- H - Wet Presses  
- Pulpers  
- Drying Cylinders  
- Glazing Cylinders

#### Rubber Machinery:

- M - Calenders  
- Mixers  
H - Extruders  
- Pug Mills  
- Rolling Mills

#### Chemical Ind.:

- M - Aggidators (semi- liquid)  
- Drying Drums.  
- Mixers and Rolling Mills

#### Conveyors:

- M - Band Pocket Conveyors  
- Steel Belt Conveyors  
- Belt Conveyors  
H - Hoists  
- Bulk Belt Conveyors

#### Baumaschinen:

- M - Betonmischermaschinen  
- Bauaufzüge

#### Papiermaschinen:

- H - Naßpressen  
- Gautschen  
- Trockenzylinder  
- Glattzylinder

#### Kunststoffmaschinen:

- M - Kalender  
- Mischer  
H - Extruder  
- Knetwerke  
- Wälzwerke

#### Chemische Industrie:

- M - Rührwerke (leichte Flüssig.)  
- Trockentrommeln  
- Mischer und Wälzwerke

#### Förderanlagen:

- M - Gurtaschenbecherwerke  
- Stahlbandförderer  
- Gurtbandförderer (Schüttgut)  
H - Schrägaufzüge  
- Gurtbandförderer (Stückgut)

U	<b>Uniform Yük</b> Uniform Loads Gleichförmige Last	$F_i < 0,25$
M	<b>Orta Darbeli Yük</b> Moderate Loads Ungleichförmige Last	$F_i < 3$
H	<b>Darbeli Yük</b> Heavy Shock Loads Stark Ungleichförmige Last	$F_i < 10$

$$J'_{ext} = \frac{J_{ext}}{i^2}$$

$$F_i = \frac{J'_{ext}}{J_{rotor}}$$

$J'_{ext}$  : **Motor miline indirgenmiş toplam dış atalet momenti**  
External moments of inertia reduced to the motor shaft  
Externe massenträgheitsmomente reduziert auf motorwelle

$i$  : **Tahvil oranı**  
Transmission ratio  
Übersetzung

$J_{rotor}$  : **Motorun atalet momenti**  
Moments of inertia to the motor  
Massenträgheitsmoment



# Genel Bilgiler

## General Information

### Einführung



### Radyal Yükler

Çıkış miline gelebilecek radyal ve eksenel yükler yatak ömrüne göre belirlenmiş ve tablolar halinde verilmiştir. Bu tablolarda verilen  $F_{qam}$  güvenilir radyal yükü emniyet katsayısı 1 için ve yükün mil ortasını yüklediği durum için verilmiştir. Darbeli yüklerin olması ( $f_s=1$ ) durumunda izin verilen radyal yük değerleri servis faktörü kadar azaltılmalıdır. Verilen radyal ve eksenel yükler kuvvetin en kötü açı şartında etki ettiği durum için verilmiştir. Mil ucuna gelen kuvvetin açısına göre daha yüksek radyal yükler mümkündür (Firmamıza danışınız). Bağlantı şekline göre oluşan radyal yük  $F_q$  sayfa 23 de verilen formüller yardımı ile hesaplanır.

Redüktör seçiminde ;

$$\begin{aligned} F_{qa} &\leq F_{qam} \\ F_{qe} &\leq F_{qem} \end{aligned}$$

şartı göz önünde tutulmalı. Eğer etkiyen radyal kuvvet milin orta noktasında değil ise verilen güvenilir değer in aşağıda verilen formül ile düzeltilmesi gerekir.

$$F_{qam}' = F_{qam} \cdot \frac{t}{y + u}$$

$$F_{qem}' = F_{qem} \cdot \frac{t}{y + u}$$

"t", "y" Değerleri aşağıda verilmiştir. "u" Değeri görüldüğü gibi kuvvetin uygulama noktasıdır.

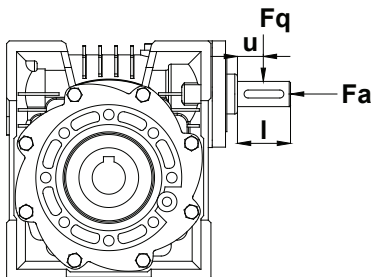
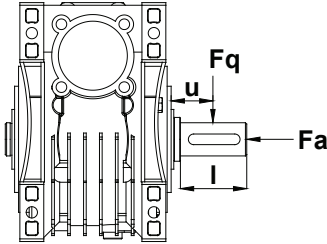

### Overhung Loads

The permissible overhung loads are calculated by considering working life and is listed on the tables. The given permissible overhung loads  $F_{qam}$  are based on safety factor 1 and are valid for forces which are applied to the midpoint of the shaft.

For shock loading ( $f_s = 1$ ) permissible radial loads must be divided with service factor. The listed permissible overhung loads are based on the worst loading direction. Higher overhung loads can be applied for different loading directions (Please ask if requested). The effective overhung load at the gearbox shaft  $F_q$  will be determined with the given formulas on page 23.

In Selection ;

$$\begin{aligned} F_{qa} &\leq F_{qam} \\ F_{qe} &\leq F_{qem} \end{aligned}$$

these formulas must be taken into consideration. If the load is not applied at the midpoint of the shaft; the given permissible load must be corrected with the following formulas.

$$F_{qam}' = F_{qam} \cdot \frac{t}{y + u}$$

$$F_{qem}' = F_{qem} \cdot \frac{t}{y + u}$$

The values "t", "y" can be taken from the below table. The value "u" is the length of the application point as shown below.

### Querkräfte

Die in den nachfolgenden Tabellen angegebenen zulässigen Radialbelastungen  $F_{qam}$  gelten bei Kraftangriff auf die Mitte Wellenendes. Den Angaben liegt der Sicherheitsfaktor gleich 1 zu Grunde. Bei stoßartigen Belastungsfällen ist auch hier der entsprechende Betriebsfaktor ( $f_s=1$ ) zu berücksichtigen. Zulässige Axialkräfte  $F_{ama}$  oder  $F_{ame}$  wurden für den Fall mit schlechter Belastungsrichtung angegeben. Bei der Ermittlung der zulässige Querkräfte sind höhere Werte möglich (Bitte Rückfragen). Die auftretende Querkraft  $F_q$  ab der Getriebewelle wird wie in der nachfolgenden Formel bestimmt.

Bei dieser Auswahl;

$$\begin{aligned} F_{qa} &\leq F_{qam} \\ F_{qe} &\leq F_{qem} \end{aligned}$$

müssen die oben angegebenen Bedingungen berücksichtigt werden. Ist der Kraftangriff nicht auf Wellenmitte, so kann die zulässige Querkraft mit Hilfe der unten stehenden Formel auf jede beliebige Stelle umgerechnet werden.

$$F_{qam}' = F_{qam} \cdot \frac{t}{y + u}$$

$$F_{qem}' = F_{qem} \cdot \frac{t}{y + u}$$

Die Werte "t" und "y" sind in den nachfolgenden Tabellen angegeben. Der Wert "u" ist die Stelle des Kraftangriffs wie auf der nächsten Seite angegeben.

### Çıkış mili radyal kuvvet hesabı düzeltme katsayıları

Overhung Load correcting values on output shaft  
Korrigierungszahlen für Querkraft auf Ausgangswelle

Tip Type Typ	E.030	E.040	E.050	E.063	E..075	E.080	E.100	E.125
t	67	86	107	131	138,5	163	185	210
y	53	66	82	106	106	123	135	155
l	30	40	50	50	65	65	80	100

### Giriş mili Radyal kuvvet hesabı düzeltme katsayıları

Overhung load correcting values on input shaft  
Korrigierungszahlen für Querkraft auf Eingangswelle

Tip Type Typ	ET030	ET040	ET050	ET063	ET075	ET080	ET100	ET125
t	85	118	144	172,5	195	207	247	310
y	75	103	129	152,5	170	182	217	278
l	20	30	40	40	50	50	60	65



# Genel Bilgiler

## General Information

### Einführung

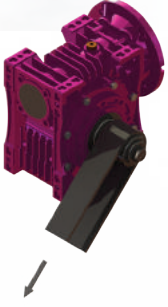

#### Radyal Yüklerin Hesabı

Radyal Yük  $F_q$  [N]'nin hesaplanması da, gerekli tahrik momenti  $M$  [Nm], kasnak veya dişli çapı  $D$  [mm] olmak üzere aşağıdaki formüller kullanılır.



#### 1. Elastik Kaplin

Çalışma sırasında oluşan sapsmalar kaplinin güvenlik sınırları içinde ise kuvvetler ihmal edilebilir.



#### 2. Düz Dişli (20° kavrama açısı)

$$F_q = \frac{2100 \times M_2}{D}$$



#### 3. Küçük Hızlarda Zincir Dişli ( $z > 17$ )

$$F_q = \frac{2100 \times M_2}{D}$$



#### 4. Triger Kayış

$$F_q = \frac{2500 \times M_2}{D}$$



#### 5. V Kayış

$$F_q = \frac{5000 \times M_2}{D}$$



#### 6. Gerdirme Makaralı Kayış

$$F_q = \frac{5000 \times M_2}{D}$$

#### Calc. Of Overhung Loads

Overhung Load  $F_q$  [N] is calculated with the following equations where required moment  $M$  [Nm] and hoop or gear diameter  $D$  [mm] is used.

#### 1. Elastic Coupling

If Elastic Coupling is working in its reliable working area, the overhung loads can be neglected.

#### 2. For Spur Gear (Pressure angle 20°)

$$F_q = \frac{2100 \times M_2}{D}$$

#### 3. For Chain Drive With Low Speed ( $z > 17$ )

$$F_q = \frac{2100 \times M_2}{D}$$

#### 4. For Triger Belt

$$F_q = \frac{2500 \times M_2}{D}$$

#### 5. For V Belt

$$F_q = \frac{5000 \times M_2}{D}$$

#### 6. Flat Belt With Spanning Pulley

$$F_q = \frac{5000 \times M_2}{D}$$

#### Berechnung der Querkräfte

Der Fall der radialen Belastung  $F_q$  [N] kann mit den angegebenen Gleichungen berechnet werden. Antriebsmoment  $M$  [Nm] und Zahnrad- oder Riemenscheiben Durchmesser  $D$  [mm].

#### 1. Elastische Kupplung

Wenn die elastische Kupplung in ihrem zulässigen Arbeitsbereich arbeitet, können die radialen Belastungen vernachlässigt werden.

#### 2. Stirnradgetriebe (Angriffswinkel 20°)

$$F_q = \frac{2100 \times M_2}{D}$$

#### 3. Kettenantrieb mit niedriger Geschwindigkeit ( $z > 17$ )

$$F_q = \frac{2100 \times M_2}{D}$$

#### 4. Zahnriemenantrieb

$$F_q = \frac{2500 \times M_2}{D}$$

#### 5. Keilriemenantrieb

$$F_q = \frac{5000 \times M_2}{D}$$

#### 6. Flachriemenantrieb mit Spannungstrommel

$$F_q = \frac{5000 \times M_2}{D}$$



# Genel Bilgiler

## General Information

### Einführung



#### Sonsuz Vidalarda Termik Güç

Güç-devir tablolarında verilen nominal termik güç  $P_t$  değerleri, 70°C yağ sıcaklığını aşmayacak şekilde 20°C maksimum çevre sıcaklığında sürekli çalışma durumu için, redüktör girişine uygulanabilir maksimum güç değeridir. Gerçek termik güç  $P_{tg}$  değeri, yukarıda bahsedilen  $P_t$  değerinden yüksek olabilir.

$$P_{tg} = P_t \times k_t$$

Burada  $k_t$  değeri çevre sıcaklığı ve yüklem durumuna bağlı termik faktördür. Aşağıdaki tablodan  $k_t$  seçilebilir.

Redüktöre uygulanan giriş gücü  $P_g$  değeri verilen  $P_{tg}$  değerinden daha düşük olmalıdır. ( $P_g < P_{tg} = P_t \times k_t$ ). Eğer  $P_g > P_{tg}$  ise özel imkanlar araştırılmalıdır (bize danışınız).

Termik güç değeri sürekli çalışma süresi 1 - 3 saati geçmiyorsa ve bu sürekli çalışmadan sonra redüktör çevre sıcaklığına düşene kadar çalışmıyorsa ihmal edilebilir. (yaklaşık 1 - 3 saat).

#### Thermal Power for Worm Gearboxes

Nominal thermal power  $P_t$ , indicated in our catalogue in performance tables can be applied at the gear reducer input when operating in continuous duty at a maximum ambient temperature of 20° C without exceeding 70° C oil temperature. Thermal power  $P_{tg}$ , can be higher than the nominal  $P_t$ , described above, as per the following formula,

$$P_{tg} = P_t \times k_t$$

where  $k_t$  is the thermal factor depending on ambient temperature and type of duty as indicated in the table below.

Applied power  $P_g$ , should be less than or equal to the  $P_{tg}$  value ( $P_g < P_{tg} = P_t \cdot k_t$ ). If  $P_g > P_{tg}$ , explore the possibilities and consult us.

Thermal power need not be taken into account when maximum duration of continuous running time is 1 - 3 h followed by shutdown periods long enough to restore the gear reducer to near ambient temperature (approx. 1 - 3 h).

#### Thermische Leistung für Schneckenradgetriebe

Die Werte in den Leistung - Drehzahl Tabellen geben die Nennwärmeleistung  $P_t$  an. Unter dieser Größe versteht man diejenige Leistung, die bei Dauerbetrieb und max. Umgebungstemperatur von 20°C an die Antriebswelle des Getriebes angelegt werden kann, ohne Getriebeöltemperatur 70°C zu überschreiten. Die Wärmeleistung  $P_{tg}$  kann höher liegen als die beschriebene Nennwärmeleistung  $P_t$ . Es gilt die Formel

$$P_{tg} = P_t \times k_t$$

wobei  $k_t$  der Wärmefaktor ist, dessen Werte im Verhältnis zur Umgebungstemperatur und Betriebsart stehen und von der Tafel entnommen werden können.

Die  $P_g$  Werte müssen überprüft werden, ob die Leistung  $P_g$  kleiner oder gleich der Wärmeleistung  $P_{tg}$  ist ( $P_g < P_{tg} = P_t \cdot k_t$ ). Bei  $P_g > P_{tg}$  eventuelle Verwendungen bitte rückfragen.

Die Wärmeleistung braucht nicht berücksichtigt zu werden, wenn der Dauerbetrieb höchstens 1 - 3 Stunden währt und sich daran genügend lange Ruhezeiten (ca. 1 - 3 Stunden) anschließen, damit im Getriebe wieder ca. die Umgebungstemperatur herrscht.

Maksimum Çevre Sıcaklığı [°C] Maximum Ambient Temperature [°C] Maximale Umgebungstemperatur [°C]	Çalışma Türü için $k_t$ / $k_t$ for Operation Type / $k_t$ für Betriebsarten				
	Sürekli (S1)	Duraksamalı çalışma şekli (S3...S6) 60 dakikada çalışma yüzdesi			
	Continuously (S1)	Duty on intermittent load (S3...S6) Intermittence ratio for 60 minutes running			
	Dauerhaft (S1)	Betrieb bei unterbrochener Belastung (S3...S6) Verhältnis in Prozent bei 60 Minuten intermittierendem Betrieb			
	-	%60	%40	%25	%15
40	0,8	0,9	1	1,2	1,3
30	0,9	1,1	1,2	1,4	1,5
20	1	1,2	1,4	1,5	1,7
10	1,2	1,4	1,5	1,7	1,9



# Genel Bilgiler

## General Information

### Einführung



#### Verim

Redüktörlerde verim  $\eta = P_{N2} / P_{N1}$  oranından elde edilir. Bu değer redüktörün normal şartlarda çalıştığı, iyi yağlama yapıldığı ve yükün nominal değere yakın olduğu taktirde geçerlidir. Sonsuz Vidalı redüktörlerde ilk 50 saatlik çalışma süresi içinde verim sonsuz vida tablolarında verilen değerlerden aşağıdaki yüzdeler kadar (ağız sayılarına bağlı olarak) daha düşük olacaktır;

z1= 1 ; %12  
z1= 2 ; %6  
z1= 3 ; %3

Statik verim  $\eta_s$  start anında oluşan verimdir ve dinamik verim  $\eta'$  nin çok altındadır. Motor nominal devrine ulaştığında redüktörün verimi katalogta verilen değerlere ulaşacaktır. Helisel dişli tiplerde katalogta verim değeri verilmemiştir.

Helisel dişli tiplerin (monoblok, delik milli ve yatık) verimleri kademe başına 0,98 civarındadır.

İnvers verim  $\eta_{inv}$  çıkış mili tarafından redüktöre tahrik gelmesi ile oluşan verimdir ve her zaman  $\eta'$  dan küçüktür. Bu değer aşağıdaki gibi hesaplanır.

$$\eta_{inv} = 2 - \frac{1}{\eta}$$

Benzer şekilde statik invers verim:

$$\eta_{Sinv} = 2 - \frac{1}{\eta_s}$$

#### Efficiency

Efficiency is derived from the  $\eta = P_{N2} / P_{N1}$  ratio. The value obtained will be valid assuming normal working conditions, correct lubrication and a load near the nominal value. In worm gearboxes, during the initial working period (about 50 hours) efficiency will be less than the catalogue values (according worm start number) referred to the values below ;

z1=1 ; 12%.  
z1=2 ; 6%.  
z1=3 ; 3%

Static efficiency  $\eta_s$  is the efficiency on starting, and is less than  $\eta$ ; as speed picks up gradually, efficiency will rise correspondingly until the catalogue value is reached. On the helical gearboxes the efficiency is not given on the performance tables.

In these types (Monoblock, Hollow Shaft and Horizontal type gearboxes) the efficiency is about 0,98 for each stage.

Inverse efficiency  $\eta_{inv}$  that produced by the worm wheel as drive is always less than  $\eta$ . It can be calculated approximately as follow:

$$\eta_{inv} = 2 - \frac{1}{\eta}$$

Likewise Static inverse efficiency;

$$\eta_{Sinv} = 2 - \frac{1}{\eta_s}$$

#### Wirkungsgrad

Wirkungsgrad ergibt sich aus dem Verhältnis  $\eta = P_{N2} / P_{N1}$ . Die damit berechneten Werte beziehen sich auf normale Betriebsbedingungen, einwandfreie Schmierung und dem Nennwert ungefähr gleicher Belastung. Bei Schneckengetrieben der Wirkungsgrad erweist sich in den ersten Betriebsstunden (ca. 50 Std.) etwas niedriger. Es ist abhängig von Zähnezahl wie unten angegeben.

z1= 1 ; 12%  
z1= 2 ; 6%  
z1= 3 ; 3%

Der statische Wirkungsgrad  $\eta_s$  beim Anlauf liegt weit unter den Tabellenwerten; mit Anstieg der Drehzahl erhöht sich der Wirkungsgrad bis auf die Tabellenwerte. Bei Stirnradgetrieben ist Wirkungsgrad nicht angegeben. Für Stirnradgetrieben (Monoblok, Flachgetriebe und Horizontal type getrieben) Wirkungsgrad ist ungefähr 0,98 für jede Stufe.

Den umgekehrten Wirkungsgrad  $\eta_{inv}$  hat man, wenn der Antrieb vom Schneckenrad erteilt wird. Er ist stets kleiner und kann annäherungsweise durch die Formeln ausgedrückt werden.

$$\eta_{inv} = 2 - \frac{1}{\eta}$$

Statische umgekehrten Wirkungsgrad;

$$\eta_{Sinv} = 2 - \frac{1}{\eta_s}$$



# Genel Bilgiler

## General Information

### Einführung



#### Sonsuz Vidada Otoblokajlık:

##### A ) Dinamik Otoblokaj

Dinamik otoblokajlı bir sonsuz vida redüktörünün tahrik tarafında motor momenti ile sonsuz vida, pervane, kaplin gibi bağlantı elemanlarının atalet momentleri ortadan kalktıktan sonra vidanın ani olarak kilitlemesi olayıdır. Dinamik otoblokaj  $\eta < 0,5$  olduğunda gerçekleşir. Fren yardımı olmadan yükü durdurmak ve tutmak istendiğinde gerekli olur. Sürekli vibrasyonlu durumlarda dinamik otoblokaj elde edilemeyebilir.

##### B ) Statik Otoblokaj

Statik otoblokaj çıkış mili tarafından hiç bir hareketin iletilmediği durumda olan otoblokaj'dır.

Statik otoblokaj  $\eta_s < 0.5$  aralığı içindedir. Fakat verimin zaman içinde yükselebileceği göz önünde tutularak  $\eta_s \leq 0.4$  ( $\gamma_m < 5^\circ 30'$ ) olarak kabul edilmesi tavsiye edilir. Sürekli vibrasyonlu durumlarda statik otoblokajlık elde edilemeyebilir.

Eğer  $\eta_s$  statik verimi  $0.5 \leq \eta_s < 0.55$  ( $7^\circ < \gamma_m \leq 11^\circ$ ) aralığında olursa düşük statik geri dönebilirlik (çıkış şaftı tarafına vibrasyon ve/veya yüksek moment uygulandığında döndürmek mümkün) oluşur.

Eğer  $\eta_s \geq 0.55$  ( $\gamma_m \geq 11^\circ$ ) olursa tam statik geri dönebilirlik (çıkış şaftı tarafından döndürmek mümkün) oluşur. Bu durum çıkış mili tarafından gelen yükleri otoblokaj etmesi gerekmeyen yumuşak kalkışlı durumlar için geçerlidir.

#### Irreversibility by Wormgears:

##### A ) Dynamic Irreversibility

*Dynamic irreversibility is a self blocking event on the driving side, directly after the moment of inertia of driving motor and moment of the driving side elements (like coupling, rotor shaft, cooling fan etc.) settles down to zero. There is dynamic irreversibility if  $\eta < 0,5$ . This state becomes necessary wherever there is a need for stopping and holding the load, even without the aid of a brake. Where continuous vibration occurs, dynamic irreversibility may not be obtainable.*

##### B ) Static Irreversibility

*A gear unit or geared motor is statically irreversible (that is, rotation cannot be imparted by way of the low speed shaft) when  $\eta_s < 0.5$ . This is a state necessary to keeping the load standstill; taking into account, however, that efficiency can increase with time spent in operation, it would be advisable to assume  $\eta_s \leq 0.4$  ( $\gamma_m < 5^\circ 30'$ ). Where continuous vibration occurs, static irreversibility may not be obtainable.*

*A gear reducer or geared motor has low static reversibility (i.e. rotation may be imparted by way of the low speed shaft with high torque and / or vibration) when  $0.5 < \eta_s < 0.55$  ( $7^\circ < \gamma_m < 11^\circ$ ).*

*A gear reducer or geared motor has complete static reversibility (i.e. rotation may be imparted by way of the low speed shaft) when  $\eta_s \geq 0.55$  ( $\gamma_m \geq 11^\circ$ ). This state is advisable where there is a need for easy startup of the gear reducer by way of the low speed shaft.*

#### Schneckengetriebe Selbsthemmung:

##### A ) Dynamische Selbsthemmung

Schneckengetriebe oder Getriebemotoren sind dynamisch selbsthemmend wenn  $\eta < 0,5$  ist. Sofortiges Einwirkung der Selbsthemmung, sobald die Drehung der Schneckenwelle aufhört und Motormoment Trägheit der Schnecke, Schwungräder, Kupplungen und des Lüfters, Motors usw. überwindet. Diese Bedingung benötigt man in allen Fällen, wo man eine Last ohne Bremsvorrichtung stoppen und halten will. Bei ständig auftretenden Vibrationen lässt sich die dynamische Selbsthemmung nur schwer verwirklichen.

##### B ) Stillstand Selbsthemmung

Schneckengetriebe oder -getriebemotoren sind im Stillstand selbsthemmend, wenn  $\eta_s < 0.5$  ist (Drehung von langsam laufender Welle aus nicht möglich). Diese Bedingung benötigt man in allen Fällen, wo man eine Last halten will. Da der Wirkungsgrad sich im Laufe des Betriebs erhöhen kann, sollte  $\eta_s \leq 0.4$  ( $\gamma_m < 5^\circ 30'$ ) am besten eingehalten werden. Bei ständig auftretenden Vibrationen lässt sich die Selbsthemmung im Stillstand nur schwer verwirklichen. Schneckengetrieben sind im Stillstand kaum selbsthemmend (Drehung von langsam laufender Welle aus nur mittels hoher Drehmomente und / oder durch das Auftreten von Vibrationen möglich) wenn  $0.5 < \eta_s < 0.55$  ( $7^\circ < \gamma_m < 11^\circ$ ) ist.

Schneckengetrieben sind statisch vollkommen selbsthemmend (Drehung von langsam laufender Welle aus möglich), wenn  $\eta_s \geq 0.55$  ( $\gamma_m \geq 11^\circ$ ) ist. Diese Bedingung ist ratsam, wo das Getriebe leichtgängig über die langsam laufende Welle angetrieben werden muss.



# Genel Bilgiler

## General Information

### Einführung



#### Eşdeğer Güç Hesabı

Sabit devirde, ancak değişken momentlerde (güçlerde) çalışan redüktörler için eşdeğer tork altındaki, eşdeğer güç hesaplanabilir. Bu eşdeğer güç kullanılarak bilinen sabit güçteki redüktör seçim yöntemi kullanılarak seçim yapılabilir. Burada ağırlıklı torka göre eşdeğer anma torku belirlenmektedir. Hesaplanan bu güçte çalışan redüktör, teorik olarak, değişken yüklerde çalışan redüktör ile aynı emniyet değerine ve ömre sahiptir.

Bir çevrim boyunca oluşan değişken torklar, en yüksek torktan, en düşüğe doğru yatay zaman eksenini boyunca sıralanır (bakınız alttaki şekil). Bu şekile göre eşdeğer tork şu formül ile hesaplanır;

$$T_e = \left( \frac{\Delta t_1 \times T_1^{6.6} + \dots + \Delta t_n \times T_n^{6.6}}{t} \right)^{\frac{1}{6.6}}$$

Eğer  $T_n$  değerleri (en düşük tork),  $T_e$ 'nin 0,5 katının altında ise, bu tork dilimi yok sayılarak, işlem tekrarlanır;

Eğer  $T_n < T_e \times 0.5$  ise

$$T_e = \left( \frac{\Delta t_1 \times T_1^{6.6} + \dots + \Delta t_{n-1} \times T_{n-1}^{6.6}}{t - \Delta t_n} \right)^{\frac{1}{6.6}}$$

Tüm  $T_n$  değerleri  $T_e$ 'nin 0,5 katının üzerinde ise, eşdeğer güç aşağıdaki gibi hesaplanır;

$$P_{eq} = P_N = \frac{T_e \times n}{9550}$$

Eşdeğer gücün bulunmasından sonra eşdeğer güç değeri kullanılarak, bu katalogta verilen redüktör seçimi bölümünde anlatılan adımlar uygulanarak redüktör seçimi tamamlanır.

#### Equivalent Power Rating Calculation

The equivalent power by an equivalent constant torque can be calculated for gearboxes working in constant speed but variable torques (or powers). Using this equivalent power it is possible to make a gearbox selection according to the usual gearbox selection method with constant torques. The equivalent torque will be determined according to the mean of dominating torques. The gearbox working in constant equivalent torque will theoretically have the same lifetime and safety compared to the variable torque one.

To calculate the equivalent torques, the variable torques in a cycle must be sorted from the maximal to the minimal on a horizontal time line (Check the graphic below). According to the graphic below the equivalent torque can be calculated with the following formula;

$$T_e = \left( \frac{\Delta t_1 \times T_1^{6.6} + \dots + \Delta t_n \times T_n^{6.6}}{t} \right)^{\frac{1}{6.6}}$$

If  $T_n$  (the lowest torque) is lower than 50 % of  $T_e$ , this torque part must be taken out of the torque graph and the calculation must be repeated;

If  $T_n < T_e \times 0.5$  then

$$T_e = \left( \frac{\Delta t_1 \times T_1^{6.6} + \dots + \Delta t_{n-1} \times T_{n-1}^{6.6}}{t - \Delta t_n} \right)^{\frac{1}{6.6}}$$

If all  $T_n$  values are higher than 50% of  $T_e$  then the equivalent power can be calculated by the following formula;

$$P_{eq} = P_N = \frac{T_e \times n}{9550}$$

After the equivalent power is determined the selection of gearbox is made according to the selection procedures given on the gearbox selection part in this catalogue.

#### Berechnung Äquivalenter Leistung

Die äquivalente Leistung bei äquivalenten Drehmoment kann für Getrieben mit konstanten Drehzahl und variablen Momente berechnet werden. Mit dieser Leistung kann das Getriebe ausgelegt werden, wie bei konstanten Leistung. Man bestimmt hiermit also die maßgebende Belastung. Das ausgelegte Getriebe erreicht theoretisch dem gleichen Lebensdauer und hat die gleiche Sicherheit.

Für die Berechnung der äquivalenten Drehmoment müssen die einzelnen Drehmomentanteile auf eine Zeitachse von größten bis zu kleinsten angeordnet werden (siehe unteres Bild). Das äquivalente Drehmoment wird nach folgender Formel berechnet;

$$T_e = \left( \frac{\Delta t_1 \times T_1^{6.6} + \dots + \Delta t_n \times T_n^{6.6}}{t} \right)^{\frac{1}{6.6}}$$

Wenn  $T_n$  (niedrigstes Drehmoment) kleiner als 50% von  $T_e$  ist, muss dieser Anteil vernachlässigt werden und die Berechnung soll neu durchgeführt werden;

Wenn  $T_n < T_e \times 0.5$  dann

$$T_e = \left( \frac{\Delta t_1 \times T_1^{6.6} + \dots + \Delta t_{n-1} \times T_{n-1}^{6.6}}{t - \Delta t_n} \right)^{\frac{1}{6.6}}$$

Wenn alle  $T_n$  Werte höher als 50% von  $T_e$  sind, dann wird die äquivalente Leistung nach folgender Formel berechnet;

$$P_{eq} = P_N = \frac{T_e \times n}{9550}$$

Nach Bestimmung der äquivalenter Leistung, erfolgt die Getriebeauslegung wie bei konstanter Leistung. Die Auswahlverfahren für konstante Leistung ist in diesem Katalog angegeben.

(Moment / Torque / Moment)

T [Nm]

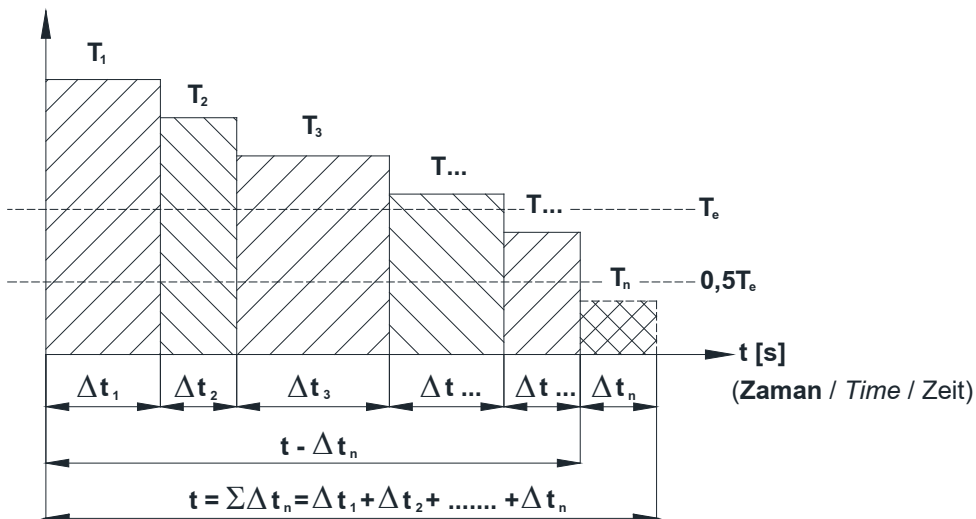



# Genel Bilgiler

## General Information

### Einführung



#### Eşdeğer Güç Hesabı Örneği

Çift yönlü çalışan ham demir haddesi için aşağıdaki çalışma koşulları belirlenmiş;

##### Veriler:

Toplam bir iş çevrimi: 2 dak.

1. Yük kademesi: 48 kNm, 30 s
2. Yük Kademesi: 32 kNm, 22 s
3. Yük Kademesi: 28 kNm, 15 s
4. Yük Kademesi: 16 kNm, 10 s
5. Yük Kademesi: 5 kNm, 43 s

Makina sabit devri: 50 d/dak

Redüktör seçimine esas olacak eşdeğer yük aranmaktadır.

##### Çözüm:

Bir çevrimin toplam zamanı;

$$t = t_1 + t_2 + t_3 + t_4 + t_5 = 120 \text{ sn}$$

Eşdeğer Tork;

$$T_e = \left( \frac{30 \times 48^{6.6} + \dots + 43 \times 5^{6.6}}{120} \right)^{\frac{1}{6.6}}$$
$$= 39,2 \text{ kNm}$$

%50 eşdeğer tork;

$$0.5 \times T_e = 19.6 \text{ kNm}$$

Her bir tork dilimi bu değer üzerinde olmalı

$$T_4, T_5 < 0.5 \times T_e$$

%50 torkun altındakileri çıkararak hesabı tekrarlayalım;

$$t' = t - t_4 - t_5 = 120 - 43 - 10 = 67 \text{ s}$$

$$T_e = \left( \frac{30 \times 48^{6.6} + \dots + 15 \times 28^{6.6}}{67} \right)^{\frac{1}{6.6}}$$
$$= 42,9 \text{ kNm}$$

Moment ve devir değerlerini kullanarak eşdeğer gücümüzü hesaplayalım ;

$$P_{eq} = \frac{T_e \times n}{9550} = \frac{42,9 \times 1000 \times 50}{9550} \cong 225 \text{ kW}$$

Yukarıdaki güç ve devir değeri kullanılarak bu katalogta anlatılan seçim presüdüğü ile redüktör seçimi yapılabilir.

#### Equivalent Power Rating Sample

The following data is given for a reversing blooming mill;

##### Torque steps:

Total one cycle time: 2 min.

1st torque part: 48 kNm, 30 s

2nd torque part: 32 kNm, 22 s

3th torque part: 28 kNm, 15 s

4th torque part: 16 kNm, 10 s

5th torque part: 5 kNm, 43 s

Machine constant speed: 50 rpm

The equivalent power, which is required for gear unit selection, is to determine.

##### Solution:

Total time in a cycle;

$$t = t_1 + t_2 + t_3 + t_4 + t_5 = 120 \text{ sn}$$

Equivalent Torque;

$$T_e = \left( \frac{30 \times 48^{6.6} + \dots + 43 \times 5^{6.6}}{120} \right)^{\frac{1}{6.6}}$$
$$= 39,2 \text{ kNm}$$

50% of Equivalent torque;

$$0.5 \times T_e = 19.6 \text{ kNm}$$

Every torque part must be lower then this value;

$$T_4, T_5 < 0.5 \times T_e$$

We are repeating the calculation by taking out the torque parts, which are below 50%;

$$t' = t - t_4 - t_5 = 120 - 43 - 10 = 67 \text{ s}$$

$$T_e = \left( \frac{30 \times 48^{6.6} + \dots + 15 \times 28^{6.6}}{67} \right)^{\frac{1}{6.6}}$$
$$= 42,9 \text{ kNm}$$

By using the equivalent torque and constant speed we calculate the equivalent power ;

$$P_{eq} = \frac{T_e \times n}{9550} = \frac{42,9 \times 1000 \times 50}{9550} \cong 225 \text{ kW}$$

Now by using the above calculated equivalent power and constant speed we can make the gearbox selection with the procedures described in this catalogue.

#### Beispiel für Äquivalente Leistung

Die nachfolgenden Angaben sind für eine Blechreversierwalze;

##### Drehmoment stufen:

Gesamte Zeit für einem Arbeitszyklus: 2 min.

Drehmomentanteil 1: 48 kNm 30 s

Drehmomentanteil 2: 32 kNm 22 s

Drehmomentanteil 3: 28 kNm 15 s

Drehmomentanteil 4: 16 kNm 10 s

Drehmomentanteil 5: 5 kNm 43 s

Maschine hat konstante Drehzahl: 50 U/min

Gesucht ist die äquivalente Leistung, die für die Getriebeauslegung nötig ist.

##### Lösung:

Gesamte Zeit für einem Arbeitszyklus;

$$t = t_1 + t_2 + t_3 + t_4 + t_5 = 120 \text{ sn}$$

Äquivalentes Drehmoment;

$$T_e = \left( \frac{30 \times 48^{6.6} + \dots + 43 \times 5^{6.6}}{120} \right)^{\frac{1}{6.6}}$$
$$= 39,2 \text{ kNm}$$

50% von äquivalenten Drehmoment;

$$0.5 \times T_e = 19.6 \text{ kNm}$$

Drehmomentanteile müssen größer als dieser Wert sein;

$$T_4, T_5 < 0.5 \times T_e$$

Wir wiederholen die Berechnung nochmals ohne die kleine Drehmomentanteile;

$$t' = t - t_4 - t_5 = 120 - 43 - 10 = 67 \text{ s}$$

$$T_e = \left( \frac{30 \times 48^{6.6} + \dots + 15 \times 28^{6.6}}{67} \right)^{\frac{1}{6.6}}$$
$$= 42,9 \text{ kNm}$$

Mit Hilfe von äquivalenten Drehmoment und konstanter Drehzahl berechnet man die äquivalente Leistung ;

$$P_{eq} = \frac{T_e \times n}{9550} = \frac{42,9 \times 1000 \times 50}{9550} \cong 225 \text{ kW}$$

Nach Bestimmung der äquivalente Leistung und konstanter Drehzahl, erfolgt die Getriebeauslegung dann wie die Getriebeauswahl gemäß dem in diesem Katalog beschriebenen Verfahren für konstante Leistung.



# Genel Bilgiler

## General Information

### Einführung



#### Redüktör Seçimi

Bir redüktör seçiminde aşağıdaki yol izlenmelidir.

1. Çalışma şartlarına bağlı olarak servis faktörünü (fs) belirleyiniz. (Servis Faktörü Sayfa 16).
2. Makinanız için gerekli olan momenti belirleyiniz  $M_2$  (redüktör gerekli çıkış momenti).
3. Makinanızın devrini belirleyiniz  $n_2$  (redüktör gerekli çıkış devri).
4. Makinanızın güç ihtiyacını (Redüktör çıkış gücünü) "P<sub>2</sub>" hesaplayınız.

$$P_2 = \frac{M_2 \times n_2}{9550}$$

5. Redüktör ile makina arasında kullanılan bağlantı elemanına göre radyal yükü hesaplayınız. (Sayfa 20). Yukarıdaki verilere uygun olarak çıkış devri, değerlerine uyan servis faktörü ve radyal yükü bulduğunuzdan daha yüksek veya eşit olan redüktörü, güç-devir seçim tablolarından seçiniz. Helisel tip redüktörlerde verim yüksek olduğundan çıkış gücü verilmemiştir. Hesapladığınız güç değerini giriş gücü olarak kabul edip seçiminizi yapınız. Tablolarda verilen  $M_2$  çıkış momentinin hesapladığınız  $M_2$  den büyük olmasına dikkat ediniz. Eğer seçilen redüktörünki daha ufak ise bir üst motor gücüne geçiniz.

#### Örnek

##### 1. Makina Cinsi:

Lastik bantlı konveyör , dökme yük taşıyor.

##### 2. Makina için gerekli moment:

Makina için hesaplanan moment  $M_2 = 400 \text{ Nm}$ .

##### 3. Makina gerekli çıkış devri:

$n_2 = 54 \text{ dev/dak}$ .

##### 4. Günlük çalışma süresi:

16 saat.

##### 5. Saatte start sayısı:

Saatte 1 start

##### 6. Makina ile bağlantı şekli:

Zincir dişli ( çap -130 mm )

- Yük sınıflandırma tablosundan yük sınıfı M olarak seçilir (sayfa 17-18)

- Günlük çalışma süresi 16 saat Saatte start sayısı 1 ve yük sınıfı M'ye tekabül eden servis faktörü tablosundan, servis faktörü için fs= 1.3 değeri bulunur.(sayfa 16)

- Makinanızın güç ihtiyacı (Redüktör Çıkış Gücü) :

$$P_2 = \frac{M_2 \times n_2}{9550} = \frac{470 \times 50}{9550} = 2,46 \text{ kW}$$

#### Gearbox Selection

For the correct selection of the appropriate gear units follow this steps.

1. Determine service factor (fs) on the basis of running conditions (Page 16).
2. Determine the required Torque  $M_2$  (required output torque of gearbox) for the driven machine.
3. Determine required speed (output speed of gearbox) for the driven machine.
4. Calculate the required power for your machine (Calculate power "P<sub>2</sub>" required at output side of gear reducer using the formula);

$$P_2 = \frac{M_2 \times n_2}{9550}$$

5. Calculate overhung load required at output shaft according to type of connection between gear unit and machine (Refer to directions and values given on page 20). After determining the above mentioned values, the gear reducer which corresponds to our requirements can be selected from the performance tables (the service factor and the permissible overhung load should be less than or equal to our requirement). For Helical gears the output power is not given on the performance tables because they have high efficiency and the output power can be taken as input power. The output torque should be checked if it meets to our requirements. If the output torque is low, search for a higher input power gearbox.

#### Example:

##### 1. Machine Type:

Belt Conveyor (Bulk Load)

##### 2. Required Torque:

Required Torque calculated for the driven machine is  $M_2=400 \text{ Nm}$ .

##### 3. Required speed:

$n_2 = 50 \text{ rpm}$

##### 4. Running time:

16 hours per day

##### 5. Frequency of starting:

1 start per hour

##### 6. Connection type between gear reducer

Chain drive (output dimension-130 mm)

- From the load classification table (on page 17-18), the load class M can be selected for the known application.

- The service factor can be selected as fs =1,3 from the service factor table (page 16) by taking into consideration 16 hours running time, one start per hour, and load class M.

-Required power for your machine(Power at output side of gear reducer) :

$$P_2 = \frac{M_2 \times n_2}{9550} = \frac{470 \times 50}{9550} = 2,46 \text{ kW}$$

#### Getriebeauswahl

Für die korrekte Auswahl des Antriebes;

1. Den Betriebsfaktor(fs) in Abhängigkeit von den Betriebsbedingungen bestimmen.(Bezug auf Seite 16).
2. Die erforderte Drehmoment  $M_2$  für die angetriebene Maschine (Abtriebsdrehmoment für die Getriebe) bestimmen.
3. Erforderte Drehzahl bestimmen (Abtriebsdrehzahl für die Getriebe).
4. Berechnen der erforderte Leistung der angetriebene Maschine (Die an der Abtriebswelle erforderte Leistung "P<sub>2</sub>") mit der unten angegebenen Formel.

$$P_2 = \frac{M_2 \times n_2}{9550}$$

5. Die an der Getriebeabtriebswelle erforderte Querkraft in Abhängigkeit von Antriebsselement bestimmen (Bezug auf Seite 20). Nach Bestimmen der oben angegebenen Werte, die passende Getriebe kann von den angegebenen Leistungstabellen entnommen werden. Dabei soll darauf geachtet werden, dass der Betriebsfaktor und Querkraft stets unterhalb von angegebenen Werten liegt. Weil Stirnradgetrieben einen hohen Wirkungsgrad haben, sind die Abtriebsleistungen für Stirnradgetrieben nicht angegeben. Bei dieser Getrieben die erforderte Leistung kann als Antriebsleistung benutzt werden. Achten sie darauf, dass der Abtriebsmoment größer als die erforderte Drehmoment ist.

#### Beispiel:

##### 1. Maschinentyp:

Gurtbandförderer (Schüttgut)

##### 2. Erforderte Drehmoment:

Für die Maschine berechnete Drehmoment  $M_2 = 470 \text{ Nm}$ .

##### 3. Erforderte Drehzahl:

$n_2 = 50 \text{ upm}$

##### 4. Betriebsdauer:

16 stunden pro Tag

##### 5. Schalthäufigkeit:

1 Start pro Stunde

##### 6. Antriebsselement für Verbindung mit Getriebe:

Kettentrieb(Durchmesser- 130 mm)

- Von den Belastungsart Tabellen(Seite 17-18) nimmt man Belastungsart M

- Für den Schaltungzahl 1 und die Laufzeit16 und für den passenden Belastungsart erhält man Betriebsfaktor fs =1,3 von Tabelle auf Seite 16.

- Erforderte Leistung der angetriebe Maschine (Die an der Getriebeabtriebswelle erforderte Leistung)

$$P_2 = \frac{M_2 \times n_2}{9550} = \frac{470 \times 50}{9550} = 2,46 \text{ kW}$$



## Genel Bilgiler General Information Einführung



- Zincir dişli uygulaması için (Sayfa 21) Fq değeri;

$$Fq = \frac{2100 \times M_2}{D} = \frac{2100 \times 400}{130} = 6461,53 \text{ N}$$

- Ortaya çıkan redüktör ihtiyacı

$$\begin{aligned} P_2 &\geq 2,46 \text{ kW} \\ M_2 &\geq 400 \text{ Nm} \\ fs &\geq 1,3 \\ n_2 &\approx 50 \text{ d/dak} \\ Fq &\geq 6461,53 \text{ N} \end{aligned}$$

Güç ve devir sayfalarından,

**EV125-100L/4b** seçilir (Sayfa 65).

$$\begin{aligned} P_2 &= 3 \text{ kW} > 2,46 \text{ kW} \\ M_2 &= 447 \text{ Nm} > 400 \text{ Nm} \\ fs &= 1,6 \\ n_2 &= 54 \text{ d/dak} \\ fq &= 8200 \text{ Nm} < 7592 \text{ Nm} \\ i &= 24 \end{aligned}$$

- For chain drive application the requested overhang load can be calculated from (page 21).;

$$Fq = \frac{2100 \times M_2}{D} = \frac{2100 \times 400}{130} = 6461,53 \text{ N}$$

- The required gearbox is as follows:

$$\begin{aligned} P_2 &\geq 2,46 \text{ kW} \\ M_2 &\geq 400 \text{ Nm} \\ fs &\geq 1,3 \\ n_2 &\approx 50 \text{ rpm} \\ Fq &\geq 6461,53 \text{ N} \end{aligned}$$

From the performance table,

**EV125-100L/4b** selected (Page 65).

$$\begin{aligned} P_2 &= 3 \text{ kW} > 2,46 \text{ kW} \\ M_2 &= 447 \text{ Nm} > 400 \text{ Nm} \\ fs &= 1,6 \\ n_2 &= 54 \text{ rpm} \\ fq &= 8200 \text{ Nm} < 7592 \text{ Nm} \\ i &= 24 \end{aligned}$$

- Für Kettentrieb die erforderte Querkraft (seite 21);

$$Fq = \frac{2100 \times M_2}{D} = \frac{2100 \times 400}{130} = 6461,53 \text{ N}$$

- Von den oben angegebenen Berechnungen die erforderte Getriebe ist wie folgt;

$$\begin{aligned} P_2 &\geq 2,46 \text{ kW} \\ M_2 &\geq 400 \text{ Nm} \\ fs &\geq 1,3 \\ n_2 &\approx 50 \text{ U/min} \\ Fq &\geq 6461,53 \text{ N} \end{aligned}$$

Von der Leistung- Drehzahltable ,

wurde **EV125-100L/4b** gewählt (Seite 65).

$$\begin{aligned} P_2 &= 3 \text{ kW} > 2,46 \text{ kW} \\ M_2 &= 447 \text{ Nm} > 400 \text{ Nm} \\ fs &= 1,6 \\ n_2 &= 54 \text{ u/min} \\ fq &= 8200 \text{ Nm} < 7592 \text{ Nm} \\ i &= 24 \end{aligned}$$



# Genel Bilgiler

## General Information

### Einführung



#### Redüktör Seçim Formu

Kullanıldığı Sektör.....  
Kullanıldığı Yer.....  
Gerekli Ortalama Devir.....d/dak

#### Makina ihtiyaç gücü:

-Normal..... kW  
-En çok..... kW  
-En az..... kW

#### Tahrik Şekli:

AC Motor [ ]  
AC Motor + Invertör [ ]  
DC Motor [ ]  
1-3 silindirli içten yanmalı [ ]  
2-4 silindirli içten yanmalı [ ]

#### Motor Bağlantı Şekli (Elektrik Motorları):

IEC B5/B14 Flanşlı [ ]  
NEMA Flanşlı [ ]  
B3 Ayaklı [ ]  
Direkt Akuple [ ]

IEC veya NEMA flanş kodu. ....

#### Motor Gücü:

-Nominal..... kW

#### Motor Devri:

-Normal..... d/dak  
-En çok..... d/dak  
-En az..... d/dak

#### Motor Torku:

-Normal..... Nm  
-En çok..... Nm  
-En az..... Nm

#### Dönüş şekli:

saat yönü [ ] saat yönüne ters [ ] değişken [ ]

#### Günlük çalışma süresi:

<4 [ ] 4-8 [ ] 8-16 [ ] >16 [ ]

#### Saatdeki start sayısı:

0-50 [ ] 50-100 [ ] 100-200 [ ]  
200-300 [ ] 300-500 [ ] 500-700 [ ]  
700-1000 [ ] >1000 [ ]

Motor Redüktör Arası Tahvil Oranı.....

Kalkış için gerekli moment.....Nm

#### Saatdeki pik moment adedi:

1-5 [ ] 6-30 [ ] 31-100 [ ] >100 [ ]

#### Bir çevrimde aktif çalışma oranı (ED):

%100 [ ] %80 [ ] %60 [ ] 40% [ ] %20 [ ]

#### Deniz seviyesinden yükseklik:

<1000 [ ] <2000 [ ] <3000 [ ]  
<4000 [ ] <5000 [ ]

#### Montaj yeri:

Küçük kapalı oda (w<1m/sn) [ ]  
Kapalı oda (w<3m/sn) [ ]  
Büyük oda ve holler (w>=3m/sn) [ ]  
Tamamen açık ortam [ ]

#### Çevre Şartları:

Normal [ ] Tozlu [ ] Nemli [ ]  
Korozif [ ] Kuru [ ]

#### Çevre Sıcaklığı:

Ortalama..... °C  
En Yüksek..... °C  
En Düşük..... °C

#### Kilit İhtiyacı:

Var [ ] Yok [ ]

#### Redüktör Giriş Opsiyonu:

R.[ ] V.[ ] N.[ ] T.[ ]

#### Redüktör Çıkış Opsiyonu:

00 [ ] 01 [ ] 02 [ ] 03 [ ] 04 [ ] 05 [ ] 08 [ ]

#### Montaj Pozisyonu:

M1 [ ] M2 [ ] M3 [ ] M4 [ ] M5 [ ] M6 [ ]

#### Giriş mili bağlantı şekli:

Elastik kaplin [ ]  
Fıçı tipi kaplin [ ]  
Rijit kaplin [ ]  
Hidrolik Kaplin [ ]  
Kayış kasnak [ ]  
Zincir dişli [ ]  
Pinyon dişli [ ]  
Bağlantı elemanı çapı.....mm  
Radyal yükü.....N  
Radyal yük "u" mesafesi.....mm  
Aksiyal yükü (mile doğru +).....N

#### Çıkış mili bağlantı şekli:

Elastik kaplin [ ]  
Fıçı tipi kaplin [ ]  
Rijit kaplin [ ]  
Kayış kasnak [ ]  
Zincir dişli [ ]  
Pinyon dişli [ ]  
Delik milli tork kolu [ ]  
Sıkma bilezikli tork kolu [ ]  
Bağlantı elemanı çapı.....mm  
Radyal yükü.....N  
Radyal yük "u" mesafesi.....mm  
Aksiyal yükü (mile doğru +).....N

#### Çıkış Mili Özelliği:

Dolu Mil Kamalı [ ]  
Dolu Mil Kamasız [ ]  
Delik Milli [ ]  
Özel Mil [ ]

#### Giriş Mili Özelliği:

Kamalı [ ]  
Kamasız düz mil [ ]  
Özel Mil [ ]  
Tork kolu [ ] Var [ ] Yok [ ]

#### Elektrik Gerilimi:

AC-Monofaze [ ] AC-Trifaze [ ] DC [ ]  
Voltaj.....Volt  
Frekans.....Hz

#### Koruma Sınıfı:

IP55 [ ] IP65 [ ] Exproof [ ]  
Diğer IP.....

#### Ekler:

Yük diyagramı [ ]  
Proje [ ]  
İstenen ana boyutlar [ ]  
Teknik veriler [ ]

#### Diğer Notlar:



# Genel Bilgiler

## General Information

### Einführung



#### Gearbox Selection Form

Field of Industry.....  
 Application.....  
 Required Average Speed..... rpm

#### Required Power on Driven Machine:

-Normal..... kW  
 -Maximum..... kW  
 -Minimum..... kW

#### Driving Machine:

AC Motor [ ]  
 AC Motor + Inverter [ ]  
 DC Motor [ ]  
 Hydraulic Motor [ ]  
 Piston Engine with 1-3 cylinder [ ]  
 Piston Engine with 4-24 cylinder [ ]

#### Motor Connection Type (Electric Motors):

IEC B5/B14 Flange [ ]  
 NEMA Flange [ ]  
 B3 Foot Mounted [ ]  
 Direct Coupled [ ]

IEC or NEMA Flange Code.....

#### Motor Power:

-Nominal.....kW

#### Motor Speed:

-Normal.....rpm  
 -Maximum.....rpm  
 -Minimum.....rpm

#### Motor Torque:

-Normal.....Nm  
 -Maximum.....Nm  
 -Minimum.....Nm

#### Direction of Rotation:

cw [ ] ccw [ ] variable [ ]

#### Working hours per day:

<4 [ ] 4-8 [ ] 8-16 [ ] >16 [ ]

#### Startings per cycle:

0-50 [ ] 50-100 [ ] 100-200 [ ]  
 200-300 [ ] 300-500 [ ] 500-700 [ ]  
 700-1000 [ ] >1000 [ ]

Transmission ratio between motor and gear unit.....

Required Starting Torque.....Nm

#### Peak torques per hour:

1-5 [ ] 6-30 [ ] 31-100 [ ] >100 [ ]

#### Effective working time in a cycle (ED):

%100 [ ] %80 [ ] %60 [ ] 40% [ ]  
 20% [ ]

#### Altitude:

<1000 [ ] <2000 [ ] <3000 [ ]  
 <4000 [ ] <5000 [ ]

#### Mounting Place:

Small closed room (w<1m/sn) [ ]  
 Closed room (w<3m/sn) [ ]  
 Big rooms and halls (w>=3m/sn) [ ]  
 Outdoor [ ]

#### Ambient Conditions:

Normal [ ] Dusty [ ] Humid [ ]  
 Corrosive [ ] Dry [ ]

#### Ambient Temperature:

Average.....°C  
 Maximum.....°C  
 Minimum.....°C

#### Backstop Required:

Yes [ ] No [ ]

#### Gearbox input options:

V.[ ] N.[ ] T.[ ]

#### Gearbox output options:

00 [ ] 01 [ ] 02 [ ] 03 [ ] 04 [ ] 05 [ ] 08 [ ]

#### Mounting Position:

M1 [ ] M2 [ ] M3 [ ] M4 [ ] M5 [ ] M6 [ ]

#### Input Shaft Connection Type:

Elastic Coupling [ ]  
 Barrel Type Coupling [ ]  
 Hydraulic Coupling [ ]  
 Rigid Flange Coupling [ ]  
 Pulley [ ]  
 Chain Sprocket [ ]  
 Pinion [ ]  
 Diameter of Connection element.....mm  
 Radial Load.....N  
 "u" Distance of Radial Load.....mm  
 Axial Load (Towards Shaft) .....N

#### Output Shaft Connection Type:

Elastic Coupling [ ]  
 Barrel Type Coupling [ ]  
 Rigid Flange Coupling [ ]  
 Pulley [ ]  
 Chain Sprocket [ ]  
 Pinion [ ]  
 Hollow Shaft with Torque Arm [ ]  
 Schrink disc with Torque Arm [ ]  
 Diameter of Connection Element.....mm  
 Radial Load.....N  
 "u" Distance of Radial Load.....mm  
 Axial Load (Towards Shaft) .....N

#### Gearbox assembled by:

Foot [ ] Flange [ ] Torque Arm [ ]

#### Output Shaft Specification:

Solid Shaft with Keyway [ ]  
 Solid Shaft without Keyway [ ]  
 Hollow Shaft [ ]  
 Special Shaft [ ]

#### Input Shaft Specification:

Solid Shaft with Keyway [ ]  
 Solid Shaft without Keyway [ ]  
 Special Shaft [ ]  
 Torque arm required Yes [ ] No [ ]

#### Electrical Supply:

AC-1 Phase [ ] AC-3 Phase [ ] DC [ ]  
 Voltage.....Volt  
 Frequency..... Hz

#### Protection Class:

IP55 [ ] IP65 [ ] Exproof [ ]  
 Other IP.....

#### Attachments:

Load Diagram [ ]  
 Project [ ]  
 Required Dimensions [ ]  
 Technical Specifications [ ]

#### Notes:



# Genel Bilgiler

## General Information

### Einführung



#### Formular für Getriebeauswahl

Industriebereich.....  
 Anwendung.....  
 Erforderliche Drehzahl.....U/min

#### Erforderliche Leistung für die Maschine:

-Normal.....kW  
 -Minimal.....kW  
 -Maximal.....kW

#### Antriebsmaschine:

AC Motor [ ]  
 AC Motor mit Frequenzumrichter [ ]  
 DC Motor [ ]  
 Kolbenmaschinen mit 1-3 Zylinder [ ]  
 Kolbenmaschinen mit 2-4 Zylinder [ ]

#### Motorverbindungsart (Elektromotoren):

IEC B5/B14 Flansch [ ]  
 NEMA Flansch [ ]  
 B3 Fussausführung [ ]

IEC oder NEMA Flanschcode.....

#### Motorleistung:

-Nominal.....kW

#### Motordrehzahl:

-Normal.....U/min  
 -Maximal .....U/min  
 -Minimal.....U/min

#### Motordrehmoment:

-Normal.....Nm  
 -Maximal.....Nm  
 -Minimal.....Nm

#### Drehrichtung:

in Uhrzeigersinn [ ] gegen Uhrzeigersinn [ ]  
 veränderlich [ ]

#### Betriebsdauer in Stunden pro Tag:

<4 [ ] 4-8 [ ] 8-16 [ ] >16 [ ]

#### Anzahl der Anläufe pro Stunde:

0-50 [ ] 50-100 [ ] 100-200 [ ]  
 200-300 [ ] 300-500 [ ] 500-700 [ ]  
 700-1000 [ ] >1000 [ ]

Übersetzung zwischen Motor und Antriebswelle.....

Erforderliches Anlaufmoment.....Nm

#### Häufigkeit von Lastspitzen pro Stunde:

1-5 [ ] 6-30 [ ] 31-100 [ ] >100 [ ]

#### Einschaltdauer je Stunde (ED):

%100 [ ] %80 [ ] %60 [ ] 40% [ ] %20 [ ]

#### Höhenlage über Meeresspiegel (m):

<1000 [ ] <2000 [ ] <3000 [ ]  
 <4000 [ ] <5000 [ ]

#### Betriebsort:

Kleine geschlossene Räume (w<1m/sn) [ ]  
 Geschlossene Räume (w<3m/sn) [ ]  
 Große Räume und Hallen (w>=3m/sn) [ ]  
 im Freien [ ]

#### Umgebungsbedingungen:

Normal [ ] Staubig [ ] Feucht [ ]  
 Korrodierend [ ] Trocken [ ] Verklebend [ ]

#### Umgebungstemperatur:

Mittelwert ..... °C  
 Maximal..... °C  
 Minimal..... °C

#### Rücklaufsperre erforderlich:

Ja [ ] Nein [ ]

#### Getriebeeingangsvarianten:

V.[ ] N.[ ] T.[ ]

#### Getriebeausgangsvarianten:

00 [ ] 01 [ ] 02 [ ] 03 [ ] 04 [ ] 05 [ ] 08 [ ]

#### Montageposition:

M1 [ ] M2 [ ] M3 [ ] M4 [ ] M5 [ ] M6 [ ]

#### Antriebswellenanschluss:

Elastische Kupplung [ ]  
 Trommelkupplung [ ]  
 Hydrokupplung [ ]  
 Starre Flanschkupplung [ ]  
 Riementrieb [ ]  
 Kettenrad [ ]  
 Ritzel [ ]  
 Durchmesser von Anslusselement.....mm  
 Querkraft.....N  
 "u" Abstand von der Wellenschulter.....mm  
 Axialkraft (in Richtung der Welle +) .....N

#### Abtriebswellenanschluss:

Elastische Kupplung [ ]  
 Trommelkupplung [ ]  
 Starre Flanschkupplung [ ]  
 Riementrieb [ ]  
 Kettenrad [ ]  
 Ritzel [ ]  
 Hohlwelle mit Drehmomentstütze [ ]  
 Schrumpfscheibe mit Drehmomentstütze [ ]  
 Durchmesser von Anslusselement.....mm  
 Querkraft.....N  
 "u" Abstand von der Wellenschulter.....mm  
 Axialkraft (in Richtung der Welle +) .....N

#### Montage zur Getriebegehäuse mit:

Fuß [ ] Flansch [ ] Drehmomentstütze [ ]

#### Eigenschaften der Abtriebswelle:

Vollwelle mit Passfeder [ ]  
 Vollwelle ohne Passfeder [ ]  
 Hohlwelle [ ]  
 Sonderwelle [ ]

#### Eigenschaften der Antriebswelle:

Vollwelle mit Paßfeder [ ]  
 Vollwelle ohne Paßfeder [ ]  
 Sonderwelle [ ]  
 Drehmomentstütze erforderlich Ja [ ] Nein [ ]

#### Spannungsversorgung:

AC-1 phasig [ ] AC-3 phasig [ ] DC [ ]  
 Spannung.....Volt  
 Frequenz.....Hz

#### Schutzart:

IP55 [ ] IP65 [ ] Exproof [ ]  
 Andere IP.....

#### Anhang:

Lastdiagramm [ ]  
 Projekt [ ]  
 Erforderliche Abmessungen [ ]  
 Technische Spezifikationen [ ]

#### Andere Merkmale:



## Genel Bilgiler General Information Einführung



### Yağlama

Redüktörlerin uzun ömürlü olması ve iyi performansla çalışabilmesi için, kullanılan yağın seçimi doğru olmalı ve belirtilen zamanlarda değişimleri yapılmalıdır.

Yağın seçiminde devir, çevre sıcaklığı, redüktör yağ sıcaklığı, çalışma koşulları ve yağ ömrü önem taşımaktadır. Redüktörler yağı doldurulmuş olarak sevkedilmektedir. Redüktörler uzun süre depolanacakları zaman veya çalışmaya başlanacağı zaman çalışma konumuna göre üstte kalan tapa sökülmeli ve redüktörün beraberinde verilen havalandırma tapası kullanılmalıdır. Bu redüktörün iç basıncından dolayı oluşacak yağ sızmalarını önleyecektir.

Redüktörlerde standart olarak kullanılan yağlar yan sayfadaki tabloda verilmiştir. Eğer Siparişte belirtilmezse Sonsuz Redüktörler M1 pozisyonuna göre yağ ile doldurulmuştur. Bu pozisyonlar dışındaki çalışma durumlarında tablolarda verilen yağ miktarlarına göre ilave veya eksiltme yapılmalıdır. Özel çalışma koşullarında firmamıza danışmanız tavsiye edilir.

Mineral yağlar her 10.000 çalışma saatinde, sentetik yağlar ise her 20.000 çalışma saatinde değiştirilmelidir. Ağır çevre koşullarında (ani ısı değişiklikleri, yüksek nemlilik v.b) yağ değiştirme periyotlarının kısaltılması tavsiye edilir. Mineral yağlar ile sentetik yağlar birbirine kesinlikle karıştırılmamalıdır. Değiştirme işlemi bir çalışma periyodunun hemen peşinden ve yağ sıcakken yapılmalıdır. Bu şekilde bir değiştirme, redüktör içindeki partiküllerin yağa karışmış olarak bulunmasından dolayı iyi bir temizleme ve yağın rahat boşalması neticesini verecektir.

Redüktörlerde kullanılan yağ tipi için etiketine bakınız.

### Lubrication

*To work in perfect condition and to have long life for the gearbox the lubricant must be chosen correctly and changed in time.*

*In selection of oil it is important to consider speed, ambient temperature, gear box oil temperature, working conditions and the life required from the lubricant. All units are filled with lubricant before shipping. Before the gearbox is stored for a long time or before starting up, the top plug (according to the working position) must be removed and the extra given vent plug must be replaced. This prevents excessive pressure which causes oil leakages.*

*The lubricant in the standard line is given for standard fillings on the table below. If the mounting position not indicated on order Worm Geared gearboxes are filled with mounting position of M1. For other mounting positions please filling oil or draining oil refer to the table given on the next pages. For special working conditions please contact us.*

*The mineral lubricant should be changed after every 10.000 service hours and the synthetic lubricant should be changed after every 20.000 working hours. If the operation conditions are very heavy (e.g. high temperature differences, high humidity) shorter intervals between changes are recommended. Mineral and synthetic oils must not be mixed up. By changing the lubricant complete cleaning is advised. The oil change should be done after a working period. Because oil is hot in this condition and impurities are mixed with it the changing of oil will be done in best result and the oil will drain easily.*

*Please look at the label of your gear unit to check the filled oil type of gear unit.*

### Schmierung

Um eine lange Lebensdauer zu gewährleisten muss der Schmierstoff richtig ausgewählt werden.

Für die richtige Ölauswahl müssen Drehzahl, Umgebungstemperatur, Belastungsart und Lebensdauer des Öls berücksichtigt werden. Die mitgelieferte Entlüftungsschraube ist vor Inbetriebnahme oder längeren Lagern gegen die Einfüllschraube auszutauschen, um einen Überdruck im Getriebe und damit eine Undichtigkeit des Getriebes zu vermeiden. Getriebe und Getriebemotoren sind bei Auslieferung betriebsfertig gefüllt.

Ohne besondere Bestellangaben werden die Getriebe grundsätzlich mit den auf der folgenden Seite in der grau unterlegten Spalte angegebenen Schmierstoffen gefüllt. Die fußbefestigten Getriebe sind befüllt für Bauform und die flanschbefestigten Getriebe für Bauform M1. Für andere Bauformen sind die auf der nächsten Seite angegebenen Füllmengen zu beachten.

Ein Schmierstoffwechsel sollte alle 10.000 Betriebsstunden durchgeführt werden. Für synthetische Produkte verdoppeln sich diese Fristen. Bei extremen Betriebsbedingungen, z.B. hohe Luftfeuchtigkeit, aggressiver Umgebung und hohen Temperatur-schwankungen sind kürzere Schmierstoffintervalle vorteilhaft. Es ist empfehlenswert, dem Schmierstoffwechsel mit einer gründlichen Reinigung des Getriebes zu verbinden. Synthetische und mineralische Schmierstoffe dürfen nicht miteinander vermischt werden. Das Ablassen des Öls soll unmittelbar nach dem Stillsetzen erfolgen, solange das Öl noch warm ist. In dieser Zustand ist das Öl mit den Smutzpartikeln vermischt, so dass eine Entfernung des Altöls eine gute Reinigung garantiert.

Bitte im Getriebe verwendetes Öl von dem Namensschild ablesen.



# Genel Bilgiler

## General Information

### Einführung



#### Yağ Tipleri / Oil Types / Schmierstoffe

Yağ Cinsi Lubricant Art des Schmierers	DIN 51517-3	Çevre Sıcaklığı [°C] Ambient Temperature [°C] Umgebungstemperatur [°C]		ISO VG	Aral	Beyond Petroleum	Castrol	Klüber Lubrication	Mobil	Shell	Total
		Daldırma Yağlama Dip Lubrication Tauchschmier.	Basınçlı Yağlama Forced Lubrication Druckschmier.								
Mineral Yağlar Mineral Oil Mineralöl	CLP	0 ... +50	-	680	Degol BG 680	Energol GR-XP 680	Alpha SP 680	Klüberoil GEM 1-680 N	Mobilgear XMP 680	Omala 680	Carter EP 680
		-5 ... +45	-	460	Degol BG 460	Energol GR-XP 460	Alpha SP 460	Klüberoil GEM 1-460 N	Mobilgear XMP 460	Omala F460	Carter EP 460
		-10 ... +40	+15 ... +40	320	Degol BG 320	Energol GR-XP 320	Alpha SP 320	Klüberoil GEM 1-320 N	Mobilgear XMP 320	Omala F320	Carter EP 320
		-15 ... +30	+10 ... +30	220	Degol BG 220	Energol GR-XP 220	Alpha SP 220	Klüberoil GEM 1-220 N	Mobilgear XMP 220	Omala F220	Carter EP 220
		-20 ... +20	+5 ... +20	150	Degol BG 150	Energol GR-XP 150	Alpha SP 150	Klüberoil GEM 1-150 N	Mobilgear XMP 150	Omala 150	Carter EP 150
		-25 ... +10	+3 ... +10	100	Degol BG 100	Energol GR-XP 100	Alpha SP 100	Klüberoil GEM 1-100 N	-	Omala 100	Carter EP 100
Sentetik Yağlar Synthetic Oil Synthetisches Öl	CLP PG	-10 ... +60	-	680	Degol GS 680	Energyn SG-XP 680	-	Klübersynth GH 6 -680	Mobil Glygoyle 680	Tivela S 680	Carter SY 680
		-20 ... +50	-	460	Degol GS 460	Energyn SG-XP 460	Aphasyn PG 460	Klübersynth GH 6 -460	Mobil Glygoyle 460	Tivela S 460	Carter SY 460
		-25 ... +40	+5 ... +40	320	Degol GS 320	Energyn SG-XP 320	Aphasyn PG 320	Klübersynth GH 6 -320	Mobil Glygoyle 320	Tivela S 320	Carter SY 320
		-30 ... +30	0 ... +30	220	Degol GS 220	Energyn SG-XP 220	Aphasyn PG 220	Klübersynth GH 6 -220	-	Tivela S 220	Carter SY 220
		-35 ... +20	-5 ... +20	150	Degol GS 150	Energyn SG-XP 150	Aphasyn PG 150	Klübersynth GH 6 -150	-	Tivela S 150	Carter SY 150
		-40 ... +10	-8 ... +10	100	-	-	-	Klübersynth GH 6 -100	-	-	-
	CLP HC	-10 ... +60	-	680	-	-	-	Klübersynth GEM 4-680 N	Mobilgear SHC XMP 680	-	Carter SH 680
		-20 ... +50	-	460	Degol PAS 460	Energyn EP-XF 460	Alphasyn T 460	Klübersynth GEM 4-460 N	Mobilgear SHC XMP 460	Omala HD 460	Carter SH 460
		-25 ... +40	+5 ... +40	320	Degol PAS 320	Energyn EP-XF 320	Alphasyn T 320	Klübersynth GEM 4-320 N	Mobilgear SHC XMP 320	Omala HD 320	Carter SH 320
		-30 ... +30	0 ... +30	220	Degol PAS 220	Energyn EP-XF 220	Alphasyn T 220	Klübersynth GEM 4-220 N	Mobilgear SHC XMP 220	Omala HD 220	Carter SH 220
		-35 ... +20	-5 ... +20	150	Degol PAS 150	Energyn EP-XF 150	Alphasyn T 150	Klübersynth GEM 4-150 N	Mobilgear SHC XMP 150	Omala HD 150	Carter SH 150
		-40 ... +10	-8 ... +10	100	-	-	-	Klübersynth GEM 4-100 N	-	-	-
Gıda Uyumlu Yağ Food Grade Oil Schmierung für Lebensmittelöl	CLP NSF H1	-15 ... +25	+5 ... +25	320	-	-	Optileb GT 320	Klüberoil 4 UH1-320 N	Mobil SHC Cibus 320	Cassida Fluid GL-320	Nevastane SL 320
Çevre Dostu Yağ Biodegradable Oil Biologisch abbaubar Öl	CLP E	-25 ... +40	+5 ... +40	320	-	-	Tribol BioTop 1418-320	Klübersynth GEM 2-320	-	-	Carter Bio 320
Mineral Gresler [ -20 ... +130 Çalışma Sıcaklığı °C] Mineral Grease [ -20 ... +130 Working Temperature °C] Mineral-Fett [ -20 ... +130 Betriebstemperatur °C]					Aralub HL3	Energrease LS 3	Speherol AP3	Centoplex 2 EP	Mobilux EP 3	Alvania RL3	Multis Complex EP 2
Sentetik Gresler [ -30 ... +130 Çalışma Sıcaklığı °C] Synthetic Grease [ -30 ... +130 Working Temperature °C] Synthetisches Fett [ -30 ... +130 Betriebstemperatur °C]					-	Energrease SY 2202	-	Petamo GHY 133 N	Mobiltemp SHC 100	Cassida RLS 2	Multis Complex SHD 220



# Genel Bilgiler

## General Information

### Einführung



Montaj Pozisyonları / Mounting Positions / Bauformen

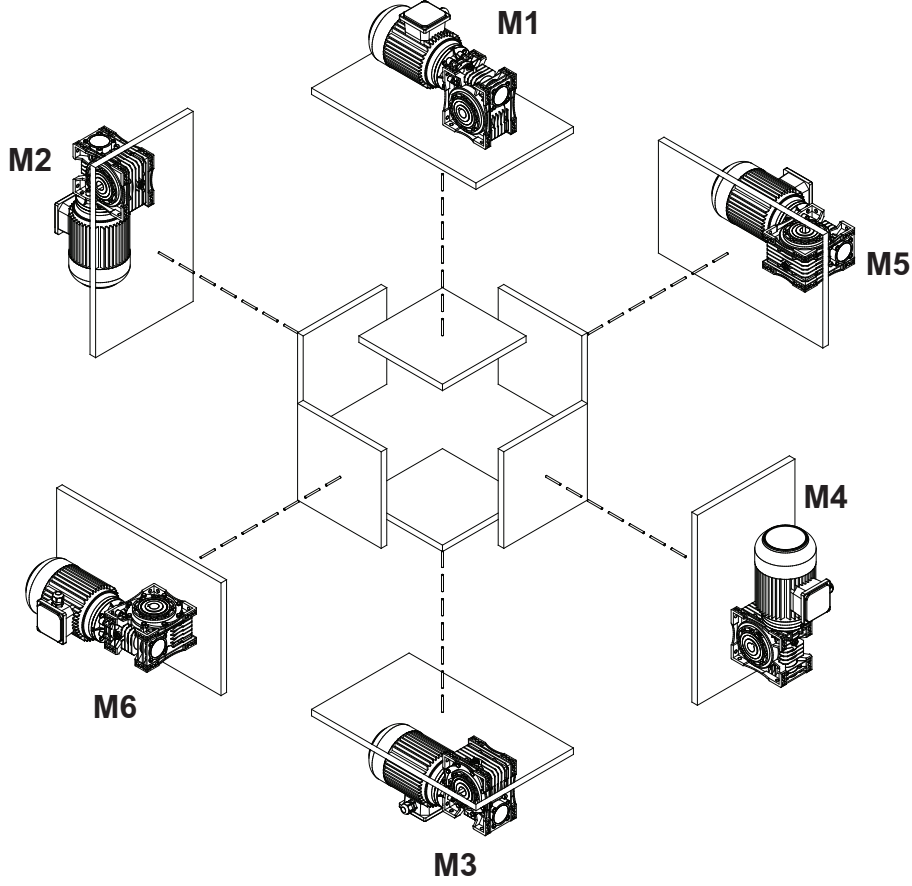

**M1....M6 'ya kadar belirtilen montaj pozisyonları redüktörün duruş yönü referans alınarak belirlenmiştir. Montaj yüzeyleri bağlayıcı değildir.**

*Figured mounting positions of M1 to M6 are determined as reference of directional position of the gearbox. Mounting surfaces are not binding.*

*Dargestellte Montagepositionen M1 bis M6 wurden nach der Stehrichtung von Getriebe bestimmt. Montageoberflächen sind unverbindlich.*



# Genel Bilgiler

## General Information

### Einführung



Yağ Miktarları (lt) / Oil Quantities (lt) / Ölmengen (liter)

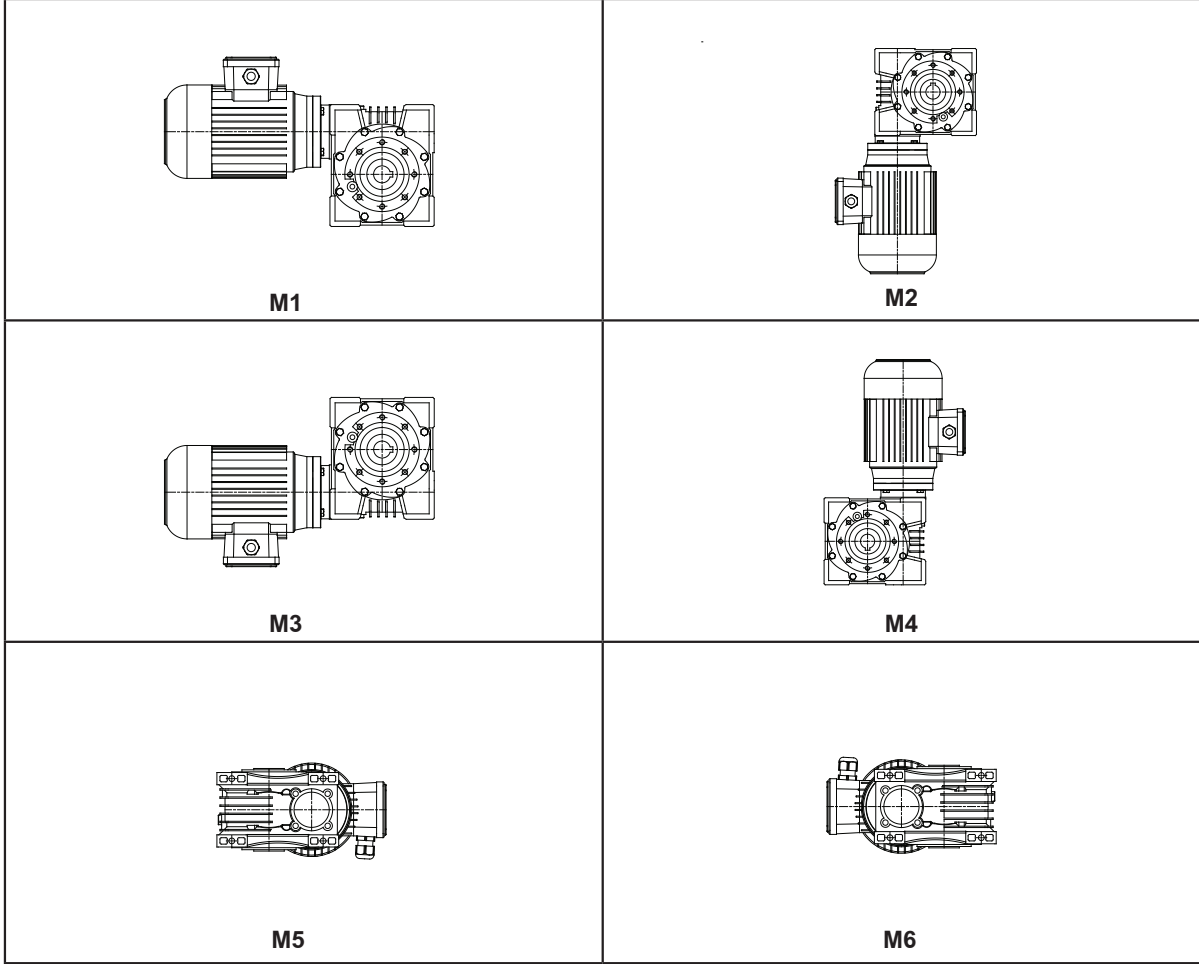

Yağ Miktarları (lt) / Oil Quantities (lt) / Ölmengen (liter)

Tip / Type / Typ	M1	M2	M3	M4	M5	M6
E.30	0,025	0,04	0,02	0,04	0,04	0,04
E.40	0,07	0,10	0,12	0,10	0,10	0,10
E.50	0,15	0,15	0,15	0,15	0,15	0,15
E.63	0,30	0,40	0,26	0,40	0,50	0,40
E.75	0,45	0,65	0,35	0,65	0,65	0,65
E.80	0,60	0,80	0,50	0,80	0,80	0,80
E.100	1,7	2,1	1,2	2,1	2,1	2,1
E.125	3,1	3,6	2,0	3,6	3,6	3,6



# Genel Bilgiler

## General Information

### Einführung



#### MOTORLAR

##### AC Motorlar

##### a- Genel Özellikler:

Basit konstrüksiyonlu, bakım gerektirmez, güvenilirliği yüksek ve uygun fiyatlı olmaları nedeni ile trifaze asenkron motorlar en çok kullanılan motor cinsidir. Bu motorların çalışma karakteristikleri moment-hız eğrisi ile belirlenir. Aşağıda bu karakteristlik eğrisine bir örnek verilmiştir.

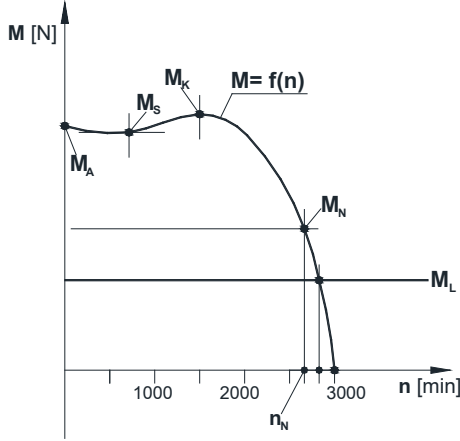

Motorun her start yapılmasında bu eğriye uygun hareket eder ve yük momentini  $M_L$  ile bu eğrinin çakıştığı nokta, motorun çalışma anındaki moment ve devirini verir.

Statorun manyetik alanı senkron hızla  $n_s$  döner. Kutuplar arasındaki faz kayması 3 fazlı motorlarda  $120^\circ$  'dir.

$$n_s = 120 \times \frac{f}{p_s}$$

f.....: şebeke frekansı [Hz]  
p\_s.....: statorun kutup sayısı

Rotorun değişken manyetik alanı rotorun statorun manyetik alanının dönüşü yönünde dönmeye başlamasını sağlar. Rotor bu hareketinde statorun manyetik alanını takip eder ama hiçbir zaman yakalayamaz. Rotor statorun manyetik alanının hızından yavaş döner. Rotorun bu hızına baz hız  $n_N$  denir. Yükün azalması rotorun hızının artmasını sağlar, aynı zamanda sapma azalmış olur. Sapma aşağıdaki gibi belirlenmiştir:

$$s = \frac{n_s - n_N}{n_s} \times 100$$

Sapmanın miktarına göre motorun nominal değerlerinde şu farklılıklar olabilir.

Sapma s .....:  $\pm 20\%$   
Kalkış Akımı.....:  $\pm 20\%$   
Kalkış Momenti.....:  $-15 / +25 \%$   
Kütle Atalet Momenti.....:  $\pm 10\%$   
Verim (37 kW'a kadar).....:  $-0,15 (1-\eta)$

#### MOTORS

##### AC Motors

##### a- General Specifications:

On account of its simple and maintenance free construction, good reliability and price, the three phase squirrel cage motor is one of the most frequently employed electric motors. The run up behavior of a three phase squirrel cage motor is described by the torque-speed characteristic curve. An example is shown below.

$M_A$ : Start moment / Starting torque / Anlaufmoment

$M_S$ : Demeraj moment / Pull-up torque / Anziehungsmoment

$M_K$ : Frenleme moment / Pull-out torque / Bremsmoment

$M_N$ : Motorun iletlediği moment / Motor rated torque / Treibmoment

$M_L$ : Yük moment / Load torque / Lastmoment

The motor follows this torque characteristics up to its stable operating point every time, when it is switched on. Operating point is that point, where the moment speed curve intersects with load torque  $M_L$  line.

The magnetic field in the stator rotates at a synchronous speed  $n_s$ . Phase shift of each pole is  $120^\circ$  at 3 phase motors.

$$n_s = 120 \times \frac{f}{p_s}$$

f.....: supply frequency [Hz]  
p\_s.....: number of stator poles

Because of the alternating magnetic field in the rotor, the rotor starts running in the same direction of the stator flux and tries to catch up with the rotating flux. The rotor never catches up the stator field. The rotor runs slower than the speed of the stator field. This speed is called the base speed  $n_N$ .

A decrease in load will cause the rotor to speed up or decrease slip. The slip is defined as follows:

$$s = \frac{n_s - n_N}{n_s} \times 100$$

According to the slip, the nominal values of the electric motor can alter as follows:

Slip s .....:  $\pm 20\%$   
Starting current .....:  $\pm 20\%$   
Starting torque .....:  $-15 / +25 \%$   
Moment of inertia.....:  $\pm 10\%$   
Efficiency (up to 37 kW).....:  $-0,15 (1-\eta)$

#### MOTOREN

##### Drehstrommotoren:

##### a- Allgemeine Eigenschaften

Wegen die wartungsarme und leichte Konstruktion, hohe Sicherheit bei Nutzung und günstige Preise werden die asynchrone Drehstrommotoren am meisten benutzt. Motoranlaufverhalten wird mit Moment-Drehzahl-Kurve charakterisiert. Ein Beispiel ist unten angegeben.

Der Drehstrommotor läuft diese Kurve bei jeder Anlauf, bis dem stabilen Betriebspunkt erreicht wird. Betriebspunkt ist der Zustand, bei dem die Moment-Drehzahl-Kurve sich mit der Linie von erforderlichen Moment  $M_L$  schneidet.

Magnetisches Feld von Stator dreht sich mit synchroner Geschwindigkeit  $n_s$ . Phasenverschiebung von den Polen ist  $120^\circ$  bei 3 phasigen Drehstrommotoren.

$$n_s = 120 \times \frac{f}{p_s}$$

f.....: Frequenz der Spannung [Hz]  
p\_s.....: Anzahl der Polen von Stator

Durch das magnetische Wechselfeld in den Rotor, beginnt der Rotor sich in der gleichen Richtung des Statorflusses zu drehen und versucht diese Bewegung aufzuholen. Der Rotor kann den Statorfeld nie aufholen. Die Rotorgeschwindigkeit nennt man Basisgeschwindigkeit  $n_N$ . Eine Abnahme der Belastung bewirkt, dass der Rotor sich beschleunigt und der Schlupf sich verringert. Der Schlupf wird wie folgt definiert:

$$s = \frac{n_s - n_N}{n_s} \times 100$$

Für die nominale Werte der Drehstrommotoren sind folgende Abweichungen zulässig:

Schlupf s .....:  $\pm 20\%$   
Anzugsstrom .....:  $\pm 20\%$   
Anzugsmoment .....:  $-15 / +25 \%$   
Massentägheitsmoment .....:  $\pm 10\%$   
Wirkungsgrad (bis 37 kW).....:  $-0,15 (1-\eta)$



# Genel Bilgiler

## General Information

### Einführung



#### b- Çalışma Türleri

Katalogta verilen tüm redüktörlerin motorları S1 çalışma türüne uygun verilmektedir. Diğer çalışma türleri aşağıdaki tabloda gösterilmiştir.

#### b-Modes of Operation

All motors of the catalogue have been laid out for duty S1 (continuous operation). Other duty types are given on the following table.

#### b-Betriebsarten

Die im Katalog angeführten Motoren sind für Betriebsart S1 (Dauerbetrieb) ausgelegt. Andere Betriebsarten sind unten angegeben.

Çalışma Türü Operation Betriebsarten	Açıklama Explanation Erläuterung	Yük Grafiği Load Graphic Lastverläufe
S1	<b>Sabit yükte sürekli çalışma</b> <i>Continuous operation under constant load</i> Dauerbetrieb mit konstanter Belastung	
S2	<b>Sabit yükte kısa süreli çalışma</b> <i>Short-time duty under constant load</i> Kurzbetrieb mit konstanter Belastung	
S3	<b>Yolvermede sıcaklık artımı olmadan periyodik çalışma</b> <i>Periodic duty without influence of start-up on temperature</i> Aussetzbetrieb ohne Einfluß des Anlaufens auf die Temperatur	
S4	<b>Yolvermede sıcaklık artımı olan periyodik çalışma</b> <i>Periodic duty with influence of start up on temperature</i> Aussetzbetrieb mit Einfluß des Anlaufens auf die Temperatur	
S5	<b>Yolvermede ve frenlemede sıcaklık artımı periyodik çalışma</b> <i>Periodic duty with influence of startup and braking on temp.</i> Aussetzbetrieb mit Einfluß des Anlaufens / Bremsung auf die Temp.	
S6	<b>Sürekli orta darbeleri çalışma</b> <i>Continuous operation with intermittent loading</i> Durchlaufbetrieb mit Aussetzungsbelastung	
S7	<b>Elektriksel frenlemeli sürekli orta darbeleri çalışma</b> <i>Continuous operation with intermittent loading and braking</i> Ununterbrochener Betrieb mit Anlauf und Bremsung	
S8	<b>Devir ve yük değişimli sürekli çalışma</b> <i>Continuous operation duty type with related load-speed changes</i> Ununterbrochener periodischer Betrieb mit Drehzahländerung	



# Genel Bilgiler

## General Information

### Einführung



#### c- Koruma Sınıfı:

Yılmaz Redüktörde standart olarak IP54 (IEC 34-5) koruma sınıfı motorlar kullanılmaktadır. Diğer koruma sınıfları istendiğinde firmamıza danışınız.

#### d- İzolasyon Sınıfı:

Yılmaz Redüktörde kullanılan standart izolasyon sınıfı F (IEC 317-8) dir. İstek üzerine H sınıfı yapılabilmektedir.

#### e- Verim Sınıfları:

Üç fazlı az gerilim asenkron motorların verim sınıfı ölçümü IEC 60034-2-1:2007 normu ile belirlenmiştir. Yeni IE verim sınıfı 0,75 kW'tan 375 kW'a kadar güç aralığında çalışan AC motorlar için geçerlidir. EFF verim sınıfından farklı olarak IE verim sınıfı 6 kutup sayılı motorlar içinde kullanılabilir. Aşağıda verim sınıfları sıralanmıştır. Bölgeler dışında verim sınıfı zorunlulukları ülkelere görede farklılık gösterebilir. Lütfen firmamıza danışınız. Başka ürünlere entegre olmuş ve bu nedenle motorun veriminin bağımsız belirlenemediği sistemlerde (redüktör pompa gibi) verim sınıflandırması geçerli değildir.

#### c- Protection Class:

Yılmaz Redüktör uses IP54 (IEC 34-5) protection class electric motors for standard products. If different kind of protection class is requested please contact us.

#### d- Insulation Class:

Yılmaz Redüktör uses F (IEC 317-8) insulation class electric motors for standard products. H insulation class is available upon request.

#### e- Efficiency Classes:

The method for measuring the efficiency of low voltage three-phase asynchronous motors was revised with the new IEC 60034-2-1:2007 standard. The new IE classes is valid for AC Motors in power range from 0,75 to 375 kW. Unlike the EFF classes IE classes can be used for 6-pole AC motors. Below is the table of efficiency classes. The instructions for efficiency classes can differ from country to country. Please contact with us for more information. For the motors, which are fully integrated into a product (for example gear, pump) so their energy efficiency can not be recognized independently, the requirements of efficiency are not valid in Europe.

#### c- Schutzarten:

Yılmaz Redüktör Getriebemotoren werden serienmäßig mit Schutzart IP54 (IEC34-5) ausgeführt. Für andere Schutzarten bitte rückfragen.

#### d- Isolationsklasse:

Yılmaz Redüktör Getriebemotoren werden serienmäßig in Wärmeklasse F (IEC317-8) ausgeführt. H Wärmeklasse ist möglich auf Kundenwunsch.

#### e- Energieeffizienzklassen:

Die Methode für Messung die Effizienz von drei phasigen gering Spannung Asynchronmotoren hat neu mit IEC 60034-2-1:2007 Norm festgestellt. Die neue IE-Klassen gelten für alle Drehstrommotoren im Leistungsbereich von 0,75 bis 375 kW. Anders als EFF-Klassen die IE-Klassen können auch für 6-polige Drehstrommotoren verwendet werden. Unten steht die Tabelle der Effizienzklassen. Die Richtlinien für Effizienzklassen können sich je nach dem Land unterscheiden. Bitte mit unserem Firma Kontakt aufnehmen. Für die Motoren, die vollständig in ein Produkt (zum Beispiel Getriebe, Pumpe) eingebaut sind und deren Energieeffizienz nicht unabhängig von diesem Produkt erfasst werden kann, gelten in Europa die Anforderungen der Effizienzklassen nicht.

Verim Sınıfları Efficiency Classes Energieeffizienzklassen		4 Kutuplu Motor Verim Değeri Hesabı Calculating Efficiency Values of Motors with 4 Poles Berechnung der Wirkungsgrade von Elektromotoren mit 4 Polen	
IE1	EFF 2	<b>Standart Verim</b> Standart Efficiency Standarte Energieeffizienz	A=0,5234 B=-5,0499 C=17,4180 D=74,3171
IE2	EFF 1	<b>Yüksek Verim</b> High Efficiency Hohe Energieeffizienz	A=0,0278 B=-1,9247 C=10,4395 D=80,9761
IE3	-	<b>Premium Verim</b> Premium Efficiency Premium Energieeffizienz	A=0,0773 B=-1,8951 C=9,2984 D=83,7025
IE4	-	<b>Süper Premium Verim</b> Super Premium Efficiency Super Premium Energieeffizienz	-

$$\eta_{Mn} = A \times [\log_{10}(P_L)] + B \times [\log_{10}(P_L)]^2 + C \times \log_{10}(P_L) + D$$

$P_L$  :Anma Yüğü [kW] / Nominal Load [kW] / Nennlast [kW]

$\eta_{Mn}$  :Nominal verim / Nominal Efficiency / Sollwirkungsgrad

4 Kutuplu Motor Verim Değeri Efficiency Values of Motor with 4 poles Sollwirkungsgrad des Motors mit 4 Polen	Anma Yüğü [kW] Nominal Load [kW] Nennlast [kW]	Verim Sınıfı / Efficiency Class / Energieeffizienzklassen		
		IE1	IE2	IE3
	0,75	72,1 %	79,6 %	82,5 %
	1,5	77,2 %	82,8 %	85,3 %
	3	81,5 %	85,5 %	87,7 %
	7,5	86 %	88,7 %	90,4 %
	15	88,7 %	90,6 %	92,1 %
	22	89,9 %	91,6 %	93 %
	37	91,2 %	92,7 %	93,9 %
	45	91,7 %	93,1 %	94,2 %
	75	92,7 %	94 %	95 %
	90	93 %	94,2 %	95,2 %
	330	94 %	95,1 %	96 %



# Genel Bilgiler General Information Einführung



## f- AC Frekans İnvörtörler

Doğru Akımı (DC), alternatif akıma (AC) çeviren elektronik çeviricilere invertör denilmektedir. AC motorlar için elektronik hız kontrol cihazları genellikle AC giriş akımını doğrultucu diyotlarla DC akıma çevirir ve daha sonra çevirici diyotlar vasıtasıyla bu akımı tekrar AC akıma çevirir. Doğrultucu diyotlar ile çevirici diyotlar arasındaki bağlantı DC-bağ olarak tanımlanmaktadır. DC kontrol cihazının (genellikle invertör olarak isimlendirilir) elektriksel blok şeması aşağıda verilmiştir.

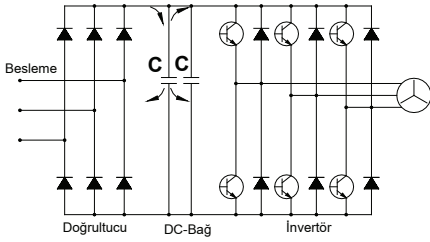

Tam dalga doğrultucuları besleyen üç faz besleme akımı DC-bağ kapasitörlerine iletilir. Kapasitörler voltajdaki dalgalanmaları azaltır ve kısa süreli ağdaki akım kesintilerinde enerji sağlar. Kapasitörlerdeki voltaj kontrolsüzdür ve gelen AC akımın pik akım değerlerine bağlıdır. DC akım tekrar AC akıma, Puls genişliği modülasyonu (PWM) kullanılarak çevrilir. İstenen dalga formu, sabit bir frekansta (Puls frekansında), çıkış transistörlerinin (İzole edilmiş geçit Bipolar transistörleri; IGBT 'ler) açılıp kapatılması ile oluşturulur. IGBT'lerin açma kapama zamanlarının değişimi ile istenen akım oluşturulabilir. Çıkış voltajı bir seri kare dalga pulslardır ve motor sargılarının indüktansı ile sinusoidal bir motor akımı oluşur. Puls genişliği modülasyonu aşağıda gösterilmiştir.

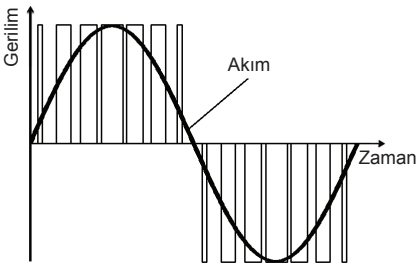

## f- AC Frequency Inverters

An electronic converter is a device which converts Direct Current (DC) to Alternating Current (AC) is known as an inverter. Electronic speed controllers for AC motors usually convert the AC supply to DC using a rectifier, and then convert it back to a variable frequency, variable voltage AC supply using an inverter bridge. The connection between the rectifier and inverter is called the DC link. The block diagram of a speed controller (often called an inverter) is shown below.

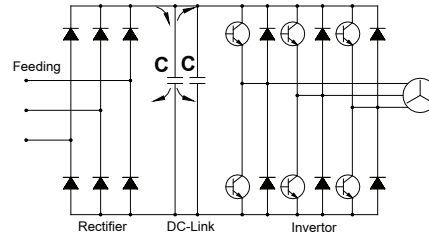

The three phase supply is fed into a full wave rectifier which supplies the DC link capacitors. The capacitors reduce the voltage ripple (especially on single supplies) and supply energy for short mains breaks. The voltage on the capacitors is uncontrolled and depends on the peak AC supply voltage. The DC voltage is converted back to AC using Pulse Width Modulation (PWM). The desired waveform is built up by switching the output transistors (Insulated Gate Bipolar Transistors; IGBTs) on and off at a fixed frequency (the switching frequency). By varying the on and off time of the IGBTs the desired current can be generated. The output voltage is still a series of square wave pulses and the inductance of the motor windings results in a sinusoidal motor current. Pulse Width Modulation is shown in the figure below.

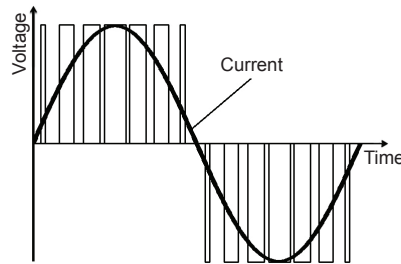

## f- AC Frequenz Umrichter

Ein elektronischer Wandler, der den Gleichstrom (DC) in Wechselstrom (AC) umwandelt, wird als Umrichter bezeichnet. Ein Frequenzumrichter benutzt einen ungesteuerten Eingangsgleichrichter, um die Netzspannung in Gleichspannung umzuwandeln. Diese wird dann in den Zwischenkreiskondensatoren gespeichert. An diesem Gleichspannungszwischenkreis ist ein Wechselrichter angeschlossen. Dieser Wechselrichter erzeugt am Ausgang eine variable Frequenz und eine variable Spannung. Der Anschluss zwischen dem Gleichrichter und dem Wechselrichter nennt man Gleichstromverbindung. Das Blockschaltbild von diesem System wurde unten dargestellt:

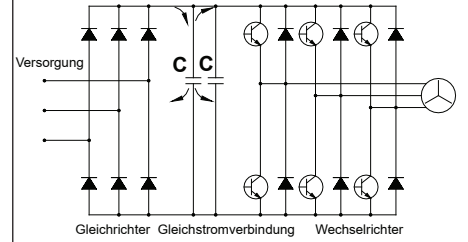

Auch bei dreiphasiger Versorgung wird die gleichrichtete Netzspannung den Zwischenkreiskondensatoren zugeführt. Die Kondensatoren reduzieren die Oberwelligkeit der Spannung (was besonders bei einphasiger Versorgung entscheidend ist) und liefern Energie, die kurze Unterbrechungen der Netzstromversorgung ermöglicht. Die Spannung der Kondensatoren ist vom Spitzenwert der Wechselspannung abhängig. Die Gleichspannung wird im Wechselrichter durch Pulsweitenmodulation (PWM) in Wechselspannung umgewandelt. Die gewünschte Wellenform wird durch Ein- und Ausschalten der Ausgangstransistoren (IGBT's Isolierte Gate Bipolar Transistoren) mit einer festen Frequenz (der Pulsfrequenz) erzeugt. Der gewünschte Strom kann durch die Variation der Ein- und Ausschaltzeit der Ausgangstransistoren generiert werden. Die Ausgangsspannung ist dadurch eine Reihe von Spannungsimpulsen, die in Verbindung mit der Induktivität der Motorspulen zu einem sinusförmigen Motorstrom führt. Die Pulsweitenmodulation wird wie folgt dargestellt

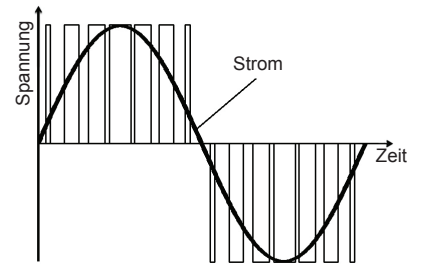



# Genel Bilgiler

## General Information

### Einführung



#### DC MOTORLAR

##### a- Genel Özellikler

DC motorlar, elektronik parçalardaki gelişmeler nedeni ile yeni uygulama alanları bulmuştur. Daha önce çok pahalı olan ve ekonomik olmayan kontrol sistemlerinin yerini ucuz ve kompakt güç kontrol üniteleri almıştır. Yol vermenin kontrol altına alınabildiği, tork ve akım izlenebilirliği, aşırı yüklenmeye karşı elektronik koruma sağlanabilmesi ve daha birçok pahalı olmayan uygulamalar DC motorlarını cazip kılmaya başlamıştır.

##### b- DC Motorların Çalışma İlkeleri

DC motorlar için DC çıkış veren bir doğrultucuya ihtiyaç vardır. Motor armatür sargıları, alan sargıları, komutasyon sargıları ve kompanse sargılar olmak üzere rotorda ve statorda bulunan sargılardan oluşur. Rotora voltaj ve akım karbon fırçalar ve komutator sargılarla ulaştırılır. Bu karbon fırçalar aşındığından DC motorlar belirli periyotlarla bakıma alınmalıdır. İyi kontrol edilebilir özelliklerinden dolayı DC motorlar otomasyon teknolojisinde sıkça kullanılmaktadır.

##### c- DC Motor Çeşitleri

Temel olarak Şönt (Shunt) ve seri sargılı DC motorlar bulunmaktadır. Bu sargıların çeşidine göre moment eğrisi değişmektedir.

##### d- DC Motorlarda Hız Kontrolü

Bu motorlarda devir değişimi DC voltajın değiştirilmesi ile yapılır. Şönt sarımlı DC motorların sıfır yük ile maximum yük arasındaki davranışı AC motorlara benzer. Devir artan yüklerle beraber düşer. Bu devir farkı ufak güçlü motorlarda büyük, büyük güçlü motorlarda ise ufaktır. Fakat bu hız farkı DC doğrultucu cihazda armatür voltajı ( $I \times R$ ) ile oynanarak kompanse edilebilir. Hassas hız kontrol gereksinimi olduğunda, tako jeneratörler kullanılabilir. DC motorların gücü aşağıdaki formülden hesaplanır;

$$P_g = U \times I = \frac{P_c}{\eta}$$

$P_g$  : Giriş gücü W  
 $P_c$  : Çıkış gücü W  
 $U$  : Armatür gerilimi V  
 $I$  : Armatür akımı A  
 $\eta$  : Motor verimi

#### DC MOTORS

##### a- General Specifications of DC Motors

*DC drive systems have found new possible applications with the development of the electronic components sector. What was previously extremely expensive and in some cases not economically feasible is nowadays realized by miniaturized power converter technology. Additional functions such as guided startup after a predetermined time, torque and current monitoring with electronic protection against overloading, and many inexpensive special applications have made DC drive systems more attractive.*

##### b- Operating principles of the DC Motors

*The DC motor requires, a converter with DC output. The motor includes windings, such as armature, field, commutation and compensation windings, which are arranged in the stator as well as on rotor. Voltage and current are supplied to the rotor via the carbon brushes and the commutator. The carbon brushes are wearing parts therefore a DC motor requires maintenance at service intervals. While its good control properties, the DC motor is an essential item in automation technology.*

##### c- Types of DC Motors

*Depending on the wiring of the exciting winding or field winding, two basically different variants are regards torque speed characteristics may be distinguished.*

##### d- Speed Control of DC motors

*In DC motors the speed is adjusted by altering the DC voltage. DC shunt wounded motors behave similar to three phase induction motors between no load operation and maximum load. The speed drops with increasing loading of the motor. This difference is greater in small motors and smaller in larger motors. The speed difference can be compensated in the DC converter device by adjusting ( $I \times R$ ). If great control accuracy is required, a speed control with measurement of the actual values by a tachogenerator can be used. The power of DC motor;*

$$P_g = U \times I = \frac{P_c}{\eta}$$

$P_g$  : Input Power W  
 $P_c$  : Output Power W  
 $U$  : Armature Voltage V  
 $I$  : Armature Current A  
 $\eta$  : Motor efficiency

#### DC MOTOREN

##### a- Eigenschaften von DC Motoren

Mit den Entwicklungen bei elektronischen Komponenten haben DC Motoren neue Anwendungsbereiche gefunden. Regelungssysteme, die früher sehr teuer und im manchen Anwendungsfällen ungünstig waren, sind jetzt kompakt und günstig. Bei den DC Motoren ist kontrolliertes Anlauf, Moment- und Stromüberwachung mit Überlastschutz möglich. Es gibt viele günstige Sonderanwendungen für diese Motoren. Wegen oben genannten Eigenschaften werden die DC Motoren immer mehr bei unterschiedlichen Anwendungen benutzt.

##### b- Funktionsprinzip der DC Motoren

Bei DC Motoren ist eine Kommutatorwicklung im Rotor angeordnet, während der magnetische Fluss vom Stator erzeugt wird. Dies kann wiederum mittels einer Erregerwicklung oder durch Permanentmagnete geschehen. Wie bei der Synchronmaschine wird durch das Erregerfeld in der Ankerwicklung eine Wechselfeldspannung, die bei der Gleichstrommaschine jedoch durch den mechanischen Kommutator und die darauf schleifenden Bürsten in eine Gleichspannung umgeformt wird, induziert.

##### c- Arten von DC Motoren

Es gibt zwei verschiedene Wicklungen, nämlich Shunt- und Serial-Wicklung. Das Drehmoment-Drehzahl-Verhältnis ist für beide Wicklungen unterschiedlich.

##### d- Drehzahl Kontrolle für DC Motoren

Drehzahl von DC Motoren kann man mit Steuerung der DC Spannung ändern. DC Motoren mit Shunt Wicklungen ist ähnlich zu drei phasen AC Motoren zwischen maximalen Last und ohne Last. Drehzahl wird mit der Last reduziert. Mit kleineren Motoren wird dieser Differenz höher mit größeren Motoren kleiner. Der Drehzahlunterschied kann geregelt werden mit ( $I \times R$ ) Veränderung. Wenn eine genaue Kontrolle gebraucht, soll ein Tachogenerator benutzt werden. Leistung des DC Motors;

$$P_g = U \times I = \frac{P_c}{\eta}$$

$P_g$  : Eingangsleistung W  
 $P_c$  : Ausgangsleistung W  
 $U$  : Ankerspannung V  
 $I$  : Ankerstrom A  
 $\eta$  : Wirkungsgrad des Motors



# Genel Bilgiler

## General Information

### Einführung



#### Elektromanyetik Frenler

Bu tip frenlerin iki sürtünme yüzeyi vardır. Fren torku, voltaj uygulanmadığı zaman yayların kuvveti ile oluşturulur. Fren elektromanyetik alanın oluşumu ile serbest kalır. Bobinin beslenmesi ile mıknatıslanan balata baskı pulu, elektromıknatısa doğru çekilir. Bu hareket yayları baskı altına alır ve rotor mili üzerine takılan çoklu kama üzerinde aksiyal yönde serbest hareket edebilen balata serbest kalır. Akım kesildiğinde yayların baskısıyla, balata baskı pulu fren balatasına doğru itilir ve bu hareket rotoru frenler.

#### Fren Çeşitleri

##### a) Soğutmasız tip frenler

Motor fanı çıkarılıp motor kapağı arkasına akuple edilerek kullanılan frenler; genellikle sıkça açılıp kapanmayan ve kısa zaman aralıklarında çalışan sistemlerde tercih edilir.

##### b) Soğutmalı tip frenler

Motor fanı çıkarılıp motor kapağı arkasına akuple edilen ve motorun mili uzatılarak fren ve motorun arkasına alınan fan sayesinde daimi bir hava sirkülasyonu sağlanarak kullanılan frenlerdir. Genellikle uzun süreli çalışan ve kapalı mekanlarda kullanılan sistemlerde tercih edilirler.

##### c) Manuel kol sistemli frenler

Çalışma sistemi olarak her iki fren tipinde de kullanılabilir (soğutmalı veya soğutmasız). Özel durumlarda (elektrik kesilmesi; mekanik problemler) üzerinde bulunan bir kol vasıtası ile sistemi yay baskısından kurtararak serbest kalmasını sağlayan frenlerdir. Genellikle manuel olarak sistemin açılması gereken yerlerde (otomatik giriş kapıları, dış cepe boyama asansörleri v.b.) tercih edilir.

#### Fren çalışma voltajları

Elektromanyetik frenler 230V AC veya 400V AC beslemeli olarak sipariş edilebilir. Frenler DC fren olmaları nedeni ile besleme ile fren bobini arasında fren tipine bağlı olarak, yarım dalga, tam dalga doğrultucular veya trafolar kullanılır. Özel olarak belirtilmedikçe 230V beslemeli ve yarım dalga doğrultuculu frenler kullanılmaktadır. Özel durumlar için YILMAZ Redüktöre danışınız.

##### a) 230V AC ile beslenen frenler

Motor klemens kutusundan alınan 230V'luk AC besleme fren tipine bağlı olarak yarım dalga veya tam dalga doğrultucu ile fren bobininin voltajına düşürülür. Fren bobin DC voltajı etiketi üzerinde belirtilmiştir.

##### b) 400V AC ile beslenen DC frenler

Motor klemens kutusundan alınan 400V'luk AC besleme, yarım dalga doğrultucu ile fren bobininin voltajına düşürülür. Fren bobininin DC voltajı etiket üzerinde belirtilmiştir.

##### c) 24V DC Frenler

Kullanılan fren momentinin büyüklüğüne göre besleme transformatörü seçilir. Şebekeden veya motorun klemens kutusundan alınan besleme voltajı transformatörde 29 V'a çevrilen gerilim tam dalga doğrultuculardan geçerek 24V DC'ye çevrilir ve fren bobini beslenir.

#### Electromagnetic Brakes

*This type of brakes has two friction surfaces. Brake torque is generated by springs when no voltage is applied. The brake is electromagnetically released. On exciting the electromagnet means of the current, the armature plate is pulled towards the electromagnet itself, thrust loading the pressure spring and enabling the friction disc which is axially movable on the key, to turn freely. When current fails, the pressured springs drive the armature plate towards the disc, thus braking the motor shaft.*

#### Brake Types

##### a) Brakes without cooling

*This type of brakes are assembled on the back cover of the electric motor. There is no fan on the backside. This brake type is mostly preferred in short working times and short working cycles.*

##### b) Fan cooled brakes

*This type of brakes are assembled on the back cover of electric motor by removing the electric motor fan. A fan is coupled to the backside of the brake by extending the rotor shaft of the electric motor. Fan cooled brakes are preferred in long working times and closed places without airflow.*

##### c) Brakes with hand release

*This brakes can be released by help of an arm. It can be applied to both of the above mentioned brakes and used in special cases (fail of electric current, mechanical problems etc.) These brakes are mostly preferred if operation (releasing) without a current is needed (automatic controlled doors, gates, building wall painting elevators etc.).*

#### Working Voltages

*Electromagnetic brakes can be ordered with 230V AC or 400V AC supply voltage. The coil of brakes needs DC voltage and therefore depending on brake type a half wave, a full wave rectifier or transformer should be used between supply and coil voltage. As standard the brakes will be delivered with 230V supply voltage and half wave rectifier, if there is no special request. For special cases please contact YILMAZ Redüktör.*

##### a) Brakes with 230V supply voltage

*230V AC supply voltage from the motor terminal box will be reduced to the coil voltage depending on the brake type with half-wave or full-wave rectifier. DC brake coil voltage is indicated on the label.*

##### b) Brakes with 400V supply voltage

*400V AC supply voltage from the motor terminal box will be reduced to the coil voltage with half-wave rectifier. DC brake coil voltage indicated on the label.*

##### c) 24V DC Brakes

*The transformer's size is selected according to value of brake torque. The current is taken from the electric motor terminal box or from the electric panel and is transformed to 29V DC current. This current is transferred to 24V DC current with full-wave rectifier and supplies brake coil.*

#### Elektromagnetische Bremsen

Die Bremse hat zwei Reibflächen und arbeitet nach dem Ruhestromprinzip. Im stromlosen Zustand wird das Bremsmoment durch den Druck der Feder erzeugt, während die Bremse beim Betrieb elektromagnetisch losgelassen wird. Durch die Erregung der Elektromagneten wird die Ankerscheibe zu den Elektromagneten gezogen und die Feder zusammengedrückt. Dadurch kann sich die Bremsscheibe, die axial beweglich auf dem Mitnehmer angeordnet ist, frei drehen. Wird der Strom unterbrochen, drücken die Feder die Ankerscheibe gegen die Bremsscheibe und halten die Motorwelle an.

#### Bremsearten:

##### a) Bremsen ohne Kühlung

Diese Bremsen sind für Kurzlaufzeiten geeignet. Die Lüfterhaube und Lüfter des Motors ist ausgebaut und die Bremse ist an dem Ende der Motorwelle befestigt.

##### b) Bremsen mit Kühlung

Diese Bremsen sind für lange Laufzeiten und kleine, abgedeckte Räume geeignet. Durch die Verlängerung der Motorwelle wurde Lüfter hinter dem Bremse und dem Motor verbunden. Somit wurde eine konstante Lüftung ermöglicht.

##### c) Bremsen mit Hebelarm

Diese Bremsenart kann mit oder ohne Kühlung verwendet werden. Diese Bremsen sind bei der speziellen Fälle, wie keine Spannung an der Leitung, mechanische Probleme usw., anwendbar. Die Bremse wird mit einem Hebelarm manuell betätigt. Diese Bremsen werden am meisten an den Stellen, wo die Lüftung ohne Spannung erfolgen soll, benutzt (automatische Türe, Wandaufzüge).

#### Betriebsspannungen

Elektromagnetische Bremsen können mit 230V AC oder 400V AC Versorgungsspannung bestellt werden. Die Wicklungen der Bremsen brauchen Gleichspannung und deswegen abhängig von Bremsenart zwischen Versorgungsspannung und Wicklungsspannung soll Halbwellen-, Vollweggleichrichter oder Transformator verwendet werden. Als Standard die Bremsen werden mit 230V Versorgungsspannung und Halbwellengleichrichter geliefert.

##### a) Bremsen mit 230V Versorgungsspannung

230V AC Versorgungsspannung von Klemmenkasten wird auf die Wicklungsspannung abhängig von der Bremsentyp mit Halbwellen-oder Vollweggleichrichter reduziert. Wicklungsspannung ist auf dem Etikett angegeben.

##### b) Bremsen mit 400V Versorgungsspannung

400V AC Versorgungsspannung von Klemmenkasten wird auf die Wicklungsspannung mit Halbwellengleichrichter reduziert. Wicklungsspannung ist auf dem Etikett angegeben.

##### c) 24 V DC Bremsen

Die Spannung wird von den Klemmenkasten des Motors oder Elektrikschrank entnommen. Diese Spannung wird zuerst mittels Transformator zu 24 V reduziert. Danach wird diese Spannung mit Hilfe von Gleichrichter zu Gleichstromspannung umgewandelt. Die Größe des Transformators ist abhängig von der Größe des Bremsmoments.



# Genel Bilgiler

## General Information

### Einführung



#### d) Şok ikazlı trafolar

Büyük güçteki ve momentteki frenlerin manyetik doyuma ulaşmaları uzun zaman alır. Şok ikazlı trafolar frenin yay baskısını yenmede gecikmesini engellemek için kullanılır ve zaman rölesi yardımı ile çok kısa bir süre normal besleme voltajının iki katı ile (48V DC) beslenip sistemin ani açılmasını sağlar. Bu sayede gecikmeli açılmada ortaya çıkacak sürtünmeyi engellemeye yarayan bir trafo şeklindedir.

#### Fren bağlantı şekli

##### a) Gecikmeli frenleme

Genellikle sistemin yavaş ve kaydırılarak durması gereken yerlerde tercih edilen bağlantı şeklindedir. Vinç yürütme motorlarındaki sarsıntıyı önlemek için gecikmeli bağlantı şekli kullanılır. Frenler fabrika çıkışında gecikmeli bağlantıya uygun ayarlanır.

##### b) Ani frenleme

Genellikle sistemin enerjisi kesildiği anda ani olarak durdurulması gereken sistemlerde kullanılan bağlantı şeklindedir. Vinç kaldırma sistemleri, asansör motorlarında kullanılan bağlantı şeklindedir.

#### d) Shock voltage supply transformer

Brakes which consist of high power and torques take long time to get in electromagnetic field. Shock voltage supply transformers with time relay are aiming to overcome spring pressure delaying for brakes. Also this transformers provide to open system suddenly by feeding double(48V DC) voltage in a short time and preventing to frictional losses occurring in delayed opening.

#### Connection Types

##### a) Delayed Braking

Generally this type of connection uses in slow and sliding brake intended systems. Delayed connection type using to prevent shock loadings in crane driving systems. Brakes are setting up to delayed connection if any other types are not specified by customer

##### b) Sudden Braking

This type of connections are mostly used in systems when short braking times are needed. The braking torque will be produced as soon as the current fails. These brakes are mostly used in hoisting of lifting units and elevators.

#### d) Trafos mit Schock-Spannung

Diese Transformatoren werden bei großen Bremsen mit hohen Momenten verwendet. Da die große Bremsen eine lange Zeit braucht, um die erforderliche magnetische Feld zu erzeugen, wird an der Bremse kurz 48V Gleichstromspannung angelegt, um die Zeit zur Bildung von magnetischem Feld zu kürzen. Dies ermöglicht kürzere Reibungszeiten beim Start.

#### Schaltungsarten:

##### a) Verspätetes Bremsen

Diese Schaltung wird benutzt, wenn ein langsames und gleitendes Bremsen erforderlich ist. Am meisten wird es bei Fahrtriebmotoren von Aufzügen verwendet. Wenn keine Angabe bei der Bestellung gegeben wird, werden die Bremsen mit verspäteter Schaltung geliefert.

##### b) Schnelles Bremsen:

Allgemein verwendet man diese Schaltung bei Bedarf an plötzlichen Bremsen in dem Augenblick, in dem das System keine Energie mehr erhält. Diese Schaltungsart wird meist bei Kräne und Motoren von Aufzüge verwendet.

Geçikmeli Frenleme / Delayed Running Brake / Verspätete Bremsung  
(230 V)

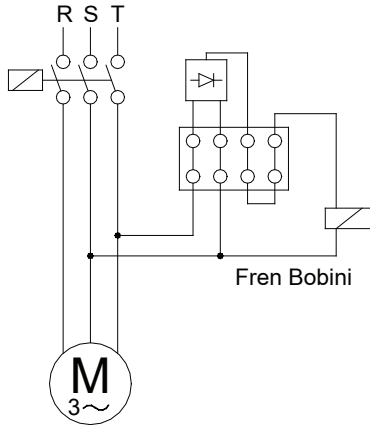

Ani Frenleme / Sudden Brake / Plötzliche Bremsung  
(230 V)

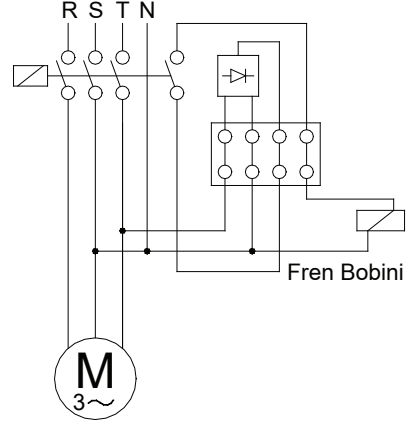

Geçikmeli Frenleme / Delayed Running Brake / Verspätete Bremsung  
(24 V)

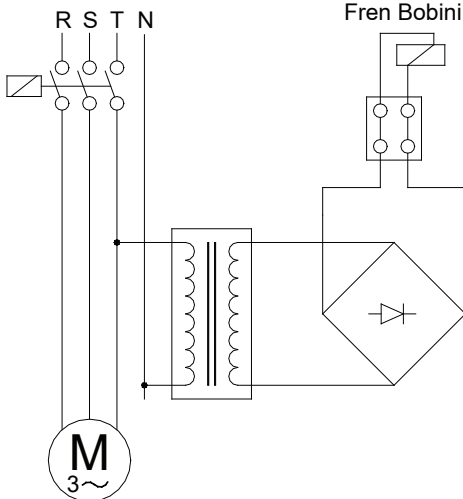

Ani Frenleme / Sudden Brake / Plötzliche Bremsung  
(24 V)

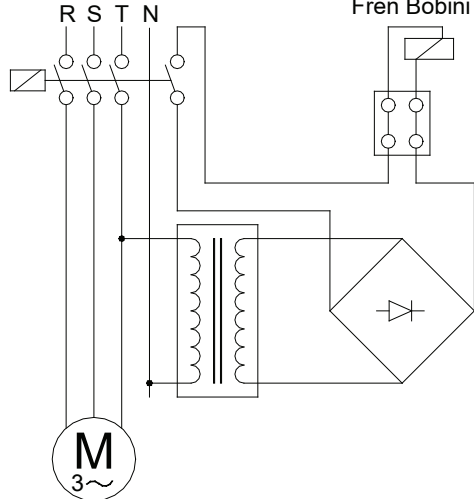



# Genel Bilgiler

## General Information

### Einführung



#### Fren Seçimi:

Doğru bir fren seçimi için aşağıdaki parametreler bilinmelidir.

- $I_{tot}$  [kg.m<sup>2</sup>] : Motor miline indirgenmiş toplam atalet momenti
- $n_0$  [d/dak] : Maksimum motor devir sayısı
- $t_f$  [s] : İstenilen en uzun frenleme zamanı
- $c_t$  : Anahtarın devreye girme zamanı katsayısı (ortalama 0,995).
- $M_L$  [Nm] : Sistemin statik tork ihtiyacı.
- $C_s$  : Emniyet katsayısı ( $C_s \geq 2$  olmalı)

Gerekli fren momenti aşağıdaki şekilde hesaplanır:

a)  $M_L$  Statik yük torku, motor dönüş yönünde (motorun dönüşüne yardımcı olarak, yükün indirilmesi veya hızlandırıcı sabit yük momenti hali):

$$M_{fc} = \frac{(2 \pi \times n_0 \div 60) \times I_{tot}}{t_f \times C_t} + M_L$$

b)  $M_L$  Statik yük torku, motor aksi dönüş yönünde (motorun dönüşüne engel olarak, yükün yukarı kaldırılması veya frenleyici sabit yük/direnç momenti hali):

$$M_{fc} = \frac{(2 \pi \times n_0 \div 60) \times I_{tot}}{t_f \times C_t} - M_L$$

Yukarıda bulunan sonuç  $C_s$  katsayısı ile çarpılarak ( $C_s \geq 2$ ), fren momenti seçilir;

$$M_f = M_{fc} \times C_s$$

#### Yaklaşım Yolu ile Fren Seçimi:

Eğer yalnızca motorun gücü ve en yüksek devri biliniyor ise :

W [Watt]: Motorun nominal gücü

$$M_f = \frac{W}{\frac{2\pi \times n_0}{60}} \times C_s \quad (C_s \geq 2)$$

#### Brake Selection:

To select a brake correctly the following data are necessary;

- $I_{tot}$  [kg . m<sup>2</sup>] : The total inertia of rotating parts reduced at the motor shaft
- $n_0$  [rpm] : Maximum motor speed.
- $t_f$  [s] : The maximum admitted time of the braking.
- $c_t$  : Coefficient of switch on time (average 0,995).
- $M_L$  [Nm] : Required static torque of system.
- $C_s$  : Safety coefficient ( $C_s \geq 2$ )

The necessary braking torque calculates below;

a) The static load torque  $M_L$ , same direction of motor rotation (Descent of a load or steady resisting torque which favours the rotation of the motor)

$$M_{fc} = \frac{(2 \pi \times n_0 \div 60) \times I_{tot}}{t_f \times C_t} + M_L$$

b) The static load torque  $M_L$ , opposes the rotation of the motor (Lifting of a load or steady resisting torque which opposes the rotation of the motor)

$$M_{fc} = \frac{(2 \pi \times n_0 \div 60) \times I_{tot}}{t_f \times C_t} - M_L$$

The necessary braking torque will result from the following equation using  $C_s$  ( $C_s \geq 2$ );

$$M_f = M_{fc} \times C_s$$

#### Approximated Brake Selection

Its only the motor power and its maximum speed are known:

W [Watt]: Motor Nominal Power

$$M_f = \frac{W}{\frac{2\pi \times n_0}{60}} \times C_s \quad (C_s \geq 2)$$

#### Bremswahl:

Um die richtige Bremse auszuwählen, braucht man unten aufgelistete Variablen;

- $I_{tot}$  [kg . m<sup>2</sup>] : Die Gesamtträgheit der rotierenden Teile (siehe Anwendungsbeispiele)
- $n_0$  [U/min] : Die höchste Drehzahl des Motors
- $t_f$  [s] : Die längste zulässige Bremszeit
- $c_t$  : Reduktionskoeffizient der Tätigkeitszeit (gemittelt 0,995).
- $M_L$  [Nm] : Vom system benötigtes, statisches Drehmoment.
- $C_s$  : Sicherheitskoeffizient ( $C_s \geq 2$ )

Die benötigte Bremskraft wird wie folgt berechnet:

a) konstantes Belastungsmoment  $M_L$ , das die Motordrehung fördert (konstante Erhöhung der Motorgeschwindigkeit oder Herunterlassen der Last)

$$M_{fc} = \frac{(2 \pi \times n_0 \div 60) \times I_{tot}}{t_f \times C_t} + M_L$$

b) konstantes Belastungsmoment  $M_L$ , das sich entgegen der Motordrehung widersetzt (konstante Verminderung der Motorgeschwindigkeit oder Aufheben der Last)

$$M_{fc} = \frac{(2 \pi \times n_0 \div 60) \times I_{tot}}{t_f \times C_t} - M_L$$

Wenn die Bremskraft mit dem Sicherheitskoeffizient  $C_s$  ( $C_s \geq 2$ ) multipliziert wird, erhält man die erforderliche Bremskraft;

$$M_f = M_{fc} \times C_s$$

#### Abschätzung zur Bremswahl

Wenn man nur die Motorleistung und die höchste Drehzahl kennt, kann die Bremskraft mit der folgenden Formel annähernd berechnet werden: W [Watt] : Nennleistung des Motors

$$M_f = \frac{W}{\frac{2\pi \times n_0}{60}} \times C_s \quad (C_s \geq 2)$$

#### Standart Frener / Standard Brakes / Standart Bremsen

<b>Fren statik momenti [Nm]</b> Brake Static Torque [Nm] Statische Bremskraft [Nm]	4,5	8	12	16	35	60	80	150	200
<b>Fren Dinamik Momenti [Nm]</b> Brake Dynamic Torque [Nm] Dynamische Bremskraft [Nm]	3,6	6,4	9,6	12,8	28	48	64	120	160
<b>Maksimum Motor Hızı [d/dak]</b> Maximum Motor Speed [rpm] Maximale Motordrehzahl [U/min]	3000	3000	3000	3000	3000	3000	3000	1500	1500
<b>Giriş Gücü [W]</b> Input Power [W] Antriebsleistung [W]	15	20	25	30	45	50	55	60	65

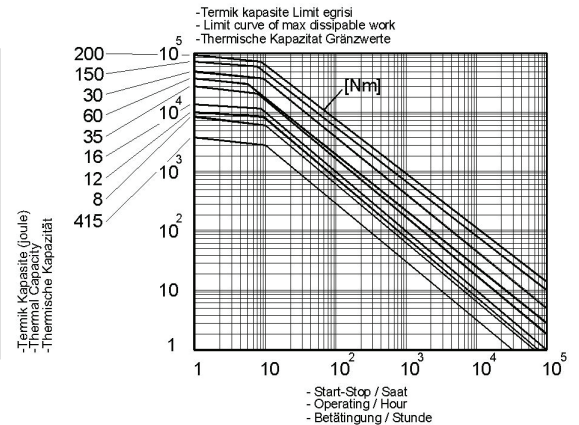



# Genel Bilgiler

## General Information

### Einführung



#### Frenin Termik Kapasitesi

Yukarıdaki seçime ek olarak frenin termik kapasitesinin kontrol edilmesi gerekir. L (joule) olarak gerekli soğutma işi aşağıdaki formüller ile hesaplanır ve "Termik kapasite limit eğrisi" kullanılarak eğrinin altında kalıp kalmadığı kontrol edilir.

a)  $M_L$  Statik yük torku motor dönüş yönünde (motorun dönüşüne yardımcı olarak, yükün indirilmesi hali)

$$L = \frac{I_{tot} \times (2\pi \times n_0 \div 60)^2}{2} \times \left( \frac{M_f}{M_f - M_L} \right)$$

b)  $M_L$  Statik yük torku motor aksi dönüş yönünde (motorun dönüşüne engel olarak, yükün kaldırılması hali):

$$L = \frac{I_{tot} \times (2\pi \times n_0 \div 60)^2}{2} \times \frac{M_f}{M_f + M_L}$$

c)  $M_L$  Statik yük torku sabit, motor yönünde veya aksi yönde (kaldırma ve indirme harici hızlandırıcı veya frenleyici sabit bir yük momenti hali).

$$L = \frac{I_{tot} \times (2\pi \times n_0 \div 60)^2}{2}$$

#### Fren Hava Boşluğunun Ayarı:

Frenin sürekli aynı performansın alınabilmesi için, fren balatasının aşınmasına bağlı olarak, fren hava boşluğu belirli zaman aralıklarında yeniden ayarlanmalıdır. Fren hava boşluğu ayar zaman aralığı ve ayarın yapılması için firmamıza danışınız.

#### Fren Seçim Örneği:

İstenilen en uzun frenleme zamanı: 0,5 sn.  
Motor devri: 1400 d/dak  
Motora indirgenmiş toplam atalet momenti: 0,08 kgm<sup>2</sup>

Gerekli çalışma momenti: 50 Nm

Yük Durumu: Yük motor dönüş yönü ile aynı (Vinçten yük indirmesi: Saatte dur-kalk sayısı:30)

$$M_{fc} = \frac{(2\pi \times 1400 \div 60)}{0,5 \times 0,995} + 50 = 73,6 \text{ Nm}$$

$$M_f = 73,6 \times 2 = 147,2 \text{ Nm}$$

Standart frenler tablosundan 150 Nm lik fren seçilebilir.

Gerekli termik kapasite;

$$L = \frac{0,08 \times (2\pi \times 1400 \div 60)^2}{2} \times \left( \frac{147,2}{147,2 - 50} \right)$$

=1302,0 < 18000 Joule (150 Nm eğrisinden)  
150 Nm lik fren uygun görülüyor.

#### The Thermal Capacity of Brake

The thermal capacity of the brake must also be checked after the above mentioned calculations heat dissipation energy L (joule) can be calculated from the following equation and must be checked if the result is under the limit curve shown on "Limit curve of may dissipated work".

a) The static load torque  $M_L$ , favours the rotation of the motor (Descent of a load which favours the rotation of the motor)

$$L = \frac{I_{tot} \times (2\pi \times n_0 \div 60)^2}{2} \times \left( \frac{M_f}{M_f - M_L} \right)$$

b) The static load torque  $M_L$ , opposes the rotation of the motor (Lifting of a load which opposes the rotation of the motor)

$$L = \frac{I_{tot} \times (2\pi \times n_0 \div 60)^2}{2} \times \frac{M_f}{M_f + M_L}$$

c) The static load torque  $M_L$ , is constant and opposes or favours the rotation of the motor (except lifting of a load)

$$L = \frac{I_{tot} \times (2\pi \times n_0 \div 60)^2}{2}$$

#### Adjustment of the air-gap:

In order to obtain the same performance from the brake during its lifetime, the air-gap of the brake must be re-adjusted after a limited time of operation. For the air-gap and the time interval of the adjustment please contact us.

#### Selection Example:

The maximum admitted time for braking 0,5 s  
Motor speed: 1400 rpm  
Total inertia reduced at motor shaft: 0,08 kgm<sup>2</sup>

Required operating torque: 50 Nm

Nature of load: Load direction is same as motor direction (Unloading process: Start-stop time per hour :30)

$$M_{fc} = \frac{(2\pi \times 1400 \div 60)}{0,5 \times 0,995} + 50 = 73,6 \text{ Nm}$$

$$M_f = 73,6 \times 2 = 147,2 \text{ Nm}$$

From the brake selection table a standard brake of 150 Nm is selected.

Necessary thermal capacity

$$L = \frac{0,08 \times (2\pi \times 1400 \div 60)^2}{2} \times \left( \frac{147,2}{147,2 - 50} \right)$$

=1302,0 < 18000 Joule (from 150 Nm curve)  
The selected brake with 150 Nm is suitable.

#### Thermische Kapazität der Bremsen

Nach den oben genannten Berechnungen muss die thermische Kapazität überprüft werden. Die Wärme, d.h. die gebrauchte Energie L, werden mit den folgenden Formeln berechnet. Die gerechnete Werte von Kapazitäten sollen unter dem Grenzkurve "Thermische Kapazität Grenzwerte" der gewählten Bremse liegen.

a) Konstantes Belastungsmoment  $M_L$ , das die Motordrehung fördert (Herunterlassen der Last)

$$L = \frac{I_{tot} \times (2\pi \times n_0 \div 60)^2}{2} \times \left( \frac{M_f}{M_f - M_L} \right)$$

b) Konstantes Belastungsmoment  $M_L$ , das sich entgegen der Motordrehung widersetzt (Aufheben der Last)

$$L = \frac{I_{tot} \times (2\pi \times n_0 \div 60)^2}{2} \times \frac{M_f}{M_f + M_L}$$

c) Konstantes Belastungsmoment  $M_L$ , das sich gegen der Motorbewegung widersetzt oder die Motorrotation fördert (Konstante Verminderung oder Erhöhung der Motorgeschwindigkeit, kein Herunterlassen oder Aufheben der Last)

$$L = \frac{I_{tot} \times (2\pi \times n_0 \div 60)^2}{2}$$

#### Einstellung des Luftspaltes:

Um eine immer konstant bleibende Bremsfähigkeit zu erhalten, muss das Luftspalt nach einer bestimmten Arbeitszeit neu eingestellt werden. Für die Bestimmung des Luftspaltes und die Einstellzeiten bitten wir Sie um Rückfrage.

#### Beispiel für eine Auswahl:

Die höchste zulässige Bremszeit: 0,5 s  
Motordrehzahl: 1400 U/min  
Gesamtträgheit der rotierenden Teile: 0,08 kgm<sup>2</sup>

Das auf das System wirkende Drehmoment: 50 Nm

Belastungsart: Drehmoment, das die Motorrotation fördert (Herunterlassen der Last)  
Betätigungen pro Stunde:30

$$M_{fc} = \frac{(2\pi \times 1400 \div 60)}{0,5 \times 0,995} + 50 = 73,6 \text{ Nm}$$

$$M_f = 73,6 \times 2 = 147,2 \text{ Nm}$$

Eine Bremse von 150 Nm kann man auswählen.

Die thermische Kapazität;

$$L = \frac{0,08 \times (2\pi \times 1400 \div 60)^2}{2} \times \left( \frac{147,2}{147,2 - 50} \right)$$

=1302,0 < 18000 Joule (von 150 Nm Kurve) Die ausgewählte 150 Nm Bremse ist ausreichend.

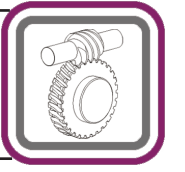

# Güç ve Devir Tabloları

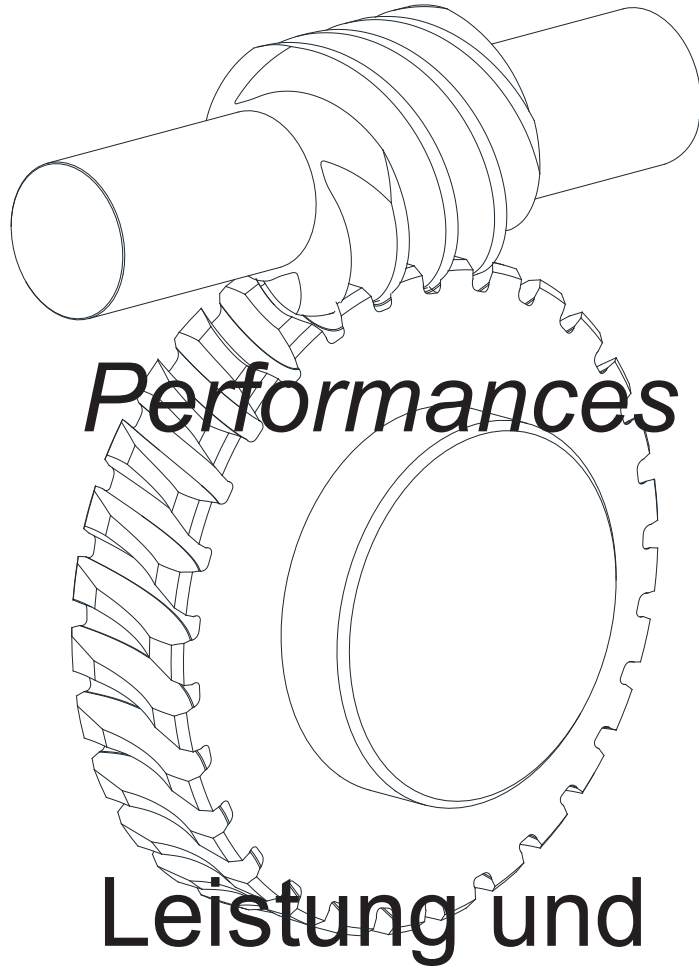

## Leistung und Drehzahlübersicht



# E Serisi Motorlu Güç Devir Sayfaları

## E Series Geared Motors Performance Tables

### E Serien Getriebemotoren Leistung und Drehzahlübersicht

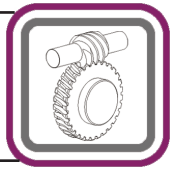

Güç	Çıkış Devri	Çıkış Momenti	Çıkış Gücü	Çevrim Oranı	Güv. Rad. Yük Çıkış	Servis Faktörü	Tipi	Anma Akımı	Ağırlık	Ölçü Sayfası	Fiyat Kodu
Power	Output Speeds	Output Torque	Output Power	Ratio	Per.O. Loads (Output)	Service Factors	Type	Rated Current	Weight	Dim. Page	Price Ref.
Leistung P <sub>g</sub> [kW] P <sub>g</sub> [HP]	Abtriebswelle Drehzahlen n <sub>2</sub> [r.p.m]	Abtriebswelle Drehmomente M <sub>2</sub> [Nm]	Abtriebswelle Leistung P2 [kW]	Übersetzung i	Zul.Querkräfte (Abtrieb) F <sub>qam</sub> [N]	Betriebsfaktor f <sub>s</sub>	Typ	Nennstrom [A]	Gewicht [kg]	Maße Seite	Preis No.
0,06 0,08	0,28 0,38 0,46 0,60 0,80 0,97 1,1 1,4 1,7 1,9 2,3 2,8 3,3 4,6	201 150 175 144 107 95 120 101 93 86 67 65 57 45	0,01 0,01 0,01 0,01 0,01 0,01 0,01 0,02 0,02 0,02 0,02 0,02 0,02 0,02	4920 3660 3060 2340 1740 1450 1218 986 841 725 609 493 420,5 304,5	6200 6200 6200 6200 6200 6200 6200 6200 6200 6200 6200 6200 6200 6200	0,3 0,5 0,5 0,7 1,0 1,0 1,2 1,2 1,3 1,5 1,8 2,0 2,2 2,7	EV063-E030-56/4a	0,25	10,3	102	E001
	0,28 0,38 0,47 0,61 0,80 1,0 1,1 1,4 1,6 1,9 2,3 2,8 3,3 3,9 4,6 5,7 6,7 8,0 10	204 152 160 131 107 95 85 105 82 74 65 71 65 59 47 45 40 36 31	0,01 0,01 0,01 0,01 0,01 0,01 0,01 0,02 0,01 0,02 0,02 0,02 0,02 0,02 0,02 0,03 0,03 0,03 0,03	4980 3720 3000 2280 1740 1450 1218 986 870 725 609 493 421 363 305 247 210 174 138	4800 4800 4800 4800 4800 4800 4800 4800 4800 4800 4800 4800 4800 4800 4800 4800 4800 4800 4800	0,3 0,3 0,3 0,5 0,5 0,7 0,7 0,7 1,0 1,0 1,2 1,5 1,5 1,5 1,8 2,0 2,2 2,7 2,8	EV050-E030-56/4a	0,25	8	101	E002
	0,38 0,47 0,56 0,73 0,88 1,0 1,3 1,5 1,8 2,1 2,6 2,9 3,5 4,2 5,1 6,0 7,0 8,3 10 12 17	213 172 144 110 105 94 76 102 95 83 69 63 56 50 42 39 41 33 31 28 21	0,01 0,01 0,01 0,01 0,01 0,01 0,01 0,02 0,02 0,02 0,02 0,02 0,02 0,02 0,02 0,02 0,03 0,03 0,03 0,04 0,04	3720 3000 2520 1920 1600 1344 1088 960 800 672 544 480 400 336 272 232 200 168 136 116 84	3400 3400	0,2 0,2 0,2 0,2 0,3 0,3 0,3 0,3 0,7 0,7 0,7 1,0 1,0 1,2 1,5 1,7 1,8 2,2 2,0 2,3 2,8	EV040-E030-56/4a	0,25	6,2	100	E003



# E Serisi Motorlu Güç Devir Sayfaları

## E Series Geared Motors Performance Tables

### E Serien Getriebemotoren Leistung und Drehzahlübersicht

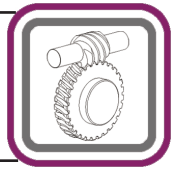

Güç	Çıkış Devri	Çıkış Momenti	Çıkış Gücü	Çevrim Oranı	Güv. Rad. Yük Çıkış	Servis Faktörü	Tipi	Anma Akımı	Ağırlık	Ölçü Sayfası	Fiyat Kodu					
Power	Output Speeds	Output Torque	Output Power	Ratio	Per.O. Loads (Output)	Service Factors	Type	Rated Current	Weight	Dim. Page	Price Ref.					
Leistung P <sub>g</sub> [kW] P <sub>g</sub> [HP]	Abtriebswelle Drehzahlen n <sub>2</sub> [r.p.m]	Abtriebswelle Drehmomente M <sub>2</sub> [Nm]	Abtriebswelle Leistung P2 [kW]	Übersetzung i	Zul.Querkräfte (Abtrieb) F <sub>qam</sub> [N]	Betriebsfaktor f <sub>s</sub>	Typ	Nennstrom [A]	Gewicht ~ [kg]	Maße Seite	Preis No.					
<b>0,06</b> 0,08	18	15	0,02	<b>80</b>	1440	0,7	<b>EV030.00-56/4a</b>	0,25	3,9	68	E004					
	23	12	0,03	<b>60</b>	1310	0,8										
	28	11	0,03	<b>50</b>	1280	1,3										
	33	9	0,03	<b>42</b>	1210	1,7										
	41	8	0,03	<b>34</b>	1150	2,2										
	48	7	0,04	<b>29</b>	1290	2,3										
	56	7	0,04	<b>25</b>	1240	2,7										
	67	6	0,04	<b>21</b>	1180	2,8										
	82	5	0,04	<b>17</b>	1110	3,5										
	97	5	0,05	<b>14,5</b>	1060	4,0										
	133	3	0,05	<b>10,5</b>	960	4,8										
	193	3	0,05	<b>7,25</b>	980	6,7										
	267	2	0,05	<b>5,25</b>	1100	9,8										
<b>0,09</b> 0,12	1,1	179	0,02	<b>1218</b>	6200	0,8	<b>EV063-E030-56/4b</b>	0,63	10,4	102	E005					
	1,4	151	0,02	<b>986</b>	6200	0,8										
	1,7	139	0,02	<b>841</b>	6200	0,9										
	1,9	129	0,03	<b>725</b>	6200	1,0										
	2,3	101	0,02	<b>609</b>	6200	1,2										
	2,8	97	0,03	<b>493</b>	6200	1,3										
	3,3	85	0,03	<b>420,5</b>	6200	1,4										
	4,6	67	0,03	<b>304,5</b>	6200	1,8										
	6,7	59	0,04	<b>210,25</b>	6200	2,4										
	2,3	97	0,02	<b>609</b>	4800	0,8						<b>EV050-E030-56/4b</b>	0,63	8,1	101	E006
	2,8	106	0,03	<b>493</b>	4800	1,0										
	3,3	98	0,03	<b>421</b>	4800	1,0										
	3,9	89	0,04	<b>363</b>	4800	1,0										
4,6	71	0,03	<b>305</b>	4800	1,2											
5,7	68	0,04	<b>247</b>	4800	1,3											
6,7	61	0,04	<b>210</b>	4800	1,4											
8,0	53	0,05	<b>174</b>	4800	1,8											
10	47	0,05	<b>138</b>	4800	1,9											
4,2	74	0,03	<b>336</b>	3400	0,8	<b>EV040-E030-56/4b</b>	0,63	6,3	100	E007						
5,1	63	0,03	<b>272</b>	3400	1,0											
6,0	58	0,04	<b>232</b>	3400	1,1											
7,0	61	0,05	<b>200</b>	3400	1,2											
8,3	50	0,04	<b>168</b>	3400	1,4											
10	47	0,05	<b>136</b>	3400	1,3											
12	42	0,05	<b>116</b>	3400	1,6											
17	32	0,06	<b>84</b>	3400	1,9											
23	18	0,04	<b>60</b>	1320	0,6	<b>EV030-56/4b</b>	0,63	4	68	E008						
28	16	0,05	<b>50</b>	1280	0,9											
33	14	0,05	<b>42</b>	1220	1,1											
41	12	0,06	<b>34</b>	1150	1,4											
48	11	0,06	<b>29</b>	1290	1,6											
56	10	0,06	<b>25</b>	1240	1,8											
67	9	0,06	<b>21</b>	1180	1,9											
82	8	0,07	<b>17</b>	1110	2,3											
97	7	0,07	<b>14,5</b>	1060	2,7											
133	6	0,08	<b>10,5</b>	960	3,2											
193	4	0,08	<b>7,25</b>	980	4,4											
267	3	0,08	<b>5,25</b>	1100	6,6											



# E Serisi Motorlu Güç Devir Sayfaları

## E Series Geared Motors Performance Tables

### E Serien Getriebemotoren Leistung und Drehzahlübersicht

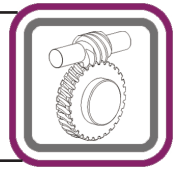

Güç	Çıkış Devri	Çıkış Momenti	Çıkış Gücü	Çevrim Oranı	Güv. Rad. Yük Çıkış	Servis Faktörü	Tipi	Anma Akımı	Ağırlık	Ölçü Sayfası	Fiyat Kodu					
Power	Output Speeds	Output Torque	Output Power	Ratio	Per.O. Loads (Output)	Service Factors	Type	Rated Current	Weight	Dim. Page	Price Ref.					
Leistung P <sub>g</sub> [kW] P <sub>g</sub> [HP]	Abtriebswelle Drehzahlen n <sub>2</sub> [r.p.m]	Abtriebswelle Drehmomente M <sub>2</sub> [Nm]	Abtriebswelle Leistung P2 [kW]	Übersetzung i	Zul.Querkräfte (Abtrieb) F <sub>qam</sub> [N]	Betriebsfaktor f <sub>s</sub>	Typ	Nennstrom [A]	Gewicht ~ [kg]	Maße Seite	Preis No.					
0,12 0,16	0,75	274	0,02	1860	7400	0,8	EV080-E040-63/4a	0,41	16,6	104	E009					
	0,93	307	0,03	1500	7400	0,9										
	1,1	289	0,03	1260	7400	1,0										
	1,5	213	0,03	930	7400	1,3										
	1,9	215	0,04	750	7400	1,7										
	2,2	196	0,05	630	7400	1,8										
	2,9	161	0,05	480	7400	2,2										
	3,7	138	0,05	375	7400	2,6										
	1,1	340	0,04	1260	7400	0,7						EV075-E040-63/4a	0,41	15	103	E010
	1,5	228	0,04	930	7400	1,1										
1,9	184	0,04	750	7400	1,3											
2,2	227	0,05	630	7400	1,3											
2,9	173	0,05	480	7400	1,7											
3,7	147	0,06	375	7400	1,9											
4,4	132	0,06	315	7400	2,1											
5,8	104	0,06	240	7400	2,5											
7,8	81	0,07	180	7400	3,2											
1,9	172	0,03	725	6200	0,8	EV063-E030-63/4a	0,41	10,8	102	E011						
2,3	135	0,03	609	6200	0,9											
2,8	129	0,04	493	6200	1,0											
3,3	114	0,04	420,5	6200	1,1											
4,6	90	0,04	304,5	6200	1,3											
6,7	79	0,06	210,25	6200	1,8											
3,8	120	0,05	366	6200	0,8	EV063-NR01-63/4a	0,41	15,6	108	E012						
4,6	128	0,06	306	6200	0,8											
6,0	100	0,06	234	6200	1,3											
8,0	75	0,06	174	6200	1,8											
9,2	83	0,08	153	6200	1,6											
12	66	0,08	117	6200	2,2											
2,8	141	0,04	493	6200	0,8	EV050-E030-63/4a	0,41	8,5	101	E013						
3,3	131	0,05	421	6200	0,8											
3,9	119	0,05	363	6200	0,8											
4,6	95	0,05	305	6200	0,9											
5,7	91	0,05	247	6200	1,0											
6,7	81	0,06	210	6200	1,1											
8,0	71	0,06	174	6200	1,3											
10	62	0,07	138	6200	1,4											
8,0	57	0,05	174	4800	1,0	EV050-NR01-63/4a	0,41	13,3	107	E014						
9,3	58	0,06	150	4800	1,0											
12	48	0,06	114	4800	1,0											
16	38	0,06	87	4800	1,0											
5,1	85	0,05	272	3400	0,8	EV040-E030-63/4a	0,41	6,7	100	E015						
6,0	78	0,05	232	3400	0,8											
7,0	82	0,06	200	3400	0,9											
8,3	66	0,06	168	3400	1,1											
10	62	0,07	136	3400	1,0											
12	56	0,07	116	3400	1,2											
17	43	0,07	84	3400	1,4											



# E Serisi Motorlu Güç Devir Sayfaları

## E Series Geared Motors Performance Tables

### E Serien Getriebemotoren Leistung und Drehzahlübersicht

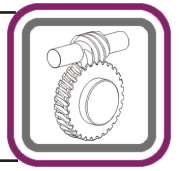

Güç	Çıkış Devri	Çıkış Momenti	Çıkış Gücü	Çevrim Oranı	Güv. Rad. Yük Çıkış	Servis Faktörü	Tipi	Anma Akımı	Ağırlık	Ölçü Sayfası	Fiyat Kodu					
Power	Output Speeds	Output Torque	Output Power	Ratio	Per.O. Loads (Output)	Service Factors	Type	Rated Current	Weight	Dim. Page	Price Ref.					
Leistung P <sub>g</sub> [kW] P <sub>g</sub> [HP]	Abtriebswelle Drehzahlen n <sub>2</sub> [r.p.m]	Abtriebswelle Drehmomente M <sub>2</sub> [Nm]	Abtriebswelle Leistung P2 [kW]	Übersetzung i	Zul.Querkräfte (Abtrieb) F <sub>qam</sub> [N]	Betriebsfaktor f <sub>s</sub>	Typ	Nennstrom [A]	Gewicht ~ [kg]	Maße Seite	Preis No.					
0,12 0,16	14	38	0,04	100	2440	0,8	EV040-63/4a	0,41	5,6	72	E016					
	18	32	0,06	80	2695	1,0										
	23	25	0,06	62	2960	1,3										
	28	23	0,07	50	2440	1,5										
	33	21	0,07	42	2370	1,8										
	44	17	0,08	32	2200	2,2										
	56	15	0,09	25	2100	2,5										
	67	13	0,09	21	2020	3,1										
	88	10	0,10	16	1870	3,9										
	117	8	0,10	12	1710	5,5										
	133	7	0,10	10,5	1640	5,6										
	175	6	0,11	8,0	1510	7,4										
	28	21	0,06	50	1090	0,7						EV030-63/4a	0,41	4,4	64	E017
	33	19	0,07	42	1040	0,8										
	41	16	0,07	34	1010	1,1										
	48	15	0,07	29	1150	1,2										
	56	13	0,08	25	1110	1,3										
67	12	0,08	21	1070	1,4											
82	10	0,04	17	1020	1,8											
97	8,9	0,05	14,5	980	2,0											
133	7,0	0,10	10,5	890	2,4											
193	5,1	0,10	7,25	920	3,3											
267	3,8	0,11	5,25	1040	4,9											
0,18 0,25	1,5	318	0,05	930	7400	0,9	EV080-E040-63/4b	0,6	17,1	104	E018					
	1,9	301	0,06	750	7400	1,1										
	2,2	303	0,07	630	7400	1,2										
	2,9	230	0,07	480	7400	1,4										
	3,7	206	0,08	375	7400	1,7										
	4,4	195	0,09	315	7400	1,9										
	5,8	148	0,09	240	7400	2,3										
	7,8	110	0,09	180	7400	2,8										
	1,5	228	0,05	930	7400	0,7						EV075-E040-63/4b	0,6	15	103	E019
	1,9	184	0,05	750	7400	0,8										
	2,2	227	0,08	630	7400	0,8										
	2,9	173	0,08	480	7400	1,1										
	3,7	147	0,09	375	7400	1,3										
	4,4	134	0,09	315	7400	1,4										
	5,8	106	0,10	240	7400	1,7										
	7,8	81	0,10	180	7400	2,2										
	3,8	152	0,09	373	7400	0,9										
4,7	131	0,10	298	7400	1,1											
6,3	106	0,10	224	7400	1,5											
7,5	99	0,12	186	7400	1,6											
9,4	84	0,12	149	7400	2,0											
13	66	0,13	112	7400	2,7											
4,6	124	0,06	304,5	6200	0,9	EV063-E030-63/4b	0,6	11,3	102	E021						
6,7	114	0,08	210,25	6200	1,2											
6,0	143	0,09	234	6200	0,8	EV063-NR01-63/4b	0,6	16,1	108	E022						



# E Serisi Motorlu Güç Devir Sayfaları

## E Series Geared Motors Performance Tables

### E Serien Getriebemotoren Leistung und Drehzahlübersicht

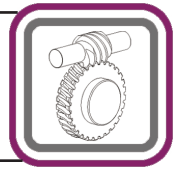

Güç	Çıkış Devri	Çıkış Momenti	Çıkış Gücü	Çevrim Oranı	Güv. Rad. Yük Çıkış	Servis Faktörü	Tipi	Anma Akımı	Ağırlık	Ölçü Sayfası	Fiyat Kodu
Power	Output Speeds	Output Torque	Output Power	Ratio	Per.O. Loads (Output)	Service Factors	Type	Rated Current	Weight	Dim. Page	Price Ref.
Leistung P <sub>g</sub> [kW] P <sub>g</sub> [HP]	Abtriebswelle Drehzahlen n <sub>2</sub> [r.p.m]	Abtriebswelle Drehmomente M <sub>2</sub> [Nm]	Abtriebswelle Leistung P2 [kW]	Übersetzung i	Zul.Querkräfte (Abtrieb) F <sub>qam</sub> [N]	Betriebsfaktor f <sub>s</sub>	Typ	Nennstrom [A]	Gewicht ~	Maße Seite	Preis No.
0,18 0,25	8,0	119	0,10	174	6200	1,2	EV063-NR01-63/4b	0,6	16,1	108	E022
	9,2	124	0,12	153	6200	1,1					
	12	95	0,12	117	6200	1,4					
9,0 11 15 18 23	84	0,08	100	6200	1,3	E063-71/6a	0,61	11,8	80	E023	
	78	0,09	82	6200	1,5						
	63	0,10	61	6200	1,9						
	58	0,11	51	6200	2,1						
	49	0,12	39	6200	2,8						
8,0 10	107	0,09	174	4800	0,9	EV050-E030-63/4b	0,6	10,7	101	E024	
	95	0,10	138	4800	0,9						
12 16	71	0,09	114	4800	0,8	EV050-NR01-63/4b	0,6	13,8	107	E025	
	59	0,10	87	4800	1,2						
11 15 18 24 31 36 47	78	0,09	83	4630	0,7	EV050-71/6a	0,8	9,5	76	E026	
	57	0,09	62	4300	1,0						
	53	0,10	50	4290	1,2						
	43	0,11	38	3860	1,7						
	36	0,12	29	3580	2,3						
	34	0,13	25	3490	2,3						
	28	0,14	19	3230	2,8						
14 17 23 28 37 48 56	61	0,08	100	2960	0,9	EV050-63/4b	0,6	7,8	76	E027	
	56	0,10	83	3430	0,9						
	41	0,10	62	3950	1,4						
	37	0,11	50	3770	1,6						
	30	0,12	38	3490	2,1						
	25	0,13	29	3540	2,9						
23	0,14	25	3430	3,0							
12 17	87	0,11	116	2400	0,8	EV040-E030-63/4b	0,6	7,2	100	E028	
	61	0,11	84	2700	0,9						
18 21 28 36 43 56 75 86	79	0,15	50	2410	0,8	EV040-71/6a	0,6	7,7	72	E029	
	63	0,14	42	2450	0,9						
	47	0,14	32	2310	1,1						
	34	0,13	25	2260	1,3						
	26	0,12	21	2300	1,6						
	18	0,11	16	2350	2,0						
	12	0,10	12	2360	2,9						
	9	0,09	10,5	2280	2,9						
18 23 28 33 44 56	48	0,06	80	1890	0,7	EV040-63/4b	0,6	6,5	72	E030	
	37	0,09	62	2550	0,8						
	34	0,10	50	2390	1,0						
	31	0,11	42	2360	1,2						
	26	0,12	32	2200	1,4						
	22	0,13	25	2120	1,7						



# E Serisi Motorlu Güç Devir Sayfaları

## E Series Geared Motors Performance Tables

### E Serien Getriebemotoren Leistung und Drehzahlübersicht

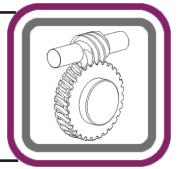

Güç	Çıkış Devri	Çıkış Momenti	Çıkış Gücü	Çevrim Oranı	Güv. Rad. Yük Çıkış	Servis Faktörü	Tipi	Anma Akımı	Ağırlık	Ölçü Sayfası	Fiyat Kodu
Power	Output Speeds	Output Torque	Output Power	Ratio	Per.O. Loads (Output)	Service Factors	Type	Rated Current	Weight	Dim. Page	Price Ref.
Leistung	Abtriebswelle Drehzahlen	Abtriebswelle Drehmomente	Abtriebswelle Leistung	Übersetzung	Zul.Querkräfte (Abtrieb)	Betriebsfaktor	Typ	Nennstrom	Gewicht	Maße Seite	Preis No.
$P_g$ [kW] $P_g$ [HP]	$n_2$ [r.p.m]	$M_2$ [Nm]	$P_2$ [kW]	$i$	$F_{qam}$ [N]	$f_s$		[A]	~ [kg]		
0,18 0,25	67	19	0,14	21	2110	2,1	EV040-63/4b	0,6	6,5	72	E030
	88	15	0,14	16	2140	2,6					
	117	12	0,15	12	2130	3,7					
	133	10	0,15	10,5	2050	3,7					
	175	8	0,16	8,0	2180	4,9					
	41	23	0,10	34	860	0,7	EV030-63/4b	0,6	4	64	E031
	48	21	0,11	29	1005	0,8					
	56	20	0,12	25	980	0,9					
	67	17	0,12	21	960	0,9					
	82	15	0,13	17	920	1,2					
	97	13	0,14	14,5	900	1,3					
	133	10	0,15	10,5	930	1,6					
	193	7	0,15	7,25	870	2,2					
	267	5	0,16	5,25	980	3,3					
0,25 0,34	0,85	783	0,07	1640	18000	1,0	EV125-E063-71/4a	0,81	73,5	106	E032
	1,2	710	0,09	1189	18000	1,7					
	1,6	558	0,09	884,5	18000	2,1					
	1,9	530	0,11	739,5	18000	2,2					
	2,5	415	0,11	565,5	18000	2,7					
	1,1	613	0,07	1240	8200	0,8	EV100-E050-71/4a	0,81	40,7	105	E033
	1,5	587	0,09	930	8200	1,1					
	1,9	499	0,10	750	8200	1,3					
	2,5	408	0,11	570	8200	1,6					
	3,2	334	0,11	435	8200	1,8					
	3,7	307	0,12	375	8200	2,0					
	4,9	228	0,12	285	8200	2,6					
	3,0	336	0,11	469,35	8200	0,9	EV100-NR11-71/4a	0,81	46,6	111	E034
	3,6	344	0,13	387,4	8200	1,2					
	4,7	274	0,14	298	8200	1,7					
	6,3	210	0,14	223,5	8200	2,4					
	7,2	225	0,17	193,7	8200	2,2					
	9,4	178	0,18	149	8200	3,1					
	1,9	448	0,09	750	7400	0,8	EV080-E040-71/4a	0,81	18,3	104	E035
	2,2	408	0,10	630	7400	0,9					
	2,9	336	0,10	480	7400	1,0					
	3,7	288	0,11	375	7400	1,2					
	4,4	263	0,12	315	7400	1,4					
	5,8	205	0,13	240	7400	1,6					
	7,8	160	0,13	180	7400	2,0					
	4,7	269	0,13	298	7400	1,0					
	6,3	206	0,14	223,5	7400	1,4					
	7,1	226	0,17	197,43	7400	1,2					
9,4	173	0,17	149	7400	1,8						
13	133	0,18	111,75	7400	2,6						



# E Serisi Motorlu Güç Devir Sayfaları

## E Series Geared Motors Performance Tables

### E Serien Getriebemotoren Leistung und Drehzahlübersicht

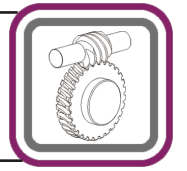

Güç	Çıkış Devri	Çıkış Momenti	Çıkış Gücü	Çevrim Oranı	Güv. Rad. Yük Çıkış	Servis Faktörü	Tipi	Anma Akımı	Ağırlık	Ölçü Sayfası	Fiyat Kodu
Power	Output Speeds	Output Torque	Output Power	Ratio	Per.O. Loads (Output)	Service Factors	Type	Rated Current	Weight	Dim. Page	Price Ref.
Leistung	Abtriebswelle Drehzahlen	Abtriebswelle Drehmomente	Abtriebswelle Leistung	Übersetzung	Zul.Querkräfte (Abtrieb)	Betriebsfaktor	Typ	Nennstrom	Gewicht	Maße Seite	Preis No.
P <sub>g</sub> [kW]	n <sub>2</sub> [r.p.m]	M <sub>2</sub> [Nm]	P2 [kW]	i	F <sub>qam</sub> [N]	f <sub>s</sub>		[A]	[kg]		
P <sub>g</sub> [HP]											
0,25 0,34	8,0	157	0,13	174	6200	0,9	EV063-NR01-71/4a	0,81	17,3	108	E037
	9,2	172	0,17	153	6200	0,8					
	12	138	0,17	117	6200	1,1					
2,9 3,7 4,4 5,8 7,8 8,9 12 18	360	0,11	480	7400	0,8	EV075-040-71/4a	0,81	18	103	E038	
	307	0,12	375	7400	0,9						
	279	0,13	315	7400	1,0						
	221	0,14	240	7400	1,2						
	169	0,14	180	7400	1,5						
	148	0,14	158	7400	1,7						
	133	0,16	120	7400	2,0						
	96	0,18	80	7400	2,8						
4,7 6,3 7,5 9,4 13	274	0,13	298	7400	0,8	EV075-NR11-71/4a	0,81	19	109	E039	
	220	0,14	224	7400	1,1						
	205	0,16	186	7400	1,2						
	174	0,17	149	7400	1,5						
	138	0,18	112	7400	1,9						
9,0 11 15 18 23 31 35	114	0,11	100	5540	0,9	EV063-71/6b	0,83	12,7	80	E040	
	107	0,12	82	6010	1,0						
	86	0,13	61	5580	1,4						
	83	0,15	51	5450	1,5						
	66	0,16	39	5060	2,1						
	52	0,17	29	5150	3,1						
	50	0,19	25,5	5020	2,6						
14 17 23 27 36	82	0,12	100	5110	1,2	EV063-71/4a	0,81	11,3	80	E041	
	77	0,14	82	5490	1,4						
	61	0,15	61	5060	2,0						
	57	0,17	51	4890	2,1						
	46	0,17	39	4520	3,0						
15 18 24 31 36 47 62	84	0,13	62	3880	0,7	EV050-71/6b	0,83	8	76	E042	
	76	0,14	50	3800	0,9						
	62	0,16	38	3580	1,2						
	50	0,16	29	3690	1,6						
	48	0,18	25	3640	1,7						
	38	0,19	19	3380	2,0						
	30	0,20	14,5	3700	2,8						
23 28 37 48 56 74	61	0,15	62	3680	1,0	EV050-71/4a	0,81	8	76	E043	
	53	0,16	50	3550	1,2						
	43	0,17	38	3310	1,5						
	35	0,18	29	3380	2,1						
	32	0,19	25	3300	2,2						
	26	0,20	19	3050	2,6						
21 28 36	62	0,14	42	2005	0,7	EV040-71/6b	0,83	8,7	72	E044	
	52	0,15	32	1930	0,8						
	45	0,17	25	1970	0,9						



## E Serisi Motorlu Güç Devir Sayfaları

### E Series Geared Motors Performance Tables

#### E Serien Getriebemotoren Leistung und Drehzahlübersicht

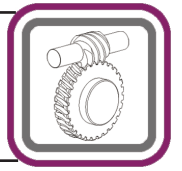

Güç	Çıkış Devri	Çıkış Momenti	Çıkış Gücü	Çevrim Oranı	Güv. Rad. Yük Çıkış	Servis Faktörü	Tipi	Anma Akımı	Ağırlık	Ölçü Sayfası	Fiyat Kodu
Power	Output Speeds	Output Torque	Output Power	Ratio	Per.O. Loads (Output)	Service Factors	Type	Rated Current	Weight	Dim. Page	Price Ref.
Leistung	Abtriebswelle Drehzahlen	Abtriebswelle Drehmomente	Abtriebswelle Leistung	Übersetzung	Zul.Querkräfte (Abtrieb)	Betriebsfaktor	Typ	Nennstrom	Gewicht	Maße Seite	Preis No.
$P_g$ [kW] $P_g$ [HP]	$n_2$ [r.p.m]	$M_2$ [Nm]	$P_2$ [kW]	$i$	$F_{qam}$ [N]	$f_s$		[A]	~ [kg]		
0,25 0,34	56	33	0,20	16	2170	1,5	EV040-71/6b	0,83	8,7	72	E044
	75	25	0,20	12	2190	2,1					
	86	23	0,21	10,5	2120	2,1					
	113	18	0,22	8,0	2270	2,8					
	23	58	0,13	62	2420	0,6	EV040-71/4a	0,81	7,3	72	E045
	28	47	0,14	50	2040	0,7					
	33	43	0,15	42	2080	0,8					
	44	35	0,16	32	1960	1,0					
	56	30	0,18	25	1940	1,2					
	67	28	0,19	21	1970	1,5					
	88	22	0,20	16	1920	1,9					
	117	17	0,21	12	2020	2,6					
	133	15	0,21	10,5	1950	2,7					
	175	12	0,22	8,0	2080	3,6					
0,37 0,50	1,2	1050	0,13	1189	8200	1,1	EV125-E063-71/4b	1,15	74,5	106	E046
	1,6	826	0,14	884,5	8200	1,4					
	1,9	784	0,16	739,5	8200	1,5					
	2,5	614	0,16	565,5	8200	1,8					
	3,3	478	0,17	420,5	8200	2,3					
	3,8	457	0,18	369,75	8200	2,5					
	5,0	371	0,19	282,75	8200	3,0					
	1,5	868	0,14	930	8200	0,8	EV100-E050-71/4b	1,15	41,7	105	E047
	1,9	738	0,14	750	8200	0,9					
	2,5	604	0,16	570	8200	1,1					
	3,2	494	0,17	435	8200	1,3					
	3,7	454	0,18	375	8200	1,4					
	4,9	338	0,17	285	8200	1,8					
	6,4	285	0,19	217,5	8200	2,1					
	7,8	268	0,22	180	8200	2,4					
	3,5	531	0,19	404,46	8200	0,8	EV100-NR11-71/4b	1,15	47,6	111	E048
	4,5	422	0,20	309,96	8200	1,1					
	5,9	331	0,20	238,14	8200	1,6					
	7,1	338	0,25	196,65	8200	1,5					
	9,3	267	0,26	151,2	8200	2,1					
	12	212	0,27	113,4	8200	3,1					
	8,4	223	0,20	107	8200	0,9	EV100-80/6a	1,1	39,8	92	E049
	11	187	0,21	82	8200	1,7					
	14	153	0,23	63	8200	3,3					
	3,7	426	0,17	375	7400	0,8	EV080-E040-71/4b	1,15	19,3	104	E050
	4,4	390	0,18	315	7400	0,9					
	5,8	303	0,19	240	7400	1,1					
	7,8	236	0,19	180	7400	1,4					
	6,3	305	0,20	223,5	7400	1,0	EV080-NR11-71/4b	1,15	26,9	110	E051
	7,1	334	0,25	197,43	7400	0,8					
9,4	256	0,25	149	7400	1,2						
13	197	0,26	111,75	7400	1,8						



# E Serisi Motorlu Güç Devir Sayfaları

## E Series Geared Motors Performance Tables

### E Serien Getriebemotoren Leistung und Drehzahlübersicht

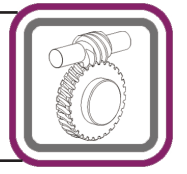

Güç	Çıkış Devri	Çıkış Momenti	Çıkış Gücü	Çevrim Oranı	Güv. Rad. Yük Çıkış	Servis Faktörü	Tipi	Anma Akımı	Ağırlık	Ölçü Sayfası	Fiyat Kodu
Power	Output Speeds	Output Torque	Output Power	Ratio	Per.O. Loads (Output)	Service Factors	Type	Rated Current	Weight	Dim. Page	Price Ref.
Leistung P <sub>g</sub> [kW] P <sub>g</sub> [HP]	Abtriebswelle Drehzahlen n <sub>2</sub> [r.p.m]	Abtriebswelle Drehmomente M <sub>2</sub> [Nm]	Abtriebswelle Leistung P2 [kW]	Übersetzung i	Zul.Querkräfte (Abtrieb) F <sub>qam</sub> [N]	Betriebsfaktor f <sub>s</sub>	Typ	Nennstrom [A]	Gewicht ~ [kg]	Maße Seite	Preis No.
0,37 0,50	11	174	0,20	82	6980	0,9	EV080-80/6a	1,1	26,9	88	E052
	15	139	0,21	62	7260	1,8					
	17	133	0,24	53	7120	1,9					
	23	105	0,25	40	7280	2,8					
4,4 5,8 7,8	413	0,19	315	7400	0,7	EV075-E040-71/4b	1,15	18	103	E053	
	327	0,20	240	7400	0,8						
	250	0,20	180	7400	1,0						
7,5 9,4 12,5	304	0,24	186,25	7400	0,8	EV075-NR11-71/4b	1,15	19	109	E054	
	258	0,25	149	7400	1,0						
	205	0,27	111,75	7400	1,3						
9,0 11 15 18 23 30 36	185	0,17	100	8000	0,9	EV075-80/6a	1,1	20	84	E134	
	166	0,20	80	7816	1,2						
	134	0,21	60	7378	1,6						
	122	0,23	50	7363	1,8						
	105	0,25	40	6896	2,2						
	84	0,26	30	7071	3,0						
	73	0,27	25	6969	3,2						
	11 15 18 23 31 35 46 62	158	0,18	82	5350						0,7
127		0,20	61	5050	0,9						
122		0,23	51	5040	1,0						
98		0,24	39	4720	1,4						
76		0,25	29	4840	2,1						
74		0,27	25,5	4770	1,8						
60		0,29	19,5	4430	2,3						
46		0,30	14,5	4470	3,2						
14 17 23 27 36 48 55 72	121	0,18	100	5700	0,8	EV063-71/4b	1,15	12,3	80	E056	
	114	0,20	82	5630	1,0						
	91	0,22	61	5240	1,3						
	85	0,24	51	5140	1,5						
	68	0,26	39	4780	2,0						
	53	0,27	29	4390	2,7						
	50	0,28	25,5	4290	2,3						
	40	0,30	19,5	3970	3,1						
24 31 36 47 62 75 95 124	91	0,23	38	3110	0,8	EV050-80/6a	1,1	12,2	76	E057	
	74	0,24	29	3250	1,1						
	71	0,27	25	3290	1,1						
	57	0,28	19	3080	1,4						
	44	0,29	14,5	3420	1,9						
	38	0,30	12	3260	2,2						
	32	0,31	9,5	3085	2,3						
	24	0,32	7,25	3530	3,2						
23 28 37 48	89	0,21	62	3050	0,7	EV050-71/4b	1,15	10	76	E058	
	78	0,23	50	3180	0,8						
	65	0,25	38	3000	1,0						
	53	0,26	29	3100	1,4						



# E Serisi Motorlu Güç Devir Sayfaları

## E Series Geared Motors Performance Tables

### E Serien Getriebemotoren Leistung und Drehzahlübersicht

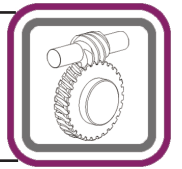

Güç	Çıkış Devri	Çıkış Momenti	Çıkış Gücü	Çevrim Oranı	Güv. Rad. Yük Çıkış	Servis Faktörü	Tipi	Anma Akımı	Ağırlık	Ölçü Sayfası	Fiyat Kodu	
Power	Output Speeds	Output Torque	Output Power	Ratio	Per.O. Loads (Output)	Service Factors	Type	Rated Current	Weight	Dim. Page	Price Ref.	
Leistung	Abtriebswelle Drehzahlen	Abtriebswelle Drehmomente	Abtriebswelle Leistung	Übersetzung	Zul.Querkräfte (Abtrieb)	Betriebsfaktor	Typ	Nennstrom	Gewicht	Maße Seite	Preis No.	
$P_g$ [kW] $P_g$ [HP]	$n_2$ [r.p.m]	$M_2$ [Nm]	$P2$ [kW]	$i$	$F_{qam}$ [N]	$f_s$		[A]	~ [kg]			
0,37 0,50	56	50	0,28	25	3080	1,5	EV050-71/4b	1,15	10	76	E058	
	74	38	0,29	19	2860	1,8						
	97	30	0,30	14,5	3140	2,4						
	117	25	0,31	12	2990	2,8						
	147	21	0,32	9,50	2800	3,0						
	193	16	0,33	7,25	3200	4,1						
	56	45	0,26	25	1610	0,8	EV040-71/4b	1,15	8,3	72	E059	
	67	41	0,28	21	1740	1,0						
	88	32	0,30	16	1810	1,3						
	117	25	0,30	12	1840	1,8						
	133	23	0,31	10,5	1780	1,8						
	175	18	0,33	8,0	1910	2,4						
	0,55 0,75	1,2	1561	0,19	1189	8200	0,8	EV125-E063-80/4a	1,6	75	106	E060
		1,6	1228	0,20	884,5	8200	1,0					
1,9		1165	0,23	739,5	8200	1,0						
2,5		912	0,24	565,5	8200	1,2						
3,3		710	0,25	420,5	8200	1,5						
3,8		680	0,27	369,75	8200	1,7						
5,0		552	0,29	282,75	8200	2,0						
6,7		473	0,33	210,25	8200	2,6						
7,6		430	0,34	184,88	8200	2,7						
4,7		562	0,28	299,46	8200	1,3	EV125-NR21-80/4a	1,6	87,8	112	E061	
5,6		575	0,34	251,16	8200	1,3						
7,2		449	0,34	193,2	8200	2,0						
10		336	0,35	140,07	8200	3,1						
11		349	0,41	125,58	8200	2,5						
3,2		734	0,25	435	8200	0,8	EV100-E050-80/4a	1,6	43,4	105	E062	
3,7		675	0,26	375	8200	0,9						
4,9		503	0,26	285	8200	1,2						
6,4		424	0,29	217,5	8200	1,4						
7,8		398	0,32	180	8200	1,6						
5,9		491	0,30	238,14	8200	0,9	EV100-NR11-80/4a	1,6	49,3	111	E063	
7,1		501	0,37	196,56	8200	1,0						
9,3		397	0,39	151,2	8200	1,4						
12		315	0,41	113,4	8200	2,0						
8,4		331	0,29	107	8199	0,7	EV100-80/6b	1,5	41,2	92	E064	
11		278	0,32	82	8200	1,2						
14		228	0,34	63	8200	2,2						
17		200	0,36	52	8200	2,3						
23		163	0,39	40	8200	3,2						
13		237	0,32	107	7050	0,9	EV100-80/4a	1,6	39,3	92	E065	
17		197	0,35	82	7630	1,6						
22		154	0,36	63	8090	2,9						
27		137	0,39	52	7700	3,0						



# E Serisi Motorlu Güç Devir Sayfaları

## E Series Geared Motors Performance Tables

### E Serien Getriebemotoren Leistung und Drehzahlübersicht

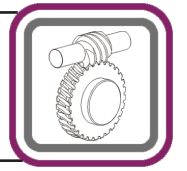

Güç	Çıkış Devri	Çıkış Momenti	Çıkış Gücü	Çevrim Oranı	Güv. Rad. Yük Çıkış	Servis Faktörü	Tipi	Anma Akımı	Ağırlık	Ölçü Sayfası	Fiyat Kodu
Power	Output Speeds	Output Torque	Output Power	Ratio	Per.O. Loads (Output)	Service Factors	Type	Rated Current	Weight	Dim. Page	Price Ref.
Leistung	Abtriebswelle Drehzahlen	Abtriebswelle Drehmomente	Abtriebswelle Leistung	Übersetzung	Zul.Querkräfte (Abtrieb)	Betriebsfaktor	Typ	Nennstrom	Gewicht	Maße Seite	Preis No.
P <sub>g</sub> [kW] P <sub>g</sub> [HP]	n <sub>2</sub> [r.p.m]	M <sub>2</sub> [Nm]	P2 [kW]	i	F <sub>gam</sub> [N]	f <sub>s</sub>		[A]	~ [kg]		
0,55 0,75	15	206	0,31	62	7400	1,2	EV080-80/6b	1,5	20,5	88	E066
	17	198	0,35	53	7400	1,3					
	23	156	0,37	40	6880	1,9					
	30	124	0,39	30	6360	2,6					
	34	116	0,41	26,5	6230	2,3					
	45	92	0,43	20	5740	3,3					
	17	182	0,32	82	5910	0,9	EV080-80/4a	1,6	18,6	88	E067
	23	147	0,35	62	6150	1,7					
	26	137	0,38	53	6060	1,7					
	35	108	0,40	40	6210	2,4					
	15	200	0,31	60	6752	1,0	EV075-80/6b	1,5	20	84	E068
	18	181	0,34	50	6552	1,1					
23	156	0,37	40	6219	1,4						
30	124	0,39	30	6458	1,8						
36	108	0,41	25	6195	2,0						
45	91	0,43	20	6422	2,4						
60	72	0,45	15	6468	3,1						
14	203	0,30	100	6941	0,9	EV075-80/4a	1,6	19	84	E069	
18	177	0,32	80	6663	1,0						
23	137	0,34	60	6268	1,4						
28	128	0,37	50	6006	1,6						
35	108	0,40	40	5682	2,0						
47	83	0,41	30	5850	2,6						
56	73	0,43	25	5582	2,8						
15	189	0,29	61	4240	0,7	EV063-80/6b	1,5	15,9	80	E070	
18	182	0,34	51	4420	0,7						
23	146	0,35	39	4210	1,0						
31	113	0,37	29	4370	1,3						
35	110	0,41	25,5	4380	1,2						
46	90	0,43	19,5	4110	1,5						
62	69	0,45	14,5	4180	2,4						
71	63	0,47	12,75	4050	2,0						
92	48	0,47	9,75	4120	2,7						
23	135	0,32	61	4200	0,9						EV063-80/4a
27	126	0,36	51	4230	1,0						
36	101	0,38	39	3980	1,4						
48	78	0,40	29	4100	1,8						
55	74	0,42	25,5	4040	1,6						
72	60	0,45	19,5	3760	2,1						
97	46	0,46	14,5	3800	3,0						
31	110	0,47	29	2600	0,7	EV050-80/6b	1,5	13,6	76	E072	
36	105	0,47	25	2760	0,8						
47	87	0,44	19	2640	0,9						
62	60	0,43	14,5	2980	1,3						
75	56	0,42	12	2880	1,5						
95	47	0,40	9,5	2770	1,6						
124	36	0,36	7,25	3200	2,2						



# E Serisi Motorlu Güç Devir Sayfaları

## E Series Geared Motors Performance Tables

### E Serien Getriebemotoren Leistung und Drehzahlübersicht

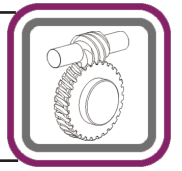

Güç	Çıkış Devri	Çıkış Momenti	Çıkış Gücü	Çevrim Oranı	Güv. Rad. Yük Çıkış	Servis Faktörü	Tipi	Anma Akımı	Ağırlık	Ölçü Sayfası	Fiyat Kodu
Power	Output Speeds	Output Torque	Output Power	Ratio	Per.O. Loads (Output)	Service Factors	Type	Rated Current	Weight	Dim. Page	Price Ref.
Leistung P <sub>g</sub> [kW] P <sub>g</sub> [HP]	Abtriebswelle Drehzahlen n <sub>2</sub> [r.p.m]	Abtriebswelle Drehmomente M <sub>2</sub> [Nm]	Abtriebswelle Leistung P <sub>2</sub> [kW]	Übersetzung i	Zul.Querkräfte (Abtrieb) F <sub>qam</sub> [N]	Betriebsfaktor f <sub>s</sub>	Typ	Nennstrom [A]	Gewicht ~ [kg]	Maße Seite	Preis No.
0,55 0,75	37	95	0,36	38	2550	0,7	EV050-80/4a	1,6	11,7	76	E073
	48	78	0,39	29	2680	1,0					
	56	71	0,42	25	2740	1,0					
	74	56	0,43	19	2580	1,2					
	97	44	0,45	14,5	2870	1,6					
	117	37	0,46	12	2740	1,9					
	147	31	0,48	9,50	2600	2,0					
	193	24	0,48	7,25	2990	2,8					
0,75 1,0	2,5	1244	0,32	565,5	8200	0,9	EV125-E063-80/4b	2,0	77,3	106	E074
	3,3	968	0,34	420,5	8200	1,1					
	3,8	927	0,37	369,75	8200	1,2					
	5,0	1018	0,39	282,75	8200	1,5					
	6,7	645	0,45	210,25	8200	1,9					
	7,6	586	0,47	184,88	8200	2,0					
	4,7	766	0,38	299,46	8200	1,0	EV125-NR21-80/4b	2,0	88,9	112	E075
	5,6	784	0,46	251,16	8200	1,0					
	7,2	603	0,46	193,2	8200	1,5					
	10	459	0,48	140,07	8200	2,2					
	11	475	0,56	125,58	8200	1,8					
	8,4	494	0,44	107	8200	0,9	EV125-90S/6	2,1	73,6	96	E076
	11	410	0,47	83	8200	1,6					
	15	321	0,49	62	8200	2,9					
	17	298	0,54	52	8200	2,8					
	4,9	685	0,35	285	8200	0,9	EV100-E050-80/4b	2,0	44,5	105	E077
	6,4	579	0,39	217,5	8200	1,0					
	7,8	543	0,44	180	8200	1,2					
	9,3	541	0,53	151,2	8200	1,0	EV100-NR11-80/4b	2,0	50,4	111	E078
	12	429	0,56	113,4	8200	1,5					
	11	378	0,44	82	7920	0,9	EV100-90S/6	2,1	43,1	92	E079
	14	311	0,47	63	8200	1,6					
	17	273	0,50	52	8200	1,7					
	23	223	0,53	40	8200	2,3					
	30	179	0,56	30	8200	3,3					
	17	268	0,48	82	7280	1,2					
	22	210	0,49	63	7750	2,1					
	27	186	0,53	52	7440	2,2					
	35	149	0,55	40	7780	3,0					
	47	117	0,57	30	7920	4,3					
	54	110	0,62	26	7660	3,7					



# E Serisi Motorlu Güç Devir Sayfaları

## E Series Geared Motors Performance Tables

### E Serien Getriebemotoren Leistung und Drehzahlübersicht

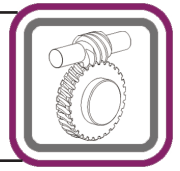

Güç	Çıkış Devri	Çıkış Momenti	Çıkış Gücü	Çevrim Oranı	Güv. Rad. Yük Çıkış	Servis Faktörü	Tipi	Anma Akımı	Ağırlık	Ölçü Sayfası	Fiyat Kodu
Power	Output Speeds	Output Torque	Output Power	Ratio	Per.O. Loads (Output)	Service Factors	Type	Rated Current	Weight	Dim. Page	Price Ref.
Leistung P <sub>g</sub> [kW] P <sub>g</sub> [HP]	Abtriebswelle Drehzahlen n <sub>2</sub> [r.p.m]	Abtriebswelle Drehmomente M <sub>2</sub> [Nm]	Abtriebswelle Leistung P2 [kW]	Übersetzung i	Zul.Querkräfte (Abtrieb) F <sub>qam</sub> [N]	Betriebsfaktor f <sub>s</sub>	Typ	Nennstrom [A]	Gewicht ~ [kg]	Maße Seite	Preis No.
<b>0,75</b> 1,0	15	281	0,43	<b>62</b>	6020	0,9	<b>EV080-90S/6</b>	2,1	22,4	88	E081
	17	270	0,48	<b>53</b>	6190	0,9					
	23	213	0,50	<b>40</b>	6420	1,4					
	30	170	0,53	<b>30</b>	6590	1,9					
	34	158	0,56	<b>26,5</b>	6510	1,7					
	45	126	0,59	<b>20</b>	6040	2,4					
	60	98	0,62	<b>15</b>	6080	3,4					
23	200	0,47	<b>62</b>	6370	1,2	<b>EV080-80/4b</b>	2,0	19,7	88	E082	
	26	187	0,52	<b>53</b>	6380						1,2
	35	147	0,54	<b>40</b>	5920						1,8
	47	115	0,56	<b>30</b>	5470						2,5
	53	106	0,59	<b>26,5</b>	5360						2,2
	70	83	0,61	<b>20</b>	4950						3,1
15	272	0,43	<b>60</b>	6024	0,7	<b>EV075-90S/6</b>	2,1	22	84	E083	
	18	247	0,47	<b>50</b>	5898						0,8
	23	213	0,50	<b>40</b>	5701						1,0
	30	170	0,53	<b>30</b>	6000						1,3
	36	147	0,56	<b>25</b>	5807						1,5
	45	124	0,59	<b>20</b>	6061						1,8
	60	98	0,62	<b>15</b>	6147						2,3
18	241	0,44	<b>80</b>	6062	0,8	<b>EV075-80/4b</b>	2,0	19	84	E084	
	23	187	0,46	<b>60</b>	5800						1,0
	28	174	0,51	<b>50</b>	5606						1,2
	35	147	0,54	<b>40</b>	5348						1,4
	47	114	0,56	<b>30</b>	5556						1,9
	56	100	0,59	<b>25</b>	5332						2,1
	70	83	0,61	<b>20</b>	5529						2,5
	93	64	0,63	<b>15</b>	5570						3,2
23	199	0,48	<b>39</b>	3650	0,7	<b>EV063-90S/6</b>	2,1	17,8	80	E085	
	31	155	0,50	<b>29</b>	3850						0,9
	35	150	0,56	<b>25,5</b>	3940						0,9
	46	123	0,59	<b>19,5</b>	3750						1,1
	62	93	0,61	<b>14,5</b>	3860						1,7
	71	86	0,64	<b>12,75</b>	3760						1,5
	92	66	0,64	<b>9,75</b>	3850						2,0
	124	51	0,66	<b>7,25</b>	4460						2,7
	36	138	0,52	<b>39</b>	3610						1,0
48		107	0,54	<b>29</b>	3750	1,3					
55		100	0,58	<b>25,5</b>	3760	1,1					
72		82	0,62	<b>19,5</b>	3530	1,5					
97		62	0,63	<b>14,5</b>	3590	2,2					
110		57	0,65	<b>12,75</b>	3490	1,9					
144		43	0,65	<b>9,75</b>	3540	2,8					
47	119	0,57	<b>19</b>	2150	0,7	<b>EV050-90S/6</b>	2,1	15,5	76	E087	
	62	88	0,59	<b>14,5</b>	2500						0,9
	75	76	0,60	<b>12</b>	2460						1,1
	95	64	0,64	<b>9,5</b>	2410						1,2
	124	50	0,65	<b>7,25</b>	2840						1,6



# E Serisi Motorlu Güç Devir Sayfaları

## E Series Geared Motors Performance Tables

### E Serien Getriebemotoren Leistung und Drehzahlübersicht

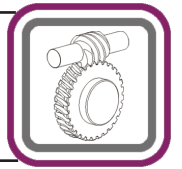

Güç	Çıkış Devri	Çıkış Momenti	Çıkış Gücü	Çevrim Oranı	Güv. Rad. Yük Çıkış	Servis Faktörü	Tipi	Anma Akımı	Ağırlık	Ölçü Sayfası	Fiyat Kodu
Power	Output Speeds	Output Torque	Output Power	Ratio	Per.O. Loads (Output)	Service Factors	Type	Rated Current	Weight	Dim. Page	Price Ref.
Leistung P <sub>g</sub> [kW] P <sub>g</sub> [HP]	Abtriebswelle Drehzahlen n <sub>2</sub> [r.p.m]	Abtriebswelle Drehmomente M <sub>2</sub> [Nm]	Abtriebswelle Leistung P2[kW]	Übersetzung i	Zul.Querkräfte (Abtrieb) F <sub>qam</sub> [N]	Betriebsfaktor f <sub>s</sub>	Typ	Nennstrom [A]	Gewicht ~ [kg]	Maße Seite	Preis No.
<b>0,75</b> 1,0	48	106	0,53	<b>29</b>	2220	0,7	<b>EV050-80/4b</b>	2,0	12,8	76	E088
	56	97	0,57	<b>25</b>	2360	0,7					
	74	76	0,59	<b>19</b>	2260	0,9					
	97	60	0,73	<b>14,5</b>	2560	1,2					
	117	51	0,73	<b>12</b>	2470	1,4					
	147	42	0,65	<b>9,5</b>	2370	1,5					
	193	33	0,66	<b>7,25</b>	2750	2,0					
<b>1,1</b> 1,5	3,3	1420	0,50	<b>420,5</b>	8200	0,8	<b>EV125-E063-90S/4</b>	2,6	73,7	106	E089
	3,8	1359	0,54	<b>369,75</b>	8200	0,8					
	5,0	1103	0,57	<b>282,75</b>	8200	1,0					
	6,7	947	0,66	<b>210,25</b>	8200	1,3					
	7,6	860	0,68	<b>184,88</b>	8200	1,4					
	7,2	884	0,67	<b>193,2</b>	8200	1,0	<b>EV125-NR21-90S/4</b>	2,6	91,7	112	E090
	10	673	0,70	<b>140,07</b>	8200	1,5					
	11	697	0,81	<b>125,58</b>	8200	1,2					
	8,4	764	0,64	<b>107</b>	8200	0,9	<b>EV125-90L/6</b>	3	75,9	96	E091
	11	601	0,68	<b>83</b>	8200	1,1					
	15	470	0,72	<b>62</b>	8200	2,0					
	17	437	0,79	<b>52</b>	8200	1,9					
	23	350	0,83	<b>40</b>	8200	2,8					
	6,4	849	0,57	<b>217,5</b>	4800	0,7	<b>EV100-E050-90S/4</b>	2,4	47,3	105	E092
	7,8	797	0,65	<b>180</b>	4800	0,8					
	14	456	0,68	<b>63</b>	7600	1,1	<b>EV100-90L/6</b>	3	45,4	92	E093
	17	401	0,73	<b>52</b>	7510	1,2					
	23	327	0,77	<b>40</b>	7990	1,6					
	30	263	0,83	<b>30</b>	8200	2,3					
	35	243	0,88	<b>26</b>	8100	2,0					
	45	194	0,91	<b>20</b>	7560	2,7					
	17	394	0,70	<b>82</b>	6670	0,8	<b>EV100-90S/4</b>	2,4	43,2	92	E094
	22	307	0,72	<b>63</b>	7180	1,4					
	27	273	0,77	<b>52</b>	6980	1,5					
	35	219	0,80	<b>40</b>	7350	2,1					
	47	171	0,84	<b>30</b>	7530	2,9					
	23	313	0,74	<b>40</b>	5630	0,9	<b>EV080-90L/6</b>	3	24,7	88	E095
	30	249	0,78	<b>30</b>	5870	1,3					
34	232	0,83	<b>26,5</b>	5910	1,1						
45	184	0,87	<b>20</b>	5540	1,7						
60	144	0,90	<b>15</b>	5470	2,3						
68	133	0,95	<b>13,25</b>	5520	1,9						
90	102	0,96	<b>10</b>	5550	2,8						



# E Serisi Motorlu Güç Devir Sayfaları

## E Series Geared Motors Performance Tables

### E Serien Getriebemotoren Leistung und Drehzahlübersicht

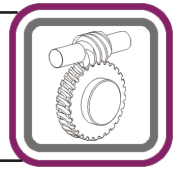

Güç	Çıkış Devri	Çıkış Momenti	Çıkış Gücü	Çevrim Oranı	Güv. Rad. Yük Çıkış	Servis Faktörü	Tipi	Anma Akımı	Ağırlık	Ölçü Sayfası	Fiyat Kodu
Power	Output Speeds	Output Torque	Output Power	Ratio	Per.O. Loads (Output)	Service Factors	Type	Rated Current	Weight	Dim. Page	Price Ref.
Leistung P <sub>g</sub> [kW] P <sub>g</sub> [HP]	Abtriebswelle Drehzahlen n <sub>2</sub> [r.p.m]	Abtriebswelle Drehmomente M <sub>2</sub> [Nm]	Abtriebswelle Leistung P2 [kW]	Übersetzung i	Zul.Querkräfte (Abtrieb) F <sub>qam</sub> [N]	Betriebsfaktor f <sub>s</sub>	Typ	Nennstrom [A]	Gewicht ~ [kg]	Maße Seite	Preis No.
1,1 1,5	23	293	0,69	62	5000	0,8	EV080-90S/4	2,6	22,5	88	E096
	26	274	0,76	53	5190	0,8					
	35	216	0,79	40	5410	1,2					
	47	169	0,83	30	5560	1,7					
	53	155	0,86	26,5	5520	1,5					
	70	122	0,89	20	5130	2,1					
	93	95	0,92	15	5180	2,9					
23	313	0,74	40	5325	0,7	EV075-90L/6	3	23	84	E097	
	30	249	0,78	30	5198						0,9
	36	216	0,81	25	5127						1,0
	45	182	0,86	20	4935						1,2
	60	144	0,90	15	4635						1,6
	90	102	0,96	10	4228						2,1
	120	77	0,97	8	3911						2,6
	23	275	0,67	60	5535						0,7
28		255	0,75	50	5449	0,8					
35		216	0,79	40	5295	1,0					
47		167	0,81	30	5041	1,3					
56		146	0,86	25	4895	1,4					
70		122	0,89	20	4657	1,7					
93		95	0,92	15	4341	2,2					
140		66	0,97	10	3896	3,0					
46	180	0,87	19,5	3130	0,8	EV063-90L/6	3	20,1	80	E099	
	62	137	0,89	14,5	3290						1,2
	71	126	0,94	12,75	3250						1,0
	92	97	0,94	9,75	3390						1,3
	124	74	0,97	7,25	3990						2,0
48	157	0,79	29	3160	0,9	EV063-90S/4	2,6	17,9	80	E100	
	55	147	0,85	25,5	3280						0,8
	72	120	0,90	19,5	3130						1,0
	97	91	0,92	14,5	3230						1,5
	110	83	0,96	12,75	3160						1,3
	144	64	0,96	9,75	3250						1,9
	193	49	0,99	7,25	3770						2,6
75	112	0,88	12	1730	0,7	EV050-90L/6	3	17,8	76	E101	
	95	94	0,94	9,5	1790						0,8
	124	73	0,95	7,25	2200						1,1
97	89	0,90	14,5	2010	0,8	EV050-90S/4	2,6	15,6	76	E102	
	117	75	0,91	12	2000						0,9
	147	62	0,96	9,5	1980						1,0
	193	48	0,97	7,25	2340						1,4
	1,5 2,0	6,7	1291	0,90	210,25						8200
7,6		1173	0,93	184,86	8200	1,0					
10	917	0,96	140,07	8200	1,1	EV125-NR21-90L/4	3,5	93,8	112	E104	
	11	951	1,11	125,58	8200						0,9



# E Serisi Motorlu Güç Devir Sayfaları

## E Series Geared Motors Performance Tables

### E Serien Getriebemotoren Leistung und Drehzahlübersicht

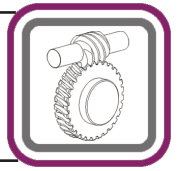

Güç	Çıkış Devri	Çıkış Momenti	Çıkış Gücü	Çevrim Oranı	Güv. Rad. Yük Çıkış	Servis Faktörü	Tipi	Anma Akımı	Ağırlık	Ölçü Sayfası	Fiyat Kodu
Power	Output Speeds	Output Torque	Output Power	Ratio	Per.O. Loads (Output)	Service Factors	Type	Rated Current	Weight	Dim. Page	Price Ref.
Leistung P <sub>g</sub> [kW] P <sub>g</sub> [HP]	Abtriebswelle Drehzahlen n <sub>2</sub> [r.p.m]	Abtriebswelle Drehmomente M <sub>2</sub> [Nm]	Abtriebswelle Leistung P2 [kW]	Übersetzung i	Zul.Querkräfte (Abtrieb) F <sub>qam</sub> [N]	Betriebsfaktor f <sub>s</sub>	Typ	Nennstrom [A]	Gewicht ~ [kg]	Maße Seite	Preis No.
1,5 2,0	11	819	0,93	83	8200	0,8	EV125-100L/6	3,5	81,6	96	E105
	15	641	0,98	62	8200	1,5					
	17	596	1,08	52	8200	1,4					
	23	478	1,13	40	8200	2,0					
	31	351	1,14	29	8200	3,1					
	35	343	1,25	26	8200	2,5					
	45	271	1,28	20	8200	3,6					
	14	622	0,93	63	6570	0,8	EV100-100L/6	3,5	51,1	92	E106
	17	546	0,99	52	6680	0,8					
	23	446	1,05	40	7230	1,2					
	30	358	1,13	30	7530	1,7					
	35	331	1,20	26	7500	1,4					
	45	264	1,25	20	7080	2,0					
	60	203	1,28	15	8200	2,9					
	69	178	1,29	13	8200	2,5					
	90	140	1,32	10	8200	3,4					
	22	419	0,98	63	6520	1,1	EV100-90L/4	3,5	45,3	92	E107
	27	372	1,05	52	6450	1,1					
	35	299	1,10	40	6870	1,5					
	47	233	1,14	30	7080	2,1					
	54	221	1,25	26	6960	1,9					
	70	174	1,28	20	6510	2,5					
	23	427	1,01	40	4730	0,7	EV080-100L/6	3,5	30,4	92	E108
	30	339	1,07	30	5060	1,0					
	34	316	1,13	26,5	5230	0,8					
	45	251	1,19	20	4990	1,2					
	60	196	1,23	15	5140	1,7					
68	181	1,29	13,25	5012	1,4						
90	138	1,31	10	5120	2,0						
120	105	1,32	7,50	6250	2,6						
35	295	1,08	40	4830	0,9	EV080-90L/4	3,5	24,6	88	E109	
47	230	1,13	30	4580	1,3						
53	211	1,17	26,5	4620	1,1						
70	166	1,22	20	4330	1,6						
93	129	1,26	15	4040	2,1						
106	118	1,31	13,25	3920	1,8						
140	91	1,34	10	3660	2,6						
187	68	1,34	7,5	3390	3,7						
30	339	1,07	30,00	5412	0,7	EV075-100L/6	3,5	30	84	E110	
36	294	1,11	25,00	5156	0,7						
45	248	1,17	20,00	5035	0,9						
60	196	1,23	15,00	4613	1,1						
90	138	1,31	10,00	3880	1,5						
120	105	1,32	7,50	3752	1,9						
35	295	1,08	40,00	4807	0,7	EV075-90L/4	3,5	21	84	E111	
47	227	1,11	30,00	4526	1,0						
56	200	1,17	25,00	4326	1,0						
70	166	1,22	20,00	4214	1,3						



# E Serisi Motorlu Güç Devir Sayfaları

## E Series Geared Motors Performance Tables

### E Serien Getriebemotoren Leistung und Drehzahlübersicht

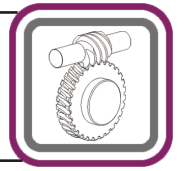

Güç	Çıkış Devri	Çıkış Momenti	Çıkış Gücü	Çevrim Oranı	Güv. Rad. Yük Çıkış	Servis Faktörü	Tipi	Anma Akımı	Ağırlık	Ölçü Sayfası	Fiyat Kodu	
Power	Output Speeds	Output Torque	Output Power	Ratio	Per.O. Loads (Output)	Service Factors	Type	Rated Current	Weight	Dim. Page	Price Ref.	
Leistung P <sub>g</sub> [kW] P <sub>g</sub> [HP]	Abtriebswelle Drehzahlen n <sub>2</sub> [r.p.m]	Abtriebswelle Drehmomente M <sub>2</sub> [Nm]	Abtriebswelle Leistung P2 [kW]	Übersetzung i	Zul.Querkräfte (Abtrieb) F <sub>qam</sub> [N]	Betriebsfaktor f <sub>s</sub>	Typ	Nennstrom [A]	Gewicht ~ [kg]	Maße Seite	Preis No.	
1,5 2,0	93	129	1,26	15,00	3847	1,6	EV075-90L/4	3,5	21	84	E111	
	140	90	1,32	10,00	3210	2,2						
	187	68	1,34	7,50	3405	2,7						
	72	164	1,23	19,5	2670	0,8	EV063-90L/4	3,5	20	80	E112	
	97	125	1,26	14,5	2810	1,1						
	110	114	1,31	12,75	2780	0,9						
	144	87	1,31	9,75	2910	1,2						
	193	67	1,35	7,25	3420	1,9						
	147	85	1,31	9,5	1520	0,7	EV050-90L/4	3,5	17,7	76	E113	
	193	65	1,32	7,25	1870	1,0						
	2,2 3,0	15	941	1,43	62	8200	1,0	EV125-112M/6	5,1	91,2	96	E114
		17	874	1,58	52	8200	1,0					
		23	700	1,65	40	8200	1,4					
		31	515	1,67	29	8200	2,1					
		35	504	1,83	26	8200	1,7					
45		397	1,87	20	8200	2,4						
62		291	1,89	14,5	8200	3,7						
17		810	1,43	83	8200	0,8	EV125-100L/4a	5,1	79,5	96	E115	
23		605	1,43	62	8200	1,3						
27		593	1,67	52	8200	1,2						
35		456	1,67	40	8200	1,8						
48		331	1,67	29	8200	2,7						
54		328	1,85	26	8200	2,2						
70		258	1,89	20	8200	3,1						
23		626	1,47	40	5910	0,8	EV100-112M/6	5,1	60,7	92	E116	
30		497	1,56	30	6300	1,1						
35		455	1,65	26	6490	1,0						
45		369	1,74	20	6250	1,4						
60		287	1,80	15	8230	2,0						
69		261	1,89	13	7980	1,7						
90		203	1,91	10	7570	2,4						
120		154	1,94	7,5	7060	3,4						
27		546	1,54	52	5530	0,8	EV100-100L/4a	5,1	49	92	E117	
35		438	1,61	40	6020	1,0						
47		342	1,67	30	6290	1,5						
54		324	1,83	26	6310	1,3						
70		255	1,87	20	5970	1,7						
93		194	1,89	15	7780	2,5						
108		172	1,94	13	7500	2,2						
140		134	1,96	10	7040	3,0						
187	101	1,98	7,5	6510	4,3							
45	369	1,74	20	4000	0,8	EV080-112M/6	5,1	40	88	E118		
60	287	1,80	15	4260	1,1							
68	266	1,89	13,25	4200	1,0							
90	203	1,91	10	4400	1,4							
120	154	1,94	7,5	5480	2,0							



# E Serisi Motorlu Güç Devir Sayfaları

## E Series Geared Motors Performance Tables

### E Serien Getriebemotoren Leistung und Drehzahlübersicht

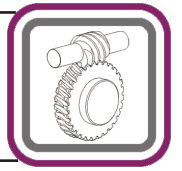

Güç	Çıkış Devri	Çıkış Momenti	Çıkış Gücü	Çevrim Oranı	Güv. Rad. Yük Çıkış	Servis Faktörü	Tipi	Anma Akımı	Ağırlık	Ölçü Sayfası	Fiyat Kodu					
Power	Output Speeds	Output Torque	Output Power	Ratio	Per.O. Loads (Output)	Service Factors	Type	Rated Current	Weight	Dim. Page	Price Ref.					
Leistung P <sub>g</sub> [kW] P <sub>g</sub> [HP]	Abtriebswelle Drehzahlen n <sub>2</sub> [r.p.m]	Abtriebswelle Drehmomente M <sub>2</sub> [Nm]	Abtriebswelle Leistung P2 [kW]	Übersetzung i	Zul.Querkräfte (Abtrieb) F <sub>qam</sub> [N]	Betriebsfaktor f <sub>s</sub>	Typ	Nennstrom [A]	Gewicht ~ [kg]	Maße Seite	Preis No.					
2,2 3,0	47	338	1,65	30	4120	0,9	EV080-100L/4a	5,1	28,3	88	E119					
	53	310	1,72	26,5	4310	0,7										
	70	243	1,78	20	4130	1,1										
	93	189	1,85	15	4290	1,5										
	106	173	1,91	13,25	4190	1,2										
	140	134	1,96	10	4290	1,8										
	187	100	1,96	7,5	5260	2,5										
	45	364	1,72	20,0	5035	0,6						EV075-112M/6	5,1	36	84	E120
	60	287	1,80	15,0	4613	0,8										
	90	203	1,91	10,0	3880	1,1										
	120	154	1,94	7,5	3752	1,3										
	47	333	1,63	30,0	4526	0,7	EV075-100L/4a	5,1	27	84	E121					
	56	293	1,72	25,0	4326	0,7										
	70	243	1,78	20,0	4214	0,9										
	93	189	1,85	15,0	3847	1,1										
	140	132	1,94	10,0	3210	1,5										
	187	100	1,96	7,5	3405	1,9										
	3,0 4,0	23	955	2,25	40	8200	1,0	EV125-132S/6	6,9	100,2	96	E122				
31		702	2,28	29	8200	1,5										
35		687	2,49	26	8200	1,3										
45		541	2,55	20	8200	1,8										
62		397	2,58	14,5	7570	2,7										
69		364	2,64	13	7430	2,2										
90		287	2,70	10	7000	3,1										
23		825	1,95	62	8130	1,0	EV125-100L/4b						6,45	82,9	96	E123
27		809	2,28	52	8200	0,9										
35		622	2,28	40	8200	1,3										
48		451	2,28	29	8200	2,0										
54		447	2,52	26	8200	1,6										
70		352	2,58	20	8200	2,3										
97		255	2,58	14,5	8200	3,4										
108		237	2,67	13	8200	2,8										
140		184	2,70	10	8200	3,9										
35		598	2,19	40	5050	0,8	EV100-100L/4b	6,45	52,4	92	E124					
47		467	2,28	30	5390	1,1										
54		442	2,49	26	5560	0,9										
70		348	2,55	20	5360	1,3										
93		264	2,58	15	7060	1,8										
108		237	2,67	13	6850	1,6										
140		182	2,67	10	6500	2,2										
187		138	2,70	7,5	6070	3,2										
70		332	2,43	20	3410	0,8	EV080-100L/4b	6,45	31,7	88	E125					
93		258	2,52	15	3640	1,1										
106		236	2,61	13,25	3600	0,9										
140	182	2,67	10	3770	1,3											
187	137	2,67	7,5	3700	1,8											



# E Serisi Motorlu Güç Devir Sayfaları

## E Series Geared Motors Performance Tables

### E Serien Getriebemotoren Leistung und Drehzahlübersicht

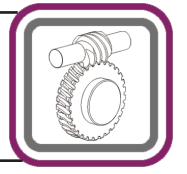

Güç	Çıkış Devri	Çıkış Momenti	Çıkış Gücü	Çevrim Oranı	Güv. Rad. Yük Çıkış	Servis Faktörü	Tipi	Anma Akımı	Ağırlık	Ölçü Sayfası	Fiyat Kodu
Power	Output Speeds	Output Torque	Output Power	Ratio	Per.O. Loads (Output)	Service Factors	Type	Rated Current	Weight	Dim. Page	Price Ref.
Leistung P <sub>g</sub> [kW] P <sub>g</sub> [HP]	Abtriebswelle Drehzahlen n <sub>2</sub> [r.p.m]	Abtriebswelle Drehmomente M <sub>2</sub> [Nm]	Abtriebswelle Leistung P <sub>2</sub> [kW]	Übersetzung i	Zul.Querkräfte (Abtrieb) F <sub>qam</sub> [N]	Betriebsfaktor f <sub>s</sub>	Typ	Nennstrom [A]	Gewicht ~ [kg]	Maße Seite	Preis No.
3,0 4,0	93 140 187	258 180 137	2,52 2,64 2,67	15,0 10,0 7,5	3847 3210 3405	0,8 1,1 1,4	EV075-100L/4b	6,45	30,5	84	E126
4,0 5,5	23 31 35 45 62 69 90 124	1273 935 916 722 529 486 382 280	3,00 3,04 3,32 3,40 3,44 3,52 3,60 3,64	40 29 26 20 14,5 13 10 7,25	7260 8200 8200 8200 8200 8200 8200 8200	0,8 1,2 0,9 1,3 2,0 1,6 2,3 3,4	EV125-132M/6a	9	107,6	96	E127
	27 35 48 54 70 97 108 140 193	1078 829 601 596 469 340 316 246 180	3,04 3,04 3,04 3,36 3,44 3,44 3,56 3,60 3,64	52 40 29 26 20 14,5 13 10 7,25	7173 7730 8200 8200 8200 8200 8200 8200 8200	0,7 1,0 1,5 1,2 1,7 2,6 2,1 3,0 4,3	EV125-112M/4	8,2	87	96	E128
	47 54 70 93 108 140 187	622 589 464 352 312 243 184	3,04 3,32 3,40 3,44 3,52 3,56 3,60	30 26 20 15 13 10 7,5	4260 4620 4590 6170 6030 5830 5520	0,8 0,7 1,0 1,4 1,2 1,7 2,4	EV100-112M/4	8,2	61,2	92	E129
	93 106 140 187	344 315 243 182	3,36 3,48 3,56 3,56	15 13,25 10 7,5	2840 2850 3110 3990	0,8 0,7 1,0 1,4	EV080-112M/4	8,2	40,5	88	E130
	93 140 187	344 240 182	3,36 3,52 3,56	15,0 10,0 7,5	3847 3210 3405	0,6 0,8 1,0	EV075-112M/4	8,2	39	84	E131
5,5 7,5	35 48 54 70 97 108 140 193	1141 827 819 645 468 434 338 248	4,18 4,18 4,62 4,73 4,73 4,90 4,95 5,01	40 29 26 20 14,5 13 10 7,25	6120 7040 7650 7430 8200 8200 8200 8200	0,7 0,9 0,9 1,2 1,9 1,5 2,1 3,2	EV125-132S/4	11,4	101,2	96	E132
7,5 10	70 97 108 140 193	880 638 592 460 338	6,45 6,45 6,68 6,75 6,83	20 14,5 13 10 7,25	4970 4780 4820 4730 4460	0,9 1,4 1,1 1,6 2,3	EV125-132M/4	15,3	109,2	96	E133

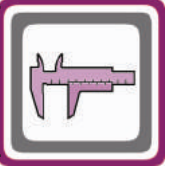
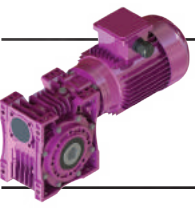

# Ölçü Sayfaları

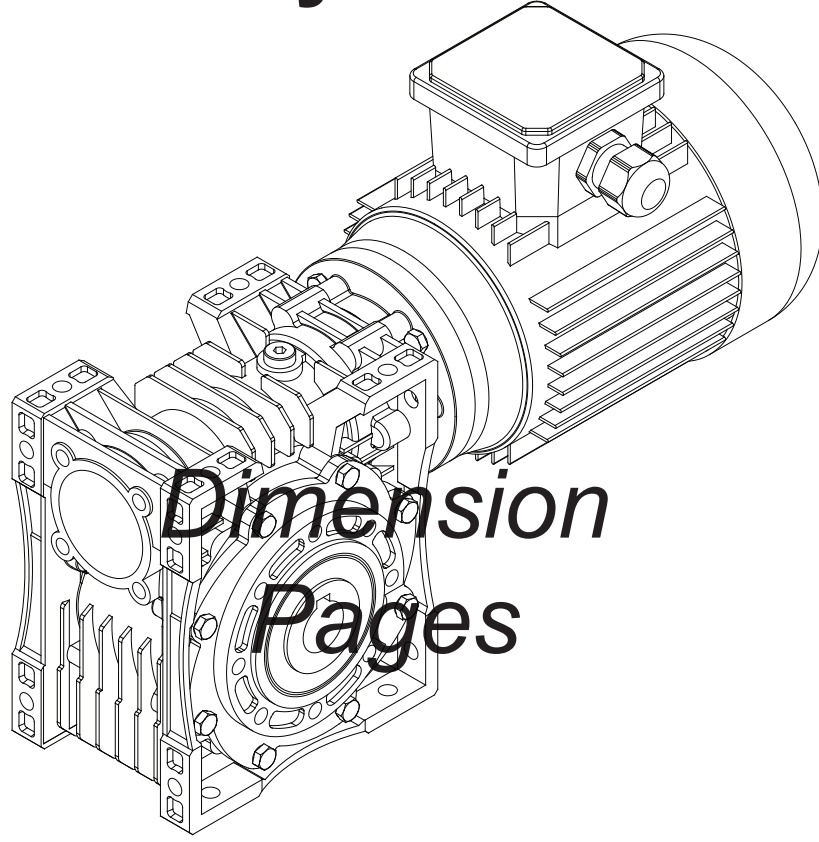

## Abmessungenseiten









# Ölçü Sayfaları

## Dimension Pages

### Abmessungsseiten

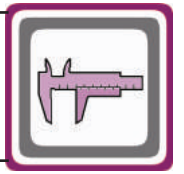

-Mil ucu çekirme deliği DIN 332 sayfa 2 / Tapped center hole to DIN 332, sheet 2 / Zentrierung mit Gewinde DIN 332, Blatt 2

EV030.08

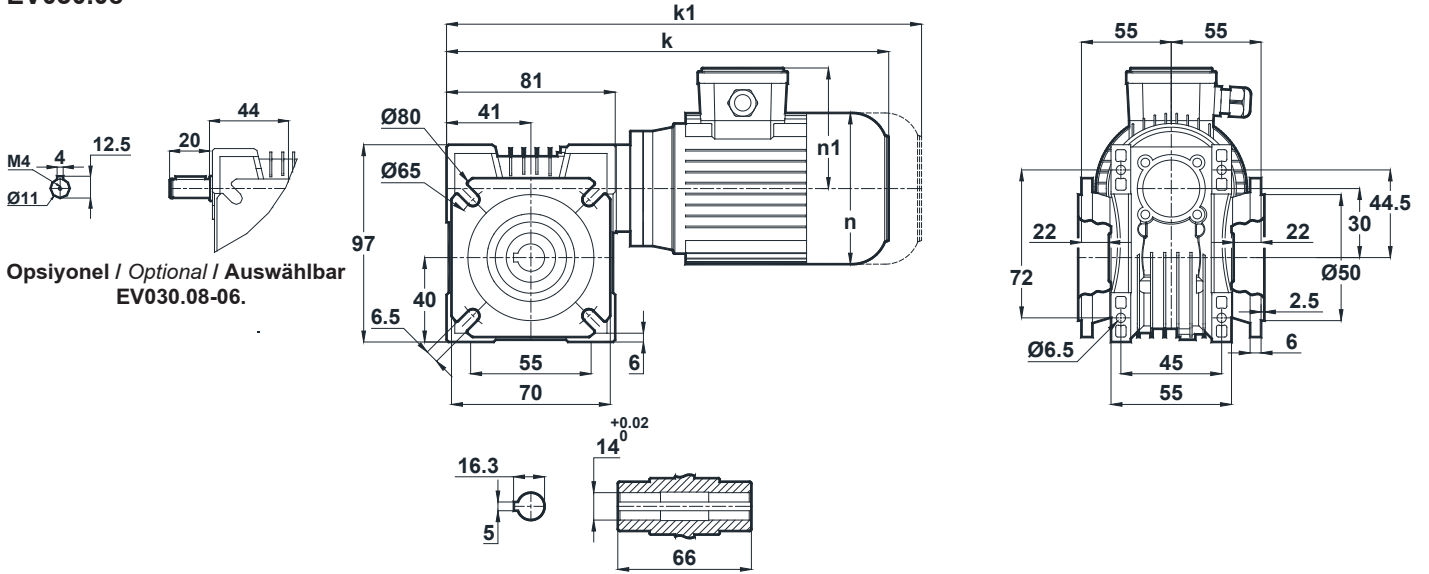

IEC B14	56	63
k	235,5	287,5
k1	-	340,5
n	105	121
n1	96	97

Klemens Pozisyonları / Terminal Box Positions / Klemmenkasten

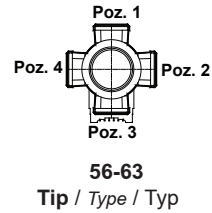

Motorlar B14 flanş ile bağlanmıştır. / Motor connections are with IEC B14 Flange / Motor Befestigung mit IEC B14 Flansch.

"k1" Ölçüsü frenli redüktörlere aittir. 56,63,71 tip elektrik motorlu redüktörler soğutmasız, diğerleri soğutmalıdır.

Dimensions "k1" is for motors with brake. Gearboxes with 56,63,71 type electrical motors are not fan cooled, other types are fan cooled.

Maße "k1" sind für Bremsmotoren. Getrieben mit 56,63,71 Motortypen sind ohne Kühlung, andere Typen sind mit Ventilator gekühlt.



# Ölçü Sayfaları Dimension Pages Abmessungsseiten

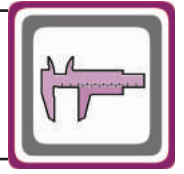

-Mil ucu çekirme deliği DIN 332 sayfa 2 / Tapped center hole to DIN 332, sheet 2 / Zentrierung mit Gewinde DIN 332, Blatt 2

## EV040.00

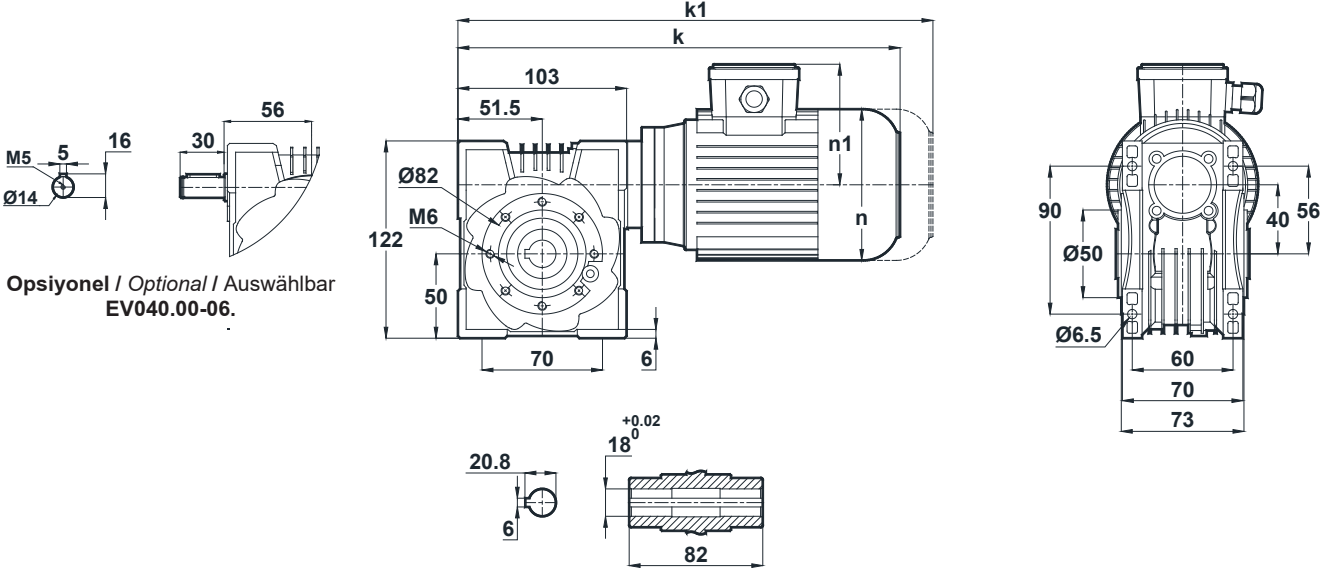

## EV040.01

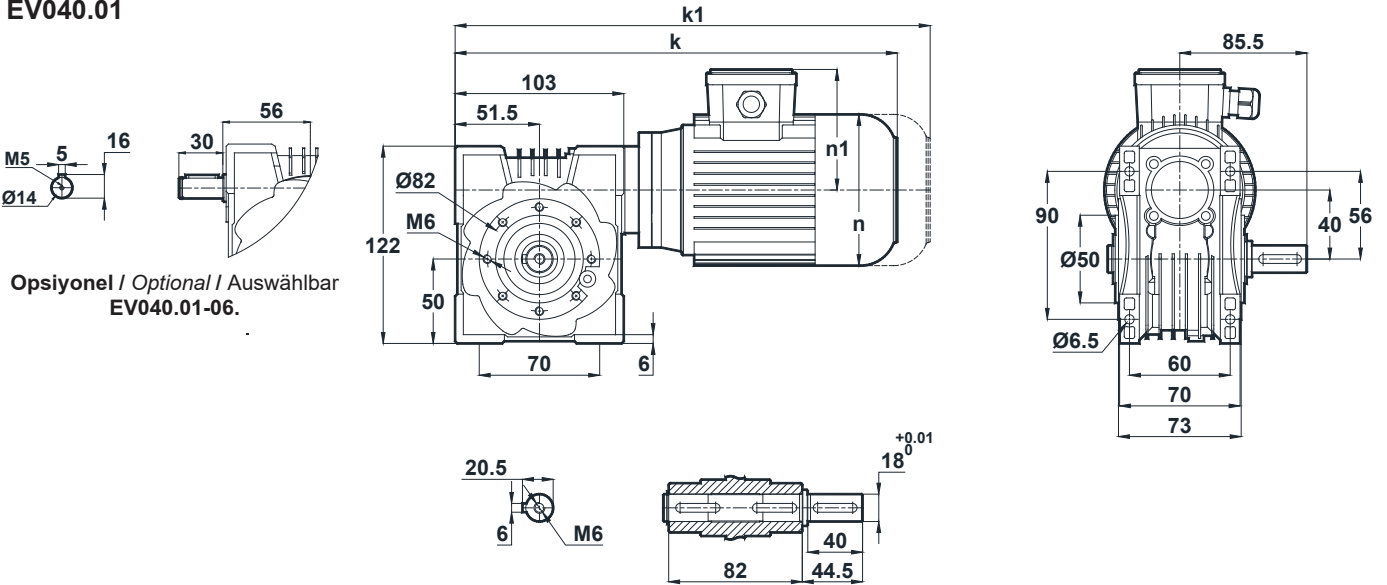

IEC B14	63	71
k	321	347
k1	374	467
n	121	138
n1	97	110

Klemens Pozisyonları / Terminal Box Positions / Klemmenkasten

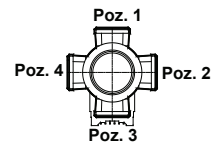

63-71  
Tip / Type / Typ

Motorlar B14 flanş ile bağlanmıştır. / Motor connections are with IEC B14 Flange / Motor Befestigung mit IEC B14 Flansch.  
"k1" Ölçüsü frenli redüktörlere aittir. 56,63,71 tip elektrik motorlu redüktörler soğutmasız, diğerleri soğutmalıdır.  
Dimensions "k1" is for motors with brake. Gearboxes with 56,63,71 type electrical motors are not fan cooled, other types are fan cooled.  
Maße "k1" ist für Bremsenmotoren. Getrieben mit 56,63,71 typ Motoren sind ohne Kühlung, andere Typen zind mit Ventilator gekühlt.



# Ölçü Sayfaları Dimension Pages Abmessungenseiten

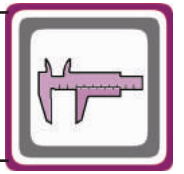

-Mil ucu çekirme deliği DIN 332 sayfa 2 / Tapped center hole to DIN 332, sheet 2 / Zentrierung mit Gewinde DIN 332, Blatt 2

## EV040.02

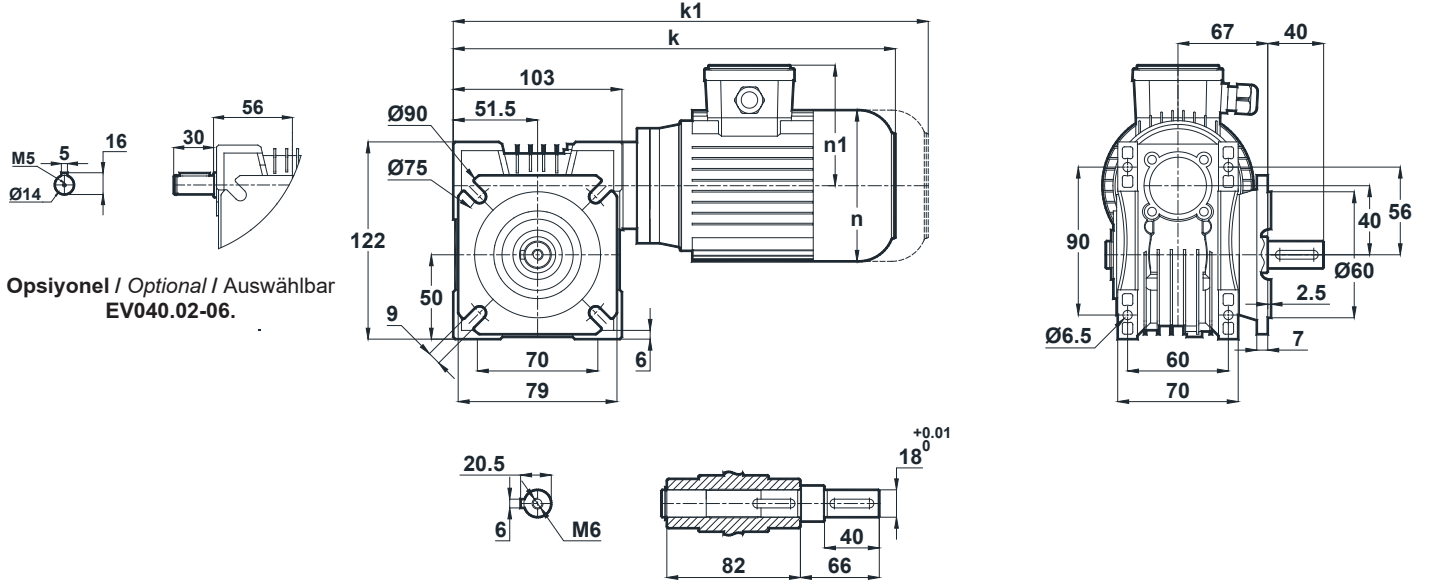

## EV040.03

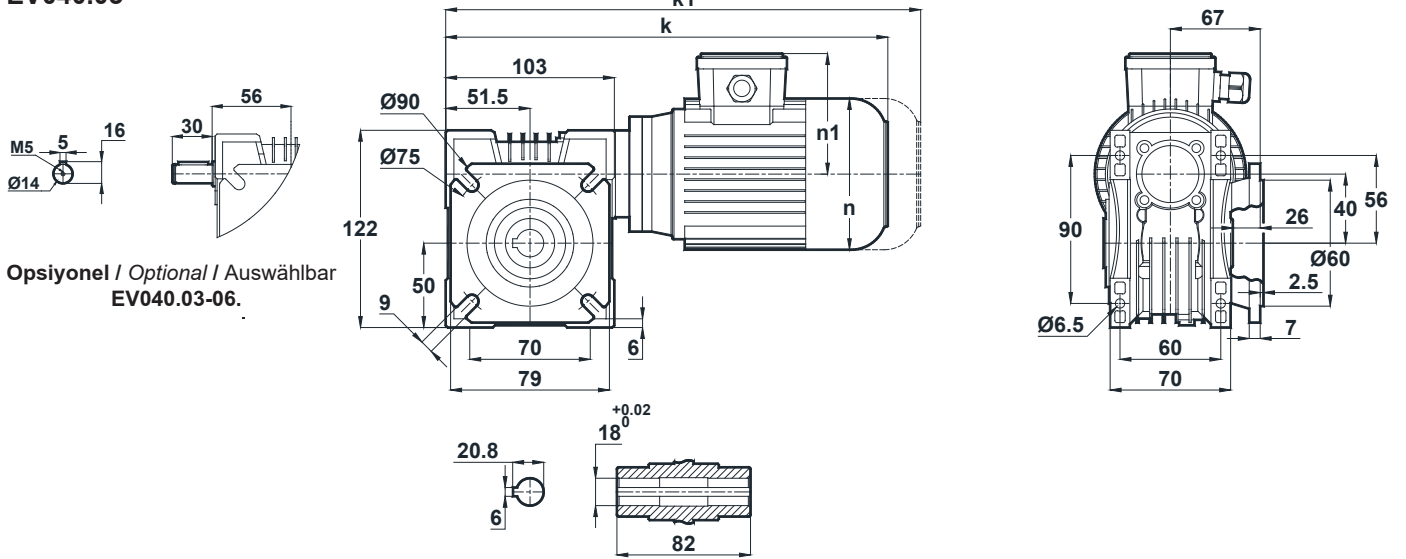

Klemens Pozisyonları / Terminal Box Positions / Klemmenkasten

IEC B14	63	71
k	321	347
k1	374	467
n	121	138
n1	97	110

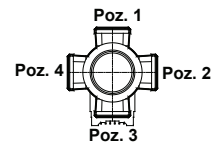

63-71  
Tip / Type / Typ

Motorlar B14 flanş ile bağlanmıştır. / Motor connections are with IEC B14 Flange / Motor Befestigung mit IEC B14 Flansch.

"k1" Ölçüsü frenli redüktörlere aittir. 56,63,71 tip elektrik motorlu redüktörler soğutmasız, diğerleri soğutmalıdır.

Dimensions "k1" is for motors with brake. Gearboxes with 56,63,71 type electrical motors are not fan cooled, other types are fan cooled.

Maße "k1" sind für Bremsenmotoren. Getrieben mit 56,63,71 Motortypen sind ohne Kühlung, andere Typen sind mit Ventilator gekühlt.



# Ölçü Sayfaları Dimension Pages Abmessungsseiten

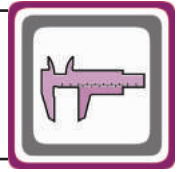

-Mil ucu çekirme deliği DIN 332 sayfa 2 / Tapped center hole to DIN 332, sheet 2 / Zentrierung mit Gewinde DIN 332, Blatt 2

## EV040.04

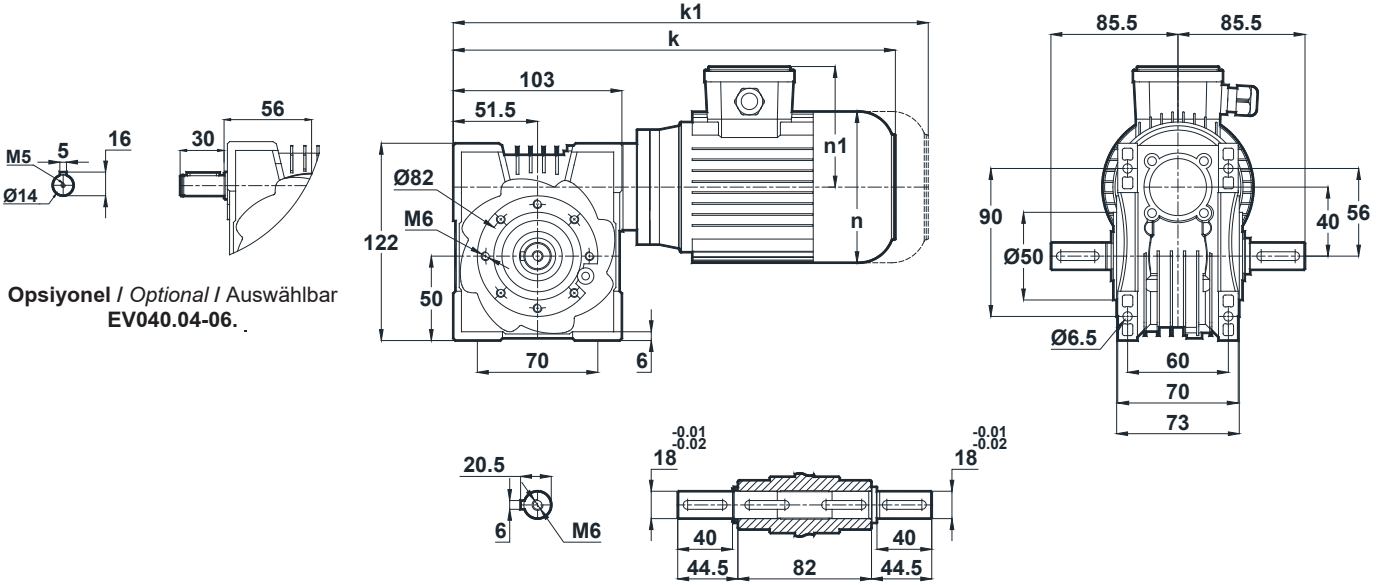

Opsiyonel / Optional / Auswählbar  
EV040.04-06.

## EV040.05

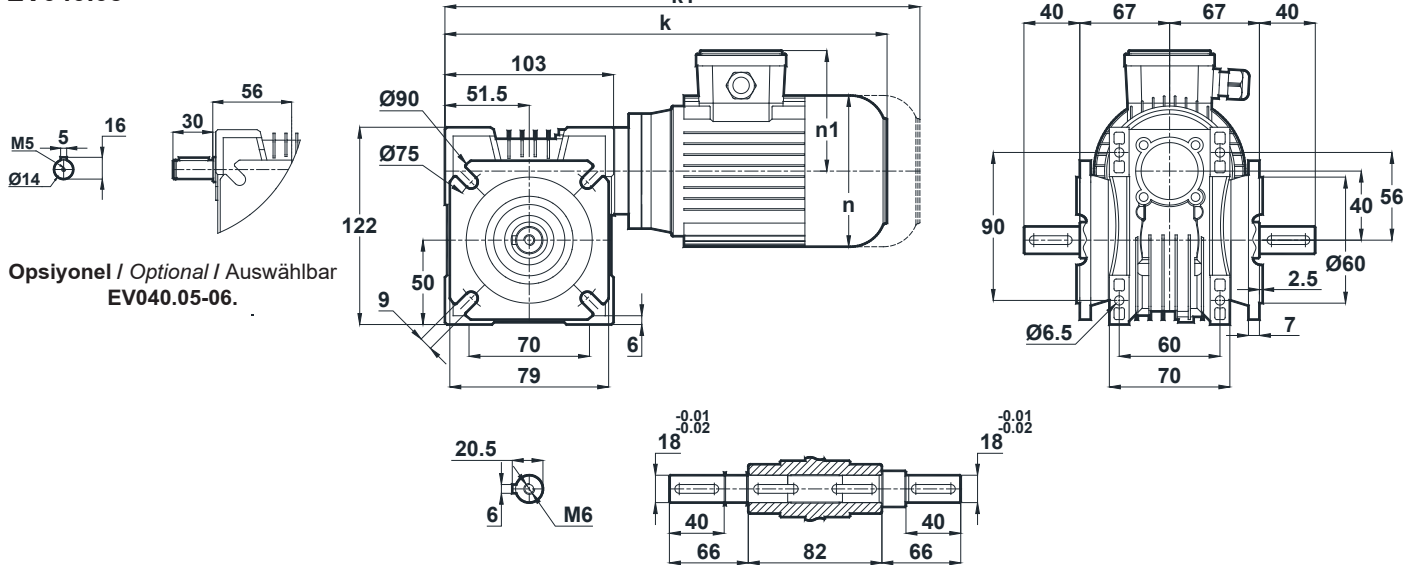

Opsiyonel / Optional / Auswählbar  
EV040.05-06.

IEC B14	63	71
k	321	347
k1	374	467
n	121	138
n1	97	110

Klemens Pozisyonları / Terminal Box Positions / Klemmenkasten

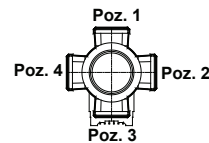

63-71  
Tip / Type / Typ

Motorlar B14 flanş ile bağlanmıştır. / Motor connections are with IEC B14 Flange / Motor Befestigung mit IEC B14 Flansch.  
"k1" Ölçüsü frenli redüktörlere aittir. 56,63,71 tip elektrik motorlu redüktörler soğutmasız, diğerleri soğutmalıdır.  
Dimensions "k1" is for motors with brake. Gearboxes with 56,63,71 type electrical motors are not fan cooled, other types are fan cooled.  
Maße "k1" ist für Bremsenmotoren. Getrieben mit 56,63,71 typ Motoren sind ohne Kühlung, andere Typen zind mit Ventilator gekühlt.



# Ölçü Sayfaları

## Dimension Pages

### Abmessungsseiten

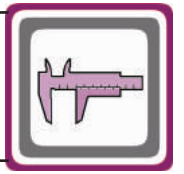

-Mil ucu çekirme deliği DIN 332 sayfa 2 / Tapped center hole to DIN 332, sheet 2 / Zentrierung mit Gewinde DIN 332, Blatt 2

EV040.08

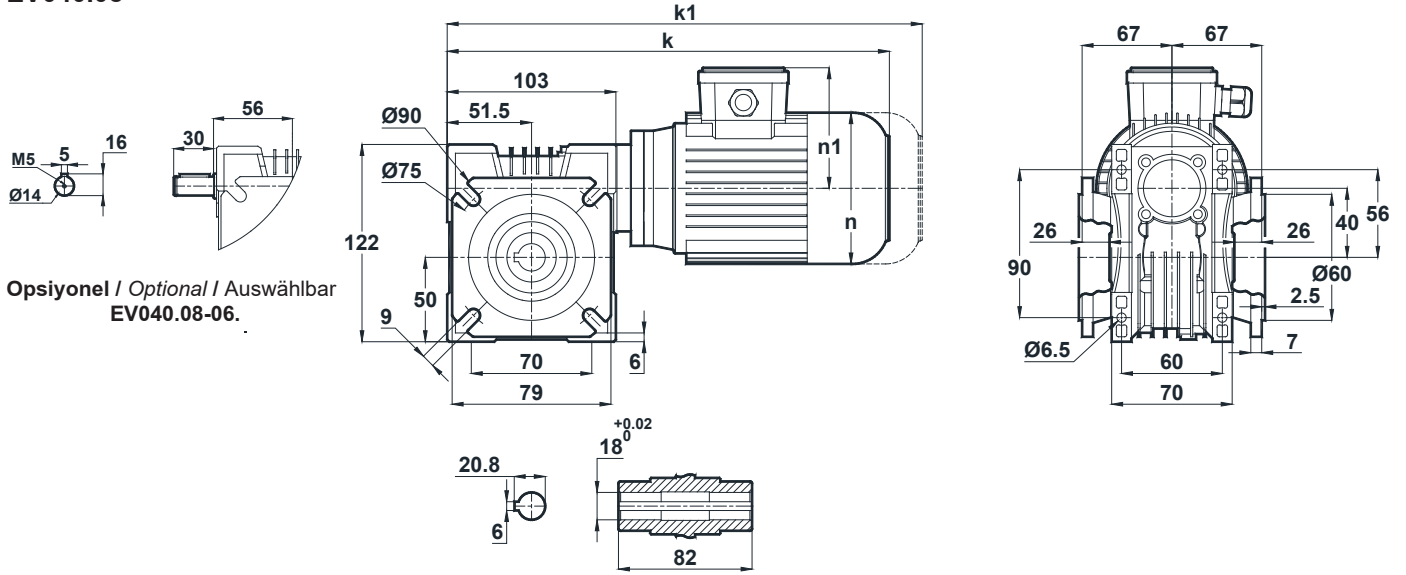

Opsiyonel / Optional / Auswählbar  
EV040.08-06.

IEC B14	63	71
k	321	347
k1	374	467
n	121	138
n1	97	110

Klemens Pozisyonları / Terminal Box Positions / Klemmenkasten

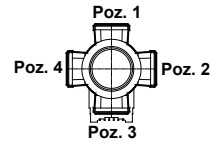

63-71  
Tip / Type / Typ

Motorlar B14 flanş ile bağlanmıştır. / Motor connections are with IEC B14 Flange / Motor Befestigung mit IEC B14 Flansch.

"k1" Ölçüsü frenli redüktörlere aittir. 56,63,71 tip elektrik motorlu redüktörler soğutmasız, diğerleri soğutmalıdır.

Dimensions "k1" is for motors with brake. Gearboxes with 56,63,71 type electrical motors are not fan cooled, other types are fan cooled.

Maße "k1" sind für Bremsenmotoren. Getrieben mit 56,63,71 Motortypen sind ohne Kühlung, andere Typen sind mit Ventilator gekühlt.



# Ölçü Sayfaları Dimension Pages Abmessungsseiten

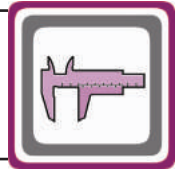

-Mil ucu çekirme deliği DIN 332 sayfa 2 / Tapped center hole to DIN 332, sheet 2 / Zentrierung mit Gewinde DIN 332, Blatt 2

## EV050.00

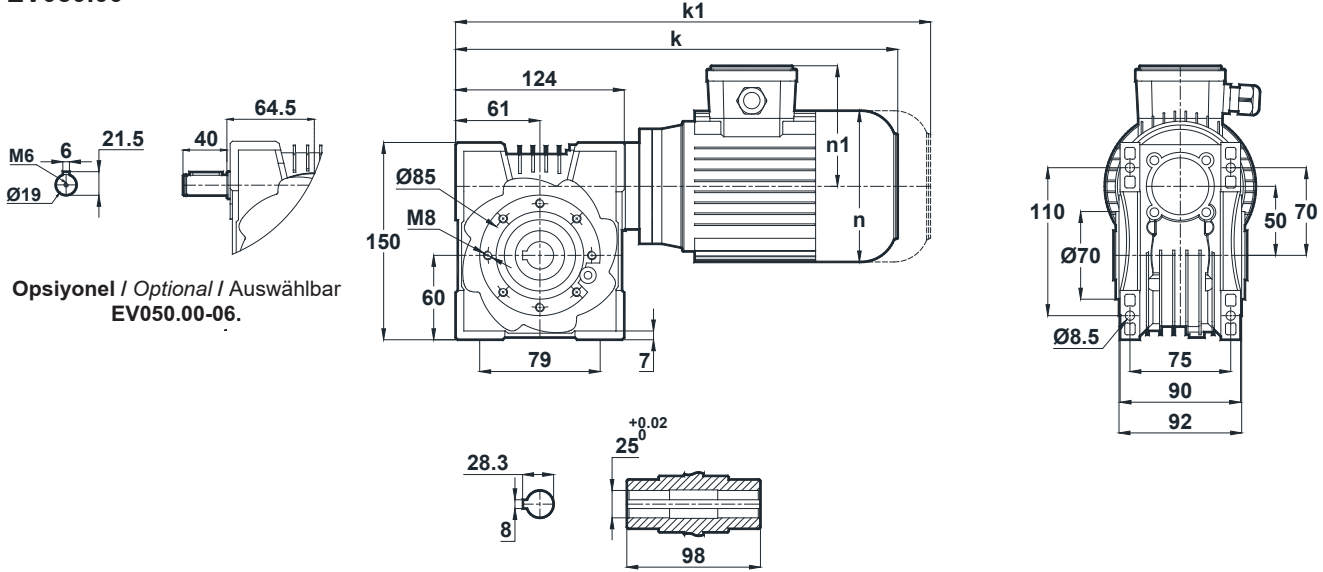

Opsiyonel / Optional / Auswählbar  
EV050.00-06.

## EV050.01

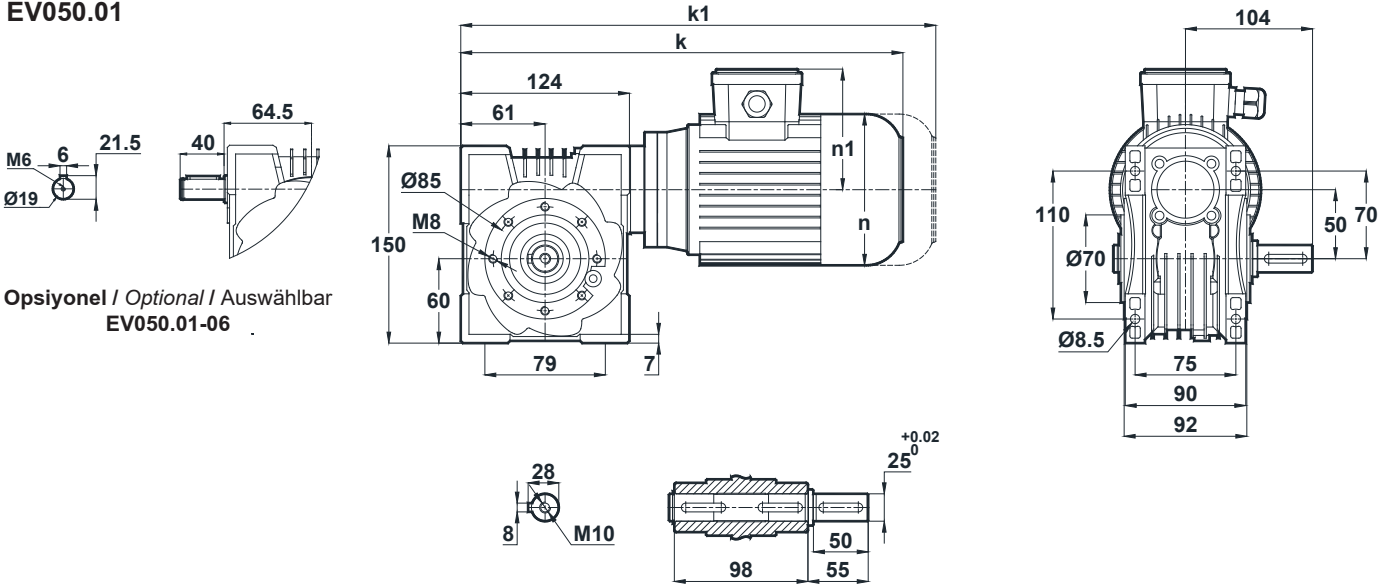

Opsiyonel / Optional / Auswählbar  
EV050.01-06

IEC B14	63	71	80	90S	90L
k	342	368	388	408	433
k1	395	488	508	533	558
n	121	138	156	176	176
n1	97	110	97	110	118

Klemens Pozisyonları / Terminal Box Positions / Klemmenkasten

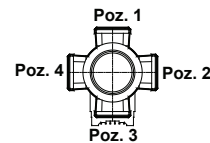

63-71-80-90  
Tip / Type / Typ

Motorlar B14 flanş ile bağlanmıştır. / Motor connections are with IEC B14 Flange / Motor Befestigung mit IEC B14 Flansch.  
"k1" Ölçüsü frenli redüktörlere aittir. 56,63,71 tip elektrik motorlu redüktörler soğutmasız, diğerleri soğutmalıdır.  
Dimensions "k1" is for motors with brake. Gearboxes with 56,63,71 type electrical motors are not fan cooled, other types are fan cooled.  
Maße "k1" ist für Bremsmotoren. Getrieben mit 56,63,71 typ Motoren sind ohne Kühlung, andere Typen sind mit Ventilator gekühlt.





# Ölçü Sayfaları Dimension Pages Abmessungsseiten

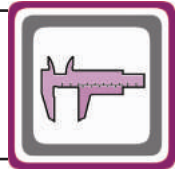

-Mil ucu çekirme deliği DIN 332 sayfa 2 / Tapped center hole to DIN 332, sheet 2 / Zentrierung mit Gewinde DIN 332, Blatt 2

## EV050.04

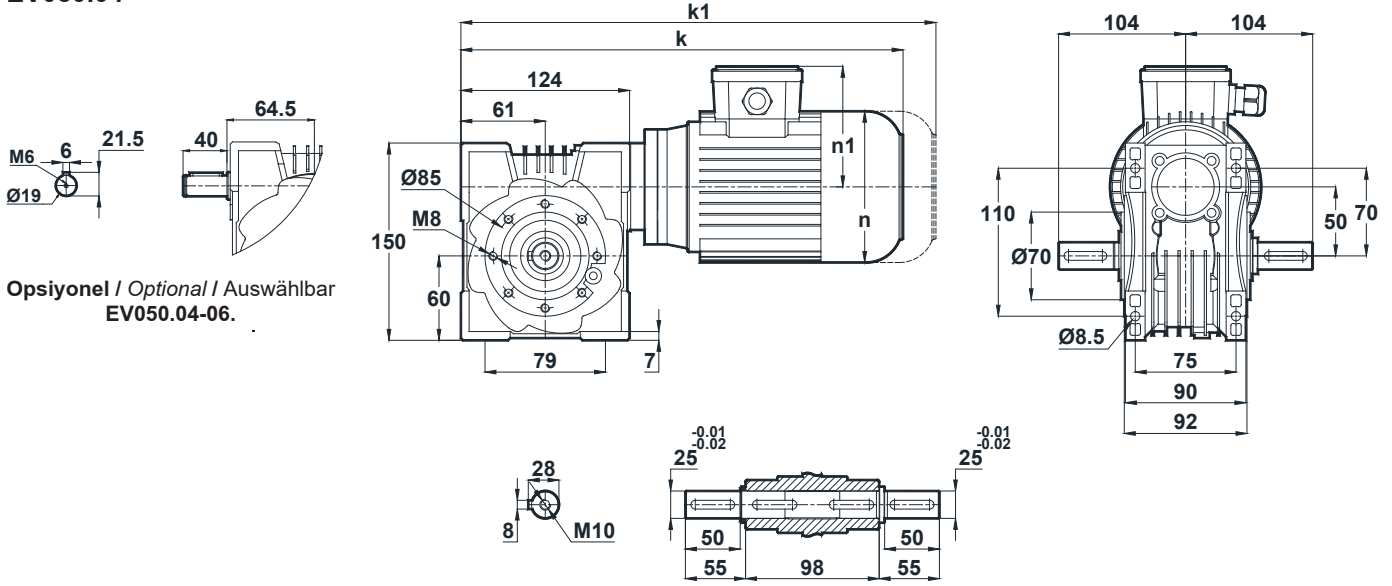

## EV050.05

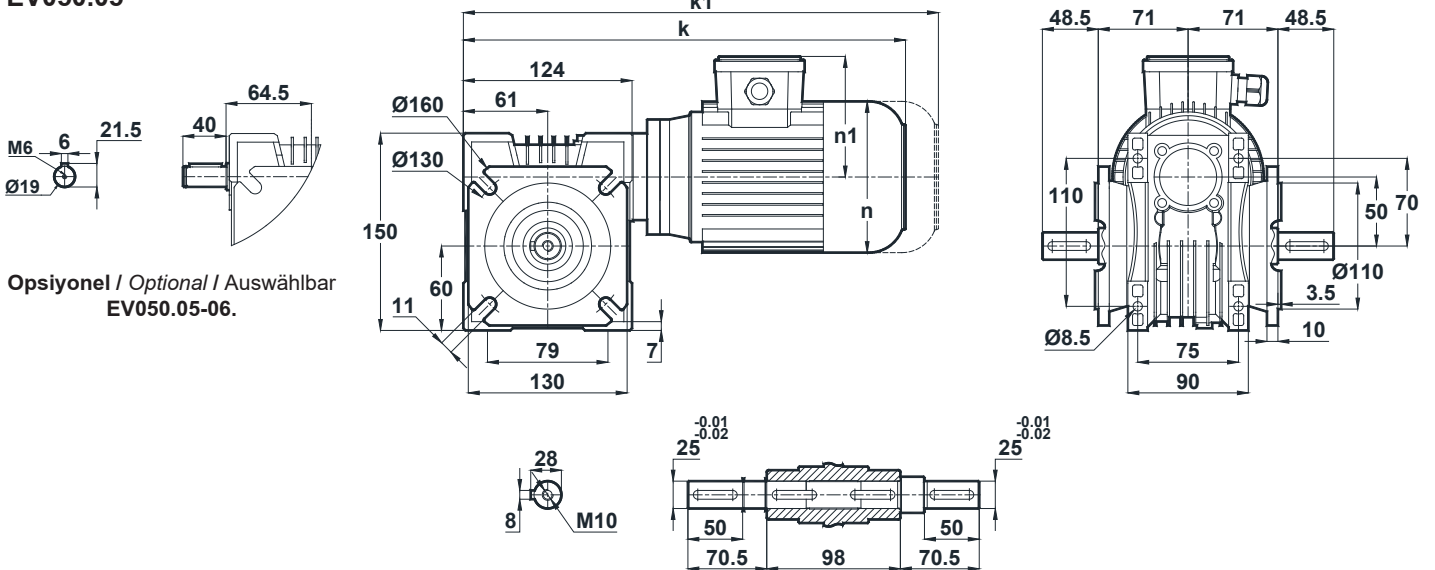

IEC B14	63	71	80	90S	90L
k	342	368	388	408	433
k1	395	488	508	533	558
n	121	138	156	176	176
n1	97	110	97	110	118

Klemens Pozisyonları / Terminal Box Positions / Klemmenkasten

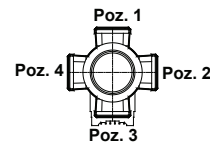

63-71-80-90  
Tip / Type / Typ

Motorlar B14 flanş ile bağlanmıştır. / Motor connections are with IEC B14 Flange / Motor Befestigung mit IEC B14 Flansch.  
"k1" Ölçüsü frenli redüktörlere aittir. 56,63,71 tip elektrik motorlu redüktörler soğutmasız, diğerleri soğutmalıdır.  
Dimensions "k1" is for motors with brake. Gearboxes with 56,63,71 type electrical motors are not fan cooled, other types are fan cooled.  
Maße "k1" ist für Bremsenmotoren. Getrieben mit 56,63,71 typ Motoren sind ohne Kühlung, andere Typen zind mit Ventilator gekühlt.

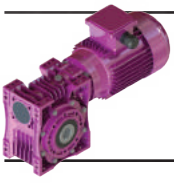

# Ölçü Sayfaları Dimension Pages Abmessungsseiten

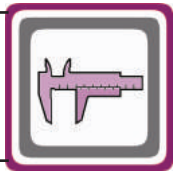

-Mil ucu çekirme deliği DIN 332 sayfa 2 / Tapped center hole to DIN 332, sheet 2 / Zentrierung mit Gewinde DIN 332, Blatt 2

EV050.08

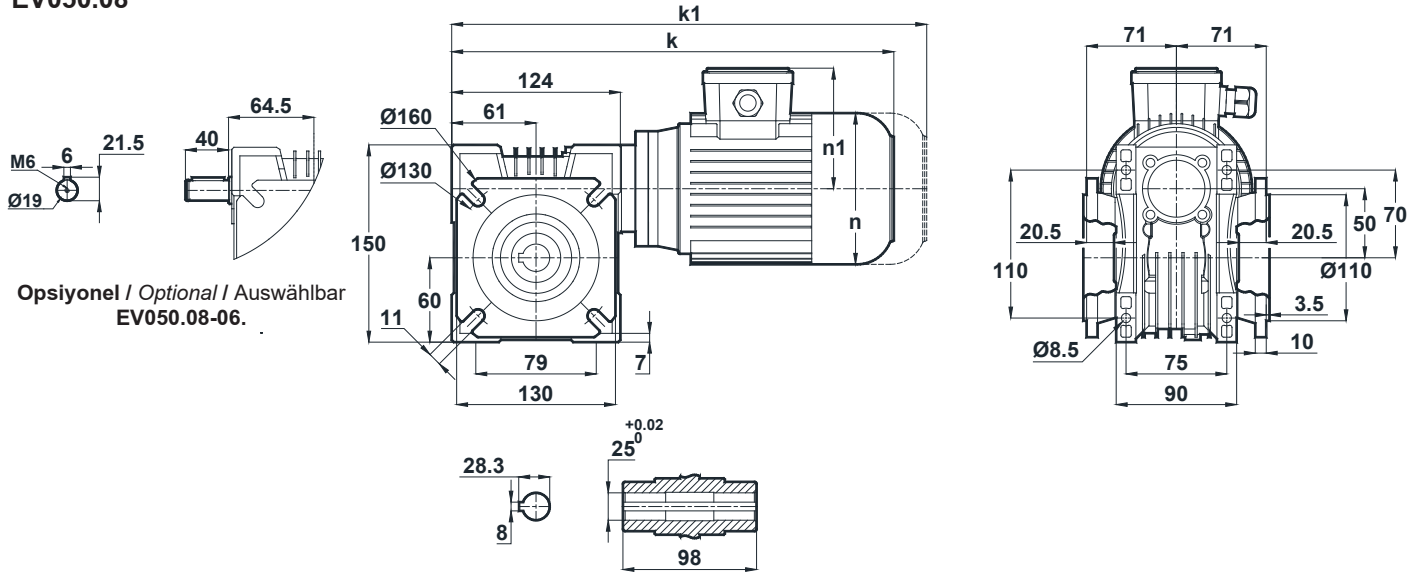

Opsiyonel / Optional / Auswählbar  
EV050.08-06.

IEC B14	63	71	80	90S	90L
k	342	368	388	408	433
k1	395	488	508	533	558
n	121	138	156	176	176
n1	97	110	97	110	118

Klemens Pozisyonları / Terminal Box Positions / Klemmenkasten

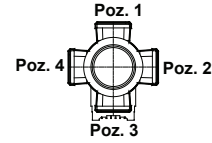

63-71-80-90  
Tip / Type / Typ

Motorlar B14 flanş ile bağlanmıştır. / Motor connections are with IEC B14 Flange / Motor Befestigung mit IEC B14 Flansch.

"k1" Ölçüsü frenli redüktörlere aittir. 56,63,71 tip elektrik motorlu redüktörler soğutmasız, diğerleri soğutmalıdır.

Dimensions "k1" is for motors with brake. Gearboxes with 56,63,71 type electrical motors are not fan cooled, other types are fan cooled.

Maße "k1" sind für Bremsenmotoren. Getrieben mit 56,63,71 Motortypen sind ohne Kühlung, andere Typen sind mit Ventilator gekühlt.



# Ölçü Sayfaları Dimension Pages Abmessungsseiten

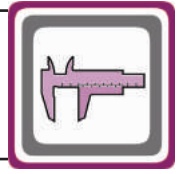

-Mil ucu çekirme deliği DIN 332 sayfa 2 / Tapped center hole to DIN 332, sheet 2 / Zentrierung mit Gewinde DIN 332, Blatt 2

## EV063.00

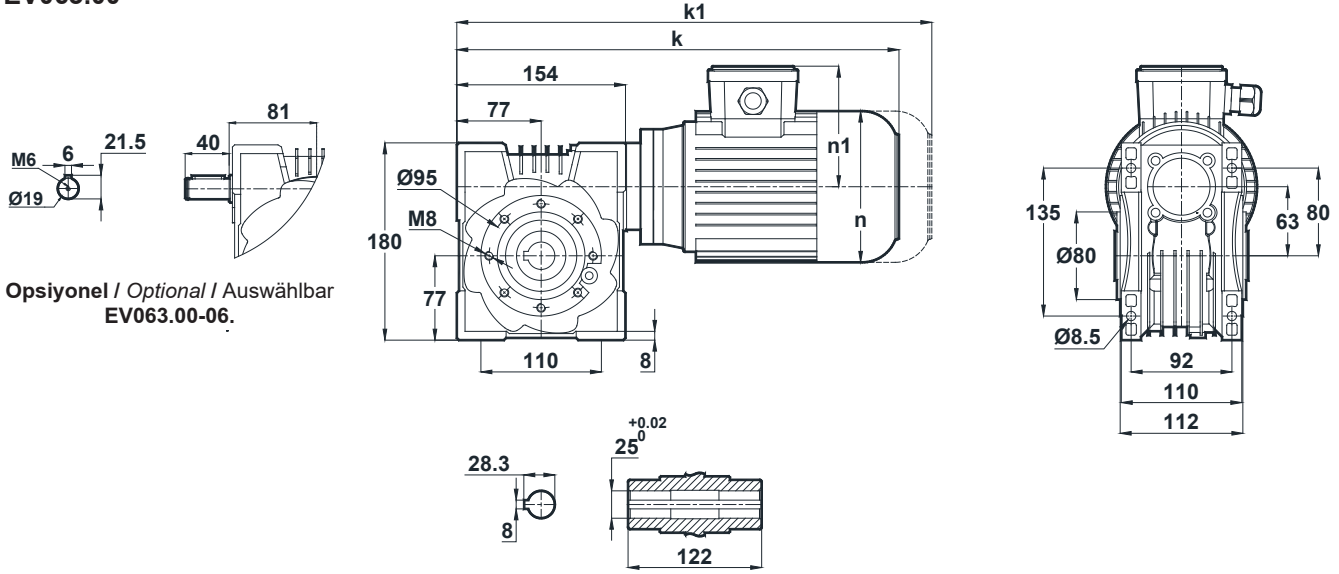

## EV063.01

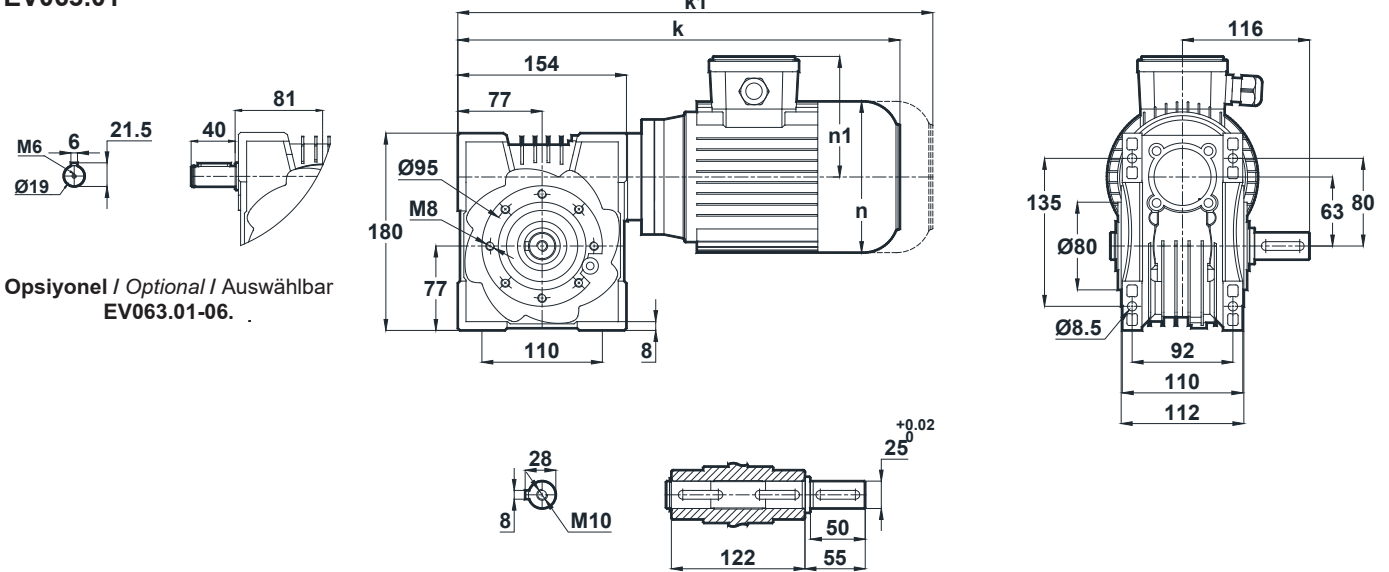

IEC B14	71	80	90S	90L
k	398	418	438	463
k1	518	538	563	588
n	138	156	176	176
n1	110	118	126	126

Klemens Pozisyonları / Terminal Box Positions / Klemmenkasten

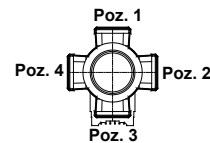

71-80-90  
Tip / Type / Typ

Motorlar B14 flanş ile bağlanmıştır. / Motor connections are with IEC B14 Flange / Motor Befestigung mit IEC B14 Flansch.  
"k1" Ölçüsü frenli redüktörlere aittir. 56,63,71 tip elektrik motorlu redüktörler soğutmasız, diğerleri soğutmalıdır.  
Dimensions "k1" is for motors with brake. Gearboxes with 56,63,71 type electrical motors are not fan cooled, other types are fan cooled.  
Maße "k1" ist für Bremsenmotoren. Getrieben mit 56,63,71 typ Motoren sind ohne Kühlung, andere Typen zind mit Ventilator gekühlt.







# Ölçü Sayfaları Dimension Pages Abmessungenseiten

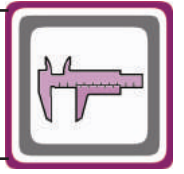

-Mil ucu çekirme deliği DIN 332 sayfa 2 / Tapped center hole to DIN 332, sheet 2 / Zentrierung mit Gewinde DIN 332, Blatt 2  
EV063.08

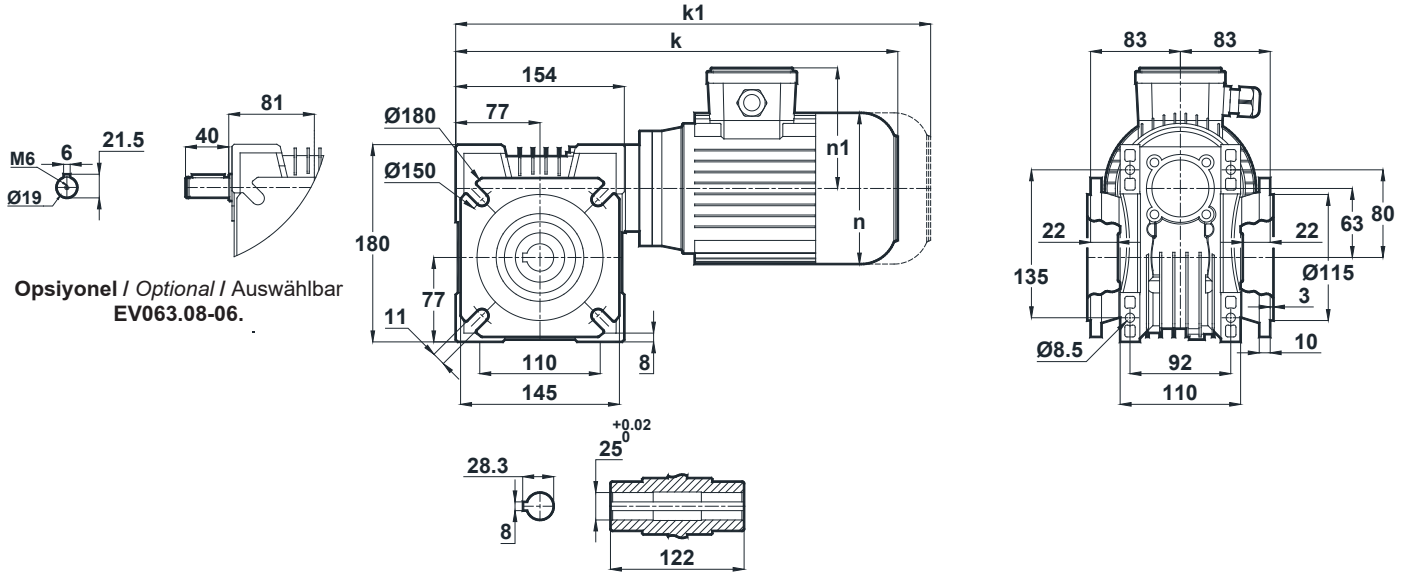

Opsiyonel / Optional / Auswählbar  
EV063.08-06.

IEC B14	71	80	90S	90L
k	398	418	438	463
k1	518	538	563	588
n	138	156	176	176
n1	110	118	126	126

Klemens Pozisyonları / Terminal Box Positions / Klemmenkasten

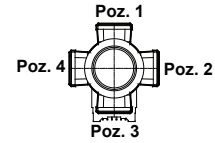

71-80-90  
Tip / Type / Typ

Motorlar B14 flanş ile bağlanmıştır. / Motor connections are with IEC B14 Flange / Motor Befestigung mit IEC B14 Flansch.

"k1" Ölçüsü frenli redüktörlere aittir. 56,63,71 tip elektrik motorlu redüktörler soğutmasız, diğerleri soğutmalıdır.

Dimensions "k1" is for motors with brake. Gearboxes with 56,63,71 type electrical motors are not fan cooled, other types are fan cooled.

Maße "k1" sind für Bremsenmotoren. Getrieben mit 56,63,71 Motortypen sind ohne Kühlung, andere Typen sind mit Ventilator gekühlt.



# Ölçü Sayfaları Dimension Pages Abmessungsseiten

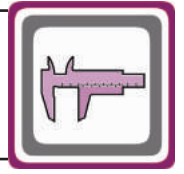

-Mil ucu çekirme deliği DIN 332 sayfa 2 / Tapped center hole to DIN 332, sheet 2 / Zentrierung mit Gewinde DIN 332, Blatt 2

## EV075.00

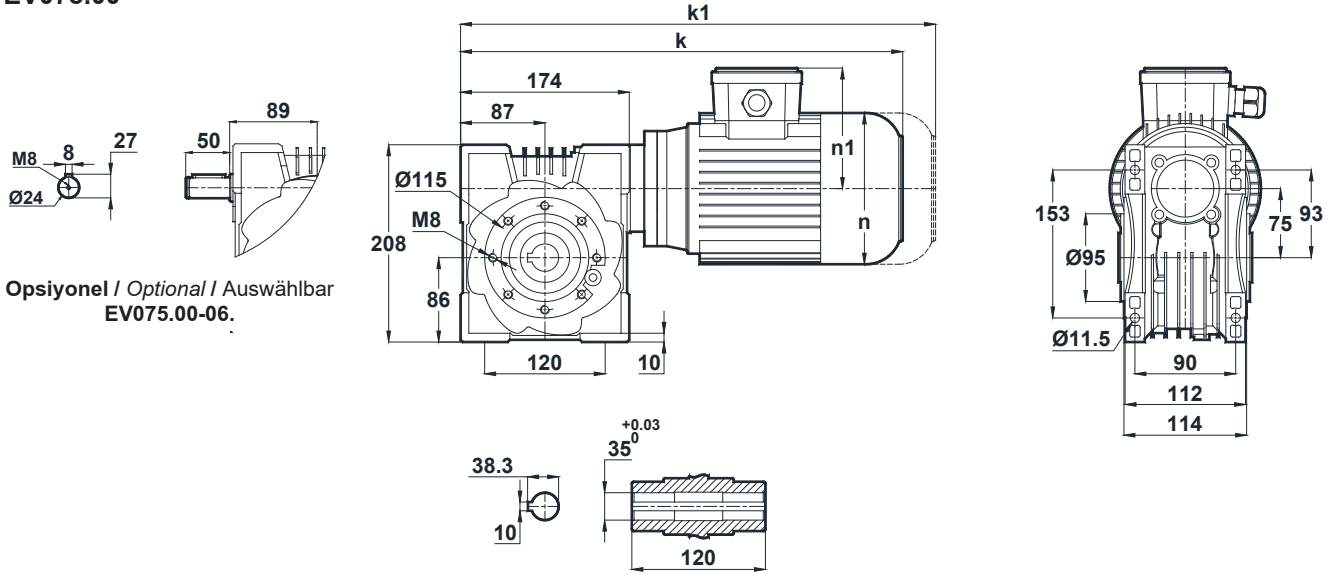

## EV075.01

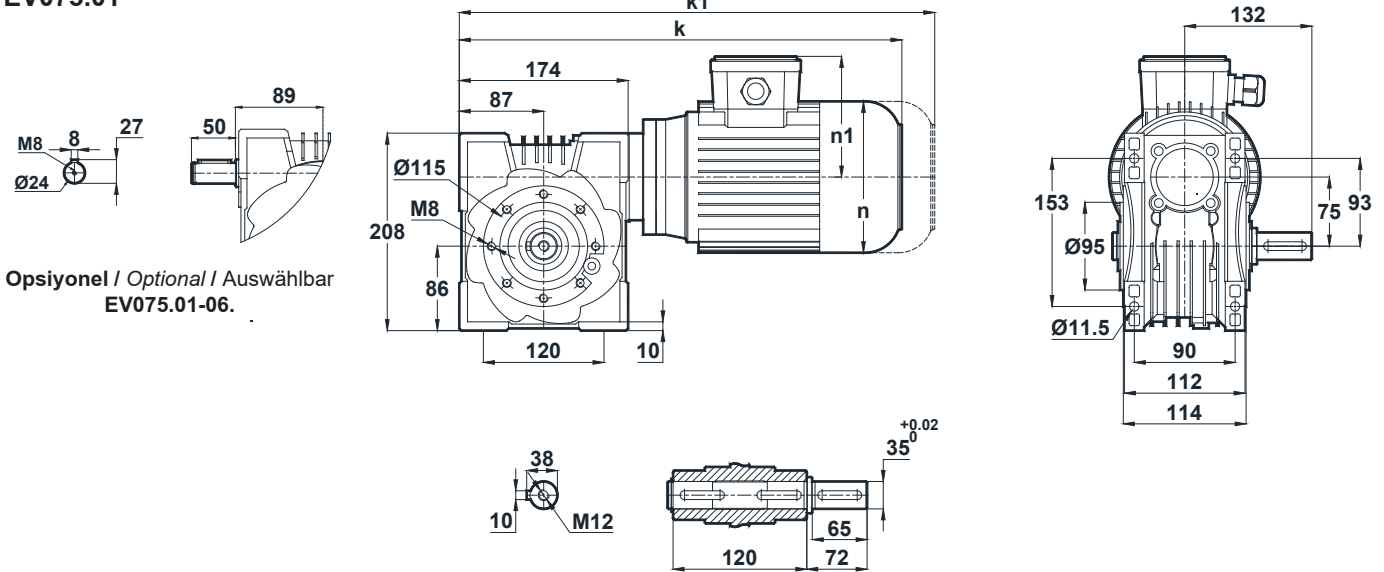

IEC B14	80	90S	90L	100L	112M
k	439,5	459,5	484,5	516,5	536,5
k1	559,5	584,5	609,5	651,5	671,5
n	156	176	176	194	218
n1	118	126	126	135	146

### Klemens Pozisyonları / Terminal Box Positions / Klemmenkasten

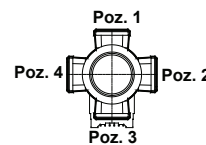

90-100-112  
Tip / Type / Typ

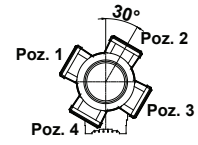

80  
Tip / Type / Typ

Motorlar B14 flanş ile bağlanmıştır. / Motor connections are with IEC B14 Flange / Motor Befestigung mit IEC B14 Flansch.  
"k1" Ölçüsü frenli redüktörlere aittir. 56,63,71 tip elektrik motorlu redüktörler soğutmasız, diğerleri soğutmalıdır.  
Dimensions "k1" is for motors with brake. Gearboxes with 56,63,71 type electrical motors are not fan cooled, other types are fan cooled.  
Maße "k1" ist für Bremsenmotoren. Getrieben mit 56,63,71 typ Motoren sind ohne Kühlung, andere Typen zind mit Ventilator gekühlt.

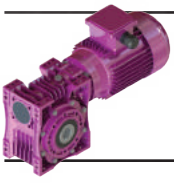

# Ölçü Sayfaları Dimension Pages Abmessungsseiten

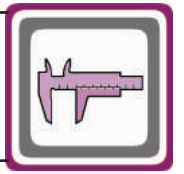

-Mil ucu çekirme deliği DIN 332 sayfa 2 / Tapped center hole to DIN 332, sheet 2 / Zentrierung mit Gewinde DIN 332, Blatt 2

## EV075.02

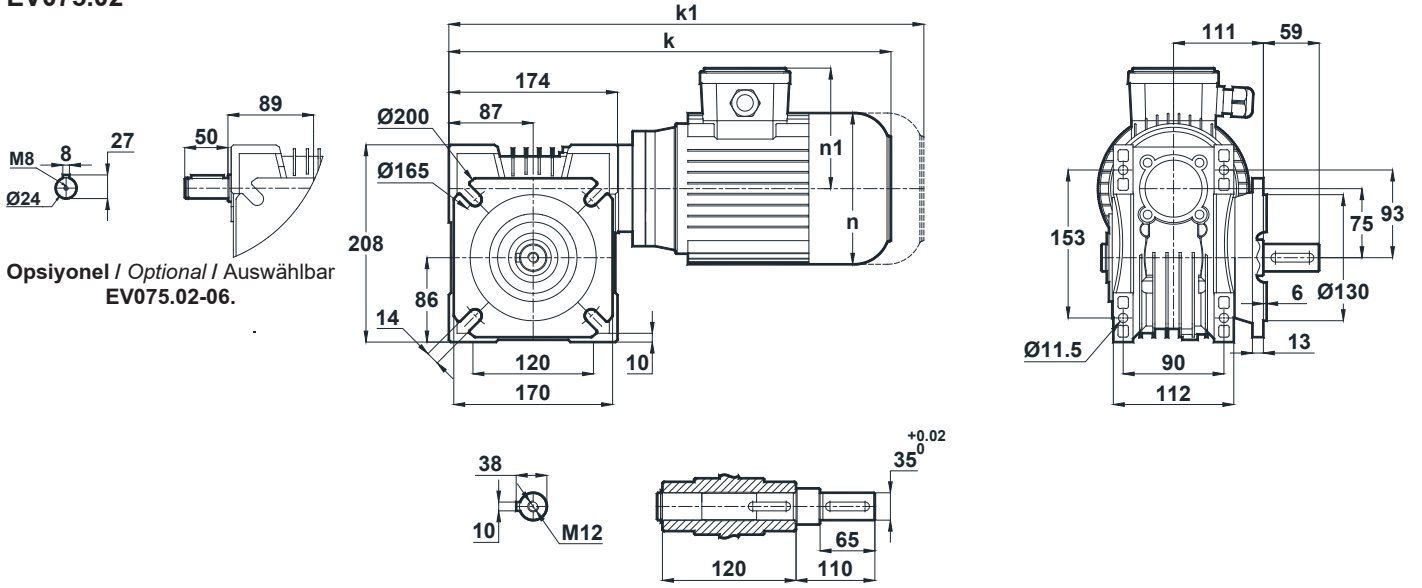

## EV075.03

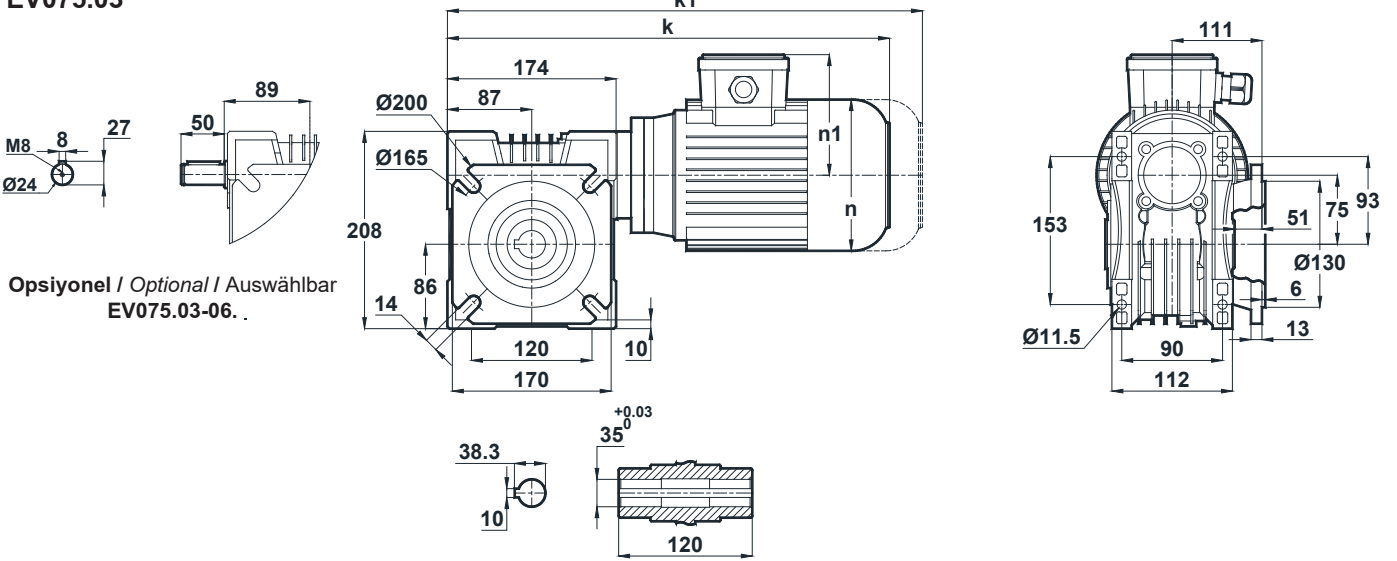

IEC B14	80	90S	90L	100L	112M
k	439,5	459,5	484,5	516,5	536,5
k1	559,5	584,5	609,5	651,5	671,5
n	156	176	176	194	218
n1	118	126	126	135	146

### Klemens Pozisyonları / Terminal Box Positions / Klemmenkasten

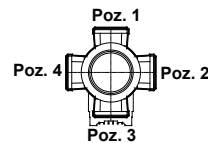

90-100-112  
Tip / Type / Typ

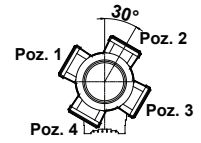

80  
Tip / Type / Typ

Motorlar B14 flanş ile bağlanmıştır. / Motor connections are with IEC B14 Flange / Motor Befestigung mit IEC B14 Flansch.

"k1" Ölçüsü frenli redüktörlere aittir. 56,63,71 tip elektrik motorlu redüktörler soğutmasız, diğerleri soğutmalıdır.

Dimensions "k1" is for motors with brake. Gearboxes with 56,63,71 type electrical motors are not fan cooled, other types are fan cooled.

Maße "k1" sind für Bremsenmotoren. Getrieben mit 56,63,71 Motortypen sind ohne Kühlung, andere Typen sind mit Ventilator gekühlt.



# Ölçü Sayfaları Dimension Pages Abmessungsseiten

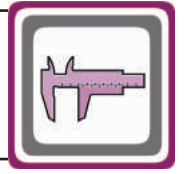

-Mil ucu çektirme deliği DIN 332 sayfa 2 / Tapped center hole to DIN 332, sheet 2 / Zentrierung mit Gewinde DIN 332, Blatt 2

## EV075.04

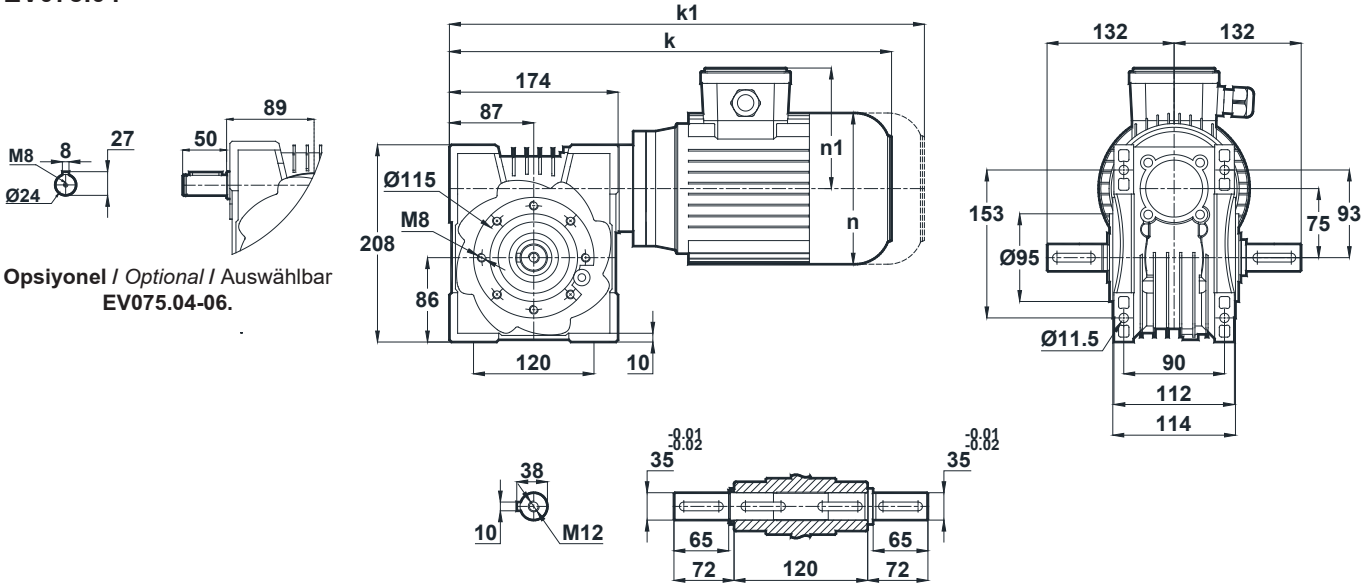

## EV075.05

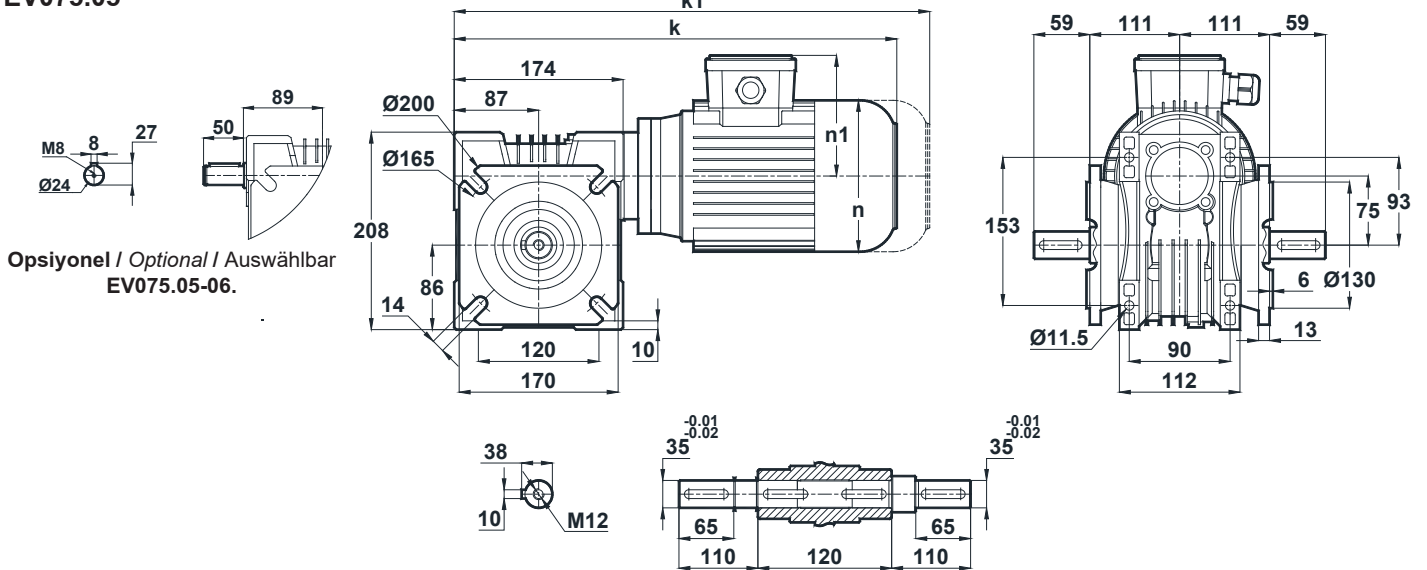

IEC B14	80	90S	90L	100L	112M
k	439,5	459,5	484,5	516,5	536,5
k1	559,5	584,5	609,5	651,5	671,5
n	156	176	176	194	218
n1	118	126	126	135	146

### Klemens Pozisyonları / Terminal Box Positions / Klemmenkasten

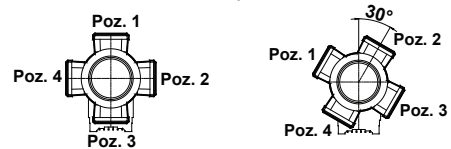

90-100-112  
Tip / Type / Typ

80  
Tip / Type / Typ

Motorlar B14 flanş ile bağlanmıştır. / Motor connections are with IEC B14 Flange / Motor Befestigung mit IEC B14 Flansch.  
"k1" Ölçüsü frenli redüktörlere aittir. 56,63,71 tip elektrik motorlu redüktörler soğutmasız, diğerleri soğutmalıdır.  
Dimensions "k1" is for motors with brake. Gearboxes with 56,63,71 type electrical motors are not fan cooled, other types are fan cooled.  
Maße "k1" ist für Bremsenmotoren. Getrieben mit 56,63,71 typ Motoren sind ohne Kühlung, andere Typen zind mit Ventilator gekühlt.



# Ölçü Sayfaları Dimension Pages Abmessungsseiten

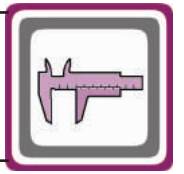

-Mil ucu çekirme deliği DIN 332 sayfa 2 / Tapped center hole to DIN 332, sheet 2 / Zentrierung mit Gewinde DIN 332, Blatt 2

EV075.08

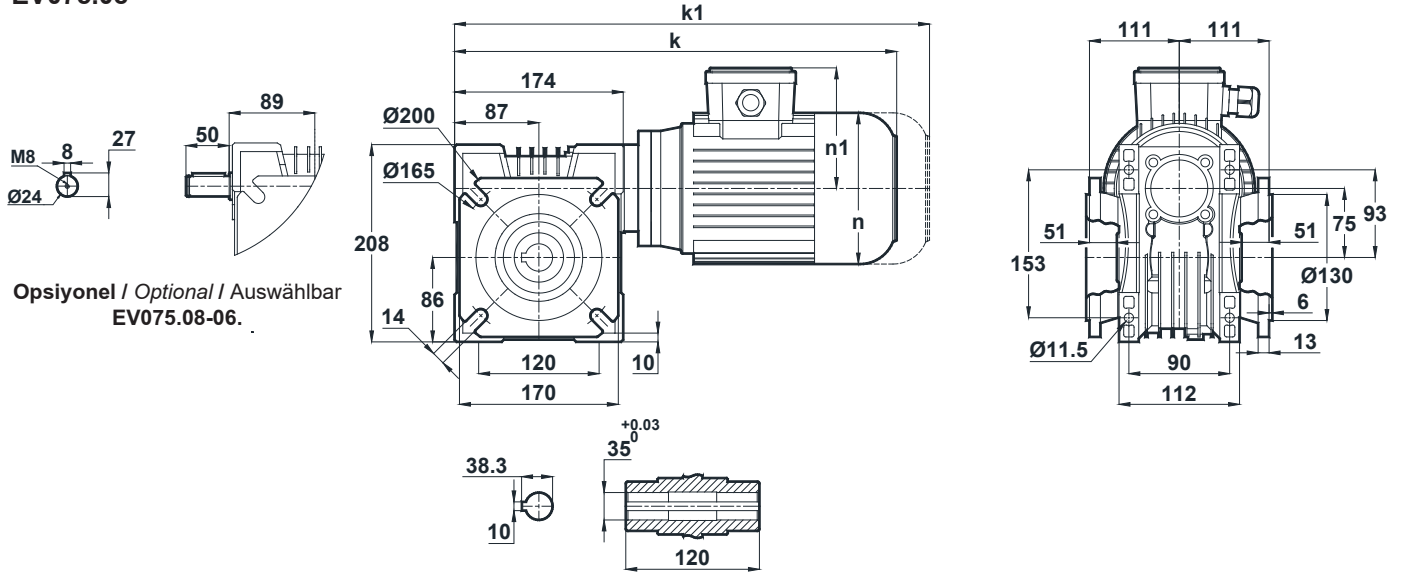

Opsiyonel / Optional / Auswählbar  
EV075.08-06.

IEC B14	80	90S	90L	100L	112M
k	439,5	459,5	484,5	516,5	536,5
k1	559,5	584,5	609,5	651,5	671,5
n	156	176	176	194	218
n1	118	126	126	135	146

Klemens Pozisyonları / Terminal Box Positions / Klemmenkasten

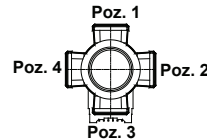

90-100-112  
Tip / Type / Typ

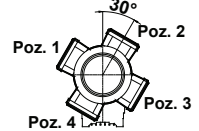

80  
Tip / Type / Typ

Motorlar B14 flanş ile bağlanmıştır. / Motor connections are with IEC B14 Flange / Motor Befestigung mit IEC B14 Flansch.

"k1" Ölçüsü frenli redüktörlere aittir. 56,63,71 tip elektrik motorlu redüktörler soğutmasız, diğerleri soğutmalıdır.

Dimensions "k1" is for motors with brake. Gearboxes with 56,63,71 type electrical motors are not fan cooled, other types are fan cooled.

Maße "k1" sind für Bremsenmotoren. Getrieben mit 56,63,71 Motortypen sind ohne Kühlung, andere Typen sind mit Ventilator gekühlt.



# Ölçü Sayfaları Dimension Pages Abmessungsseiten

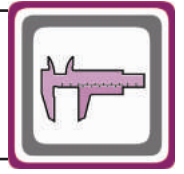

-Mil ucu çekirme deliği DIN 332 sayfa 2 / Tapped center hole to DIN 332, sheet 2 / Zentrierung mit Gewinde DIN 332, Blatt 2

## EV080.00

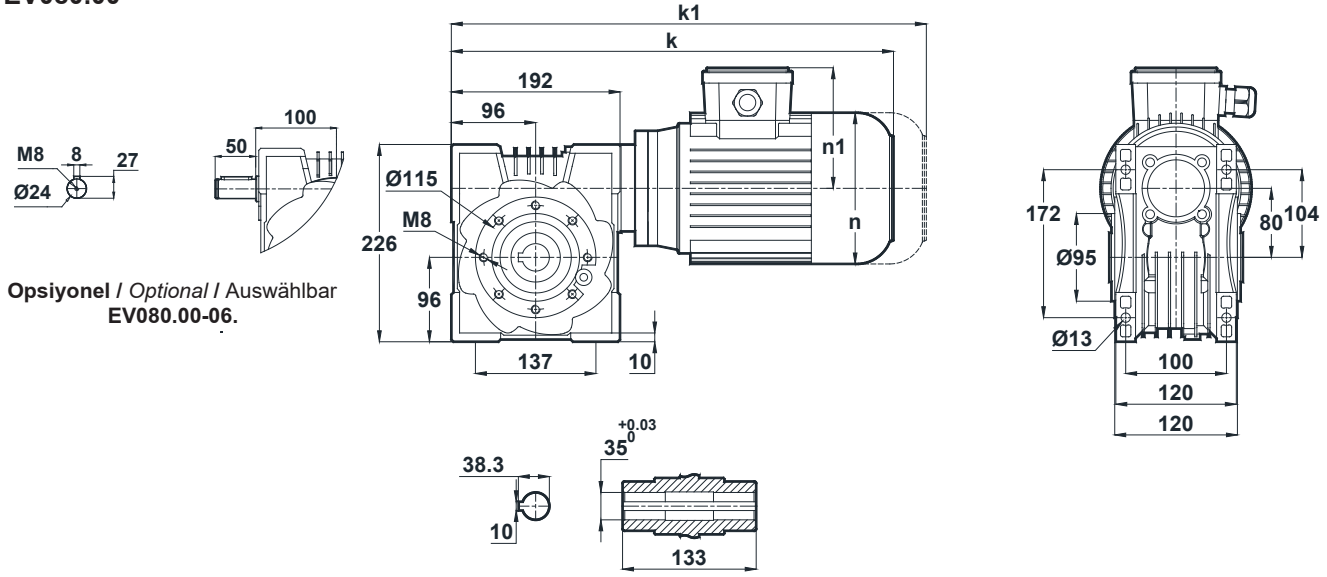

Opsiyonel / Optional / Auswählbar  
EV080.00-06.

## EV080.01

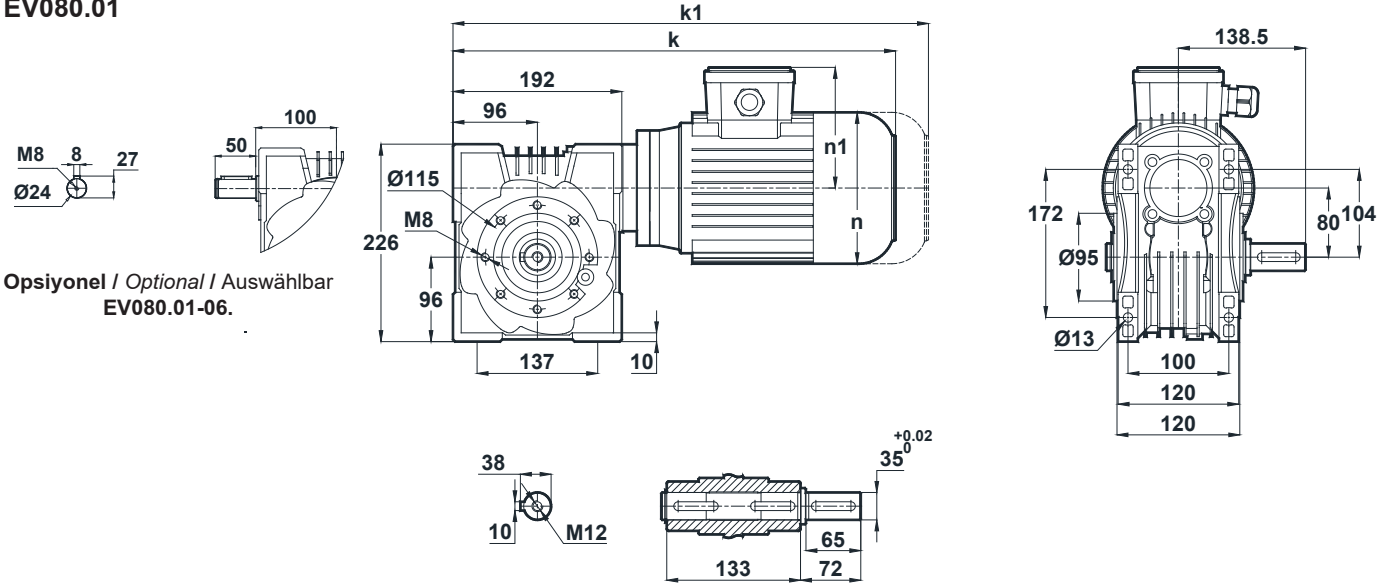

Opsiyonel / Optional / Auswählbar  
EV080.01-06.

IEC B14	80	90S	90L	100L	112M
k	457,5	477,5	502,5	534,5	554,5
k1	577,5	602,5	627,5	669,5	689,5
n	156	176	176	194	218
n1	118	126	126	135	146

Klemens Pozisyonları / Terminal Box Positions / Klemmenkasten

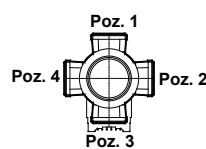

90-100-112  
Tip / Type / Typ

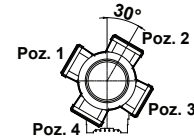

80  
Tip / Type / Typ

Motorlar B14 flanş ile bağlanmıştır. / Motor connections are with IEC B14 Flange / Motor Befestigung mit IEC B14 Flansch.  
"k1" Ölçüsü frenli redüktörlere aittir. 56,63,71 tip elektrik motorlu redüktörler soğutmasız, diğerleri soğutmalıdır.  
Dimensions "k1" is for motors with brake. Gearboxes with 56,63,71 type electrical motors are not fan cooled, other types are fan cooled.  
Maße "k1" ist für Bremsenmotoren. Getrieben mit 56,63,71 typ Motoren sind ohne Kühlung, andere Typen sind mit Ventilator gekühlt.

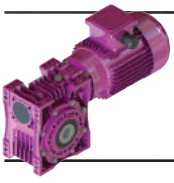

# Ölçü Sayfaları Dimension Pages Abmessungsseiten

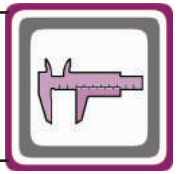

-Mil ucu çekirme deliği DIN 332 sayfa 2 / Tapped center hole to DIN 332, sheet 2 / Zentrierung mit Gewinde DIN 332, Blatt 2

## EV080.02

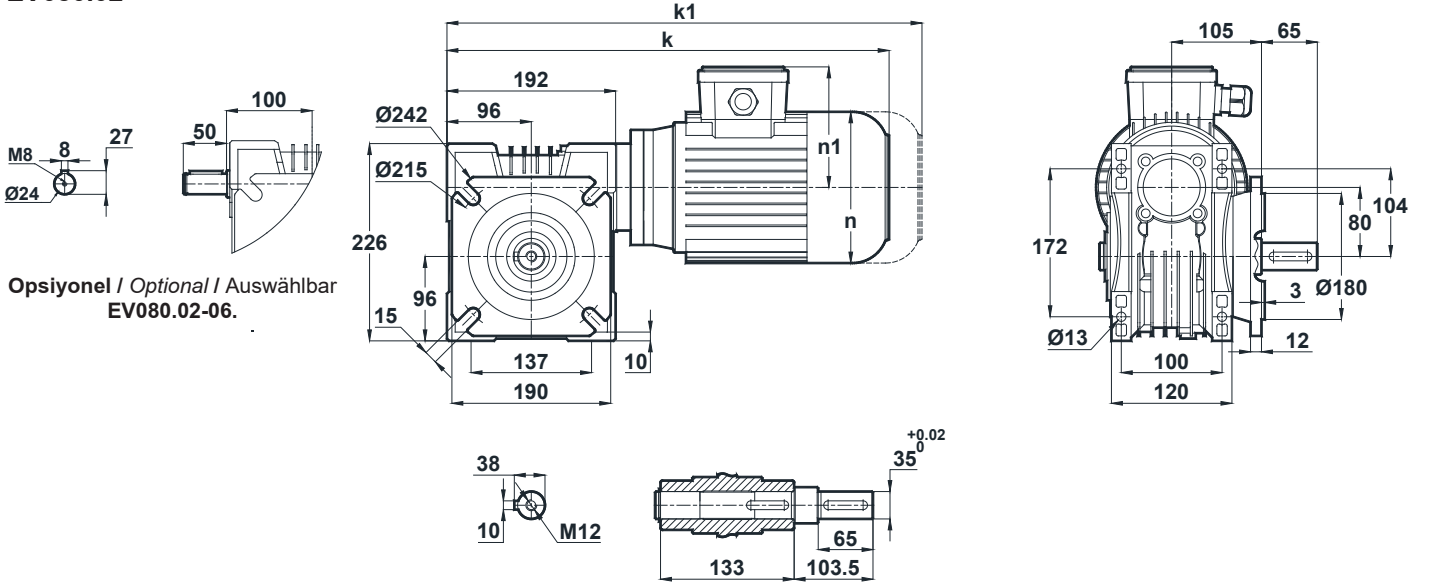

## EV080.03

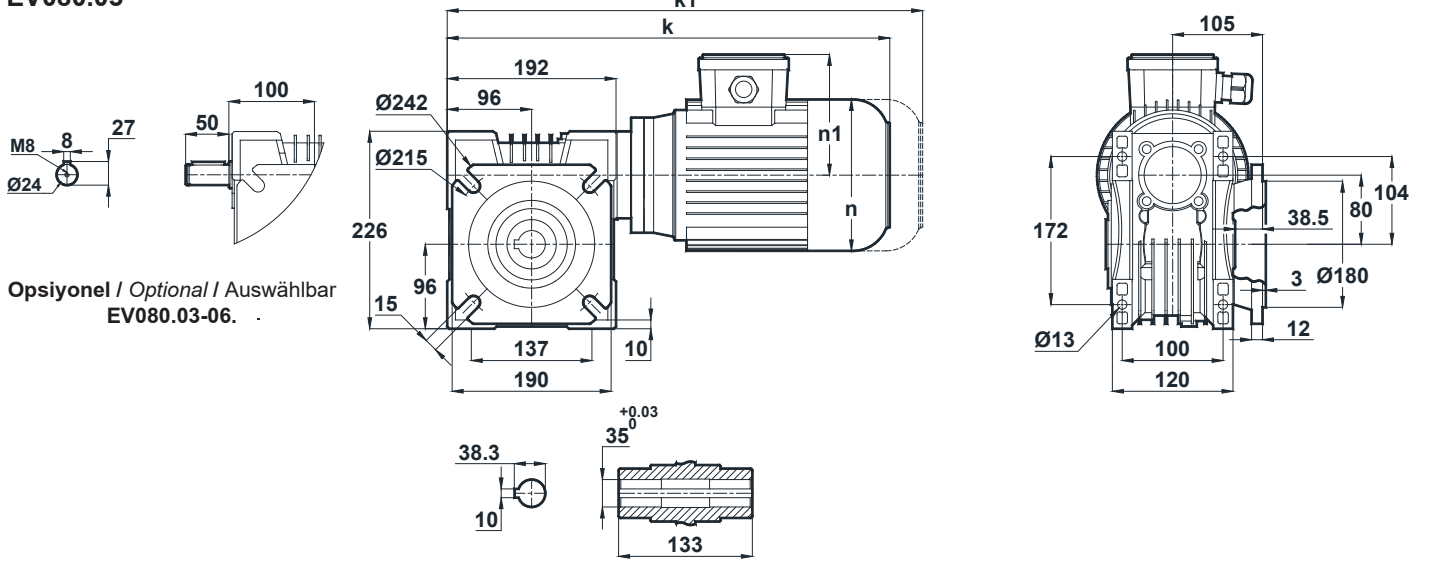

IEC B14	80	90S	90L	100L	112M
k	457,5	477,5	502,5	534,5	554,5
k1	577,5	602,5	627,5	669,5	689,5
n	156	176	176	194	218
n1	118	126	126	135	146

### Klemens Pozisyonları / Terminal Box Positions / Klemmenkasten

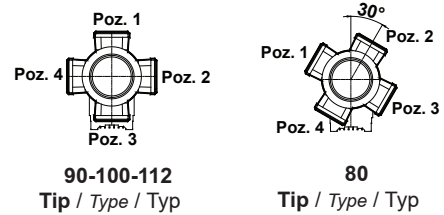

Motorlar B14 flanş ile bağlanmıştır. / Motor connections are with IEC B14 Flange / Motor Befestigung mit IEC B14 Flansch.  
"k1" Ölçüsü frenli redüktörlere aittir. 56,63,71 tip elektrik motorlu redüktörler soğutmasız, diğerleri soğutmalıdır.  
Dimensions "k1" is for motors with brake. Gearboxes with 56,63,71 type electrical motors are not fan cooled, other types are fan cooled.  
Maße "k1" sind für Bremsmotoren. Getrieben mit 56,63,71 Motortypen sind ohne Kühlung, andere Typen sind mit Ventilator gekühlt.



# Ölçü Sayfaları Dimension Pages Abmessungsseiten

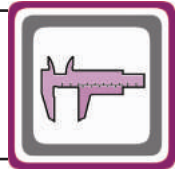

-Mil ucu çekirme deliği DIN 332 sayfa 2 / Tapped center hole to DIN 332, sheet 2 / Zentrierung mit Gewinde DIN 332, Blatt 2

## EV080.04

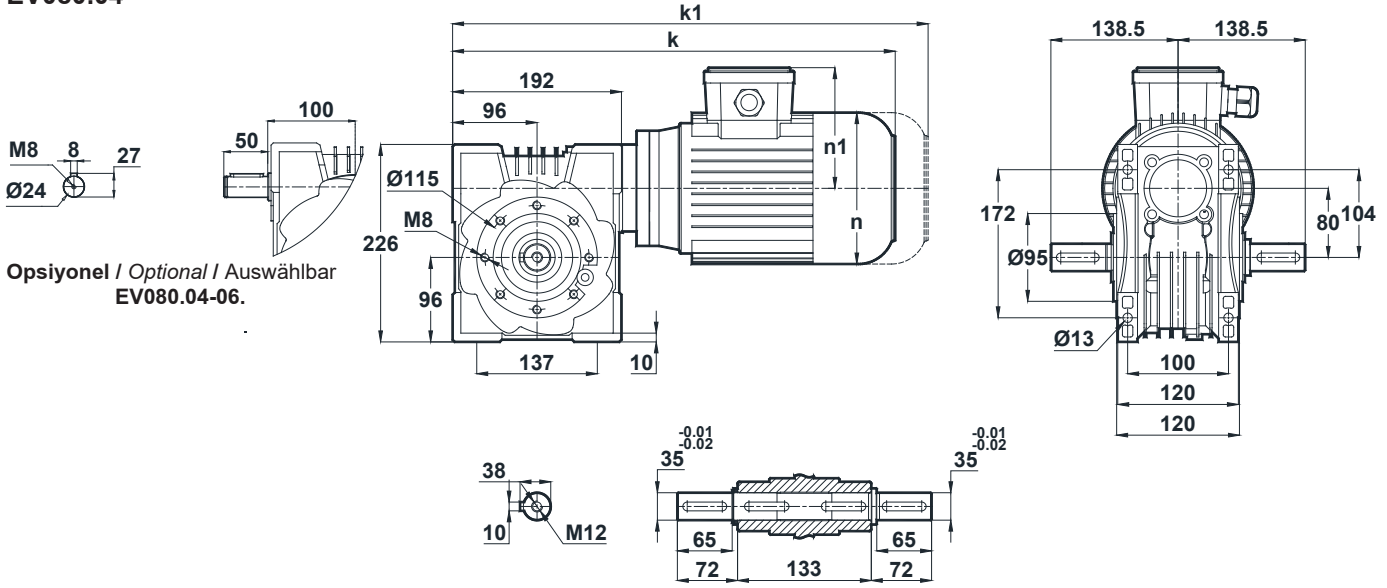

## EV080.05

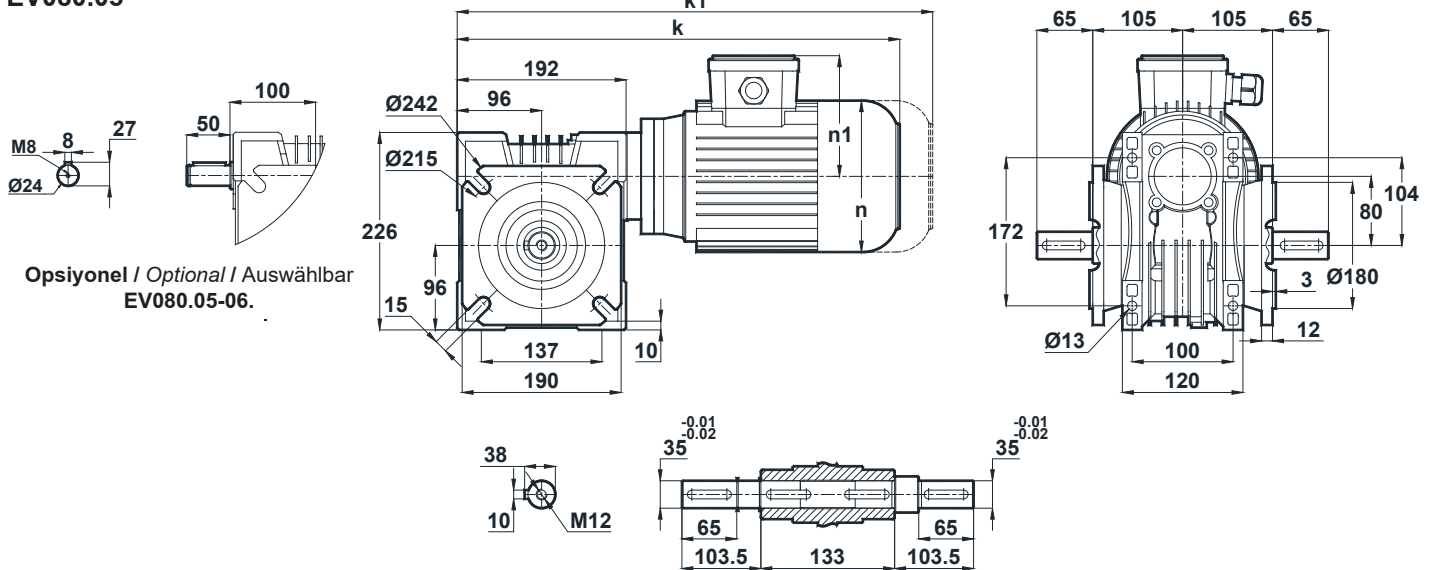

IEC B14	80	90S	90L	100L	112M
k	457,5	477,5	502,5	534,5	554,5
k1	577,5	602,5	627,5	669,5	689,5
n	156	176	176	194	218
n1	118	126	126	135	146

### Klemens Pozisyonları / Terminal Box Positions / Klemmenkasten

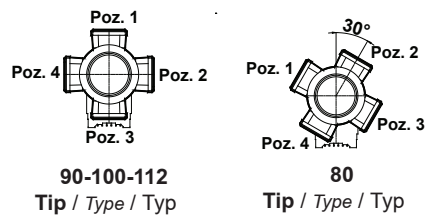

Motorlar B14 flanş ile bağlanmıştır. / Motor connections are with IEC B14 Flange / Motor Befestigung mit IEC B14 Flansch.  
"k1" Ölçüsü frenli redüktörlere aittir. 56,63,71 tip elektrik motorlu redüktörler soğutmasız, diğerleri soğutmalıdır.  
Dimensions "k1" is for motors with brake. Gearboxes with 56,63,71 type electrical motors are not fan cooled, other types are fan cooled.  
Maße "k1" ist für Bremsenmotoren. Getrieben mit 56,63,71 typ Motoren sind ohne Kühlung, andere Typen sind mit Ventilator gekühlt.



# Ölçü Sayfaları Dimension Pages Abmessungsseiten

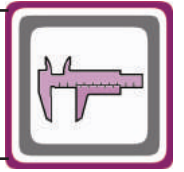

-Mil ucu çekirme deliği DIN 332 sayfa 2 / Tapped center hole to DIN 332, sheet 2 / Zentrierung mit Gewinde DIN 332, Blatt 2

EV080.08

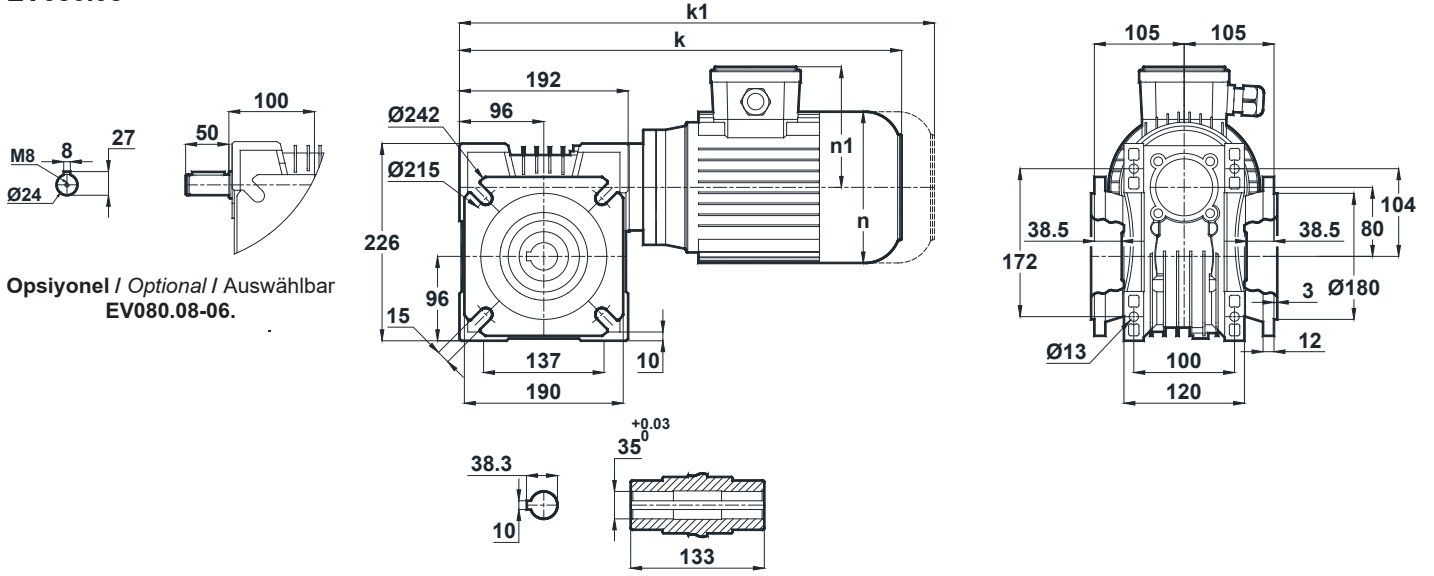

Opsiyonel / Optional / Auswählbar  
EV080.08-06.

IEC B14	80	90S	90L	100L	112M
k	457,5	477,5	502,5	534,5	554,5
k1	577,5	602,5	627,5	669,5	689,5
n	156	176	176	194	218
n1	118	126	126	135	146

Klemens Pozisyonları / Terminal Box Positions / Klemmenkasten

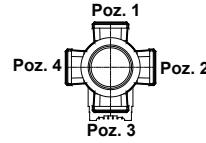

90-100-112  
Tip / Type / Typ

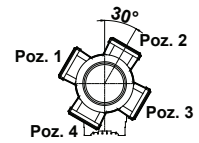

80  
Tip / Type / Typ

Motorlar B14 flans ile bağlanmıştır. / Motor connections are with IEC B14 Flange / Motor Befestigung mit IEC B14 Flansch.

"k1" Ölçüsü frenli redüktörlere aittir. 56,63,71 tip elektrik motorlu redüktörler soğutmasız, diğerleri soğutmalıdır.

Dimensions "k1" is for motors with brake. Gearboxes with 56,63,71 type electrical motors are not fan cooled, other types are fan cooled.

Maße "k1" sind für Bremsenmotoren. Getrieben mit 56,63,71 Motortypen sind ohne Kühlung, andere Typen sind mit Ventilator gekühlt.



# Ölçü Sayfaları Dimension Pages Abmessungsseiten

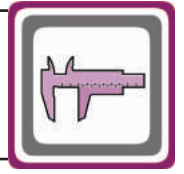

-Mil ucu çekirme deliği DIN 332 sayfa 2 / Tapped center hole to DIN 332, sheet 2 / Zentrierung mit Gewinde DIN 332, Blatt 2

## EV100.00

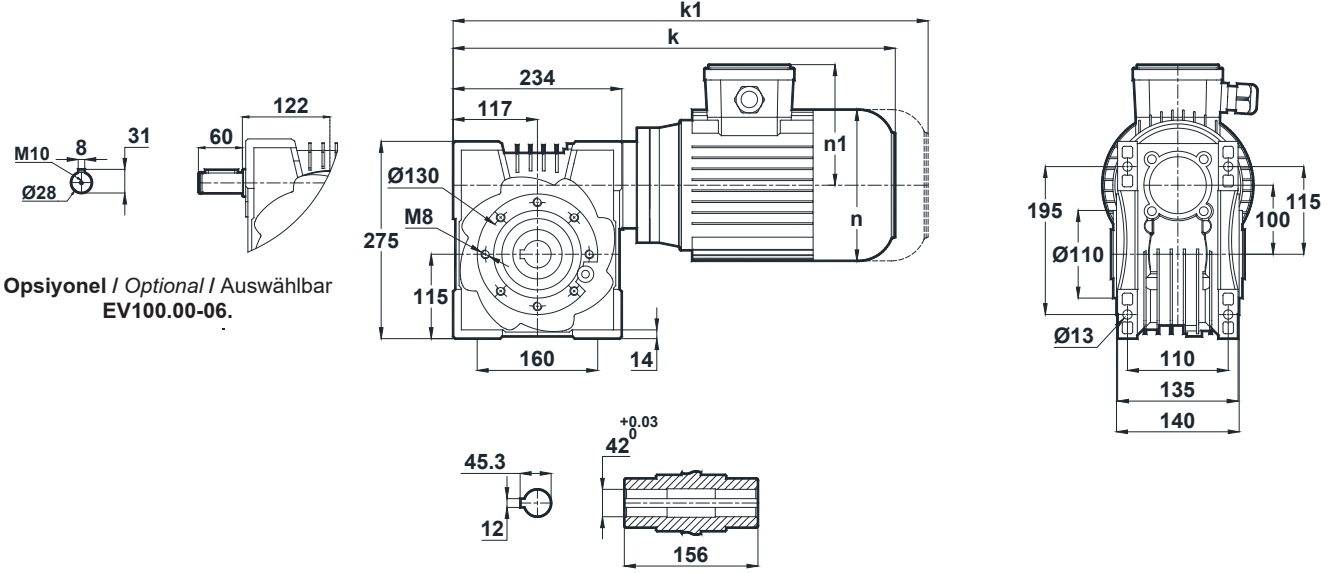

Opsiyonel / Optional / Auswählbar  
EV100.00-06.

## EV100.01

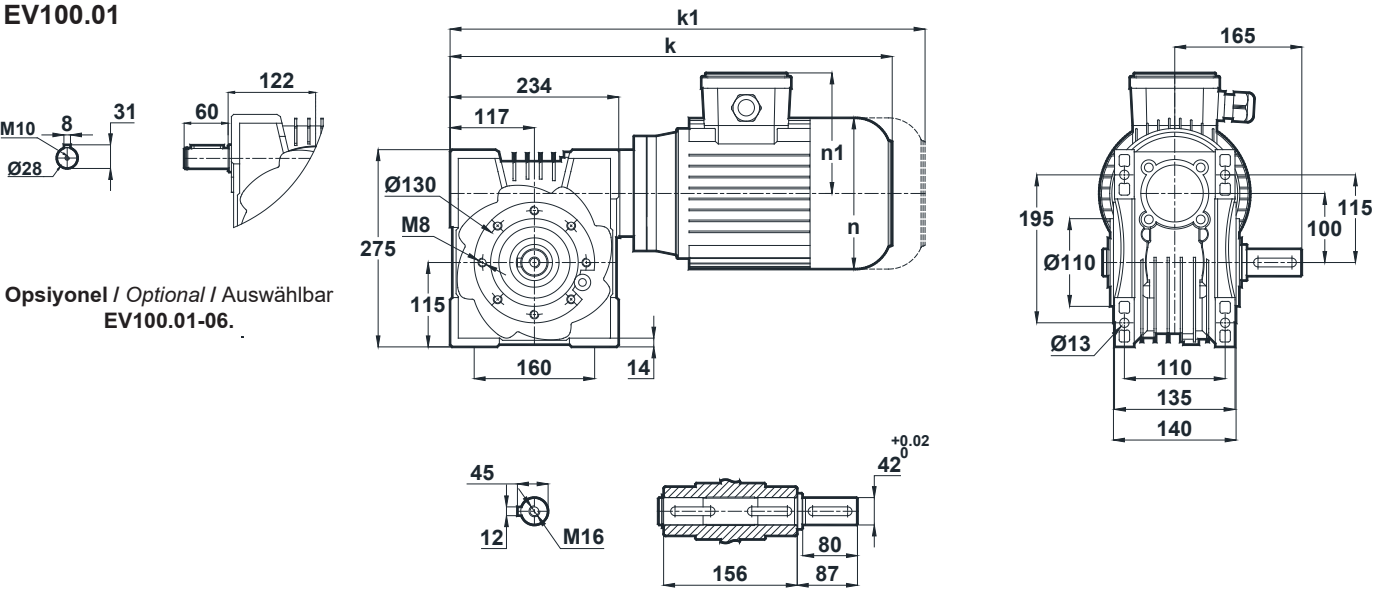

Opsiyonel / Optional / Auswählbar  
EV100.01-06.

IEC B14	80	90S	90L	100L	112M
k	499,5	519,5	544,5	576,5	596,5
k1	619,5	644,5	669,5	711,5	731,5
n	156	176	176	194	218
n1	118	126	126	135	146

Klemens Pozisyonları / Terminal Box Positions / Klemmenkasten

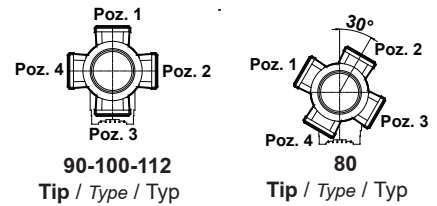

Motorlar B14 flanş ile bağlanmıştır. / Motor connections are with IEC B14 Flange / Motor Befestigung mit IEC B14 Flansch.  
"k1" Ölçüsü frenli redüktörlere aittir. 56,63,71 tip elektrik motorlu redüktörler soğutmasız, diğerleri soğutmalıdır.  
Dimensions "k1" is for motors with brake. Gearboxes with 56,63,71 type electrical motors are not fan cooled, other types are fan cooled.  
Maße "k1" ist für Bremsenmotoren. Getrieben mit 56,63,71 typ Motoren sind ohne Kühlung, andere Typen sind mit Ventilator gekühlt.



# Ölçü Sayfaları Dimension Pages Abmessungsseiten

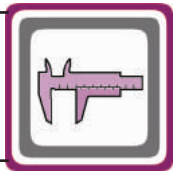

-Mil ucu çekirme deliği DIN 332 sayfa 2 / Tapped center hole to DIN 332, sheet 2 / Zentrierung mit Gewinde DIN 332, Blatt 2

## EV100.02

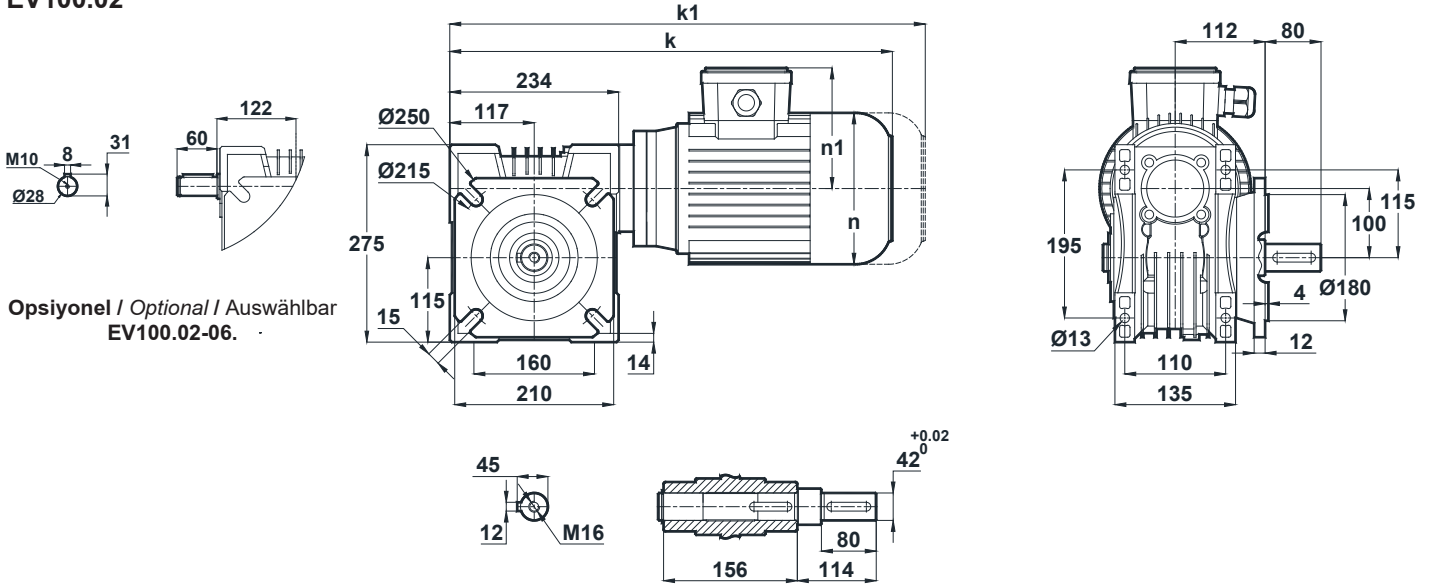

## EV100.03

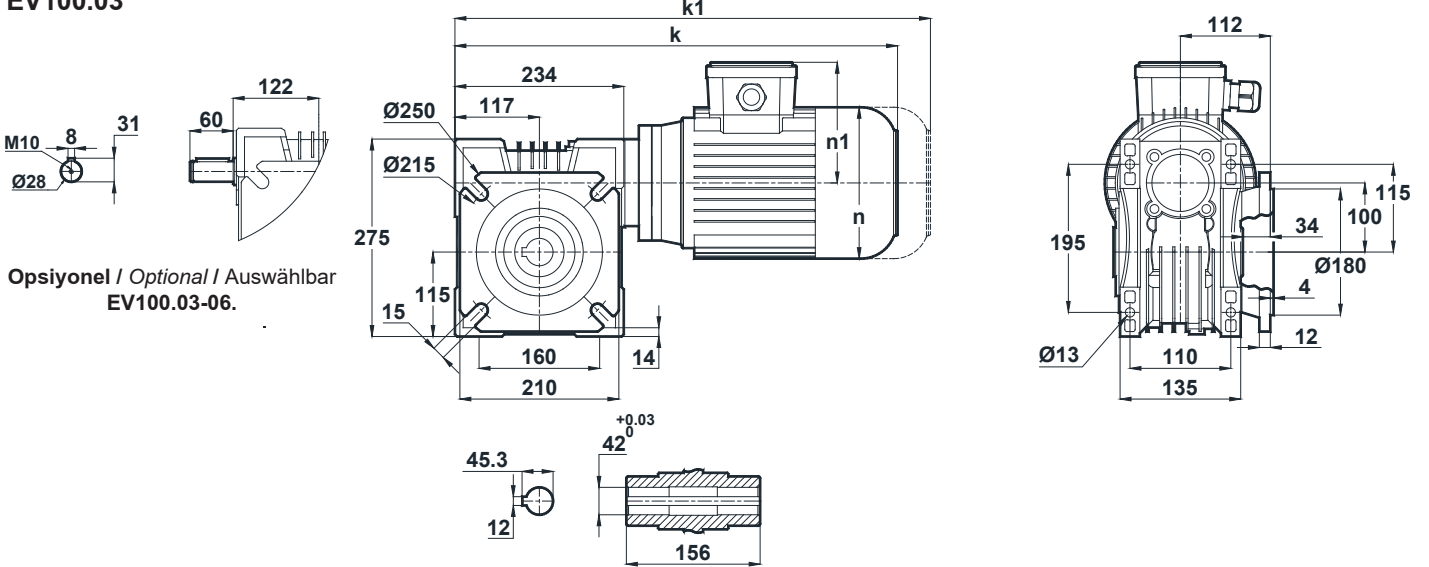

IEC B14	80	90S	90L	100L	112M
k	499,5	519,5	544,5	576,5	596,5
k1	619,5	644,5	669,5	711,5	731,5
n	156	176	176	194	218
n1	118	126	126	135	146

### Klemens Pozisyonları / Terminal Box Positions / Klemmenkasten

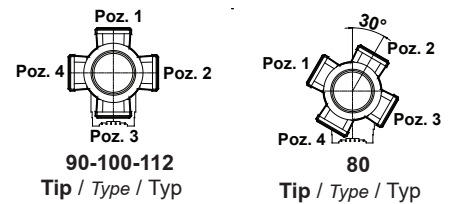

Motorlar B14 flanş ile bağlanmıştır. / Motor connections are with IEC B14 Flange / Motor Befestigung mit IEC B14 Flansch.

"k1" Ölçüsü frenli redüktörlere aittir. 56,63,71 tip elektrik motorlu redüktörler soğutmasız, diğerleri soğutmalıdır.

Dimensions "k1" is for motors with brake. Gearboxes with 56,63,71 type electrical motors are not fan cooled, other types are fan cooled.

Maße "k1" sind für Bremsenmotoren. Getrieben mit 56,63,71 Motortypen sind ohne Kühlung, andere Typen sind mit Ventilator gekühlt.



# Ölçü Sayfaları Dimension Pages Abmessungsseiten

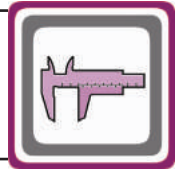

-Mil ucu çektirme deliği DIN 332 sayfa 2 / Tapped center hole to DIN 332, sheet 2 / Zentrierung mit Gewinde DIN 332, Blatt 2

## EV100.04

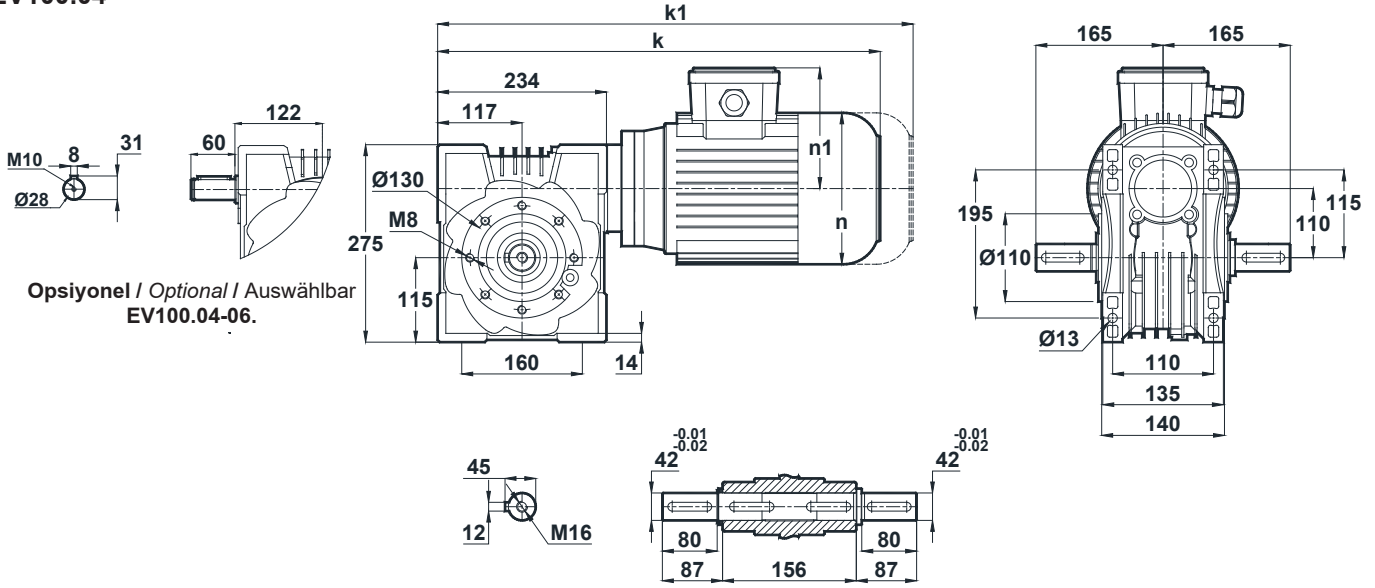

## EV100.05

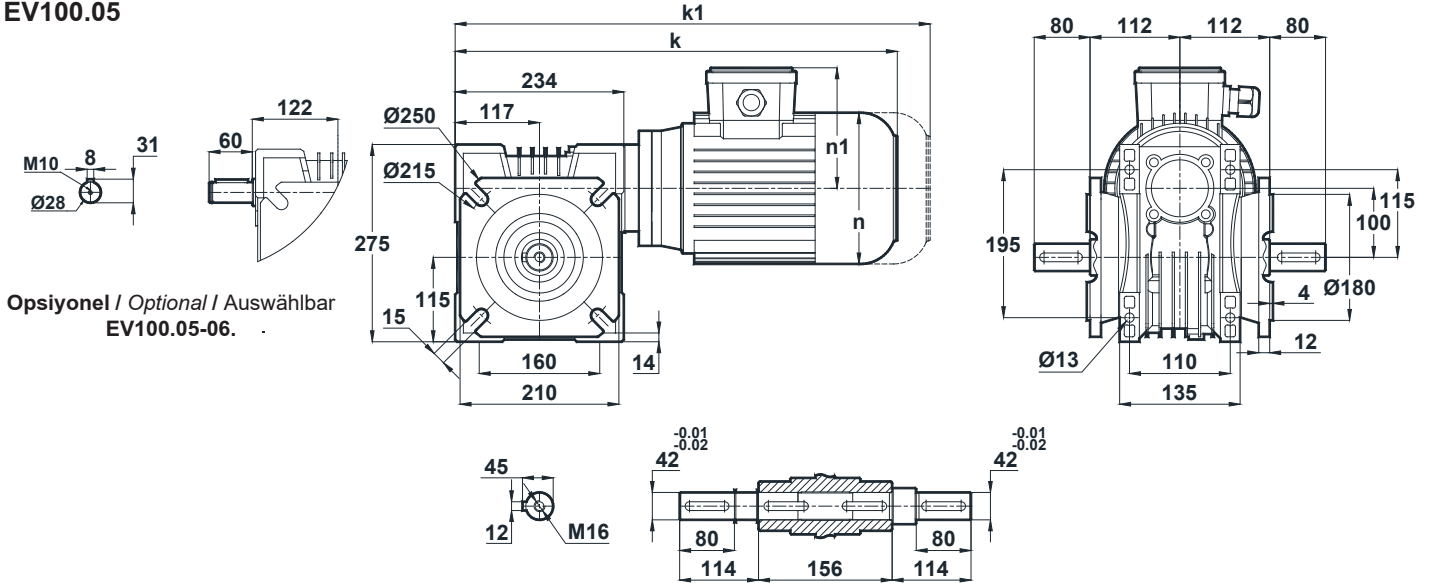

IEC B14	80	90S	90L	100L	112M
k	499,5	519,5	544,5	576,5	596,5
k1	619,5	644,5	669,5	711,5	731,5
n	156	176	176	194	218
n1	118	126	126	135	146

### Klemens Pozisyonları / Terminal Box Positions / Klemmenkasten

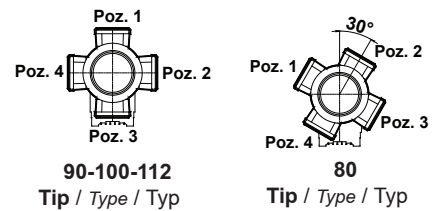

Motorlar B14 flanş ile bağlanmıştır. / Motor connections are with IEC B14 Flange / Motor Befestigung mit IEC B14 Flansch.  
"k1" Ölçüsü frenli redüktörlere aittir. 56,63,71 tip elektrik motorlu redüktörler soğutmasız, diğerleri soğutmalıdır.  
Dimensions "k1" is for motors with brake. Gearboxes with 56,63,71 type electrical motors are not fan cooled, other types are fan cooled.  
Maße "k1" ist für Bremsenmotoren. Getrieben mit 56,63,71 typ Motoren sind ohne Kühlung, andere Typen sind mit Ventilator gekühlt.



# Ölçü Sayfaları Dimension Pages Abmessungsseiten

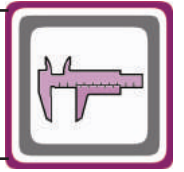

-Mil ucu çekirme deliği DIN 332 sayfa 2 / Tapped center hole to DIN 332, sheet 2 / Zentrierung mit Gewinde DIN 332, Blatt 2

EV100.08

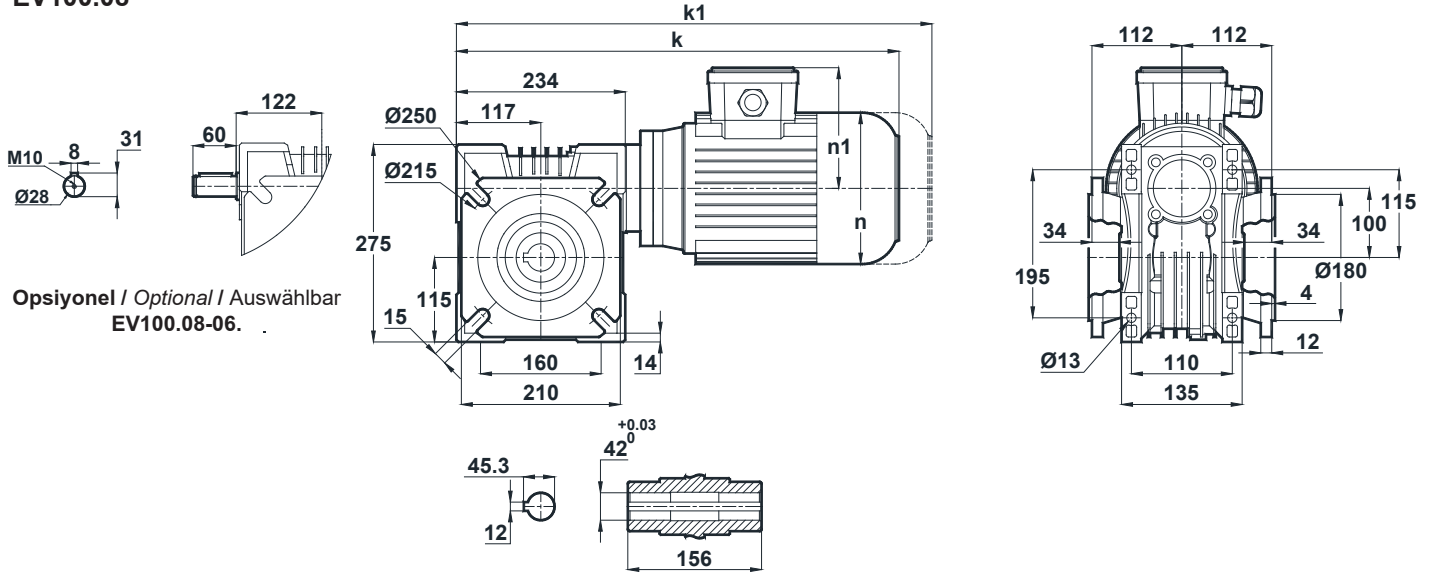

Opsiyonel / Optional / Auswählbar  
EV100.08-06.

IEC B14	80	90S	90L	100L	112M
k	499,5	519,5	544,5	576,5	596,5
k1	619,5	644,5	669,5	711,5	731,5
n	156	176	176	194	218
n1	118	126	126	135	146

Klemens Pozisyonları / Terminal Box Positions / Klemmenkasten

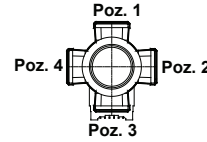

90-100-112  
Tip / Type / Typ

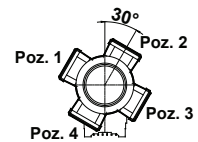

80  
Tip / Type / Typ

Motorlar B14 flanş ile bağlanmıştır. / Motor connections are with IEC B14 Flange / Motor Befestigung mit IEC B14 Flansch.

"k1" Ölçüsü frenli redüktörlere aittir. 56,63,71 tip elektrik motorlu redüktörler soğutmasız, diğerleri soğutmalıdır.

Dimensions "k1" is for motors with brake. Gearboxes with 56,63,71 type electrical motors are not fan cooled, other types are fan cooled.

Maße "k1" sind für Bremsenmotoren. Getrieben mit 56,63,71 Motortypen sind ohne Kühlung, andere Typen sind mit Ventilator gekühlt.



# Ölçü Sayfaları Dimension Pages Abmessungsseiten

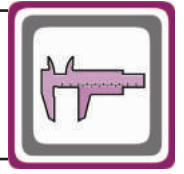

-Mil ucu çektirme deliği DIN 332 sayfa 2 / Tapped center hole to DIN 332, sheet 2 / Zentrierung mit Gewinde DIN 332, Blatt 2

## EV125.00

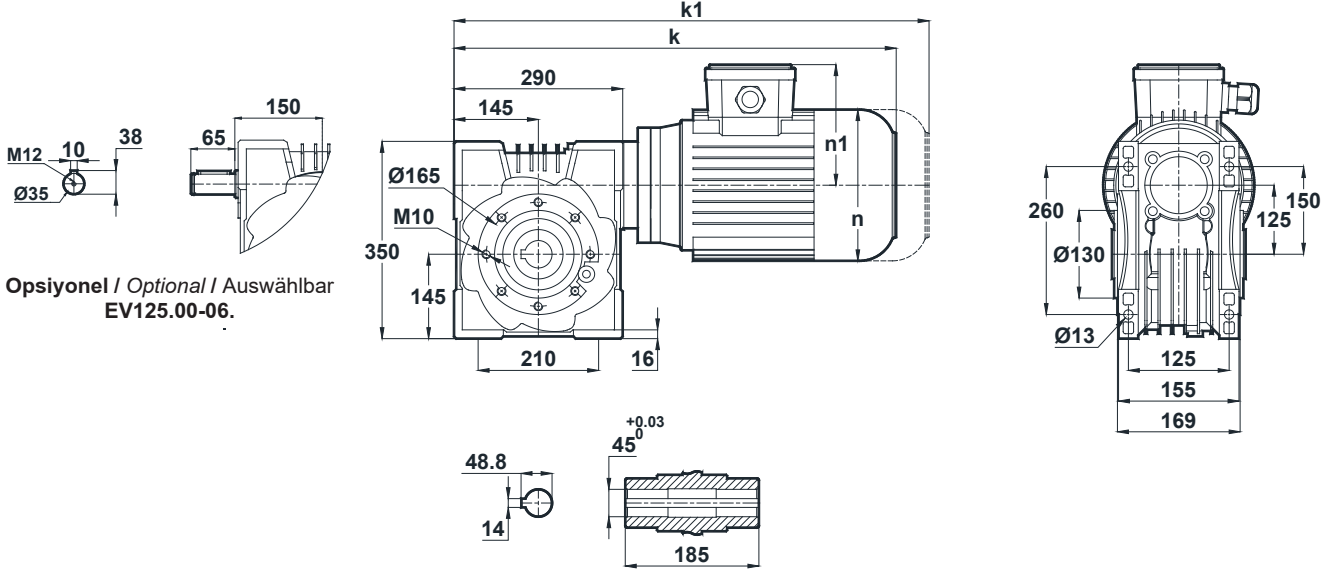

Opsiyonel / Optional / Auswählbar  
EV125.00-06.

## EV125.01

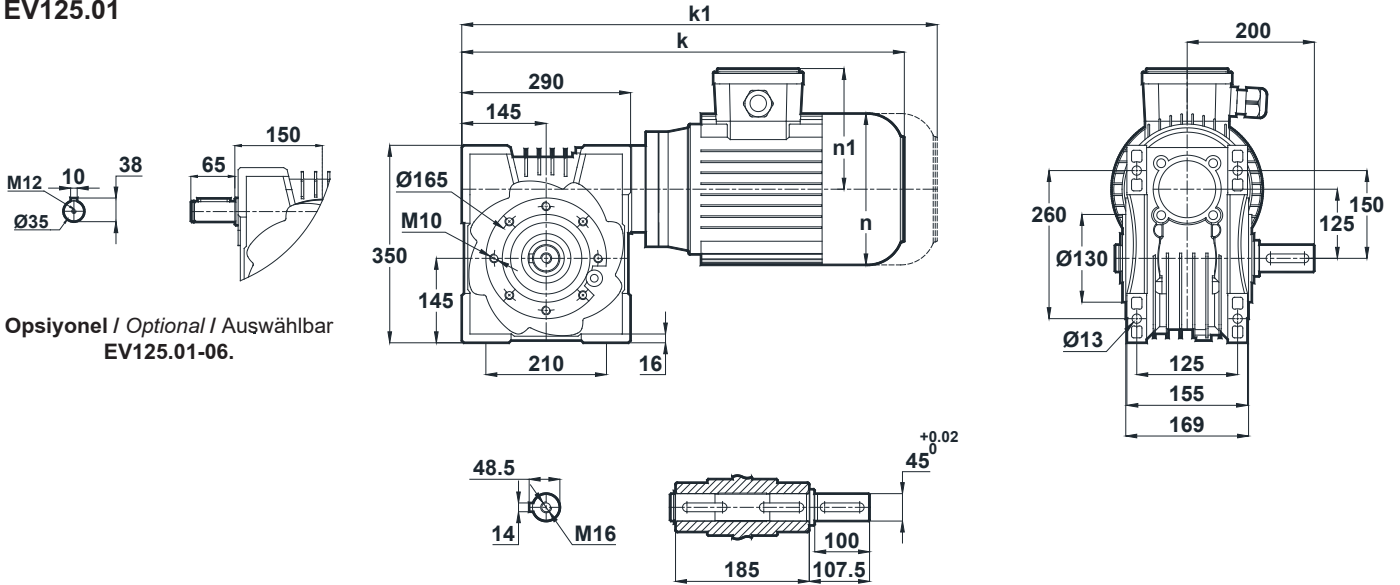

Opsiyonel / Optional / Auswählbar  
EV125.01-06.

IEC B14	90S	90L	100L	112M	132S	132M
k	582	607	639	659	698	736
k1	707	732	774	794	843	881
n	176	176	194	218	257	257
n1	126	126	135	146	168	168

Klemens Pozisyonları / Terminal Box Positions / Klemmenkasten

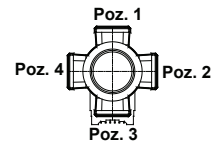

90-100-112-132  
Tip / Type / Typ

Motorlar B14 flanş ile bağlanmıştır. / Motor connections are with IEC B14 Flange / Motor Befestigung mit IEC B14 Flansch.  
"k1" Ölçüsü frenli redüktörlere aittir. 56,63,71 tip elektrik motorlu redüktörler soğutmasız, diğerleri soğutmalıdır.  
Dimensions "k1" is for motors with brake. Gearboxes with 56,63,71 type electrical motors are not fan cooled, other types are fan cooled.  
Maße "k1" ist für Bremsenmotoren. Getrieben mit 56,63,71 typ Motoren sind ohne Kühlung, andere Typen sind mit Ventilator gekühlt.





# Ölçü Sayfaları Dimension Pages Abmessungsseiten

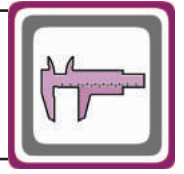

-Mil ucu çekirme deliği DIN 332 sayfa 2 / Tapped center hole to DIN 332, sheet 2 / Zentrierung mit Gewinde DIN 332, Blatt 2

## EV125.04

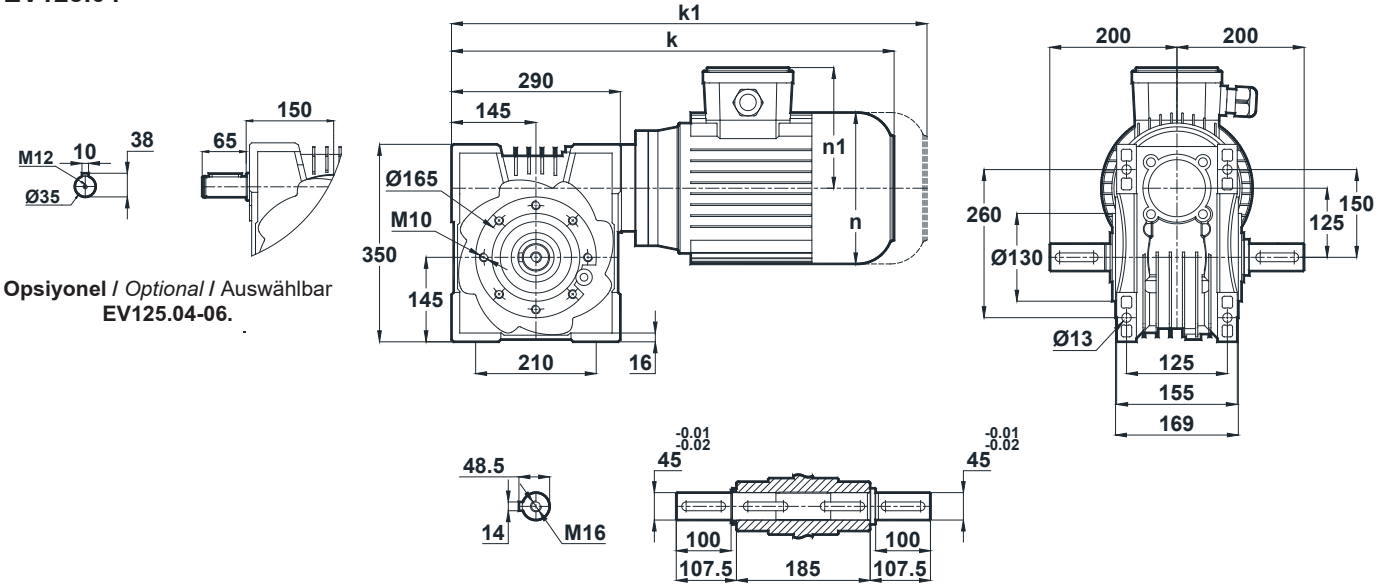

## EV125.05

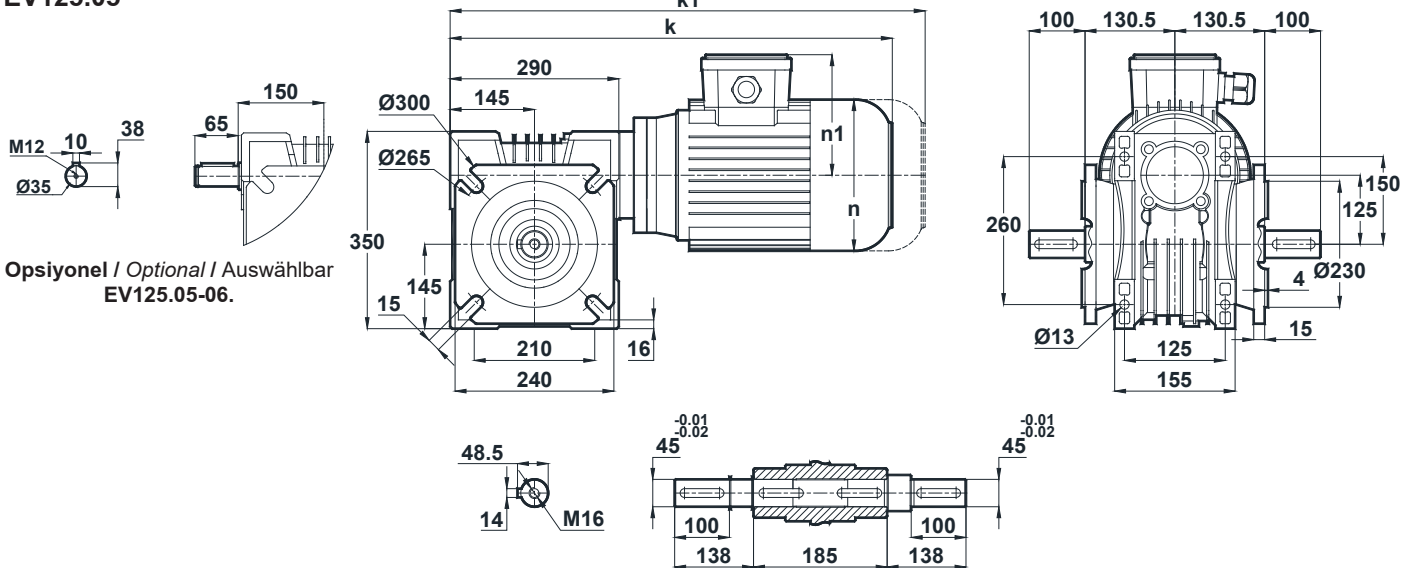

IEC B14	90S	90L	100L	112M	132S	132M
k	582	607	639	659	698	736
k1	707	732	774	794	843	881
n	176	176	194	218	257	257
n1	126	126	135	146	168	168

Klemens Pozisyonları / Terminal Box Positions / Klemmenkasten

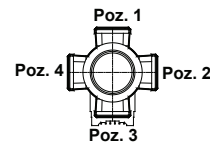

90-100-112-132  
Tip / Type / Typ

Motorlar B14 flanş ile bağlanmıştır. / Motor connections are with IEC B14 Flange / Motor Befestigung mit IEC B14 Flansch.  
"k1" Ölçüsü frenli redüktörlere aittir. 56,63,71 tip elektrik motorlu redüktörler soğutmasız, diğerleri soğutmalıdır.  
Dimensions "k1" is for motors with brake. Gearboxes with 56,63,71 type electrical motors are not fan cooled, other types are fan cooled.  
Maße "k1" ist für Bremsenmotoren. Getrieben mit 56,63,71 typ Motoren sind ohne Kühlung, andere Typen zind mit Ventilator gekühlt.



# Ölçü Sayfaları Dimension Pages Abmessungsseiten

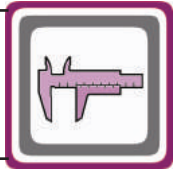

-Mil ucu çekirme deliği DIN 332 sayfa 2 / Tapped center hole to DIN 332, sheet 2 / Zentrierung mit Gewinde DIN 332, Blatt 2

## EV125.08

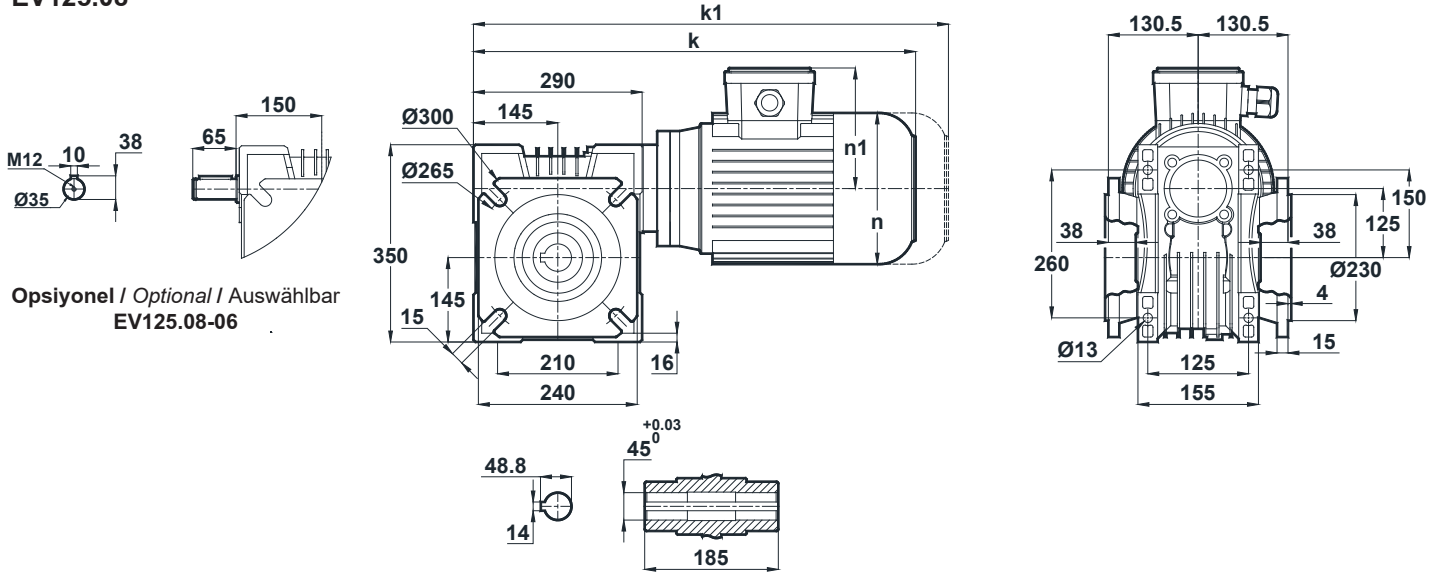

IEC B14	90S	90L	100L	112M	132S	132M
k	582	607	639	659	698	736
k1	707	732	774	794	843	881
n	176	176	194	218	257	257
n1	126	126	135	146	168	168

Klemens Pozisyonları / Terminal Box Positions / Klemmenkasten

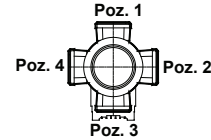

90-100-112  
Tip / Type / Typ

Motorlar B14 flanş ile bağlanmıştır. / Motor connections are with IEC B14 Flange / Motor Befestigung mit IEC B14 Flansch.

"k1" Ölçüsü frenli redüktörlere aittir. 56,63,71 tip elektrik motorlu redüktörler soğutmasız, diğerleri soğutmalıdır.

Dimensions "k1" is for motors with brake. Gearboxes with 56,63,71 type electrical motors are not fan cooled, other types are fan cooled.

Maße "k1" sind für Bremsmotoren. Getrieben mit 56,63,71 Motortypen sind ohne Kühlung, andere Typen sind mit Ventilator gekühlt.



# Ölçü Sayfaları Dimension Pages Abmessungsseiten

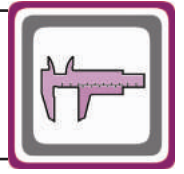

-Mil ucu çekirme deliği DIN 332 sayfa 2 / Tapped center hole to DIN 332, sheet 2 / Zentrierung mit Gewinde DIN 332, Blatt 2

EV040.□ - 030

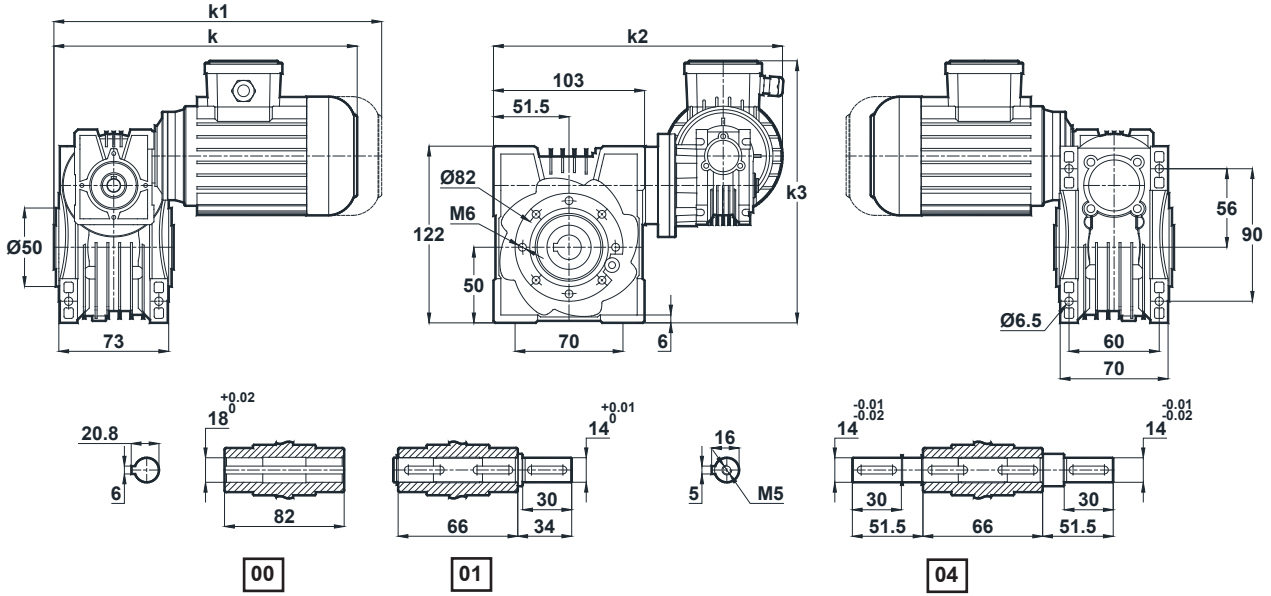

IEC B14	k	k1	k2	k3
56	247	-	235,5	216
63	299	352	243,5	217

EV040.□ - 030

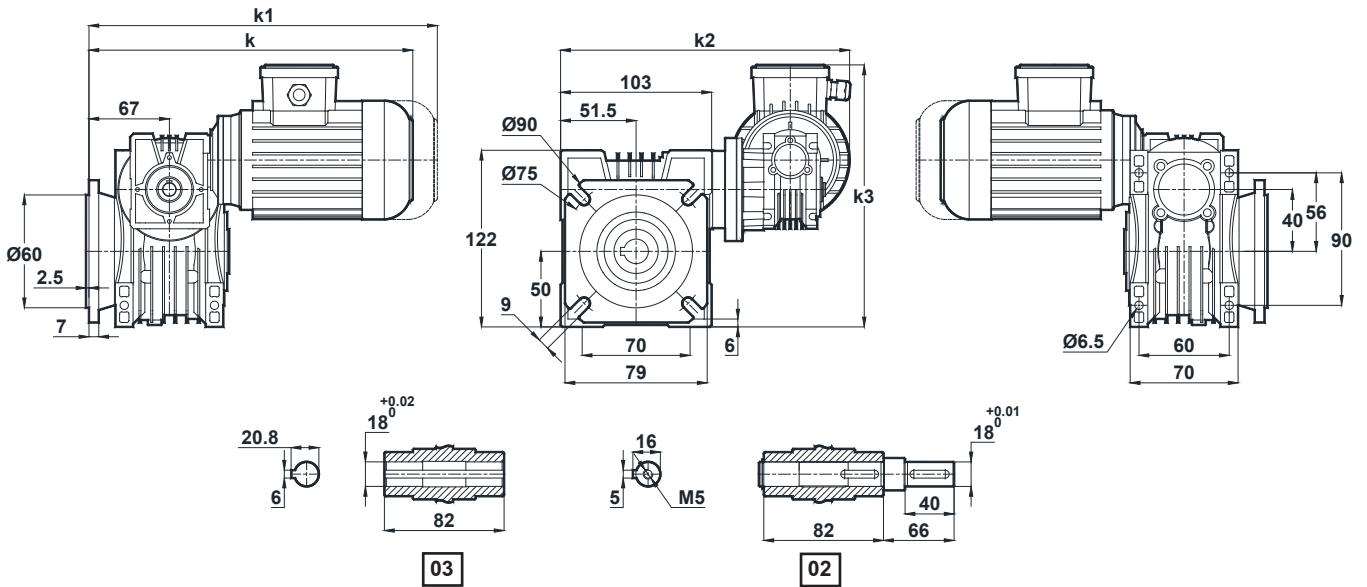

IEC B14	k	k1	k2	k3
56	261,5	-	235,5	216
63	313,5	366,5	243,5	217

Motorlar B14 flanş ile bağlanmıştır. / Motor connections are with IEC B14 Flange / Motor Befestigung mit IEC B14 Flansch.  
"k1" Ölçüsü frenli redüktörlere aittir. 56,63,71 tip elektrik motorlu redüktörler soğutmasız, diğerleri soğutmalıdır.  
Dimensions "k1" is for motors with brake. Gearboxes with 56,63,71 type electrical motors are not fan cooled, other types are fan cooled.  
Maße "k1" ist für Bremsmotoren. Getrieben mit 56,63,71 typ Motoren sind ohne Kühlung, andere Typen zind mit Ventilator gekühlt.



# Ölçü Sayfaları Dimension Pages Abmessungsseiten

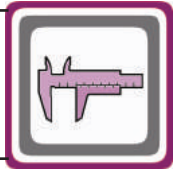

-Mil ucu çekirme deliği DIN 332 sayfa 2 / Tapped center hole to DIN 332, sheet 2 / Zentrierung mit Gewinde DIN 332, Blatt 2

EV050.□ - 030

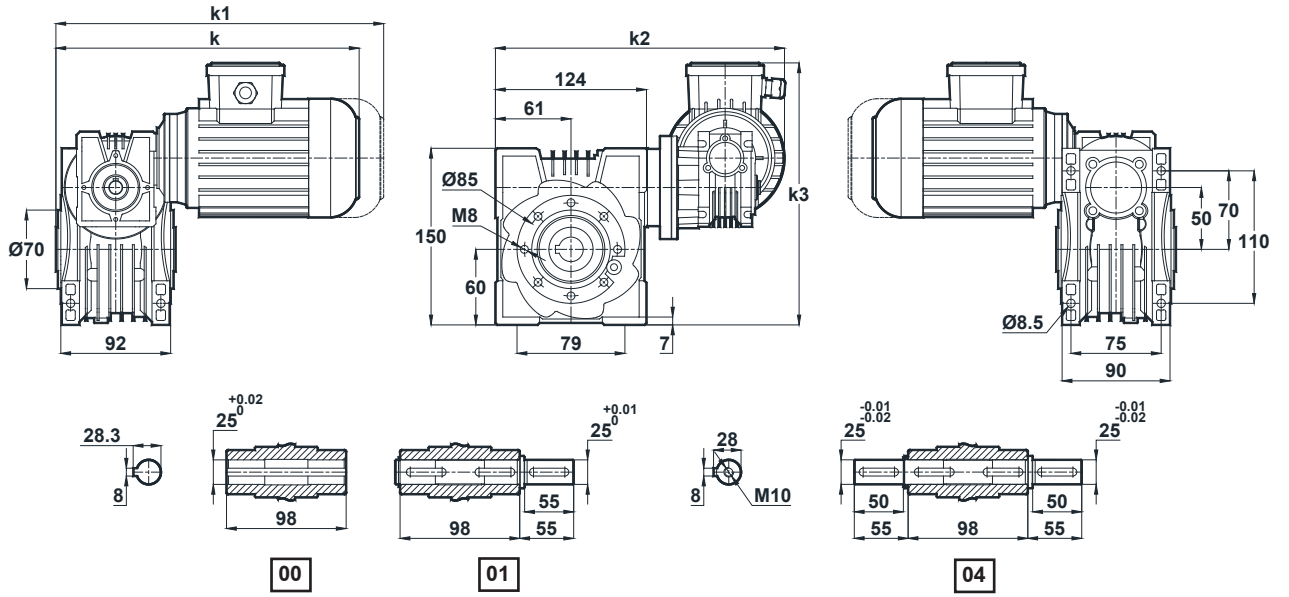

IEC B14	k	k1	k2	k3
56	247	-	256,5	236
63	299	352	264,5	237

EV050.□ - 030

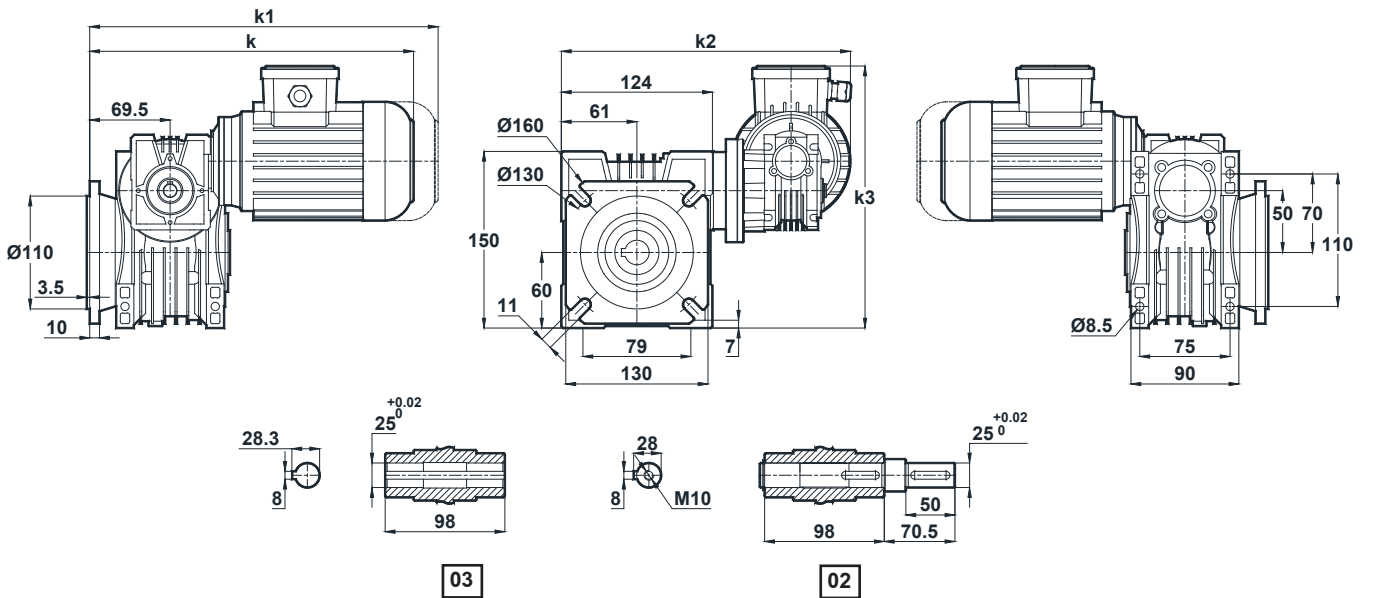

IEC B14	k	k1	k2	k3
56	265,5	-	256,5	236
63	317,5	370,5	264,5	237

Motorlar B14 flanş ile bağlanmıştır. / Motor connections are with IEC B14 Flange / Motor Befestigung mit IEC B14 Flansch.  
"k1" Ölçüsü frenli redüktörlere aittir. 56,63,71 tip elektrik motorlu redüktörler soğutmasız, diğerleri soğutmalıdır.  
Dimensions "k1" is for motors with brake. Gearboxes with 56,63,71 type electrical motors are not fan cooled, other types are fan cooled.  
Maße "k1" ist für Bremsenmotoren. Getrieben mit 56,63,71 typ Motoren sind ohne Kühlung, andere Typen sind mit Ventilator gekühlt.



# Ölçü Sayfaları Dimension Pages Abmessungsseiten

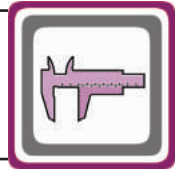

-Mil ucu çekirme deliği DIN 332 sayfa 2 / Tapped center hole to DIN 332, sheet 2 / Zentrierung mit Gewinde DIN 332, Blatt 2

EV063.□ - 030

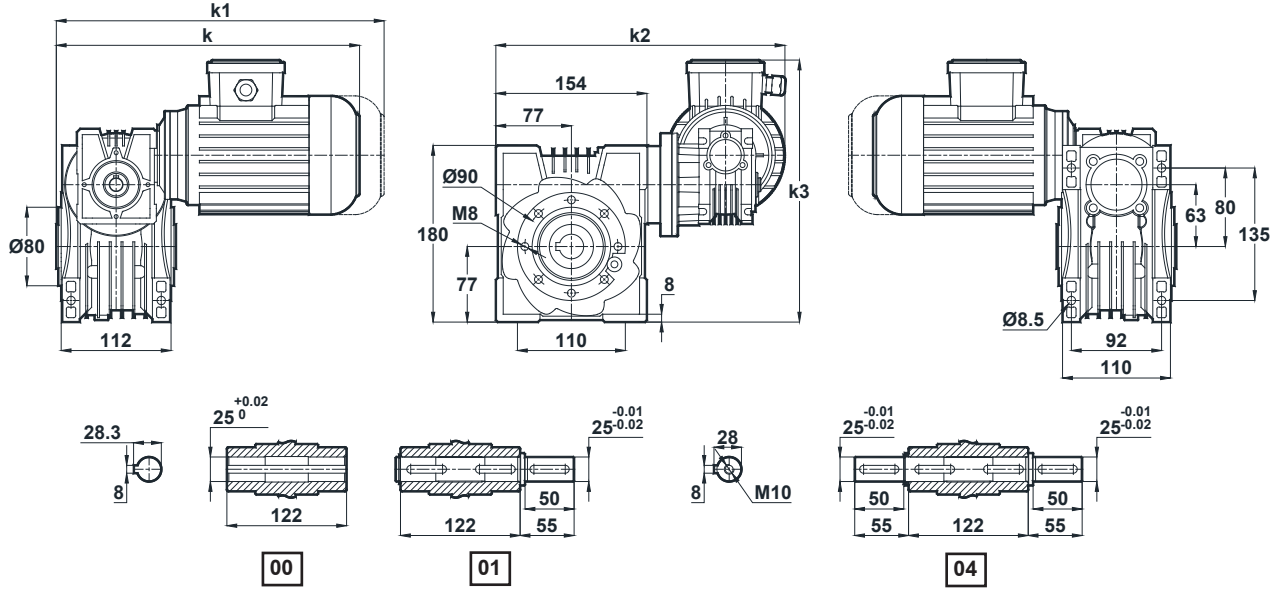

IEC B14	k	k1	k2	k3
56	255,5	-	286,5	266
63	307,5	360,5	294,5	267

EV063.□ - 030

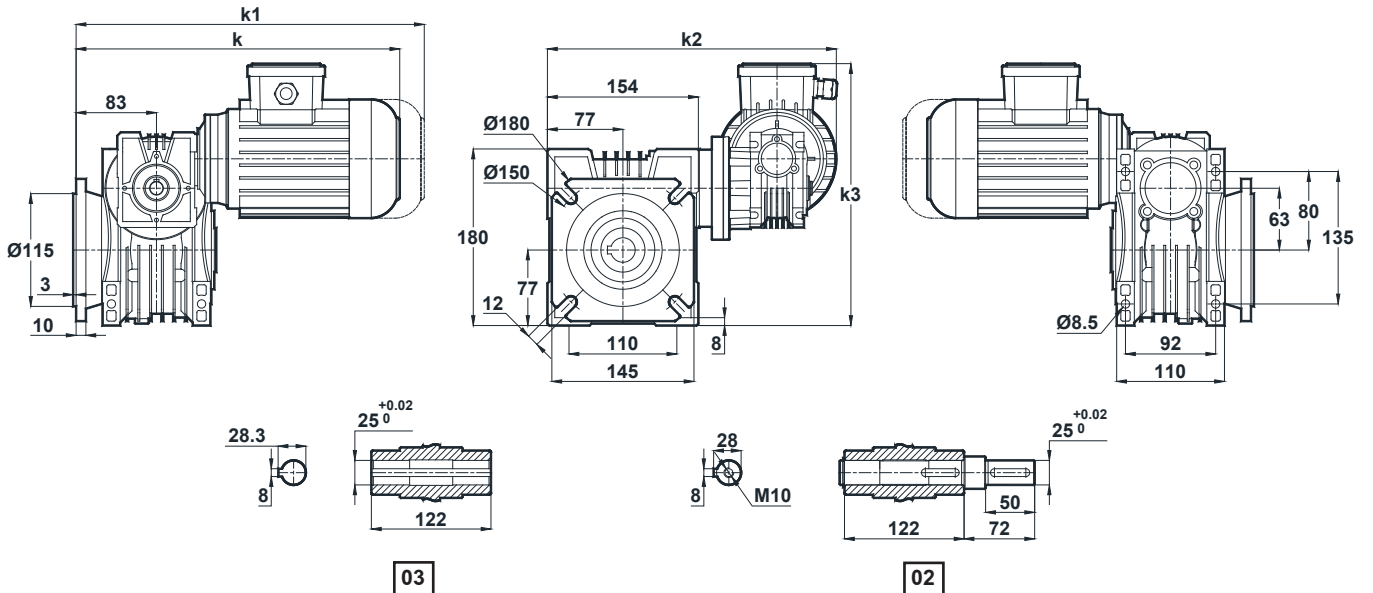

IEC B14	k	k1	k2	k3
56	277,5	-	286,5	266
63	329,5	382,5	294,5	267

Motorlar B14 flanş ile bağlanmıştır. / Motor connections are with IEC B14 Flange / Motor Befestigung mit IEC B14 Flansch.  
"k1" Ölçüsü frenli redüktörlere aittir. 56,63,71 tip elektrik motorlu redüktörler soğutmasız, diğerleri soğutmalıdır.  
Dimensions "k1" is for motors with brake. Gearboxes with 56,63,71 type electrical motors are not fan cooled, other types are fan cooled.  
Maße "k1" ist für Bremsmotoren. Getrieben mit 56,63,71 typ Motoren sind ohne Kühlung, andere Typen zind mit Ventilator gekühlt.



# Ölçü Sayfaları Dimension Pages Abmessungsseiten

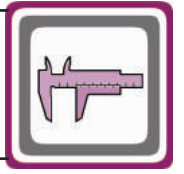

-Mil ucu çekirme deliği DIN 332 sayfa 2 / Tapped center hole to DIN 332, sheet 2 / Zentrierung mit Gewinde DIN 332, Blatt 2

EV075.□ - 040

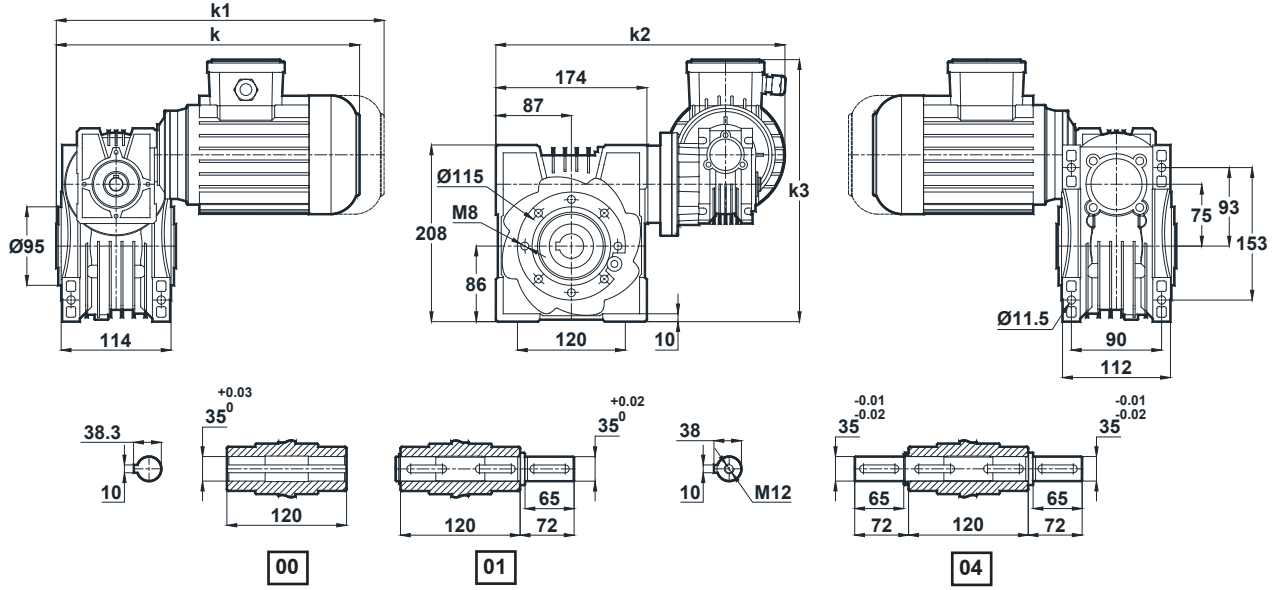

IEC B14	k	k1	k2	k3
63	339,5	392,5	333,5	298
71	365,5	485,5	342	311

EV075.□ - 040

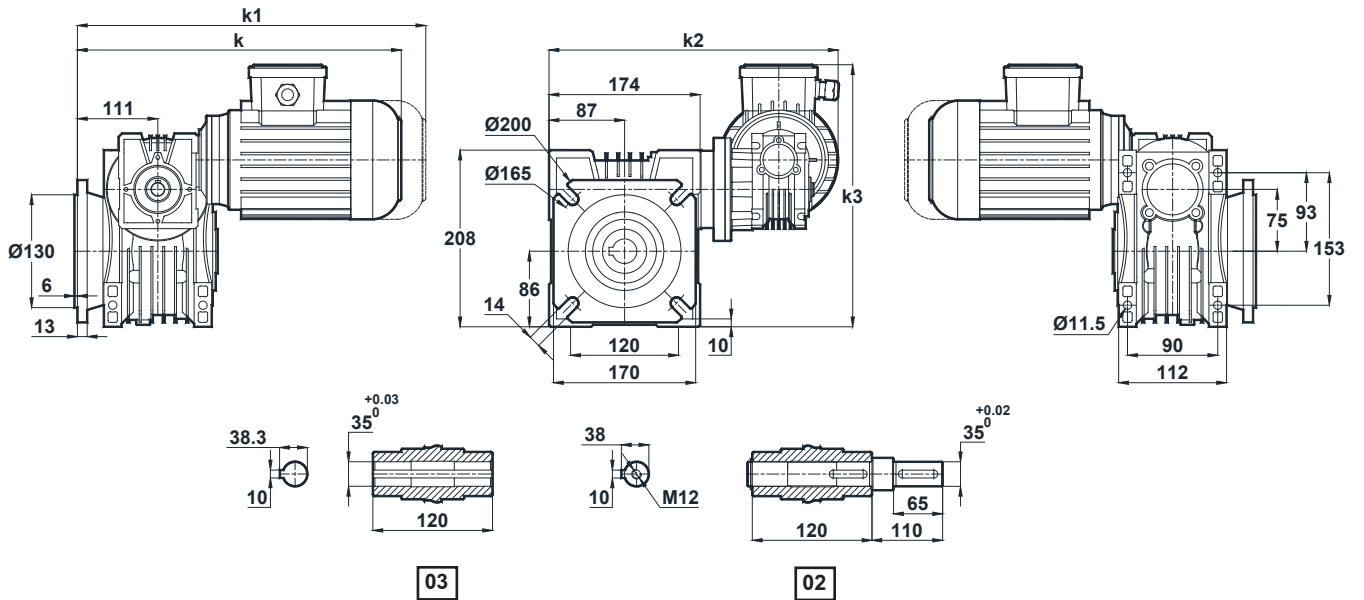

IEC B14	k	k1	k2	k3
63	380,5	433,5	333,5	298
71	406,5	526,5	342	311

Motorlar B14 flanş ile bağlanmıştır. / Motor connections are with IEC B14 Flange / Motor Befestigung mit IEC B14 Flansch.  
"k1" Ölçüsü frenli redüktörlere aittir. 56,63,71 tip elektrik motorlu redüktörler soğutmasız, diğerleri soğutmalıdır.  
Dimensions "k1" is for motors with brake. Gearboxes with 56,63,71 type electrical motors are not fan cooled, other types are fan cooled.  
Maße "k1" ist für Bremsenmotoren. Getrieben mit 56,63,71 typ Motoren sind ohne Kühlung, andere Typen sind mit Ventilator gekühlt.



# Ölçü Sayfaları Dimension Pages Abmessungenseiten

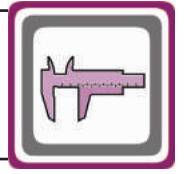

-Mil ucu çekirme deliği DIN 332 sayfa 2 / Tapped center hole to DIN 332, sheet 2 / Zentrierung mit Gewinde DIN 332, Blatt 2

EV080.□ - 040

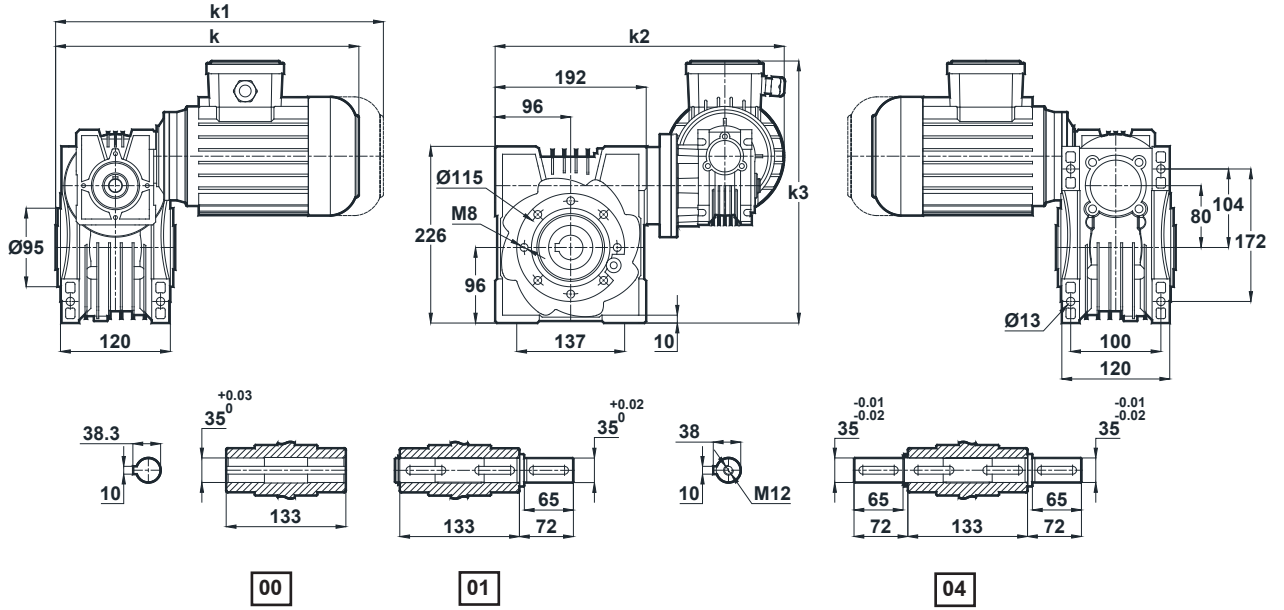

IEC B14	k	k1	k2	k3
63	339,5	392,5	333,5	298
71	365,5	485,5	360	326

EV080.□ - 040

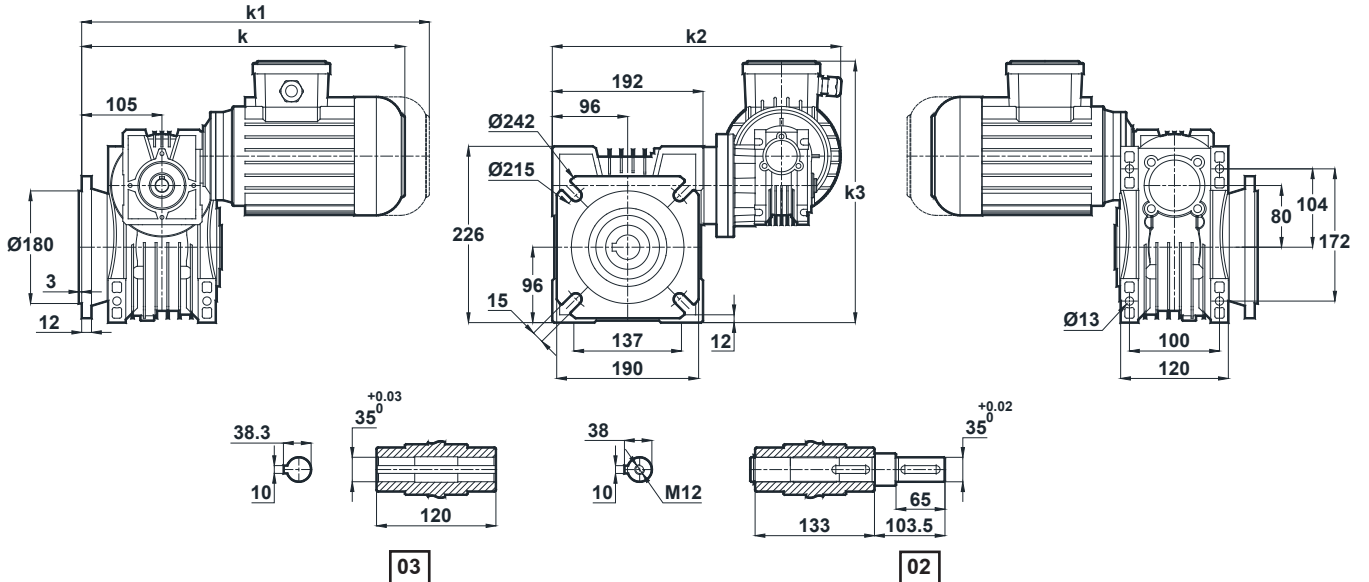

IEC B14	k	k1	k2	k3
63	374,5	427,5	351,5	313
71	400,5	520,5	360	326

Motorlar B14 flanş ile bağlanmıştır. / Motor connections are with IEC B14 Flange / Motor Befestigung mit IEC B14 Flansch.  
"k1" Ölçüsü frenli redüktörlere aittir. 56,63,71 tip elektrik motorlu redüktörler soğutmasız, diğerleri soğutmalıdır.  
Dimensions "k1" is for motors with brake. Gearboxes with 56,63,71 type electrical motors are not fan cooled, other types are fan cooled.  
Maße "k1" ist für Bremsenmotoren. Getrieben mit 56,63,71 typ Motoren sind ohne Kühlung, andere Typen sind mit Ventilator gekühlt.



# Ölçü Sayfaları Dimension Pages Abmessungsseiten



-Mil ucu çektirme deliği DIN 332 sayfa 2 / Tapped center hole to DIN 332, sheet 2 / Zentrierung mit Gewinde DIN 332, Blatt 2

EV100.□ - 050

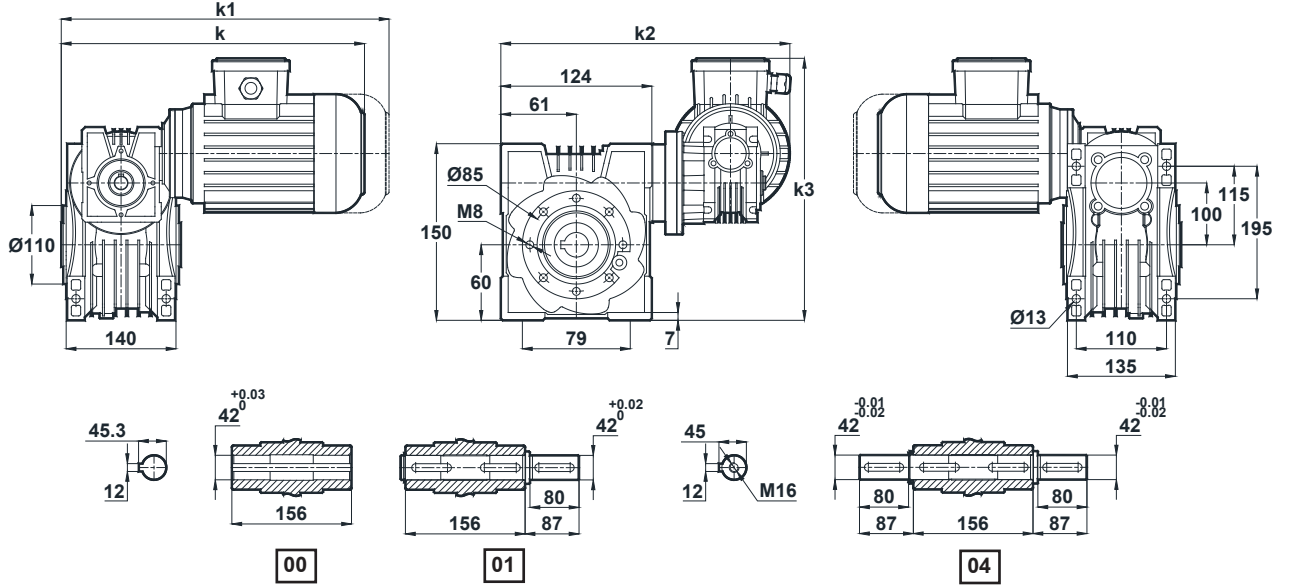

IEC B14	k	k1	k2	k3
63	361	414	390,5	362
71	387	507	399	375
80	407	527	408	383
90S	427	552	418	391
90L	452	577	418	391

EV100.□ - 050

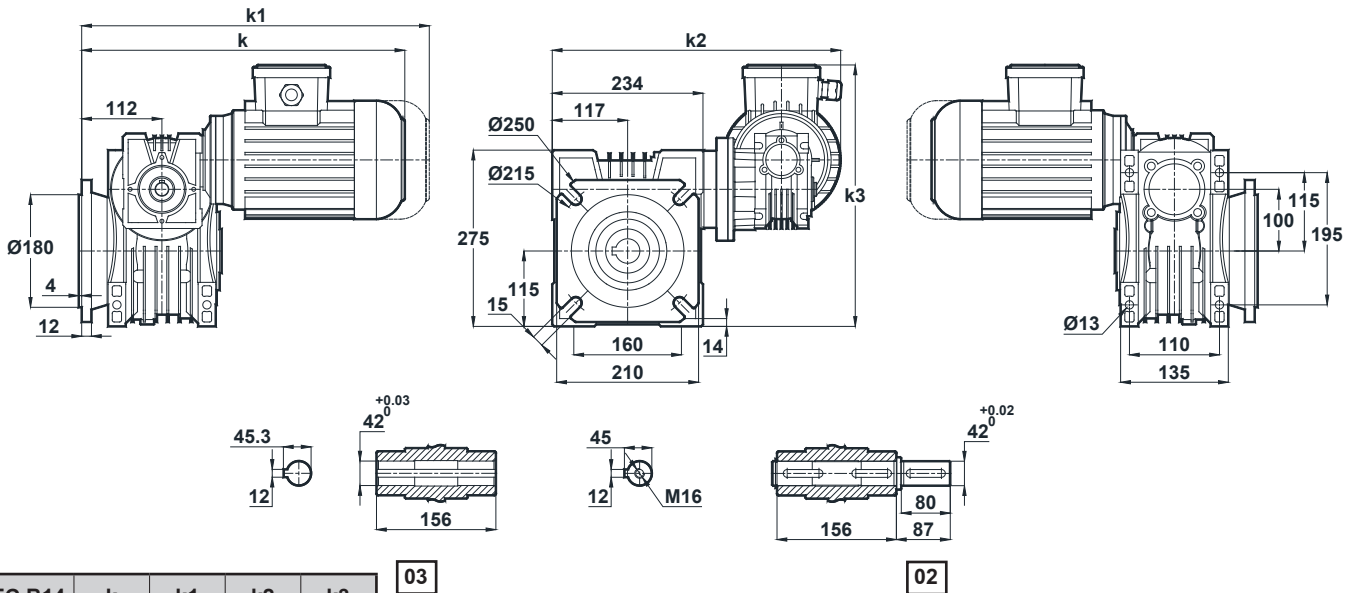

IEC B14	k	k1	k2	k3
63	393	446	390,5	362
71	419	539	399	375
80	439	559	408	383
90S	459	584	418	391
90L	484	609	418	391

Motorlar B14 flanş ile bağlanmıştır. / Motor connections are with IEC B14 Flange / Motor Befestigung mit IEC B14 Flansch.

"k1" Ölçüsü frenli redüktörlere aittir. 56,63,71 tip elektrik motorlu redüktörler soğutmasız, diğerleri soğutmalıdır.

Dimensions "k1" is for motors with brake. Gearboxes with 56,63,71 type electrical motors are not fan cooled, other types are fan cooled.

Maße "k1" ist für Bremsenmotoren. Getrieben mit 56,63,71 typ Motoren sind ohne Kühlung, andere Typen sind mit Ventilator gekühlt.



# Ölçü Sayfaları Dimension Pages Abmessungsseiten

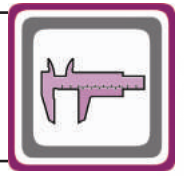

-Mil ucu çektirme deliği DIN 332 sayfa 2 / Tapped center hole to DIN 332, sheet 2 / Zentrierung mit Gewinde DIN 332, Blatt 2

EV125.□ - 063

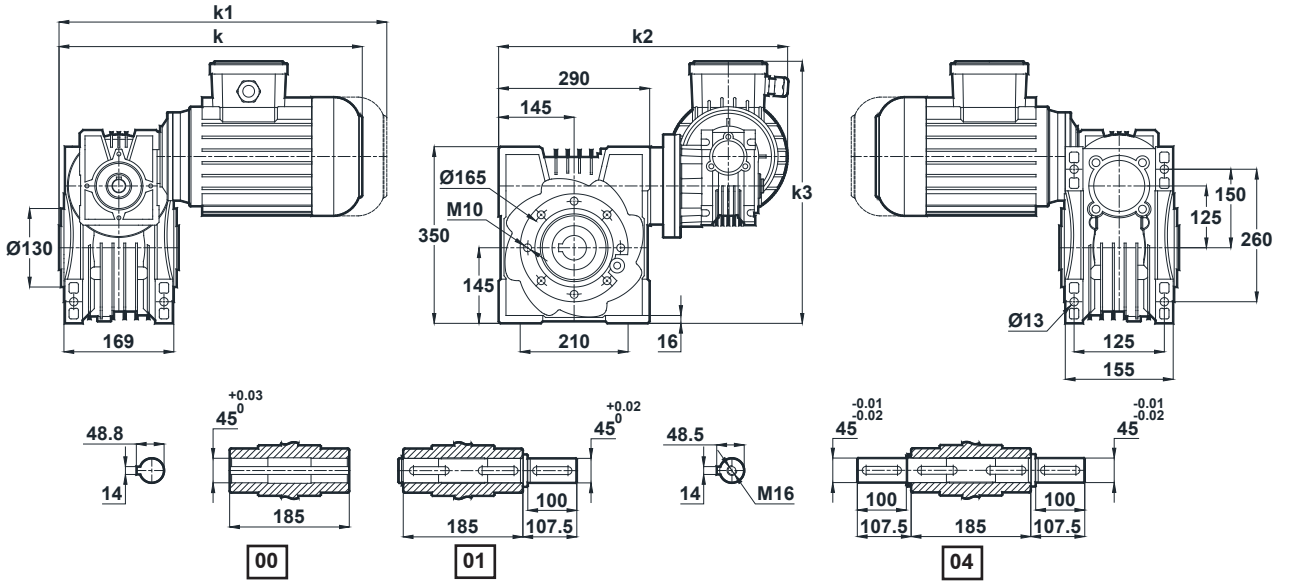

IEC B14	k	k1	k2	k3
71	413,5	533,5	486	443
80	433,5	553,5	495	451
90S	453,5	578,5	505	459
90L	478,5	603,5	505	459

EV125.□ - 063

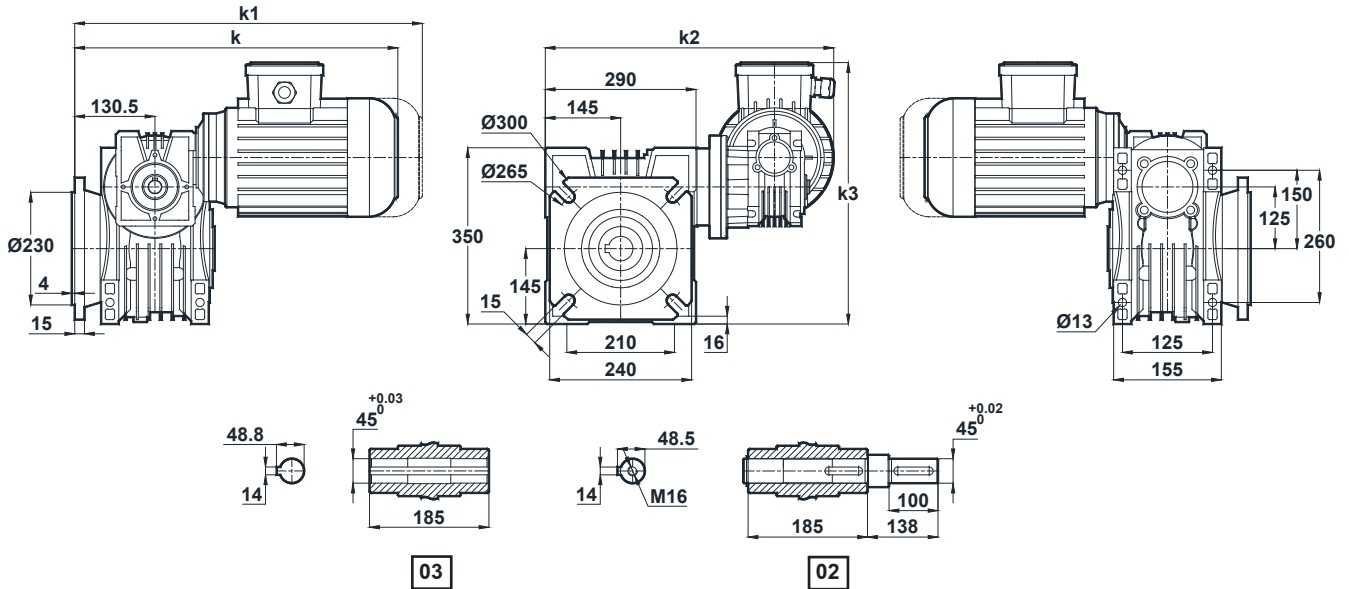

IEC B14	k	k1	k2	k3
71	451,5	571,5	486	443
80	471,5	591,5	495	451
90S	491,5	616,5	505	459
90L	516,5	641,5	505	459

Motorlar B14 flanş ile bağlanmıştır. / Motor connections are with IEC B14 Flange / Motor Befestigung mit IEC B14 Flansch.  
"k1" Ölçüsü frenli redüktörlere aittir. 56,63,71 tip elektrik motorlu redüktörler soğutmasız, diğerleri soğutmalıdır.  
Dimensions "k1" is for motors with brake. Gearboxes with 56,63,71 type electrical motors are not fan cooled, other types are fan cooled.  
Maße "k1" ist für Bremsenmotoren. Getrieben mit 56,63,71 typ Motoren sind ohne Kühlung, andere Typen zind mit Ventilator gekühlt.

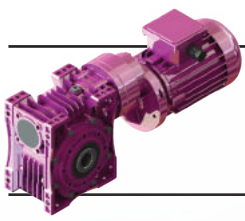

# Ölçü Sayfaları

## Dimension Pages

### Abmessungsseiten

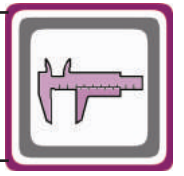

-Mil ucu çekirme deliği DIN 332 sayfa 2 / Tapped center hole to DIN 332, sheet 2 / Zentrierung mit Gewinde DIN 332, Blatt 2

EV050.□ - NR01

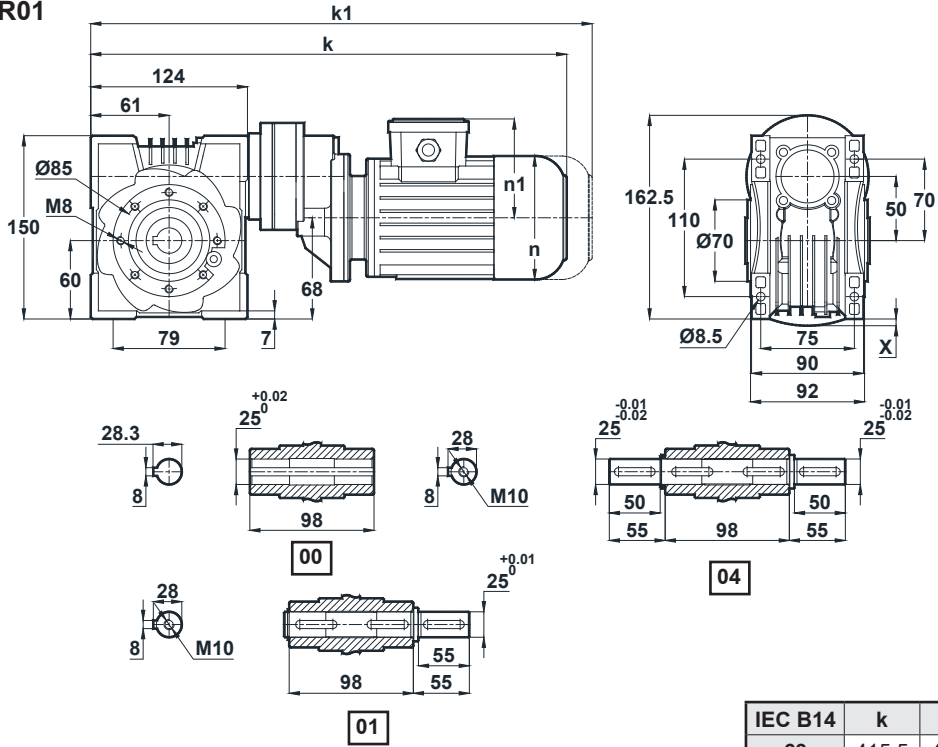

IEC B14	k	k1	n	n1	x
63	415,5	468,5	121	98	-
71	434,5	554,5	138	110	1
80	463	583	156	118	10
90S	491	616	176	126	20
90L	516	641	176	126	20

EV050.□ - NR01

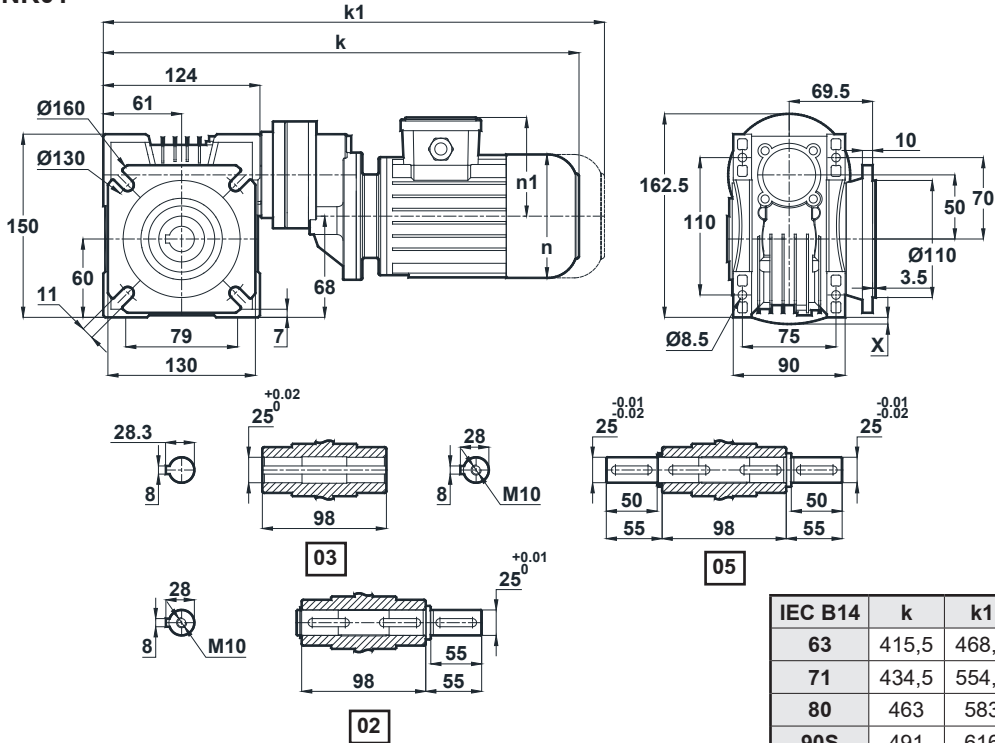

IEC B14	k	k1	n	n1	x
63	415,5	468,5	121	98	-
71	434,5	554,5	138	110	1
80	463	583	156	118	10
90S	491	616	176	126	20
90L	516	641	176	126	20

Motorlar B14 flans ile bağlanmıştır. / Motor connections are with IEC B14 Flange / Motor Befestigung mit IEC B14 Flansch.

"k1" Ölçüsü frenli redüktörlere aittir. 56,63,71 tip elektrik motorlu redüktörler soğutmasız, diğerleri soğutmalıdır.

Dimensions "k1" is for motors with brake. Gearboxes with 56,63,71 type electrical motors are not fan cooled, other types are fan cooled.

Maße "k1" ist für Bremsenmotoren. Getrieben mit 56,63,71 typ Motoren sind ohne Kühlung, andere Typen sind mit Ventilator gekühlt.

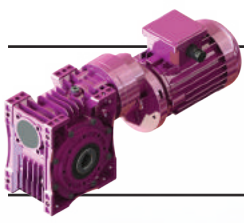

# Ölçü Sayfaları Dimension Pages Abmessungsseiten

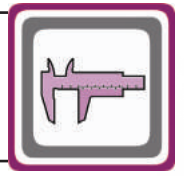

-Mil ucu çektirme deliği DIN 332 sayfa 2 / Tapped center hole to DIN 332, sheet 2 / Zentrierung mit Gewinde DIN 332, Blatt 2

EV063.□ - NR01

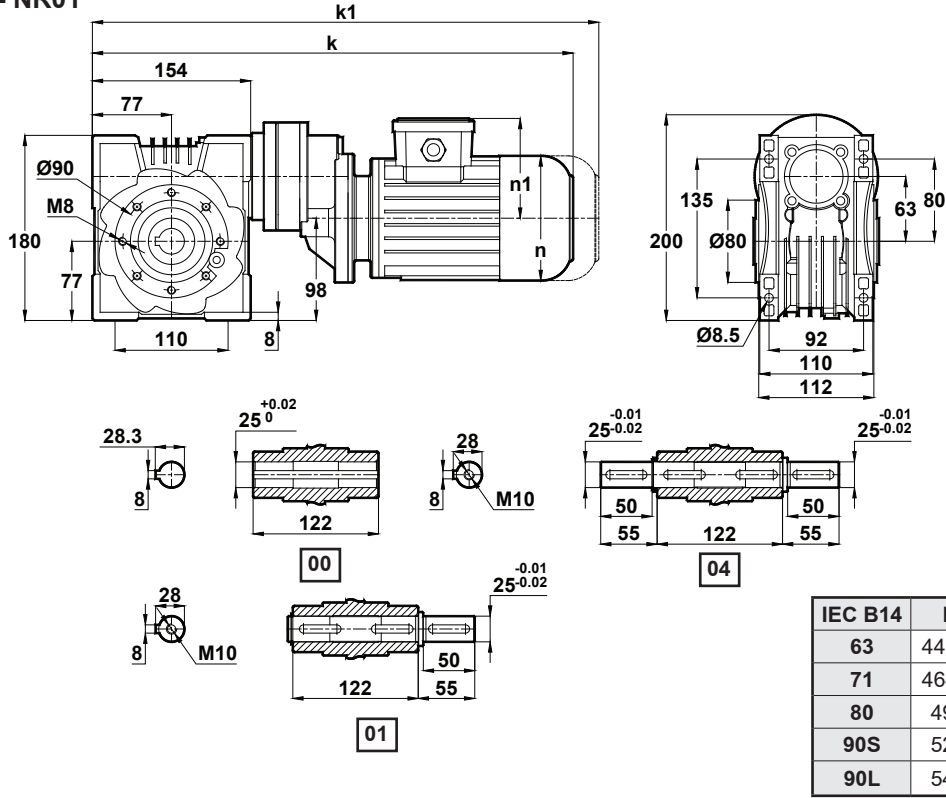

EV063.□ - NR01

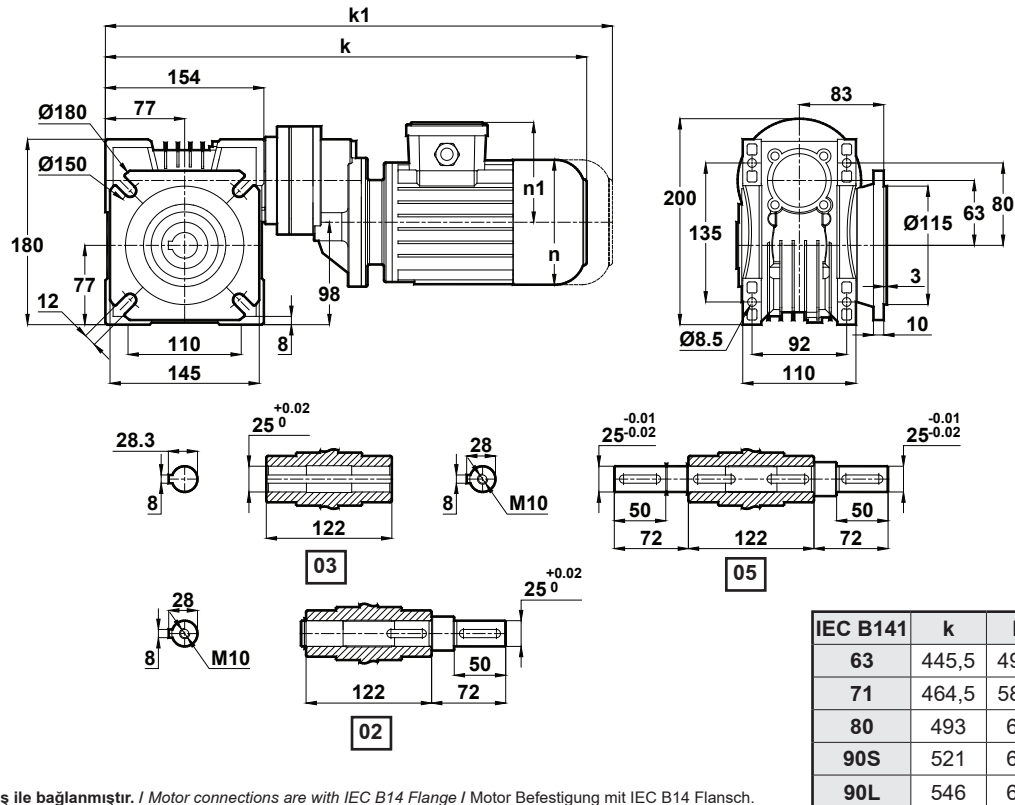

Motorlar B14 flanş ile bağlanmıştır. / Motor connections are with IEC B14 Flange / Motor Befestigung mit IEC B14 Flansch.

"k1" Ölçüsü frenli redüktörlere aittir. 56,63,71 tip elektrik motorlu redüktörler soğutmasız, diğerleri soğutmalıdır.

Dimensions "k1" is for motors with brake. Gearboxes with 56,63,71 type electrical motors are not fan cooled, other types are fan cooled.

Maße "k1" ist für Bremsenmotoren. Getrieben mit 56,63,71 typ Motoren sind ohne Kühlung, andere Typen zind mit Ventilator gekühlt.

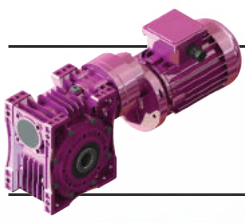

# Ölçü Sayfaları

## Dimension Pages

### Abmessungsseiten

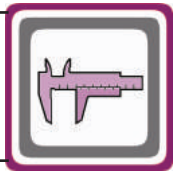

-Mil ucu çekirme deliği DIN 332 sayfa 2 / Tapped center hole to DIN 332, sheet 2 / Zentrierung mit Gewinde DIN 332, Blatt 2

EV075.□ - NR11

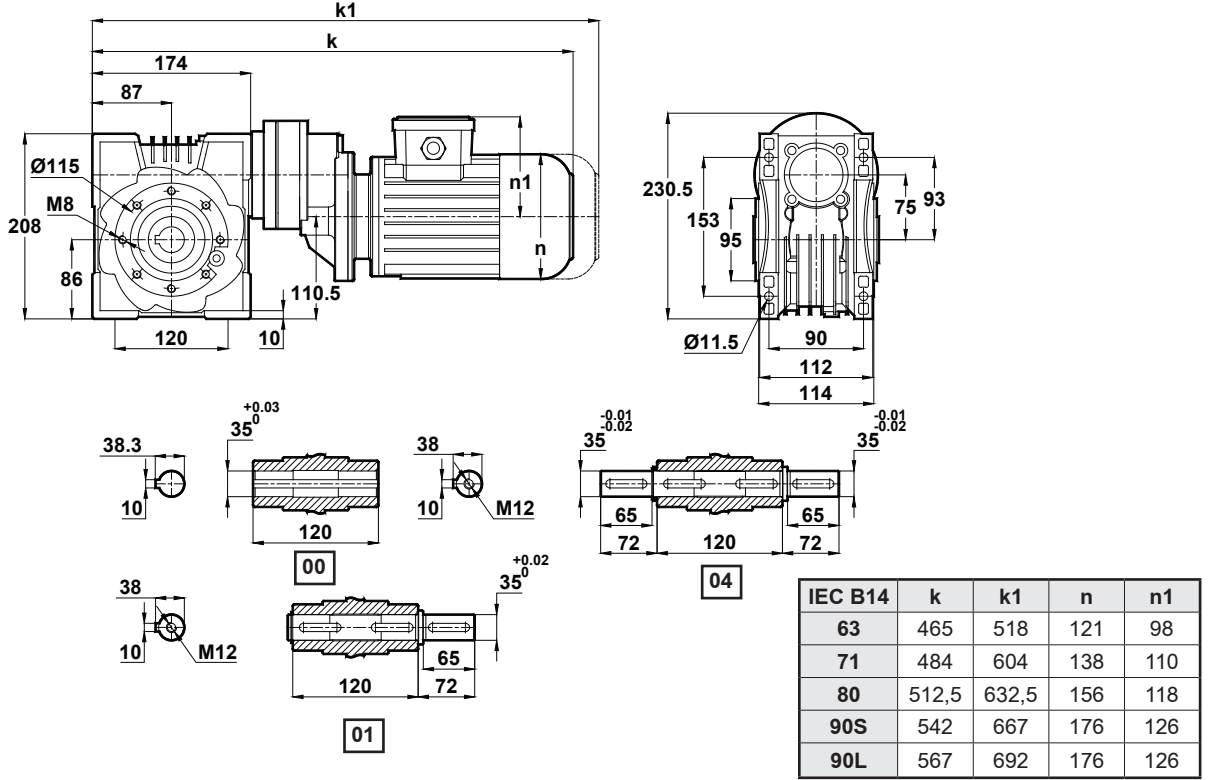

EV075.□ - NR11

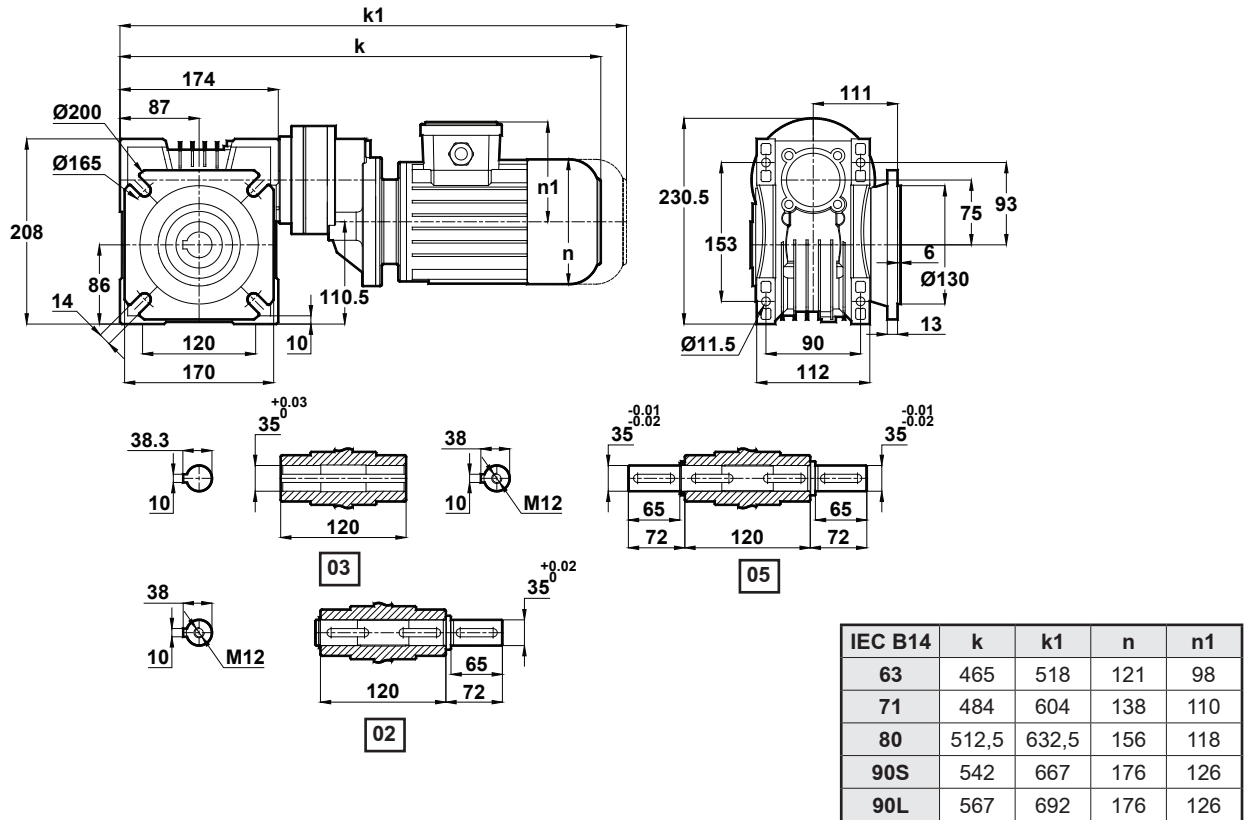

Motorlar B14 flans ile bağlanmıştır. / Motor connections are with IEC B14 Flange / Motor Befestigung mit IEC B14 Flansch.

"k1" Ölçüsü frenli redüktörlere aittir. 56,63,71 tip elektrik motorlu redüktörler soğutmasız, diğerleri soğutmalıdır.

Dimensions "k1" is for motors with brake. Gearboxes with 56,63,71 type electrical motors are not fan cooled, other types are fan cooled.

Maße "k1" ist für Bremsenmotoren. Getrieben mit 56,63,71 typ Motoren sind ohne Kühlung, andere Typen sind mit Ventilator gekühlt.

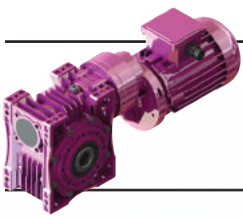

# Ölçü Sayfaları

## Dimension Pages

### Abmessungsseiten

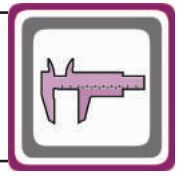

-Mil ucu çektirme deliği DIN 332 sayfa 2 / Tapped center hole to DIN 332, sheet 2 / Zentrierung mit Gewinde DIN 332, Blatt 2

EV080.□ - NR11

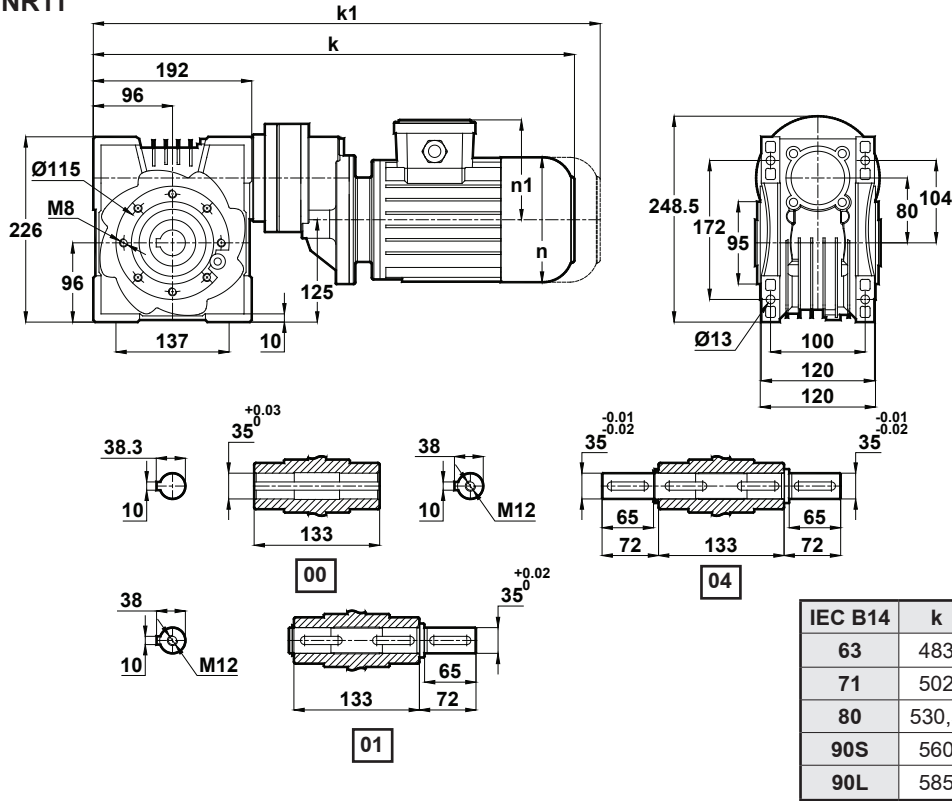

EV080.□ - NR11

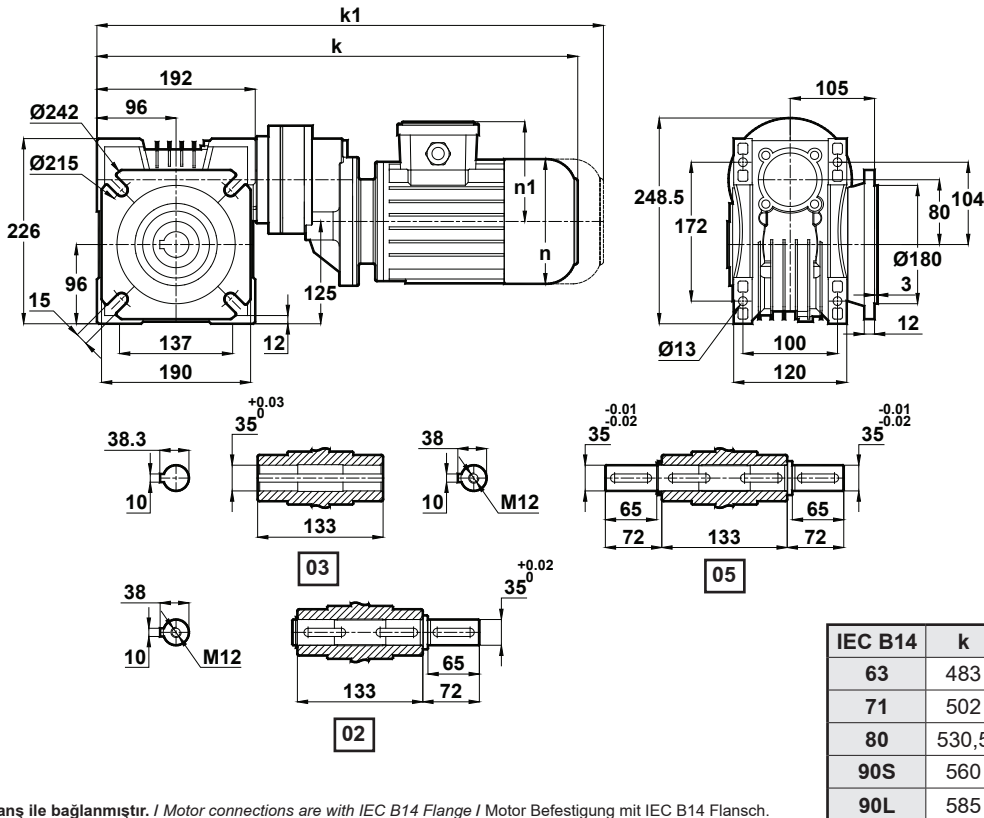

Motorlar B14 flanş ile bağlanmıştır. / Motor connections are with IEC B14 Flange / Motor Befestigung mit IEC B14 Flansch.

"k1" Ölçüsü frenli redüktörlere aittir. 56,63,71 tip elektrik motorlu redüktörler soğutmasız, diğerleri soğutmalıdır.

Dimensions "k1" is for motors with brake. Gearboxes with 56,63,71 type electrical motors are not fan cooled, other types are fan cooled.

Maße "k1" ist für Bremsenmotoren. Getrieben mit 56,63,71 typ Motoren sind ohne Kühlung, andere Typen zind mit Ventilator gekühlt.



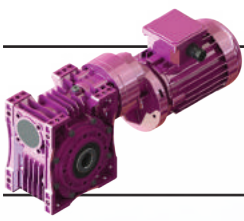

# Ölçü Sayfaları

## Dimension Pages

### Abmessungsseiten

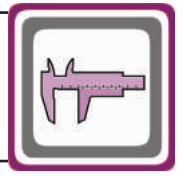

-Mil ucu çektirme deliği DIN 332 sayfa 2 / Tapped center hole to DIN 332, sheet 2 / Zentrierung mit Gewinde DIN 332, Blatt 2

EV125.□ - NR21

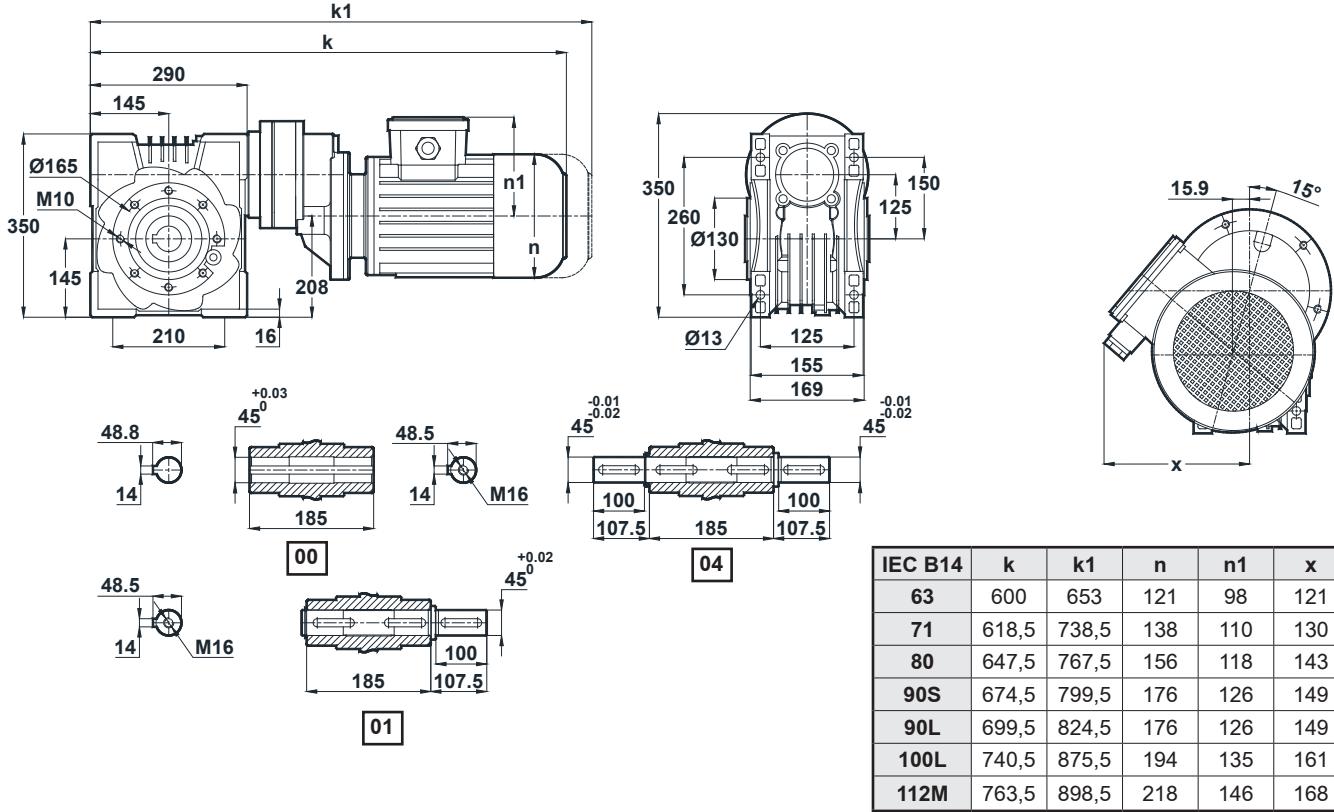

EV125.□ - NR21

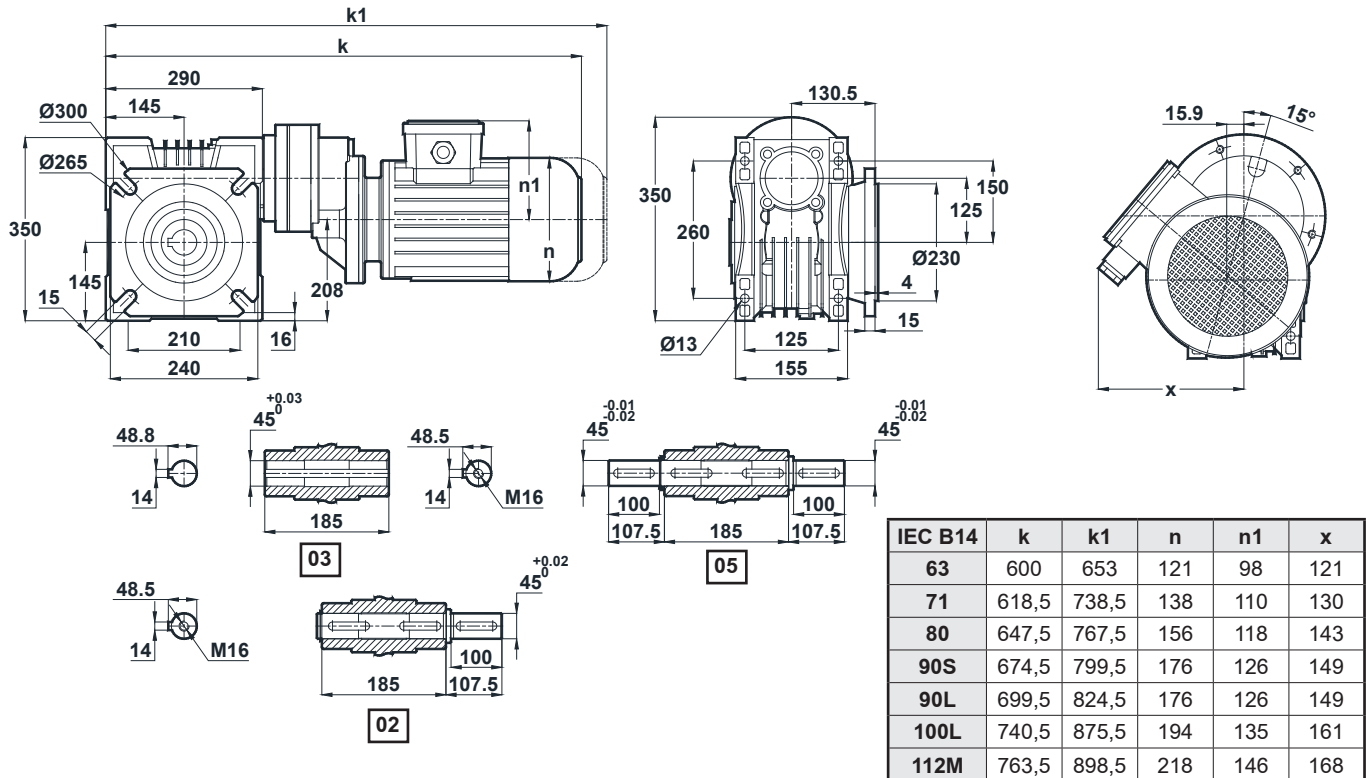

Motorlar B14 flanş ile bağlanmıştır. / Motor connections are with IEC B14 Flange / Motor Befestigung mit IEC B14 Flansch.

"k1" Ölçüsü frenli redüktörlere aittir. 56,63,71 tip elektrik motorlu redüktörler soğutmasız, diğerleri soğutmalıdır.

Dimensions "k1" is for motors with brake. Gearboxes with 56,63,71 type electrical motors are not fan cooled, other types are fan cooled.

Maße "k1" ist für Bremsmotoren. Getrieben mit 56,63,71 typ Motoren sind ohne Kühlung, andere Typen sind mit Ventilator gekühlt.

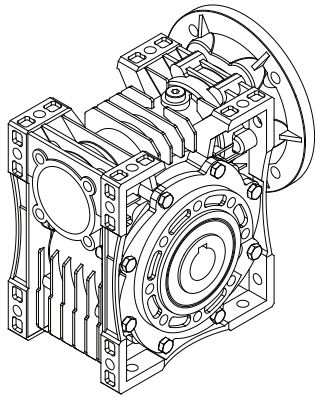

**EN...00**

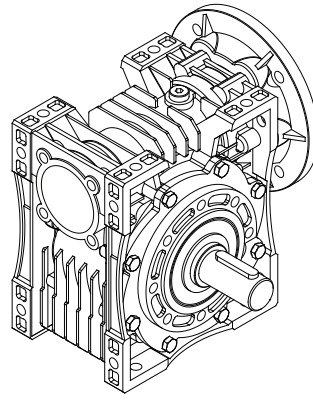

**EN...01**

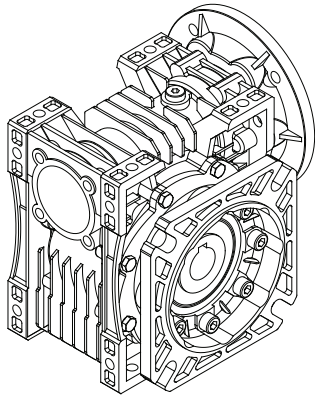

**EN...02**

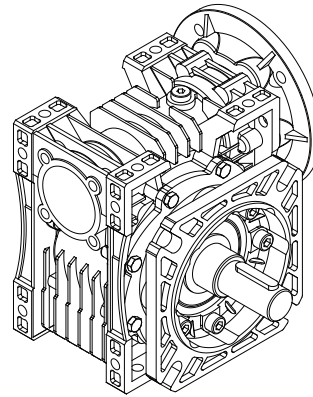

**EN...03**

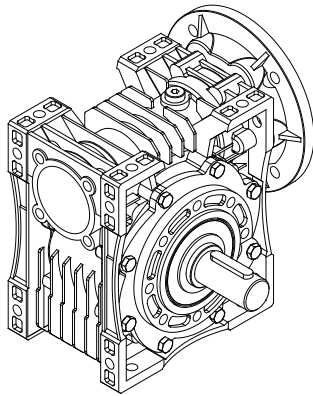

**EN...04**

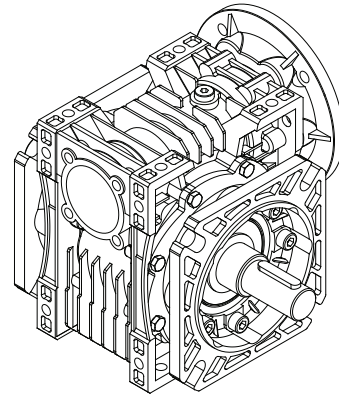

**EN...05**

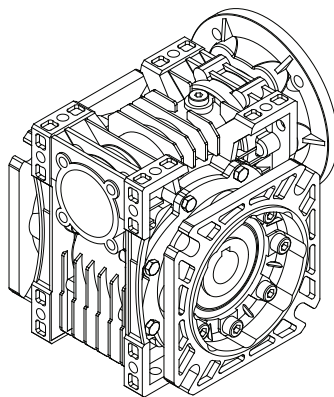

**EN...08**



# Ölçü Sayfaları Dimension Pages Abmessungsseiten



-Mil ucu çekirme deliği DIN 332 sayfa 2 / Tapped center hole to DIN 332, sheet 2 / Zentrierung mit Gewinde DIN 332, Blatt 2

## EN030.00

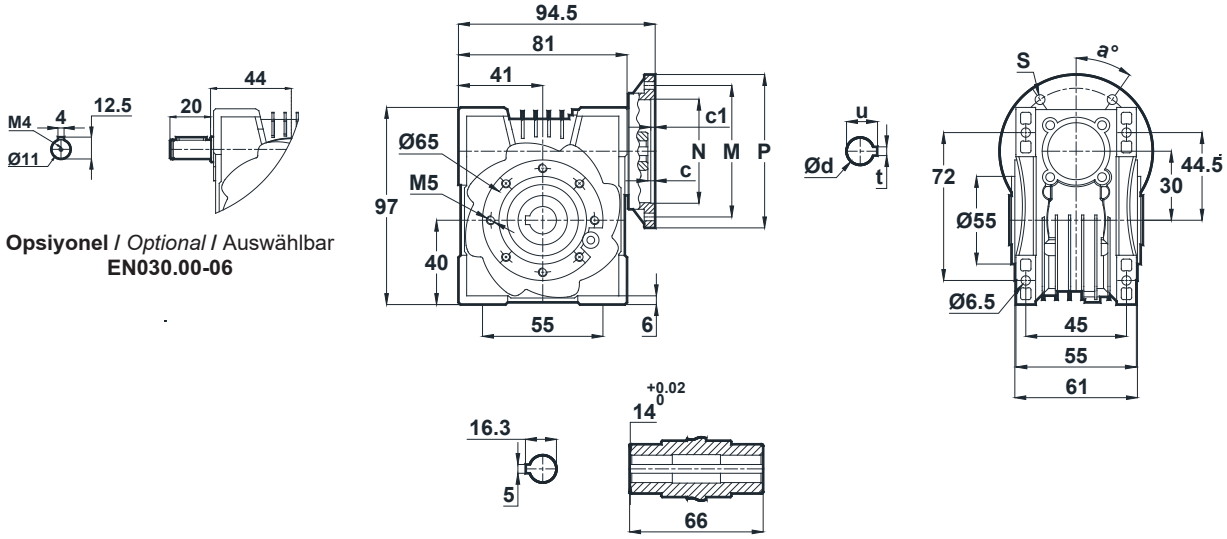

Opsiyonel / Optional / Auswählbar  
EN030.00-06

## EN030.01

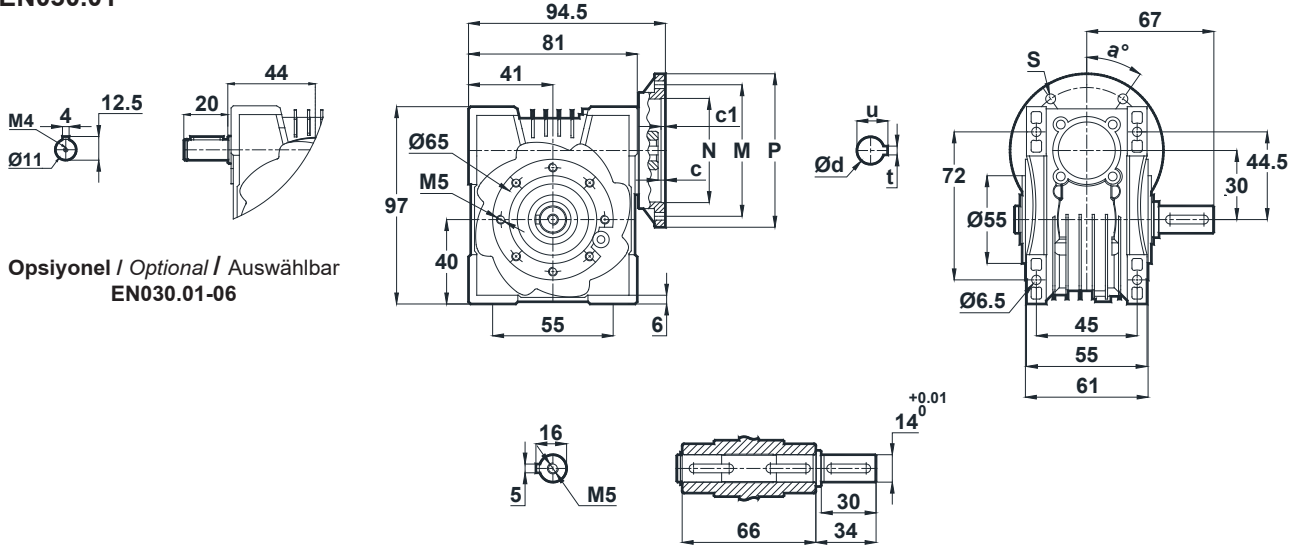

Opsiyonel / Optional / Auswählbar  
EN030.01-06

EN030	c	c1	N	M	P	d	u	t	a	s
56/B14	4,2	3	50	65	80	9	10,4	3	45°	5,5
63/B14	4,2	3	60	75	90	11	12,8	4	45°	5,5
63/B5	4,2	3,5	95	115	140	11	12,8	4	45°	10





# Ölçü Sayfaları

## Dimension Pages

### Abmessungsseiten



-Mil ucu çekirme deliği DIN 332 sayfa 2 / Tapped center hole to DIN 332, sheet 2 / Zentrierung mit Gewinde DIN 332, Blatt 2

#### EN030.04

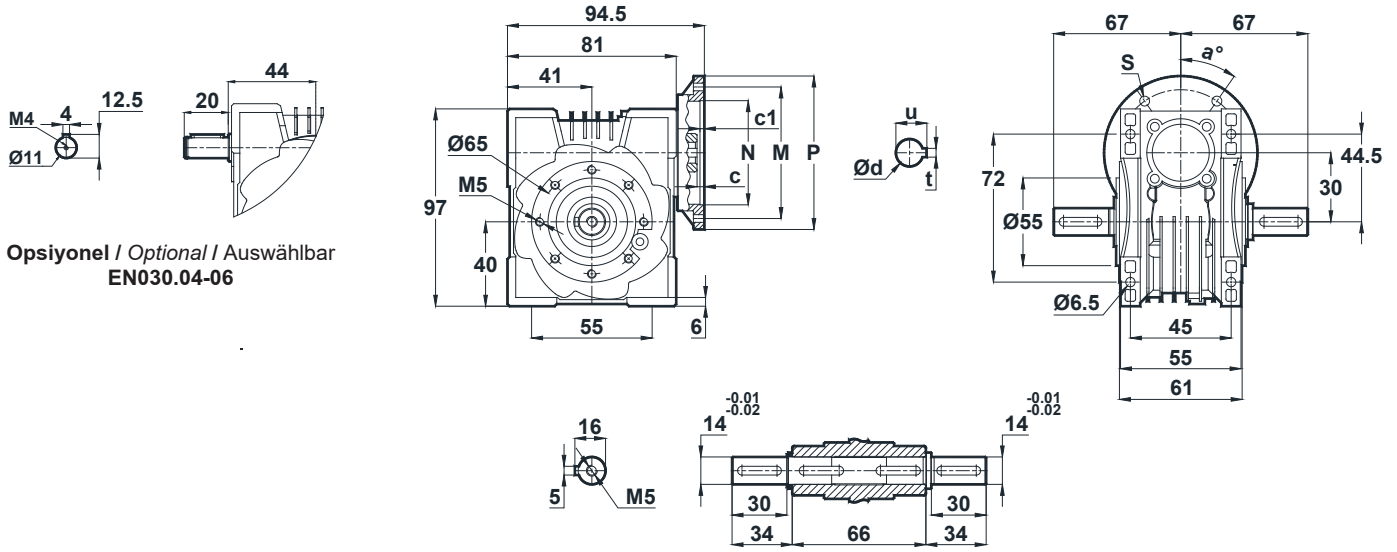

#### EN030.05

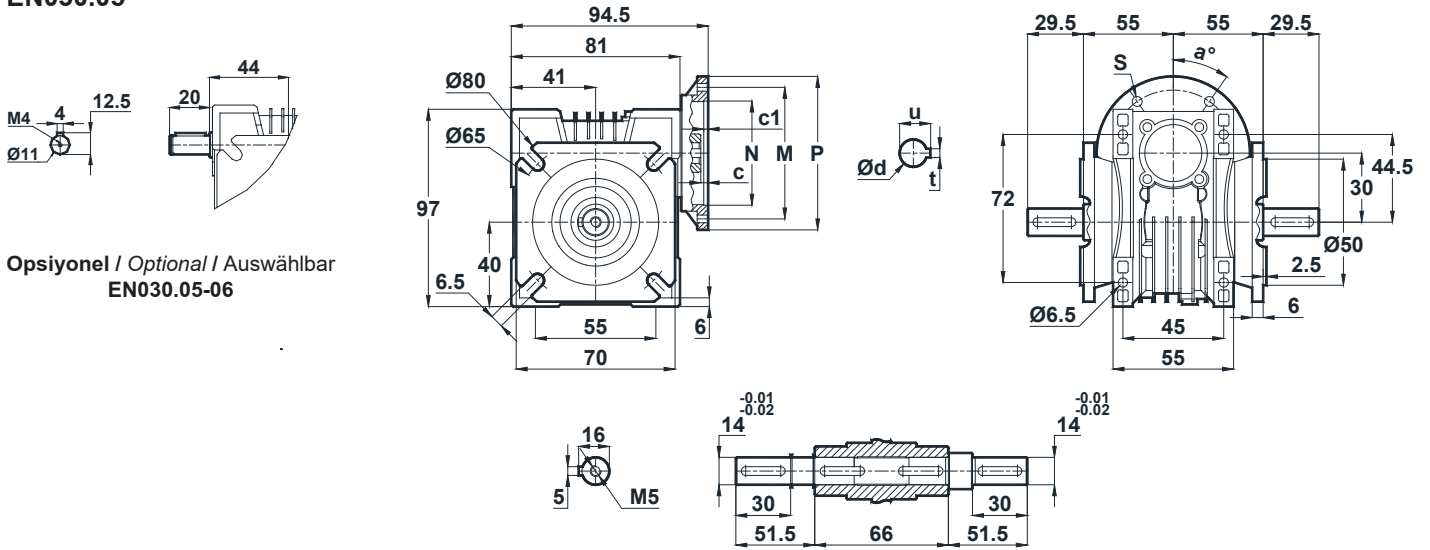

EN030	c	c1	N	M	P	d	u	t	a	s
56/B14	4,2	3	50	65	80	9	10,4	3	45°	5,5
63/B14	4,2	3	60	75	90	11	12,8	4	45°	5,5
63/B5	4,2	3,5	95	115	140	11	12,8	4	45°	10



# Ölçü Sayfaları

## Dimension Pages

### Abmessungsseiten



-Mil ucu çekirme deliği DIN 332 sayfa 2 / Tapped center hole to DIN 332, sheet 2 / Zentrierung mit Gewinde DIN 332, Blatt 2

EN030.08

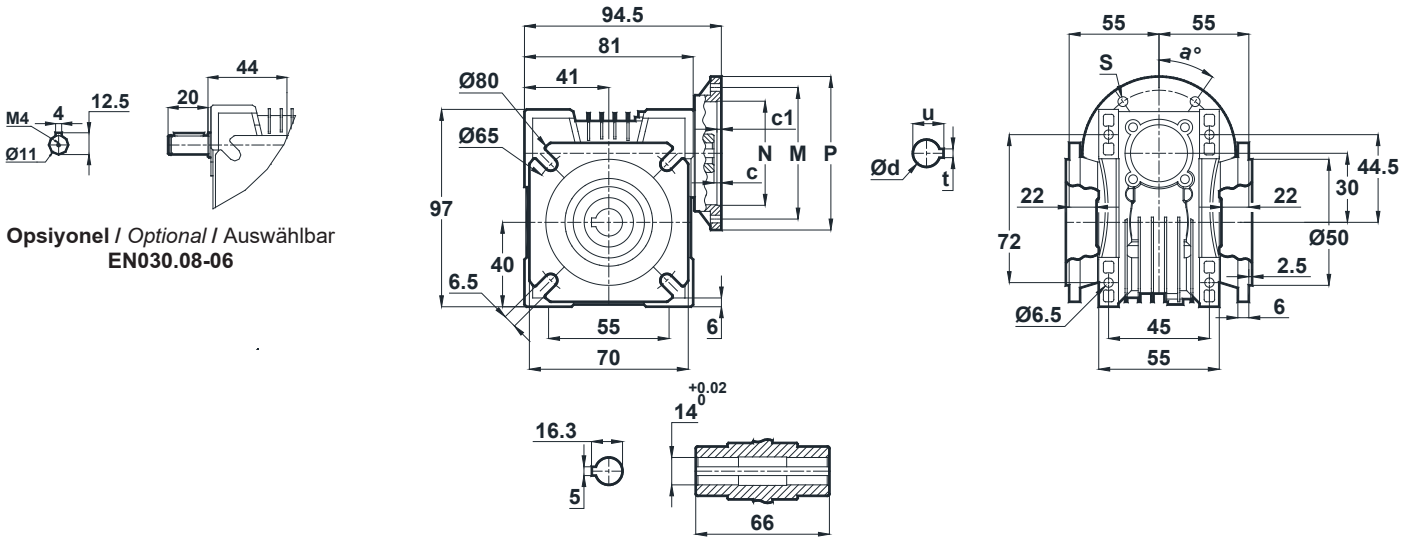

Opsiyonel / Optional / Auswählbar  
EN030.08-06

EN030	c	c1	N	M	P	d	u	t	a	s
56/B14	4,2	3	50	65	80	9	10,4	3	45°	5,5
63/B14	4,2	3	60	75	90	11	12,8	4	45°	5,5
63/B5	4,2	3,5	95	115	140	11	12,8	4	45°	10



# Ölçü Sayfaları

## Dimension Pages

### Abmessungsseiten



-Mil ucu çekirme deliği DIN 332 sayfa 2 / Tapped center hole to DIN 332, sheet 2 / Zentrierung mit Gewinde DIN 332, Blatt 2

#### EN040.00

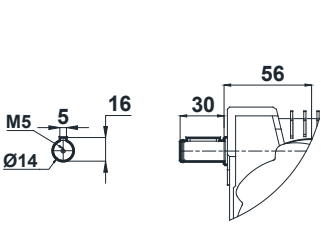

Opsiyonel / Optional / Auswählbar  
EN040.00-06

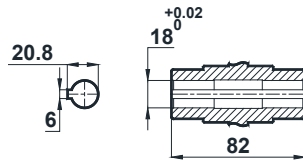
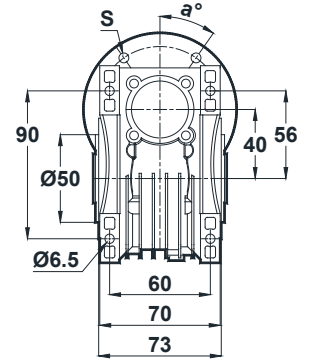
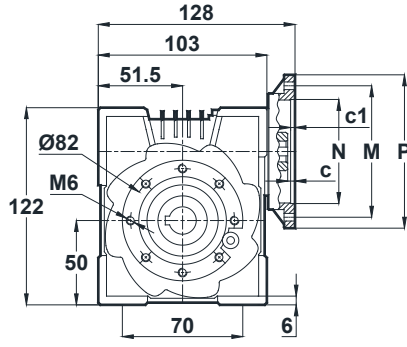

#### EN040.01

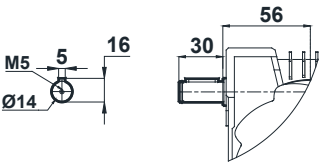

Opsiyonel / Optional / Auswählbar  
EN040.01-06

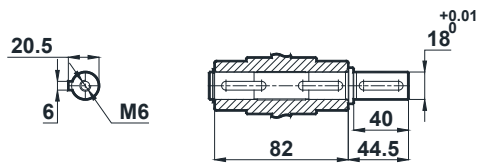
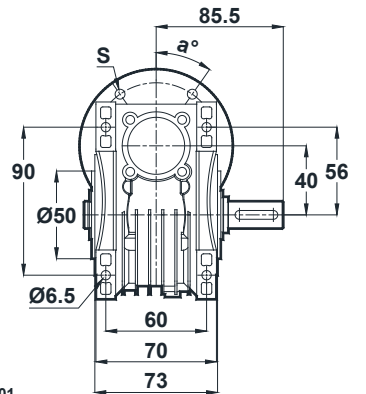
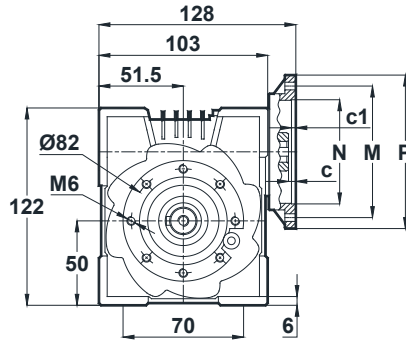

EN040	c	c1	N	M	P	d	u	t	a	s
63/B14	4	2,5	60	75	90	11	12,8	4	45°	5,5
71/B14	4	2,5	70	85	105	14	16,3	5	45°	10
63/B5	4	3,5	95	115	140	11	12,8	4	45°	10
71/B5	4	4	110	130	160	14	16,3	5	45°	10



# Ölçü Sayfaları Dimension Pages Abmessungsseiten



-Mil ucu çekirme deliği DIN 332 sayfa 2 / Tapped center hole to DIN 332, sheet 2 / Zentrierung mit Gewinde DIN 332, Blatt 2

## EN040.02

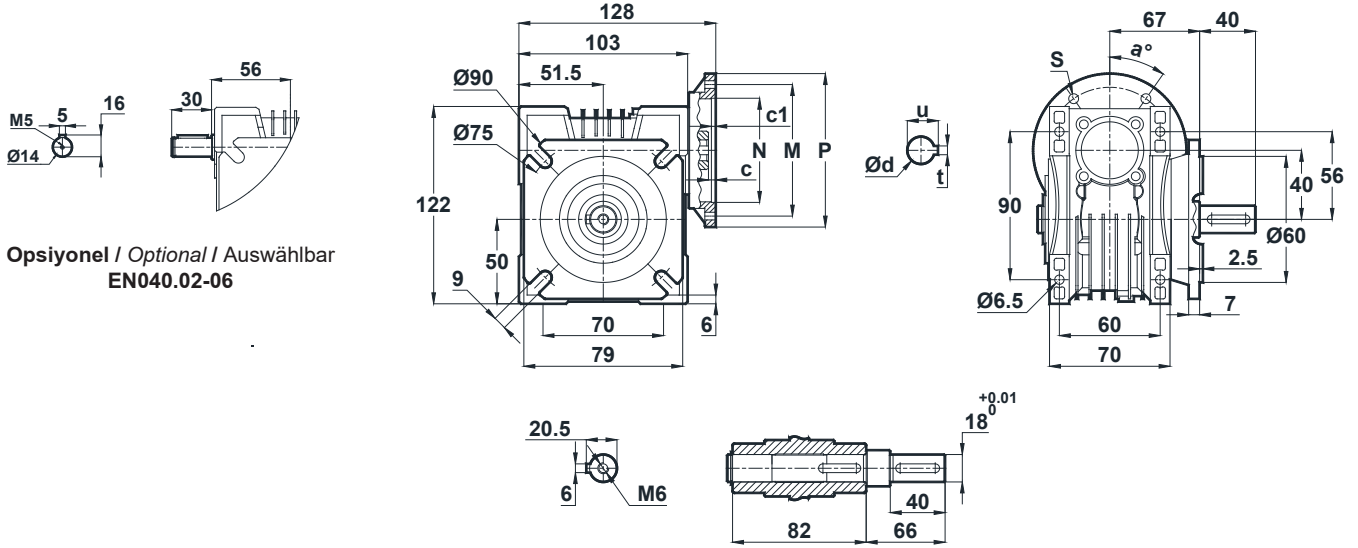

Opsiyonel / Optional / Auswählbar  
EN040.02-06

## EN040.03

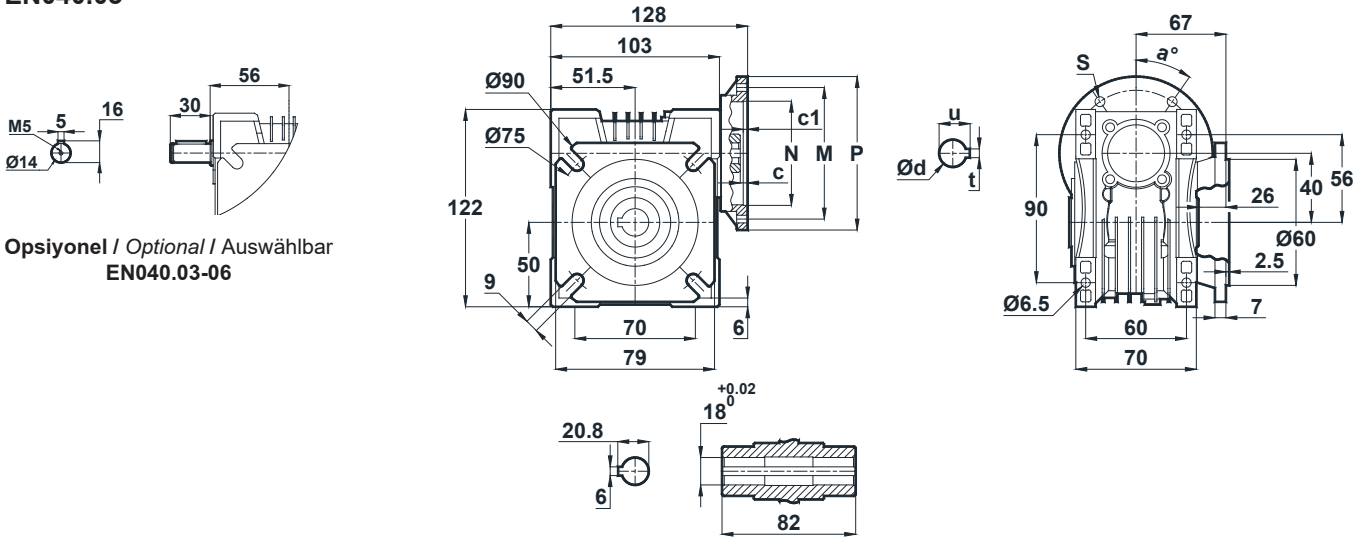

Opsiyonel / Optional / Auswählbar  
EN040.03-06

EN040	c	c1	N	M	P	d	u	t	a	s
63/B14	4	2,5	60	75	90	11	12,8	4	45°	5,5
71/B14	4	2,5	70	85	105	14	16,3	5	45°	10
63/B5	4	3,5	95	115	140	11	12,8	4	45°	10
71/B5	4	4	110	130	160	14	16,3	5	45°	10



# Ölçü Sayfaları

## Dimension Pages

### Abmessungsseiten



-Mil ucu çekirme deliği DIN 332 sayfa 2 / Tapped center hole to DIN 332, sheet 2 / Zentrierung mit Gewinde DIN 332, Blatt 2

#### EN040.04

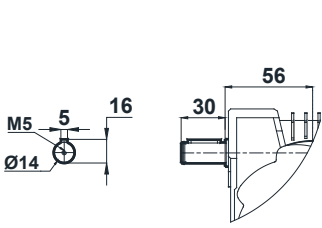

Opsiyonel / Optional / Auswählbar  
EN040.04-06

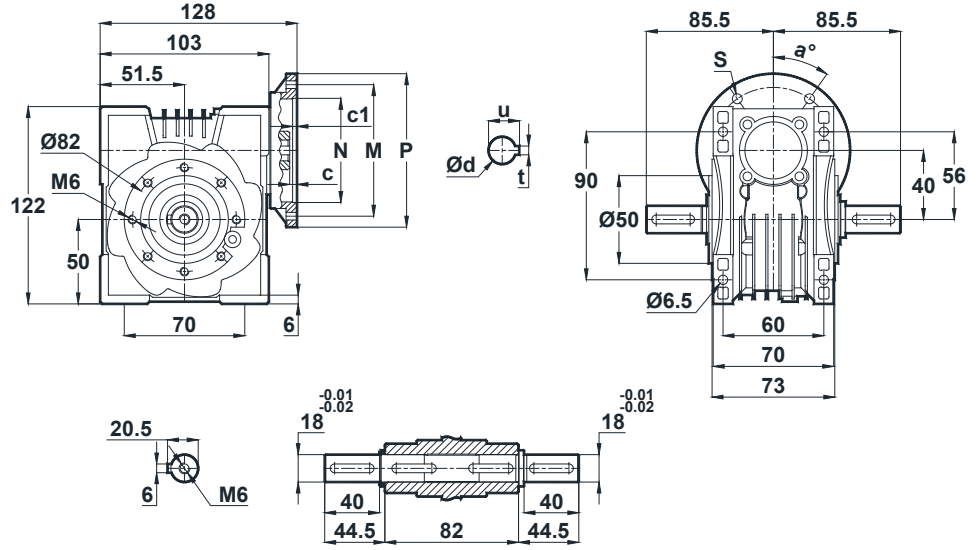

#### EN040.05

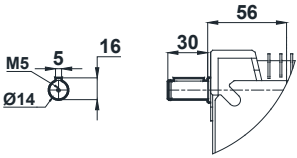

Opsiyonel / Optional / Auswählbar  
EN040.05-06

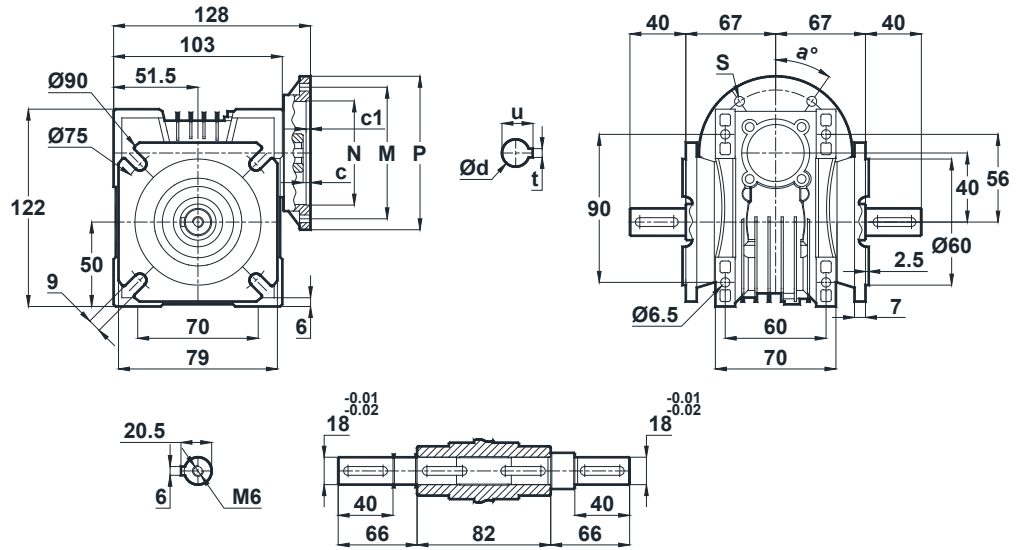

EN040	c	c1	N	M	P	d	u	t	a	s
63/B14	4	2,5	60	75	90	11	12,8	4	45°	5,5
71/B14	4	2,5	70	85	105	14	16,3	5	45°	10
63/B5	4	3,5	95	115	140	11	12,8	4	45°	10
71/B5	4	4	110	130	160	14	16,3	5	45°	10



# Ölçü Sayfaları

## Dimension Pages

### Abmessungsseiten



-Mil ucu çekirme deliği DIN 332 sayfa 2 / Tapped center hole to DIN 332, sheet 2 / Zentrierung mit Gewinde DIN 332, Blatt 2

#### EN040.08

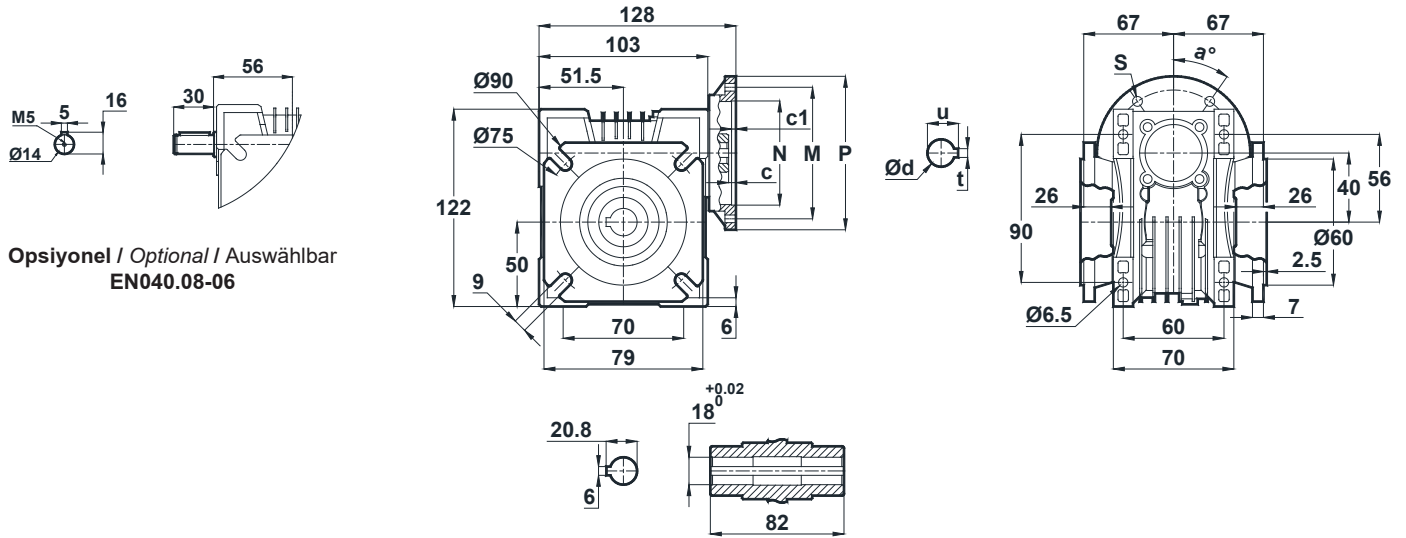

Opsiyonel / Optional / Auswählbar  
EN040.08-06

EN040	c	c1	N	M	P	d	u	t	a	s
63/B14	4	2,5	60	75	90	11	12,8	4	45°	5,5
71/B14	4	2,5	70	85	105	14	16,3	5	45°	10
63/B5	4	3,5	95	115	140	11	12,8	4	45°	10
71/B5	4	4	110	130	160	14	16,3	5	45°	10



# Ölçü Sayfaları

## Dimension Pages

### Abmessungsseiten



-Mil ucu çekirme deliği DIN 332 sayfa 2 / Tapped center hole to DIN 332, sheet 2 / Zentrierung mit Gewinde DIN 332, Blatt 2

#### EN050.00

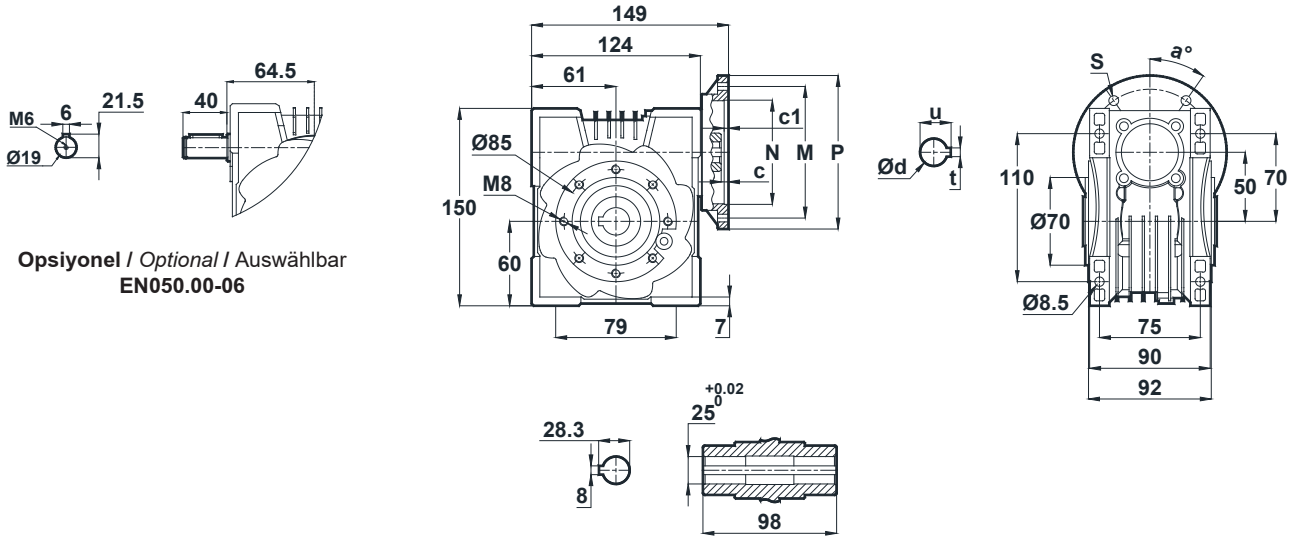

#### EN050.01

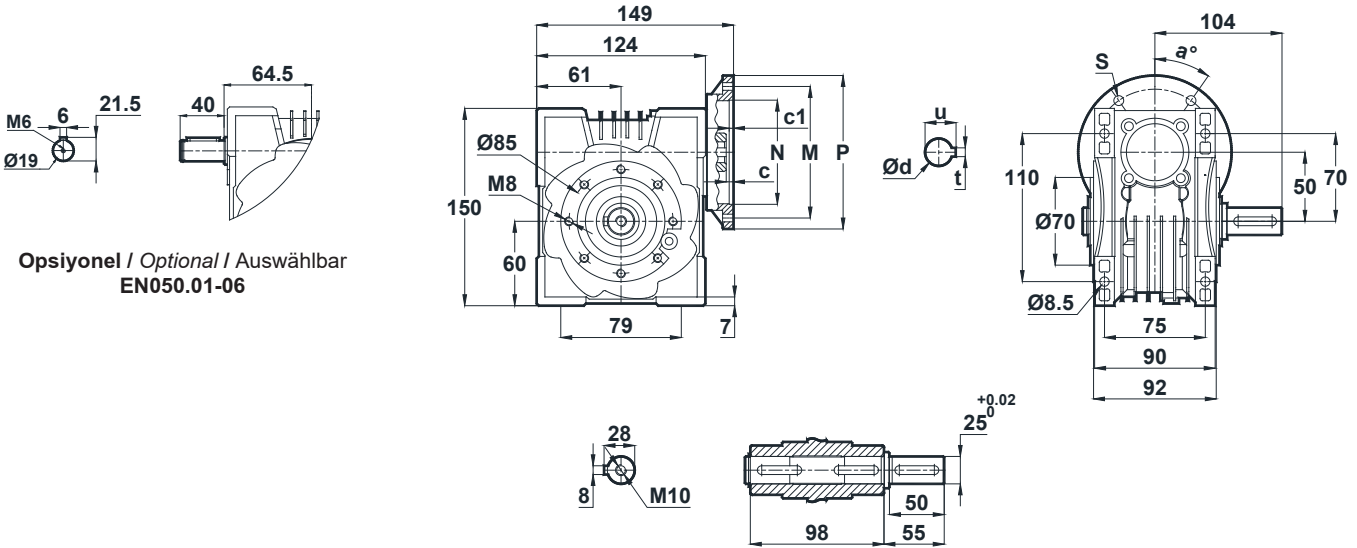

EN050	c	c1	N	M	P	d	u	t	a	s
71/B14	10,7	3	70	85	105	14	16,3	5	15°	7
80/B14	10,7	4	80	100	120	19	21,8	6	15°	7
90/B14	10,7	4,5	95	115	140	24	27,3	8	15°	9
63/B5	10,7	4,5	95	115	140	11	12,8	4	45°	10
71/B5	10,7	4,5	110	130	160	14	16,3	5	15°	10
80/B5	10,7	4,5	130	165	200	19	21,8	6	15°	12
90/B5	10,7	4,5	130	165	200	24	27,3	8	15°	12



# Ölçü Sayfaları Dimension Pages Abmessungsseiten



-Mil ucu çekirme deliği DIN 332 sayfa 2 / Tapped center hole to DIN 332, sheet 2 / Zentrierung mit Gewinde DIN 332, Blatt 2

## EN050.02

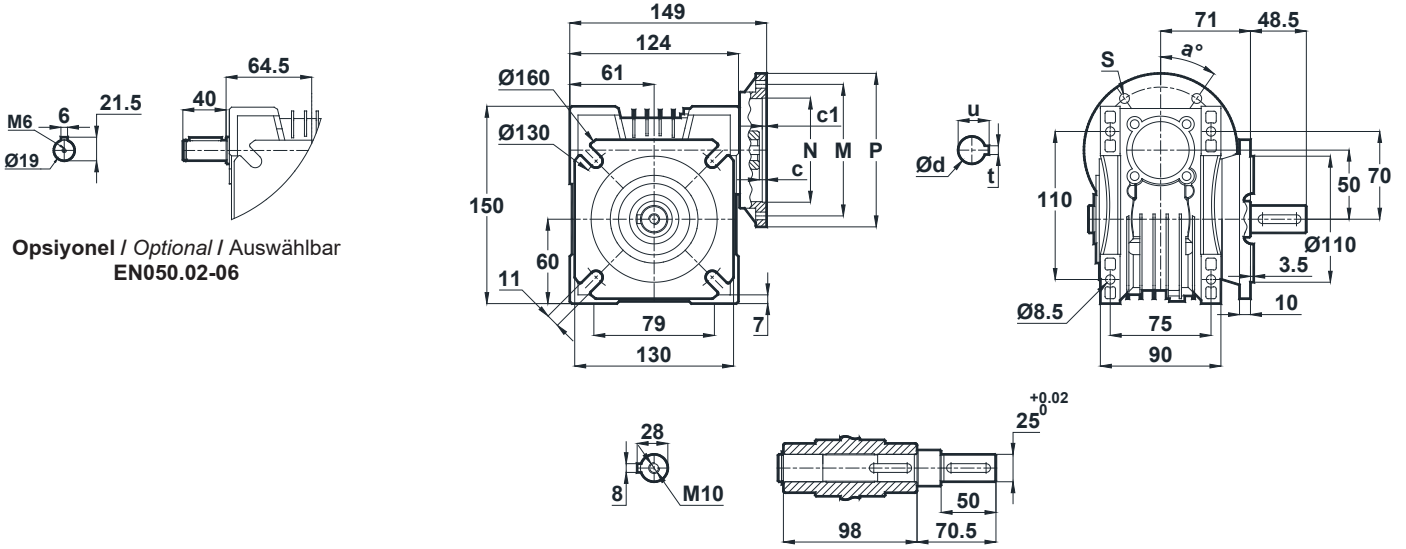

## EN050.03

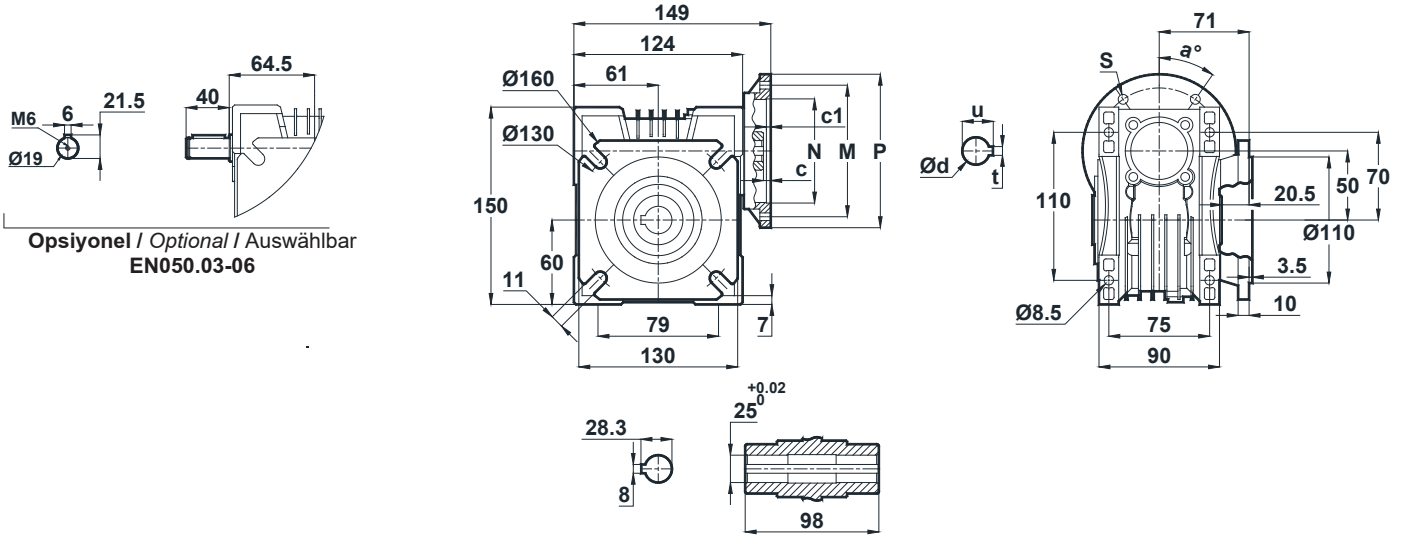

EN050	c	c1	N	M	P	d	u	t	a	s
71/B14	10,7	3	70	85	105	14	16,3	5	15°	7
80/B14	10,7	4	80	100	120	19	21,8	6	15°	7
90/B14	10,7	4,5	95	115	140	24	27,3	8	15°	9
63/B5	10,7	4,5	95	115	140	11	12,8	4	45°	10
71/B5	10,7	4,5	110	130	160	14	16,3	5	15°	10
80/B5	10,7	4,5	130	165	200	19	21,8	6	15°	12
90/B5	10,7	4,5	130	165	200	24	27,3	8	15°	12



# Ölçü Sayfaları Dimension Pages Abmessungsseiten



-Mil ucu çekirme deliği DIN 332 sayfa 2 / Tapped center hole to DIN 332, sheet 2 / Zentrierung mit Gewinde DIN 332, Blatt 2

## EN050.04

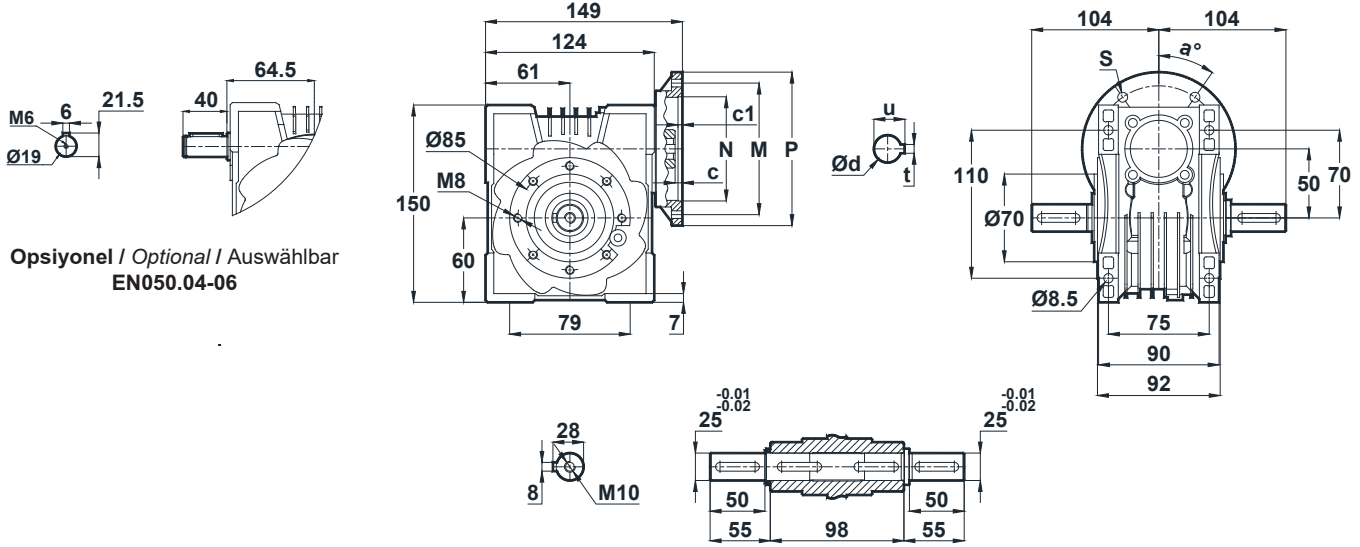

Opsiyonel / Optional / Auswählbar  
EN050.04-06

## EN050.05

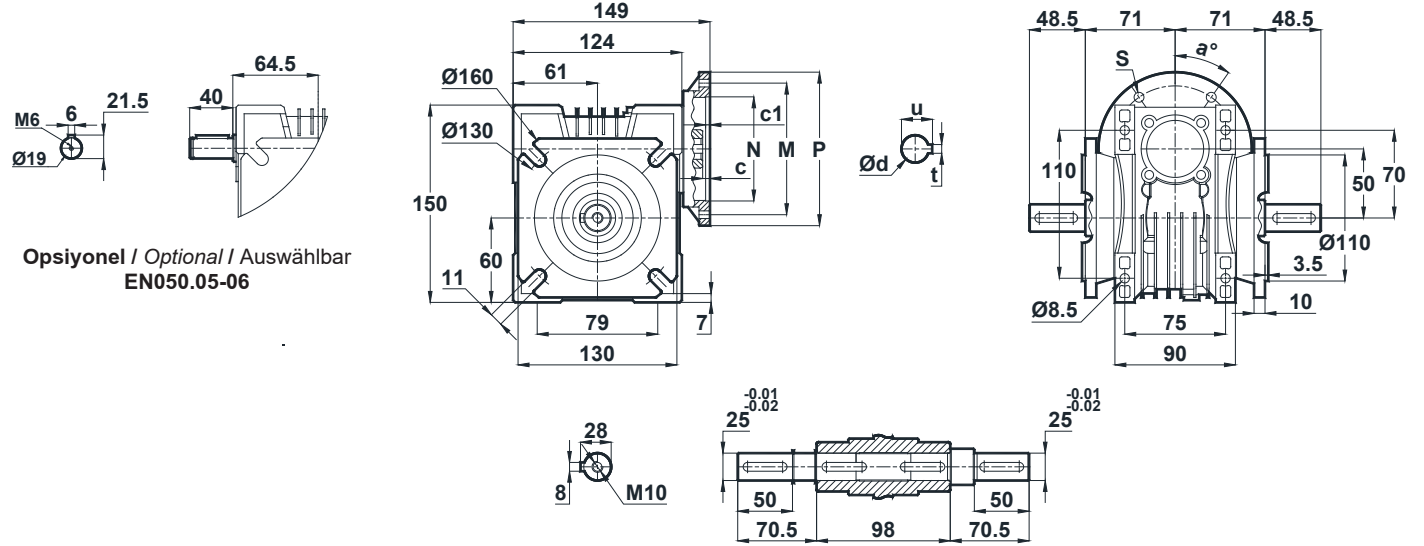

Opsiyonel / Optional / Auswählbar  
EN050.05-06

EN050	c	c1	N	M	P	d	u	t	a	s
71/B14	10,7	3	70	85	105	14	16,3	5	15°	7
80/B14	10,7	4	80	100	120	19	21,8	6	15°	7
90/B14	10,7	4,5	95	115	140	24	27,3	8	15°	9
63/B5	10,7	4,5	95	115	140	11	12,8	4	45°	10
71/B5	10,7	4,5	110	130	160	14	16,3	5	15°	10
80/B5	10,7	4,5	130	165	200	19	21,8	6	15°	12
90/B5	10,7	4,5	130	165	200	24	27,3	8	15°	12



# Ölçü Sayfaları

## Dimension Pages

### Abmessungsseiten



-Mil ucu çekirme deliği DIN 332 sayfa 2 / Tapped center hole to DIN 332, sheet 2 / Zentrierung mit Gewinde DIN 332, Blatt 2

#### EN050.08

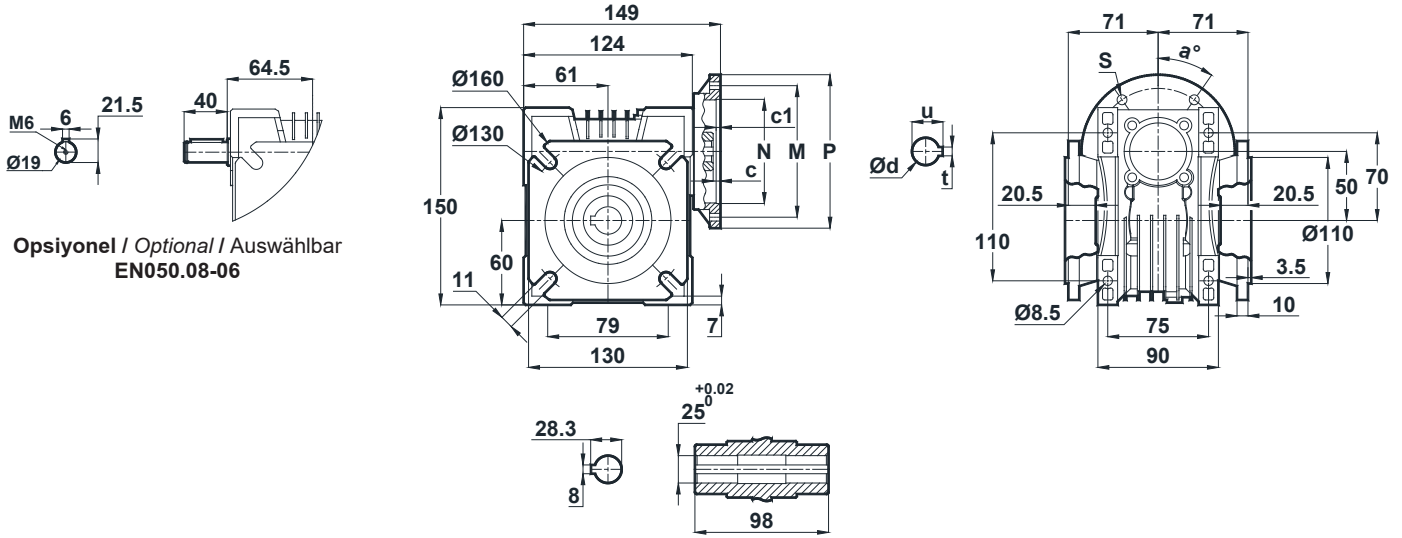

EN050	c	c1	N	M	P	d	u	t	a	s
71/B14	10,7	3	70	85	105	14	16,3	5	15°	7
80/B14	10,7	4	80	100	120	19	21,8	6	15°	7
90/B14	10,7	4,5	95	115	140	24	27,3	8	15°	9
63/B5	10,7	4,5	95	115	140	11	12,8	4	45°	10
71/B5	10,7	4,5	110	130	160	14	16,3	5	15°	10
80/B5	10,7	4,5	130	165	200	19	21,8	6	15°	12
90/B5	10,7	4,5	130	165	200	24	27,3	8	15°	12



# Ölçü Sayfaları Dimension Pages Abmessungsseiten



-Mil ucu çekirme deliği DIN 332 sayfa 2 / Tapped center hole to DIN 332, sheet 2 / Zentrierung mit Gewinde DIN 332, Blatt 2

## EN063.00

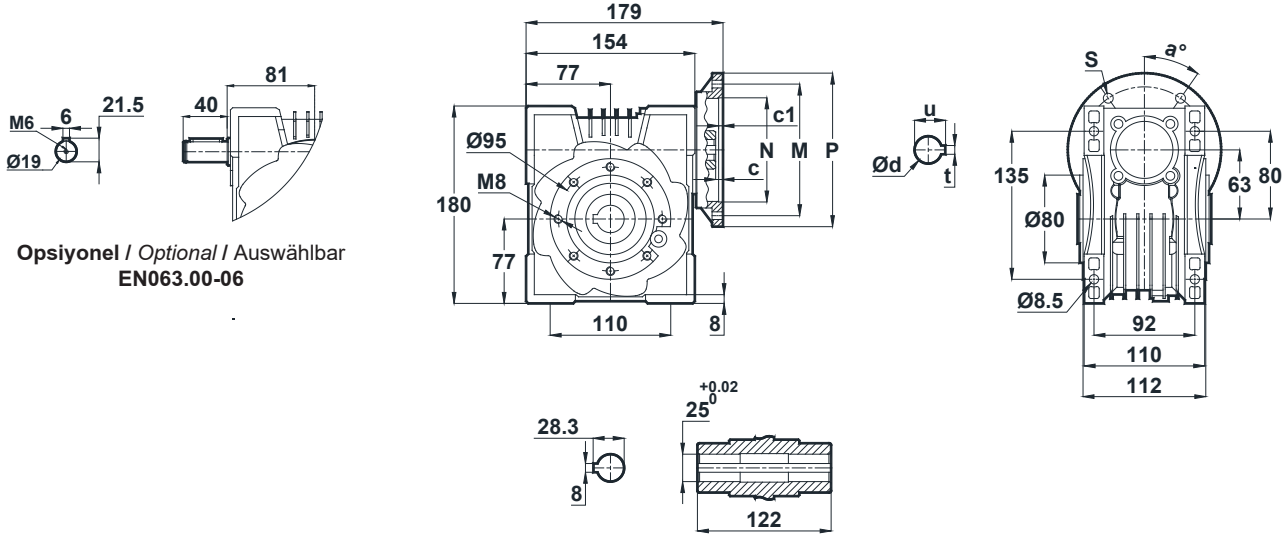

Opsiyonel / Optional / Auswählbar  
EN063.00-06

## EN063.01

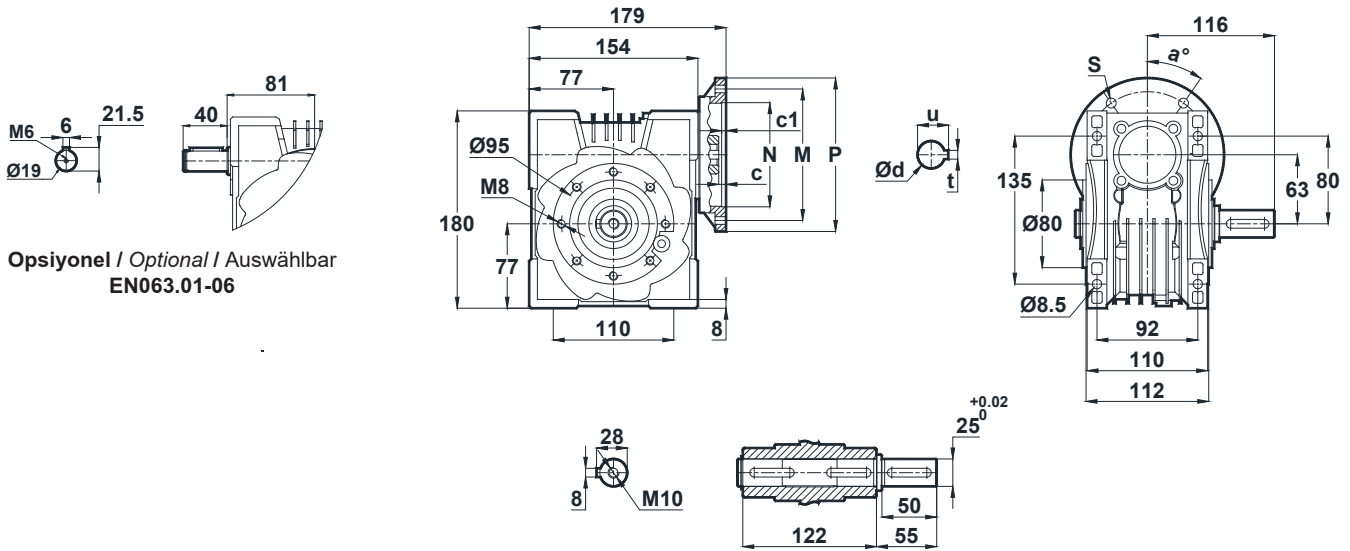

Opsiyonel / Optional / Auswählbar  
EN063.01-06

EN075	c	c1	N	M	P	d	u	t	a	s
71/B14	5,7	3	70	85	105	14	16,3	5	45°	7
80/B14	5,7	4	80	100	120	19	21,8	6	15°	7
90/B14	5,7	4,5	95	115	140	24	27,3	8	15°	9
71/B5	5,7	4,5	110	130	160	14	16,3	5	15°	10
80/B5	5,7	4,5	130	165	200	19	21,8	6	15°	12
90/B5	5,7	4,5	130	165	200	24	27,3	8	15°	12



# Ölçü Sayfaları

## Dimension Pages

### Abmessungsseiten



-Mil ucu çekirme deliği DIN 332 sayfa 2 / Tapped center hole to DIN 332, sheet 2 / Zentrierung mit Gewinde DIN 332, Blatt 2

#### EN063.02

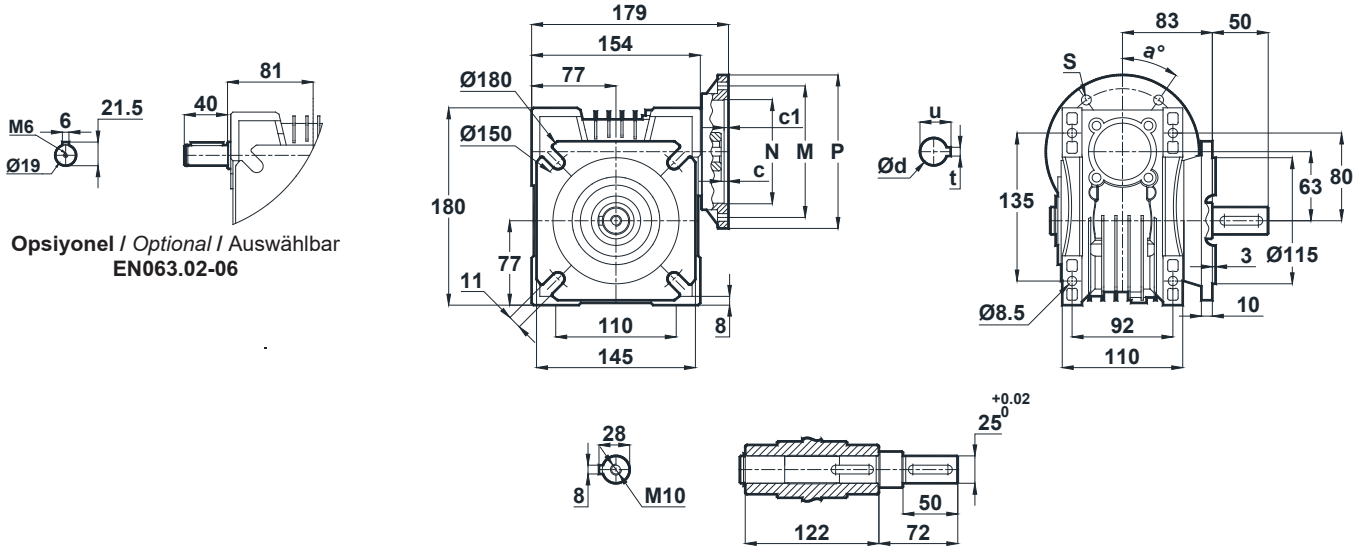

Opsiyonel / Optional / Auswählbar  
EN063.02-06

#### EN063.03

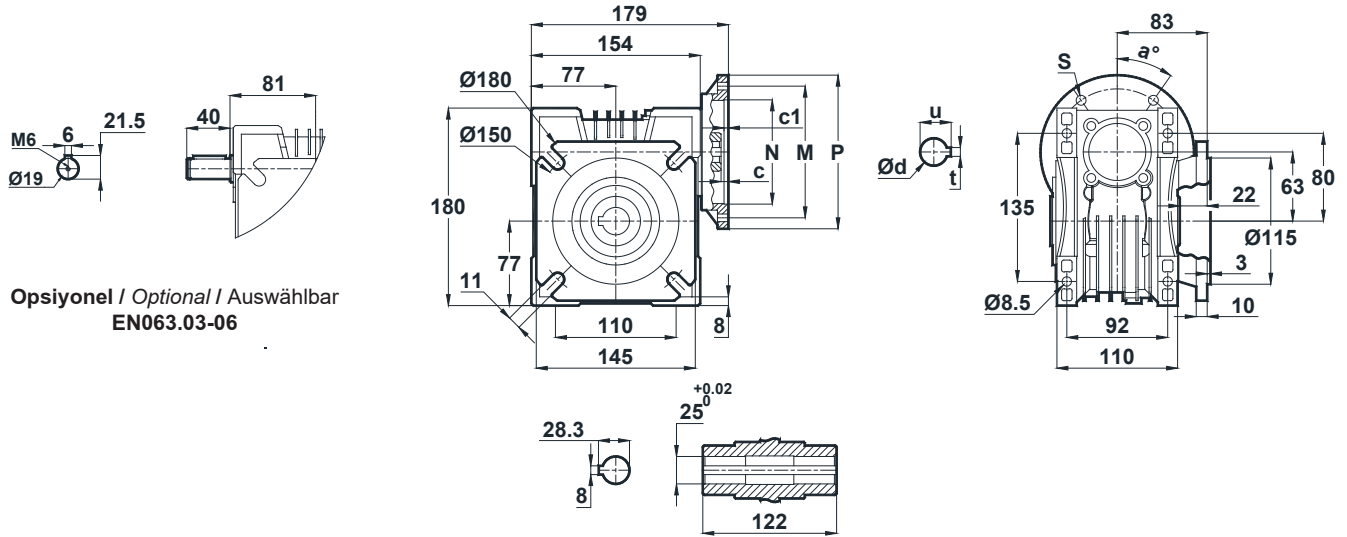

Opsiyonel / Optional / Auswählbar  
EN063.03-06

EN075	c	c1	N	M	P	d	u	t	a	s
71/B14	5,7	3	70	85	105	14	16,3	5	45°	7
80/B14	5,7	4	80	100	120	19	21,8	6	15°	7
90/B14	5,7	4,5	95	115	140	24	27,3	8	15°	9
71/B5	5,7	4,5	110	130	160	14	16,3	5	15°	10
80/B5	5,7	4,5	130	165	200	19	21,8	6	15°	12
90/B5	5,7	4,5	130	165	200	24	27,3	8	15°	12



# Ölçü Sayfaları

## Dimension Pages

### Abmessungsseiten



-Mil ucu çekirme deliği DIN 332 sayfa 2 / Tapped center hole to DIN 332, sheet 2 / Zentrierung mit Gewinde DIN 332, Blatt 2

#### EN063.04

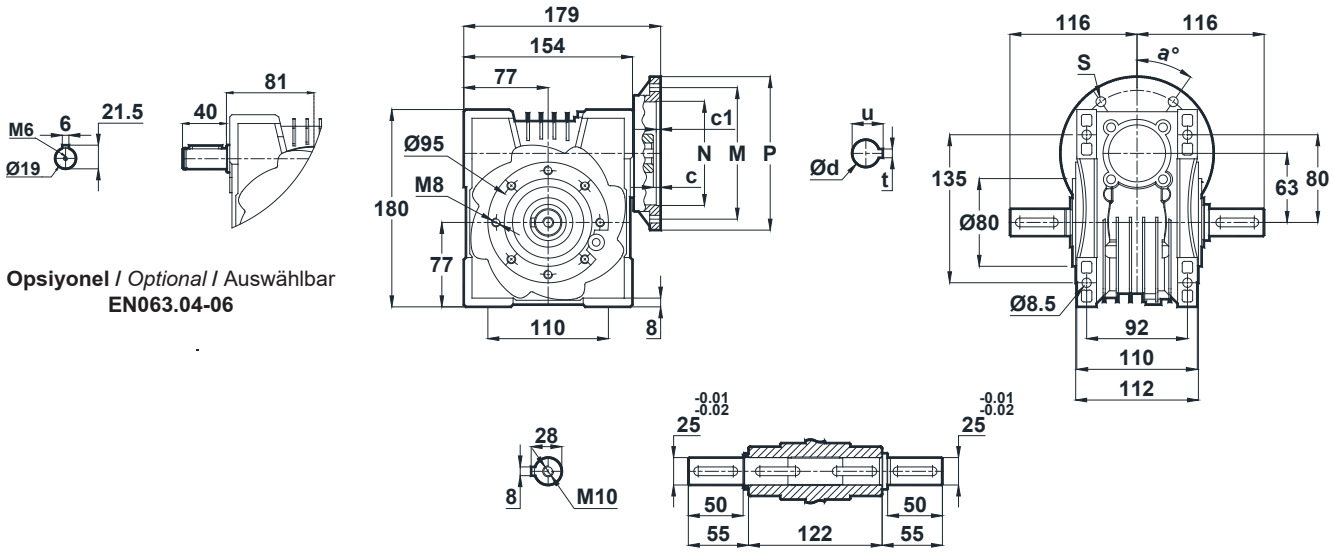

Opsiyonel / Optional / Auswählbar  
EN063.04-06

#### EN063.05

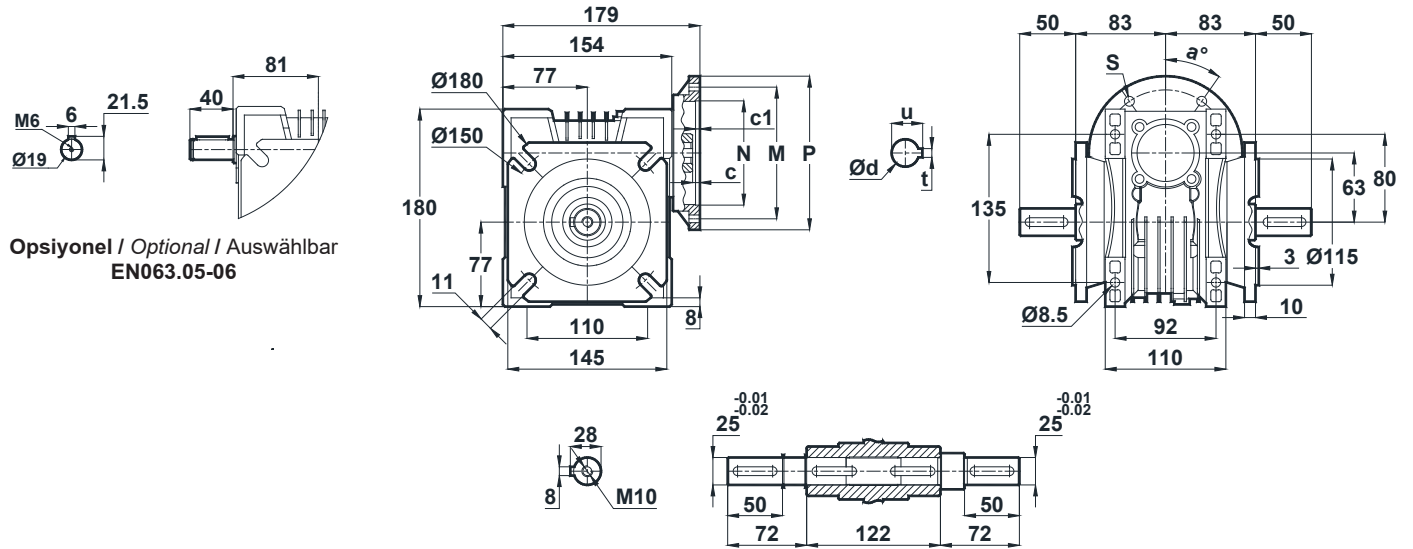

Opsiyonel / Optional / Auswählbar  
EN063.05-06

EN075	c	c1	N	M	P	d	u	t	a	s
71/B14	5,7	3	70	85	105	14	16,3	5	45°	7
80/B14	5,7	4	80	100	120	19	21,8	6	15°	7
90/B14	5,7	4,5	95	115	140	24	27,3	8	15°	9
71/B5	5,7	4,5	110	130	160	14	16,3	5	15°	10
80/B5	5,7	4,5	130	165	200	19	21,8	6	15°	12
90/B5	5,7	4,5	130	165	200	24	27,3	8	15°	12



# Ölçü Sayfaları

## Dimension Pages

### Abmessungsseiten



-Mil ucu çekirme deliği DIN 332 sayfa 2 / Tapped center hole to DIN 332, sheet 2 / Zentrierung mit Gewinde DIN 332, Blatt 2

EN063.08

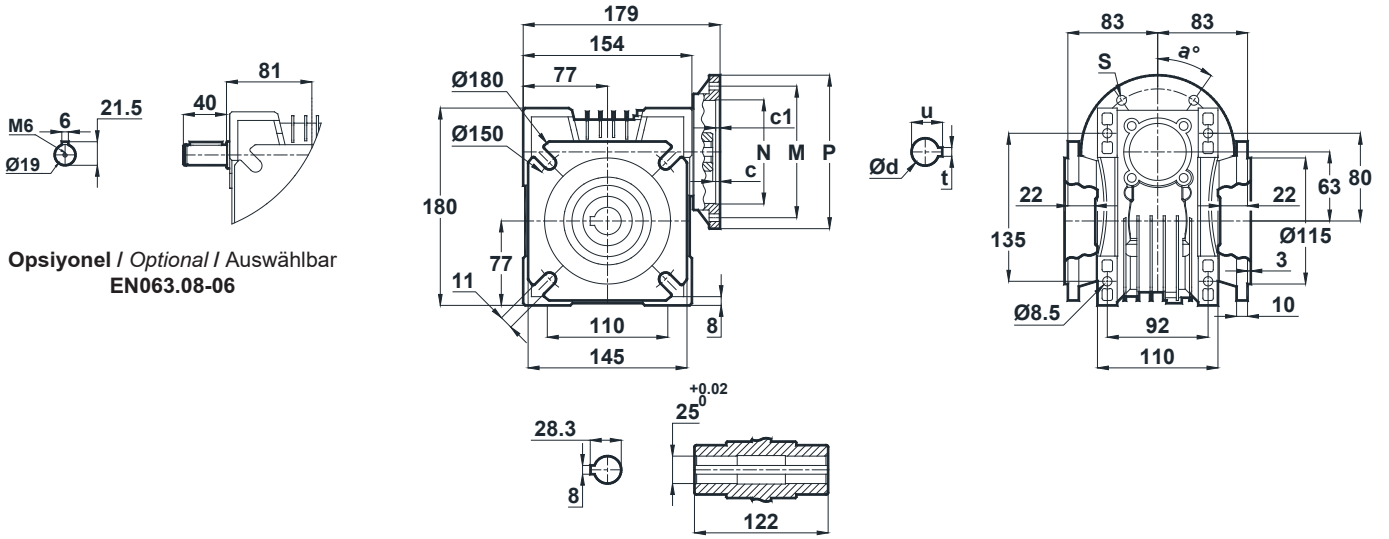

Opsiyonel / Optional / Auswählbar  
EN063.08-06

EN075	c	c1	N	M	P	d	u	t	a	s
71/B14	5,7	3	70	85	105	14	16,3	5	45°	7
80/B14	5,7	4	80	100	120	19	21,8	6	15°	7
90/B14	5,7	4,5	95	115	140	24	27,3	8	15°	9
71/B5	5,7	4,5	110	130	160	14	16,3	5	15°	10
80/B5	5,7	4,5	130	165	200	19	21,8	6	15°	12
90/B5	5,7	4,5	130	165	200	24	27,3	8	15°	12



# Ölçü Sayfaları Dimension Pages Abmessungsseiten



-Mil ucu çekirme deliği DIN 332 sayfa 2 / Tapped center hole to DIN 332, sheet 2 / Zentrierung mit Gewinde DIN 332, Blatt 2

## EN075.00

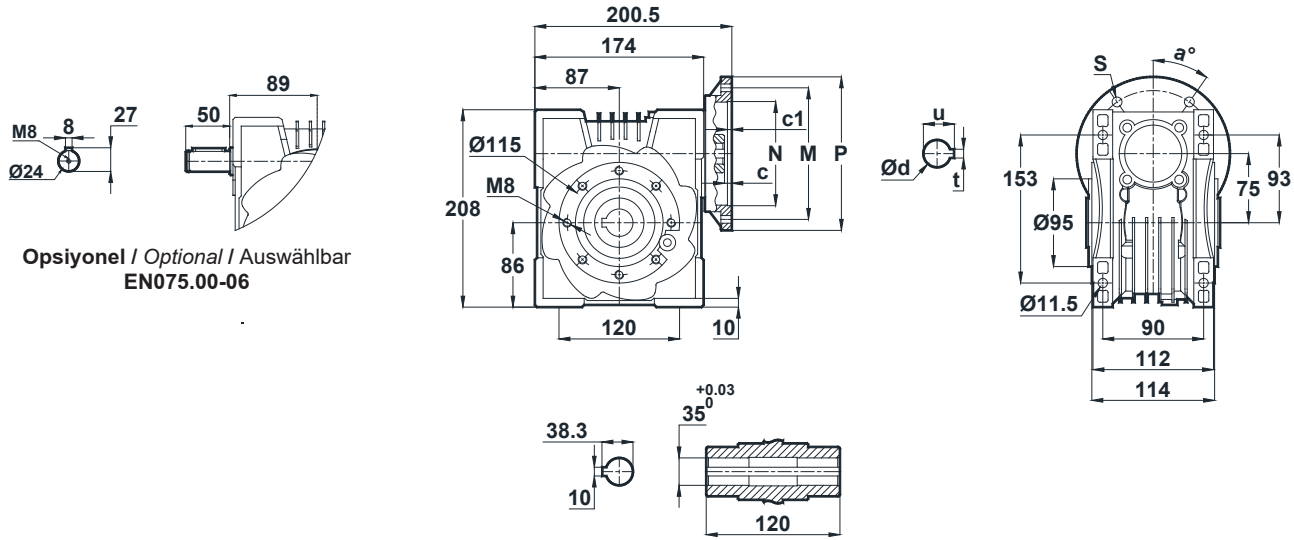

## EN075.01

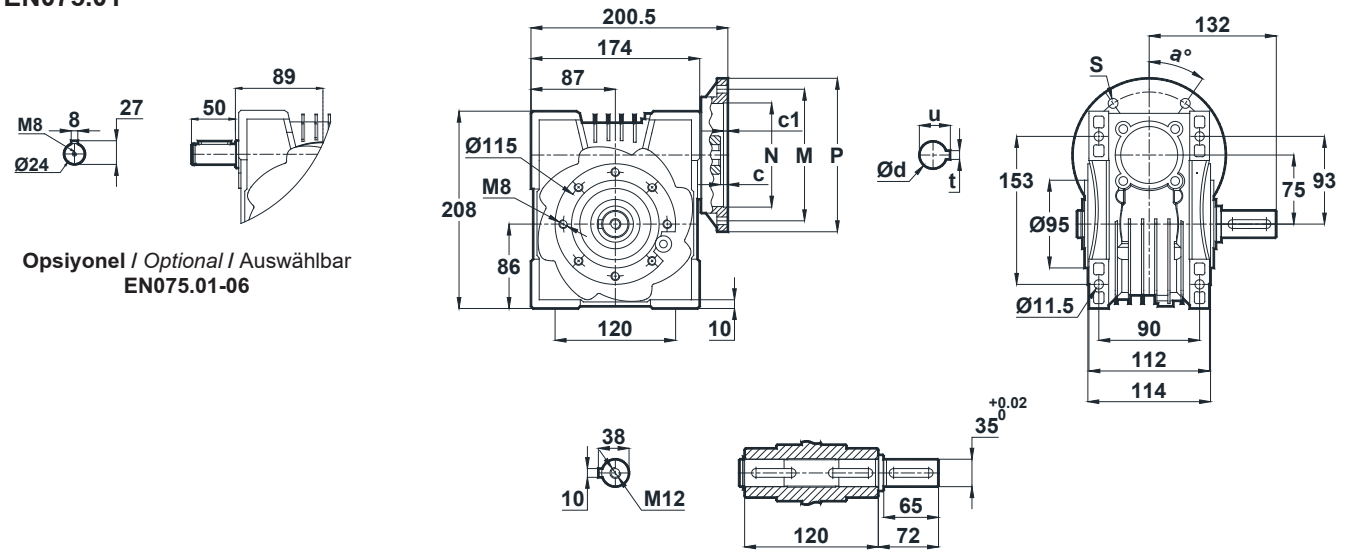

EN075	c	c1	N	M	P	d	u	t	a	s
80/B14	10,5	5	80	100	120	19	21,8	6	30°	7
90/B14	10,5	5	95	115	140	24	27,3	8	15°	9
100-112/B14	10,5	4	110	130	160	28	31,3	8	15°	9
80/B5	10,5	4,5	130	165	200	19	21,8	6	15°	12
90/B5	10,5	4,5	130	165	200	24	27,3	8	15°	12
100-112/B5	10,5	4,5	180	215	250	28	31,3	8	15°	13



# Ölçü Sayfaları Dimension Pages Abmessungsseiten



-Mil ucu çekirme deliği DIN 332 sayfa 2 / Tapped center hole to DIN 332, sheet 2 / Zentrierung mit Gewinde DIN 332, Blatt 2

## EN075.02

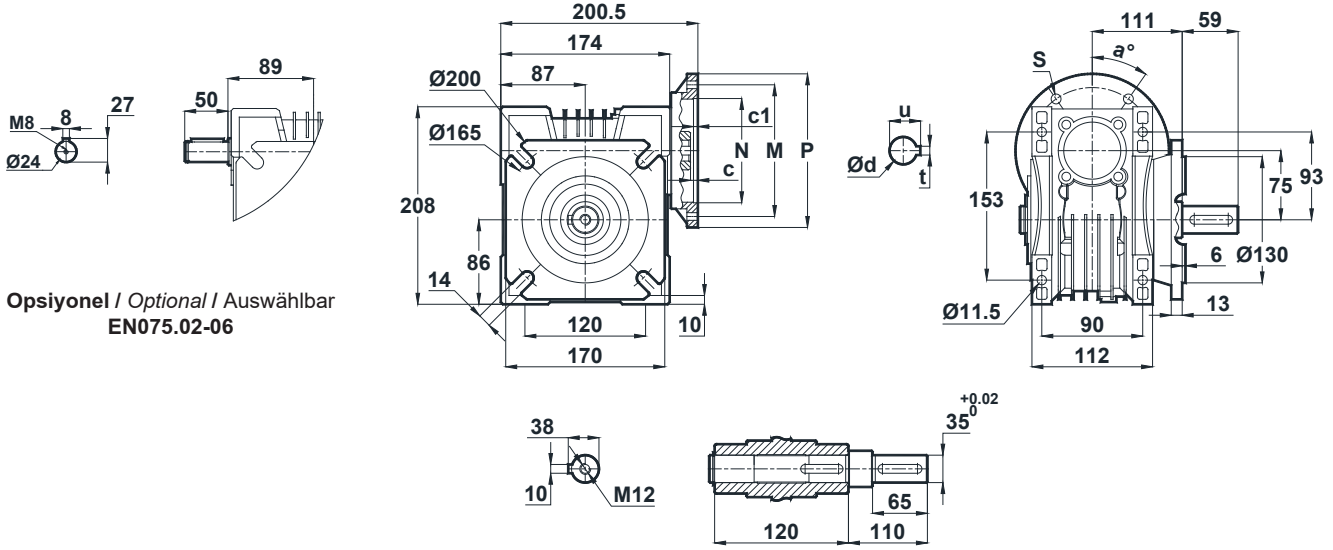

Opsiyonel / Optional / Auswählbar  
EN075.02-06

## EN075.03

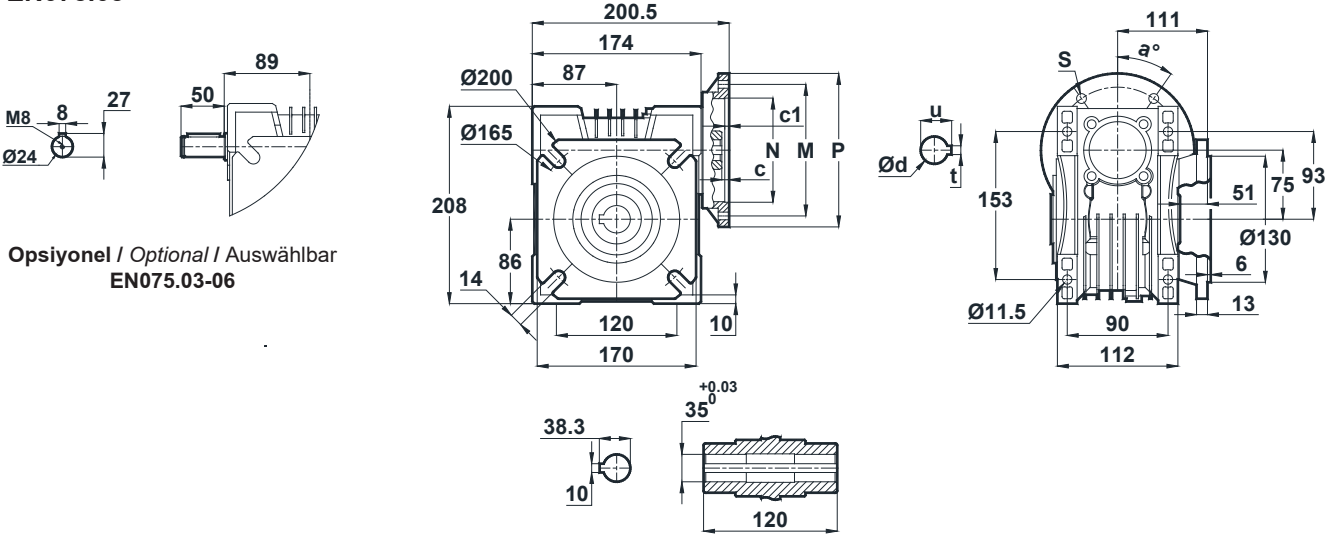

Opsiyonel / Optional / Auswählbar  
EN075.03-06

EN075	c	c1	N	M	P	d	u	t	a	s
80/B14	10,5	5	80	100	120	19	21,8	6	30°	7
90/B14	10,5	5	95	115	140	24	27,3	8	15°	9
100-112/B14	10,5	4	110	130	160	28	31,3	8	15°	9
80/B5	10,5	4,5	130	165	200	19	21,8	6	15°	12
90/B5	10,5	4,5	130	165	200	24	27,3	8	15°	12
100-112/B5	10,5	4,5	180	215	250	28	31,3	8	15°	13



# Ölçü Sayfaları

## Dimension Pages

### Abmessungsseiten



-Mil ucu çekirme deliği DIN 332 sayfa 2 / Tapped center hole to DIN 332, sheet 2 / Zentrierung mit Gewinde DIN 332, Blatt 2

#### EN075.04

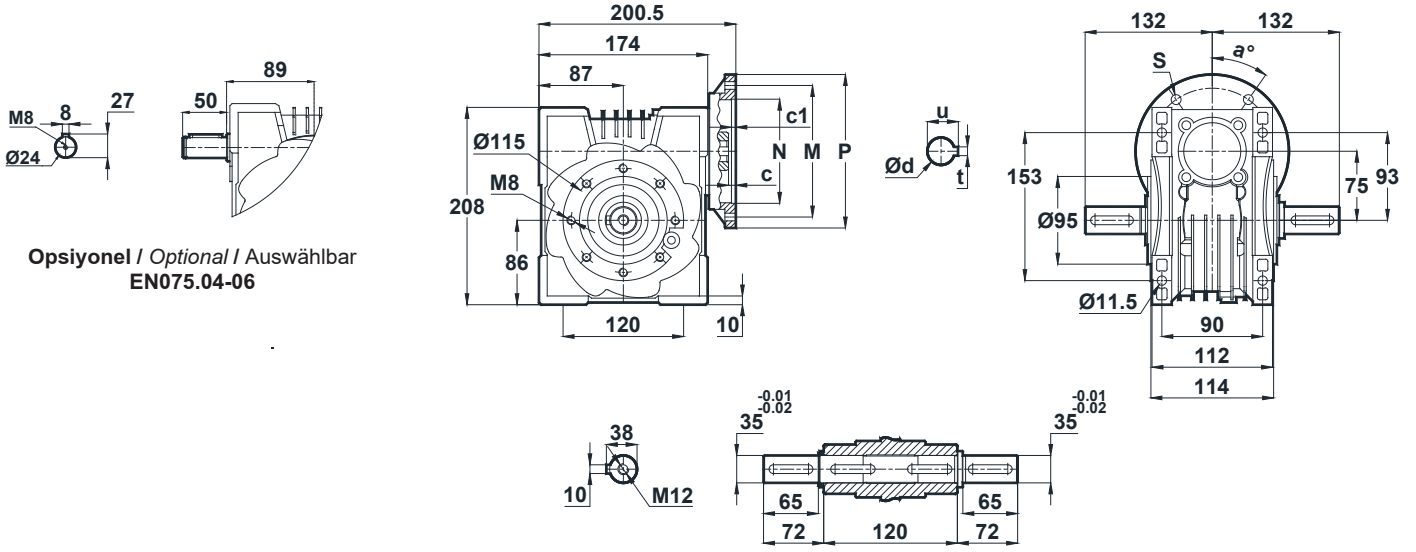

Opsiyonel / Optional / Auswählbar  
EN075.04-06

#### EN075.05

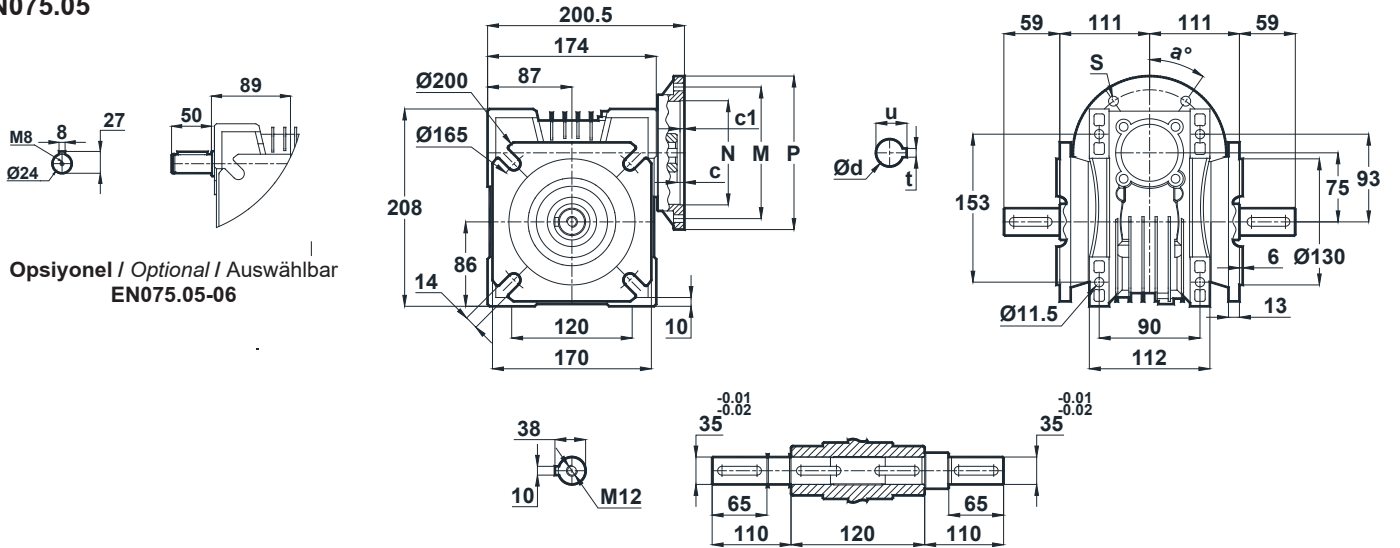

Opsiyonel / Optional / Auswählbar  
EN075.05-06

EN075	c	c1	N	M	P	d	u	t	a	s
80/B14	10,5	5	80	100	120	19	21,8	6	30°	7
90/B14	10,5	5	95	115	140	24	27,3	8	15°	9
100-112/B14	10,5	4	110	130	160	28	31,3	8	15°	9
80/B5	10,5	4,5	130	165	200	19	21,8	6	15°	12
90/B5	10,5	4,5	130	165	200	24	27,3	8	15°	12
100-112/B5	10,5	4,5	180	215	250	28	31,3	8	15°	13



# Ölçü Sayfaları

## Dimension Pages

### Abmessungsseiten



-Mil ucu çekirme deliği DIN 332 sayfa 2 / Tapped center hole to DIN 332, sheet 2 / Zentrierung mit Gewinde DIN 332, Blatt 2

EN075.08

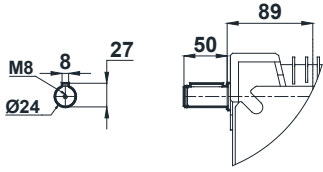

Opsiyonel / Optional / Auswählbar  
EN075.08-06

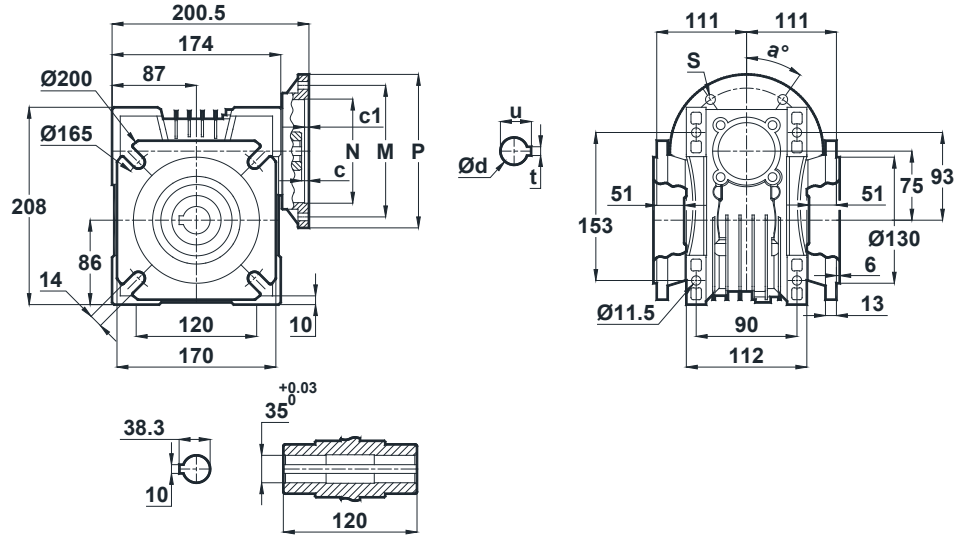

EN075	c	c1	N	M	P	d	u	t	a	s
80/B14	10,5	5	80	100	120	19	21,8	6	30°	7
90/B14	10,5	5	95	115	140	24	27,3	8	15°	9
100-112/B14	10,5	4	110	130	160	28	31,3	8	15°	9
80/B5	10,5	4,5	130	165	200	19	21,8	6	15°	12
90/B5	10,5	4,5	130	165	200	24	27,3	8	15°	12
100-112/B5	10,5	4,5	180	215	250	28	31,3	8	15°	13





# Ölçü Sayfaları

## Dimension Pages

### Abmessungsseiten



-Mil ucu çekirme deliği DIN 332 sayfa 2 / Tapped center hole to DIN 332, sheet 2 / Zentrierung mit Gewinde DIN 332, Blatt 2

#### EN080.02

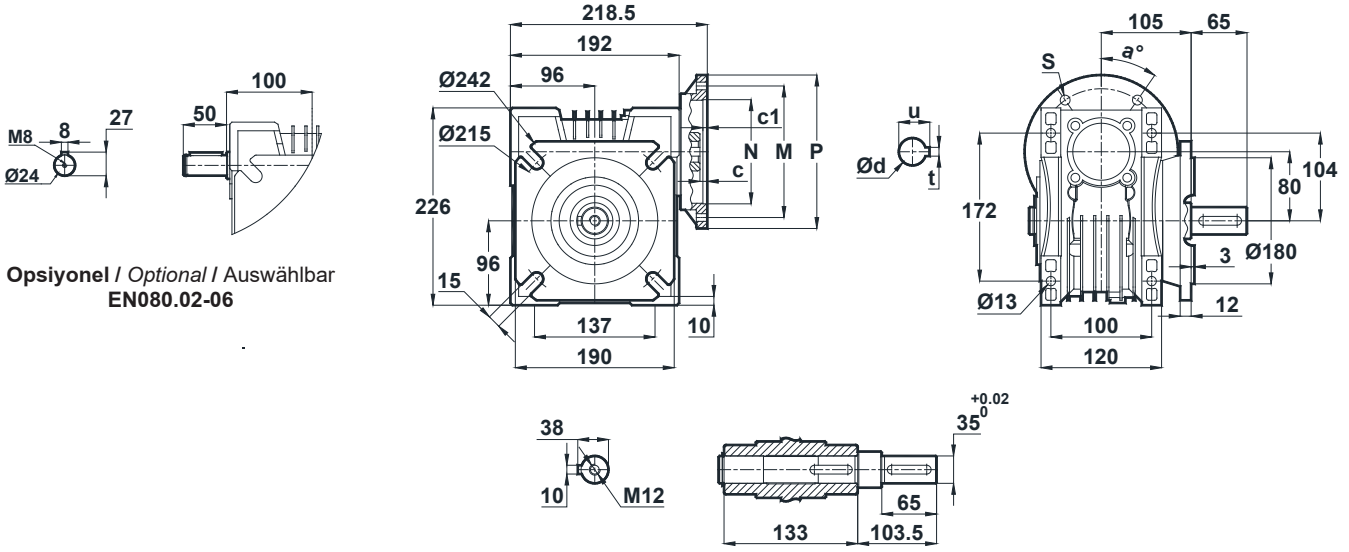

Opsiyonel / Optional / Auswählbar  
EN080.02-06

#### EN080.03

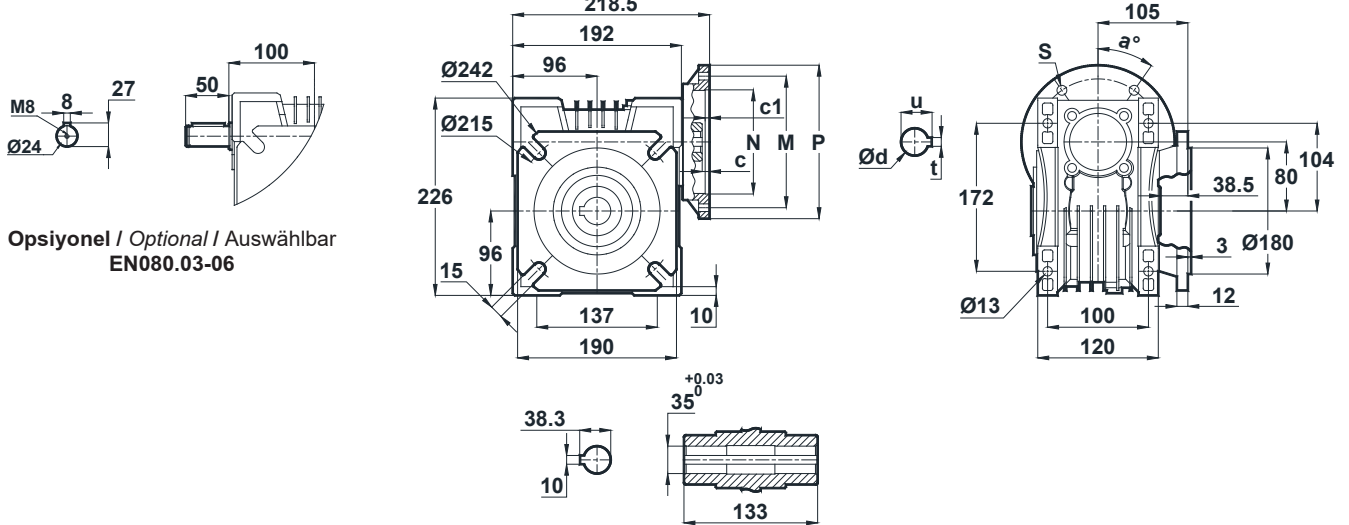

Opsiyonel / Optional / Auswählbar  
EN080.03-06

EN080	c	c1	N	M	P	d	u	t	a	s
80/B14	5,5	5	80	100	120	19	21,8	6	30°	7
90/B14	5,5	5	95	115	140	24	27,3	8	15°	9
100-112/B14	5,5	5	110	130	160	28	31,3	8	45°	9
80/B5	5,5	4,5	130	165	200	19	21,8	6	15°	13
90/B5	5,5	4,5	130	165	200	24	27,3	8	15°	13
100-112/B5	5,5	4,5	180	215	250	28	31,3	8	45°	13







# Ölçü Sayfaları

## Dimension Pages

### Abmessungsseiten



-Mil ucu çekirme deliği DIN 332 sayfa 2 / Tapped center hole to DIN 332, sheet 2 / Zentrierung mit Gewinde DIN 332, Blatt 2

#### EN100.00

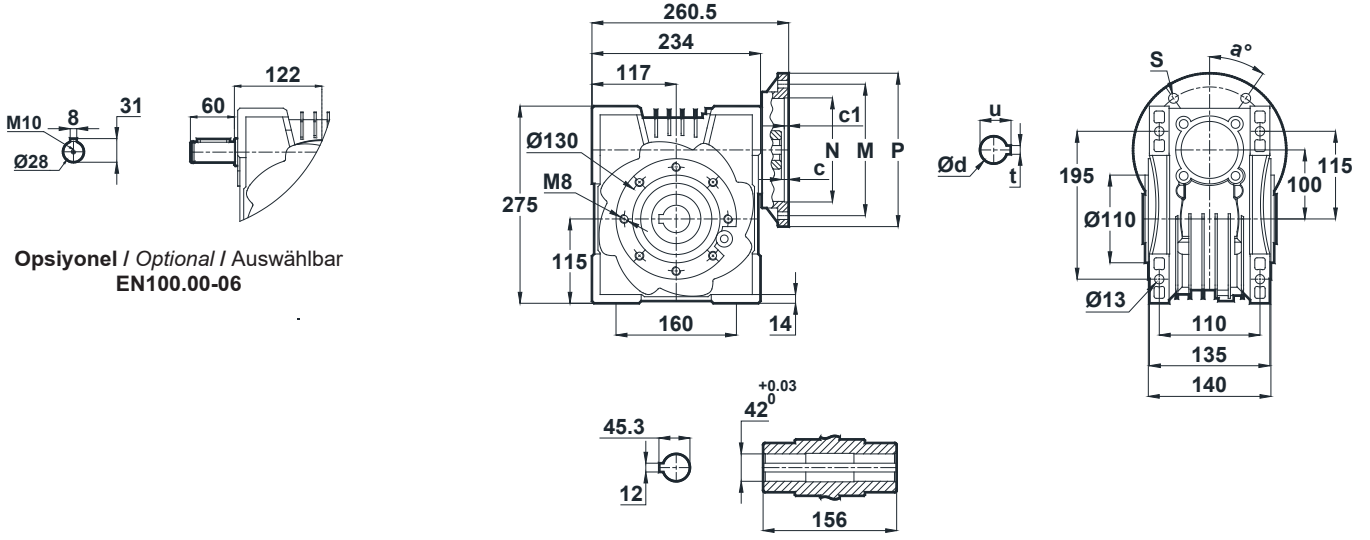

Opsiyonel / Optional / Auswählbar  
EN100.00-06

#### EN100.01

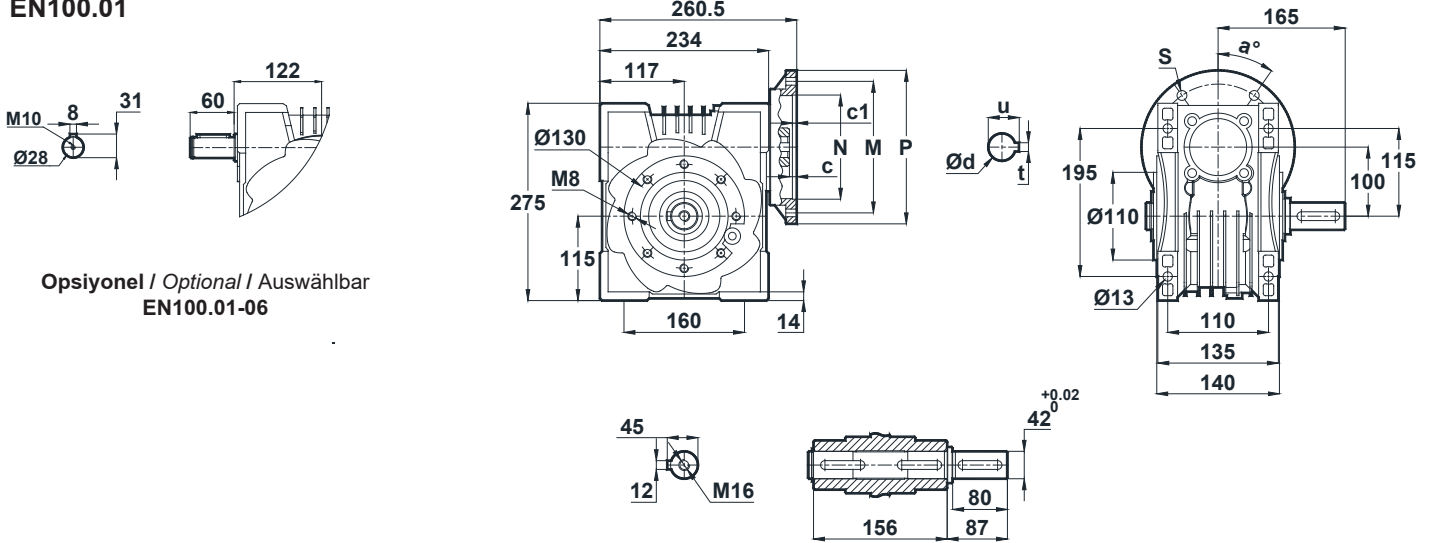

Opsiyonel / Optional / Auswählbar  
EN100.01-06

EN100	c	c1	N	M	P	d	u	t	a	s
80/B14	5,5	5	80	100	120	19	21,8	6	30°	7
90/B14	5,5	5	95	115	140	24	27,3	8	45°	9
100-112/B14	5,5	4	110	130	160	28	31,3	8	45°	9
80/B5	5,5	4,5	130	165	200	19	21,8	6	45°	12
90/B5	5,5	4,5	130	165	200	24	27,3	8	45°	12
100-112/B5	5,5	4,5	180	215	250	28	31,3	8	45°	13



# Ölçü Sayfaları

## Dimension Pages

### Abmessungsseiten



-Mil ucu çekirme deliği DIN 332 sayfa 2 / Tapped center hole to DIN 332, sheet 2 / Zentrierung mit Gewinde DIN 332, Blatt 2

#### EN100.02

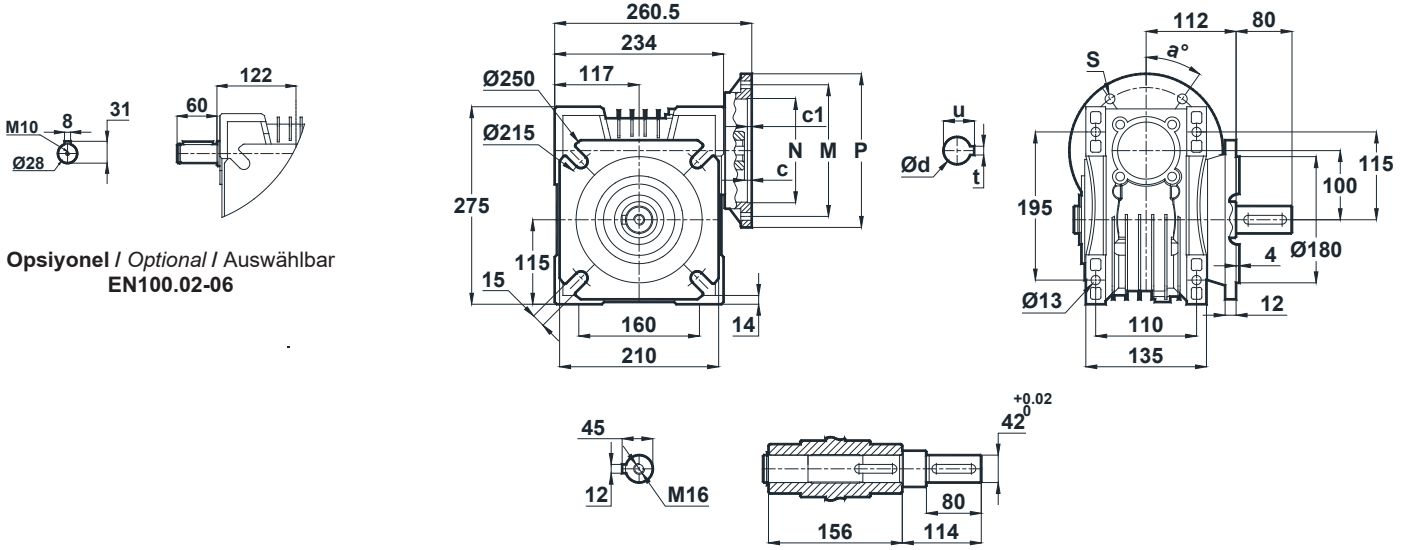

Opsiyonel / Optional / Auswählbar  
EN100.02-06

#### EN100.03

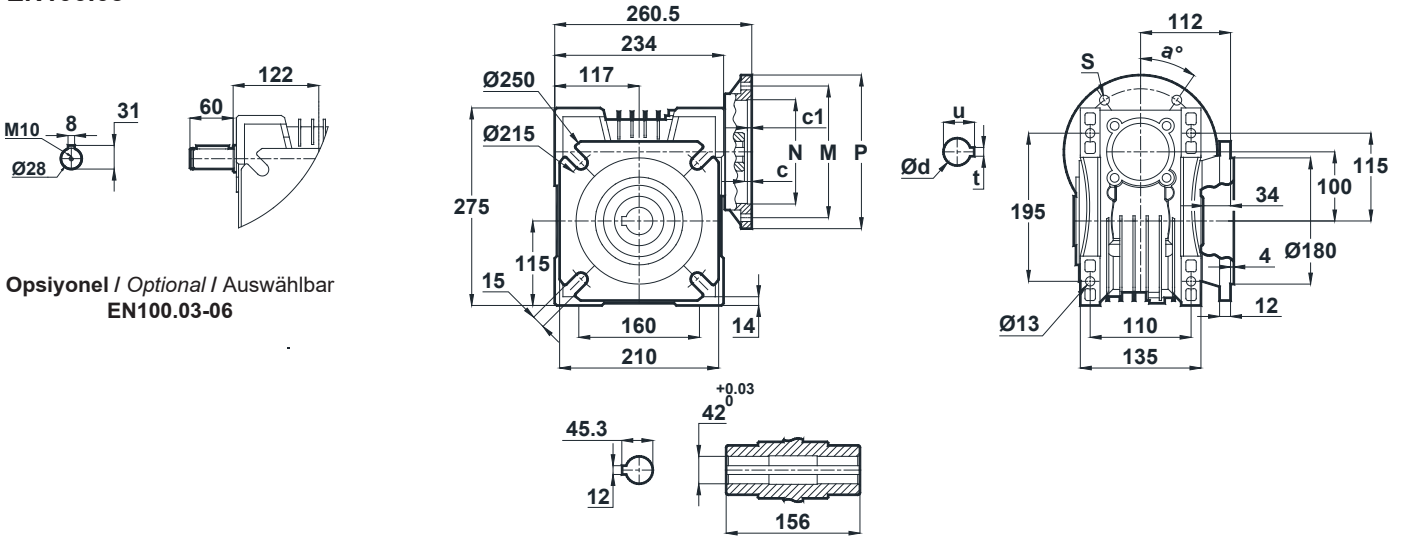

Opsiyonel / Optional / Auswählbar  
EN100.03-06

EN100	c	c1	N	M	P	d	u	t	a	s
80/B14	5,5	5	80	100	120	19	21,8	6	30°	7
90/B14	5,5	5	95	115	140	24	27,3	8	45°	9
100-112/B14	5,5	4	110	130	160	28	31,3	8	45°	9
80/B5	5,5	4,5	130	165	200	19	21,8	6	45°	12
90/B5	5,5	4,5	130	165	200	24	27,3	8	45°	12
100-112/B5	5,5	4,5	180	215	250	28	31,3	8	45°	13







# Ölçü Sayfaları

## Dimension Pages

### Abmessungsseiten



-Mil ucu çekirme deliği DIN 332 sayfa 2 / Tapped center hole to DIN 332, sheet 2 / Zentrierung mit Gewinde DIN 332, Blatt 2

#### EN125.00

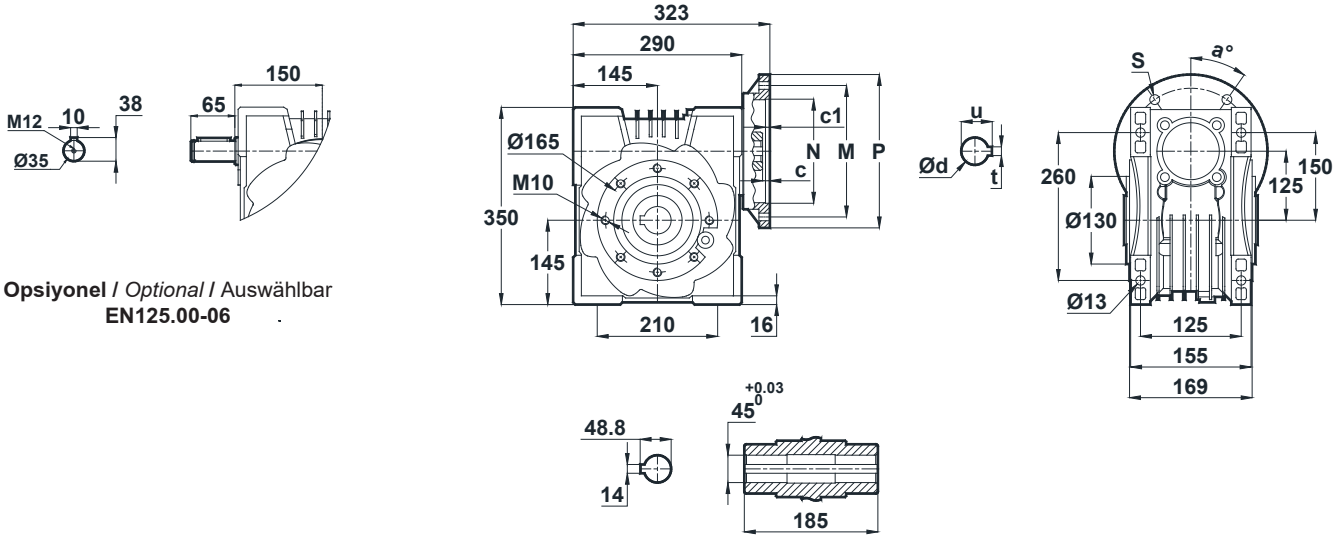

#### EN125.01

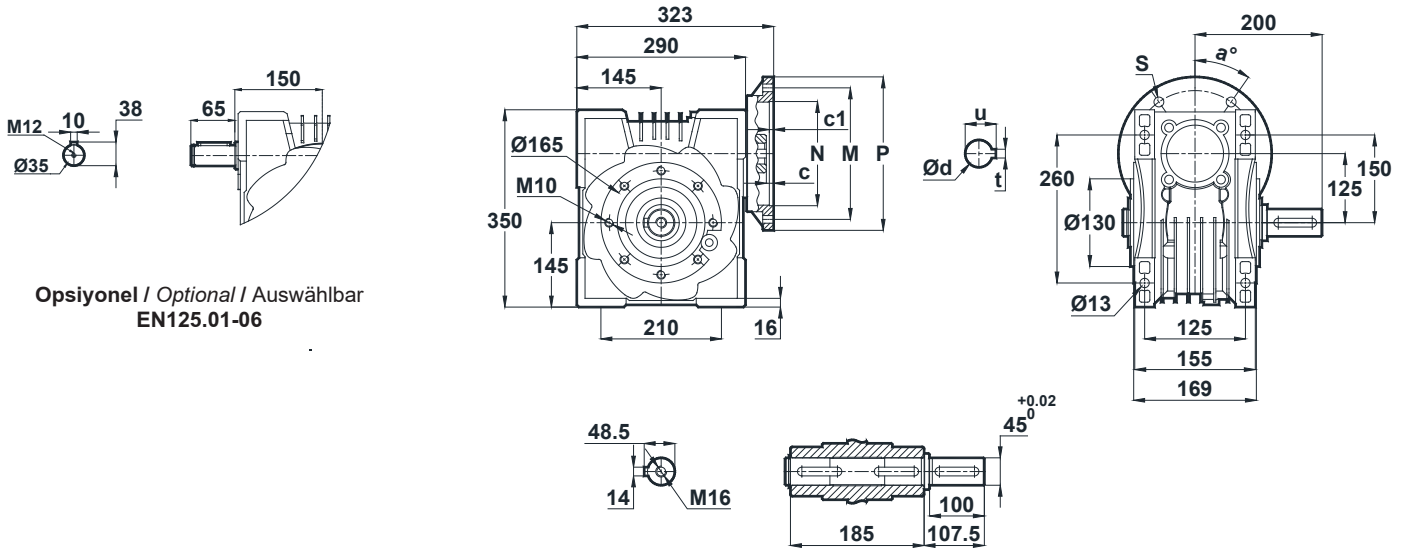

EN125	c	c1	N	M	P	d	u	t	a	s
100-112/B14	12,8	4	110	130	160	28	31,3	8	45°	9
132/B14	12,8	4	130	165	200	38	41,3	10	15°	11
90/B5	12,8	4	130	165	200	24	27,3	8	15°	11
100-112/B5	15,8	4	180	215	250	28	31,3	8	45°	15
132/B5	15,8	4	230	265	300	38	41,3	10	15°	15



# Ölçü Sayfaları

## Dimension Pages

### Abmessungsseiten



-Mil ucu çekirme deliği DIN 332 sayfa 2 / Tapped center hole to DIN 332, sheet 2 / Zentrierung mit Gewinde DIN 332, Blatt 2

#### EN125.02

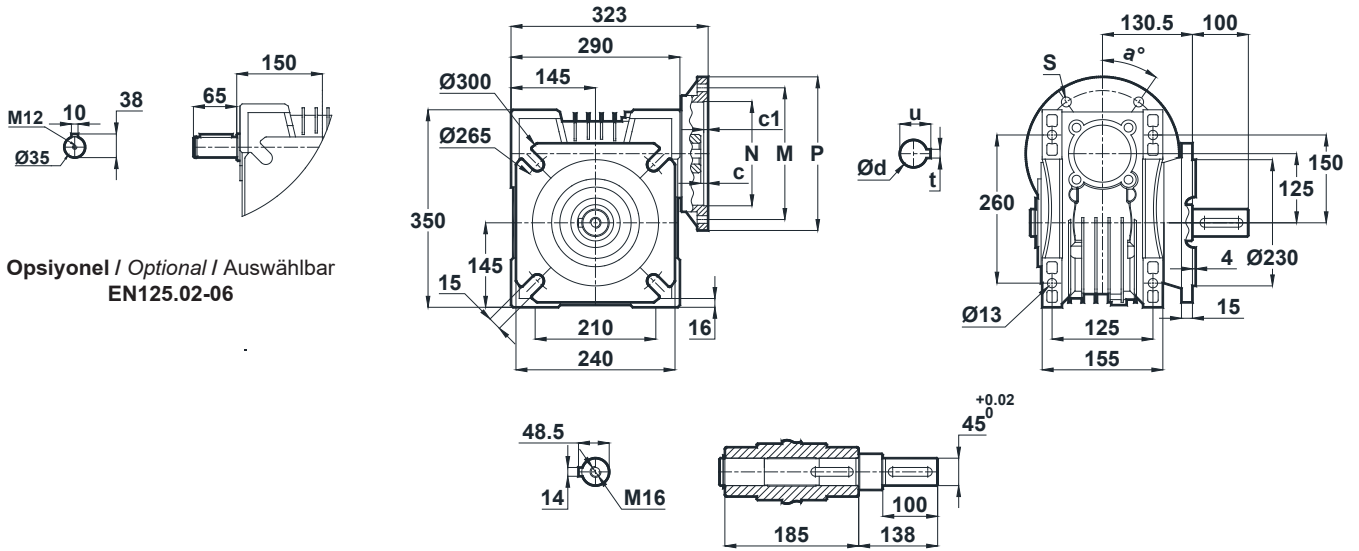

Opsiyonel / Optional / Auswählbar  
EN125.02-06

#### EN125.03

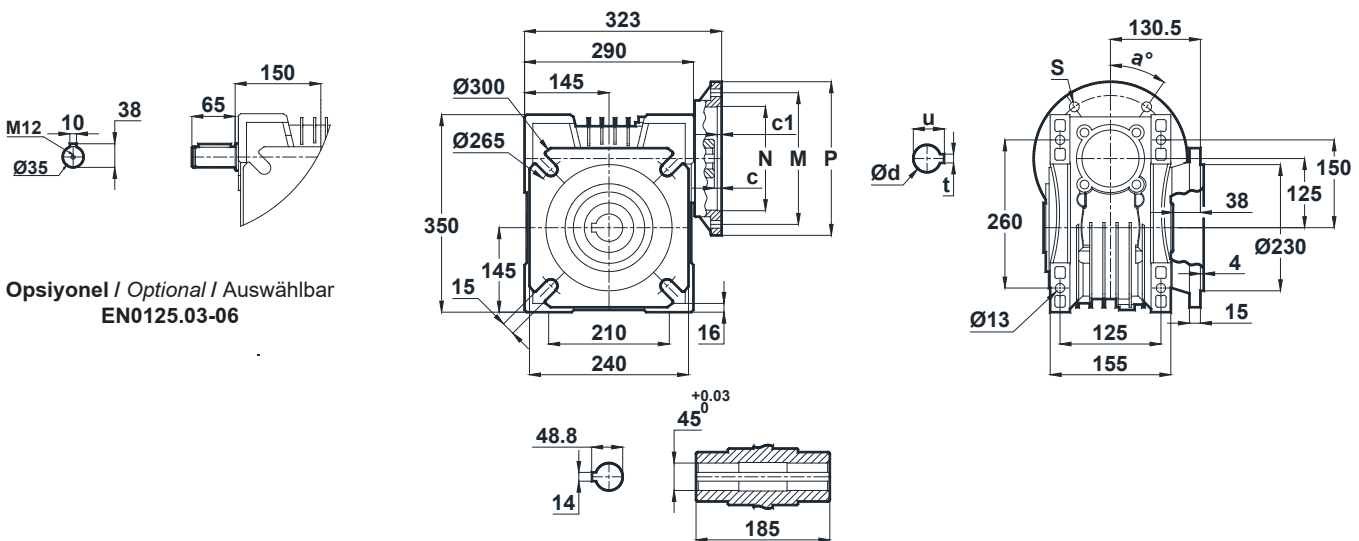

Opsiyonel / Optional / Auswählbar  
EN0125.03-06

EN125	c	c1	N	M	P	d	u	t	a	s
100-112/B14	12,8	4	110	130	160	28	31,3	8	45°	9
132/B14	12,8	4	130	165	200	38	41,3	10	15°	11
90/B5	12,8	4	130	165	200	24	27,3	8	15°	11
100-112/B5	15,8	4	180	215	250	28	31,3	8	45°	15
132/B5	15,8	4	230	265	300	38	41,3	10	15°	15



# Ölçü Sayfaları Dimension Pages Abmessungsseiten

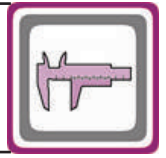

-Mil ucu çekirme deliği DIN 332 sayfa 2 / Tapped center hole to DIN 332, sheet 2 / Zentrierung mit Gewinde DIN 332, Blatt 2

## EN125.04

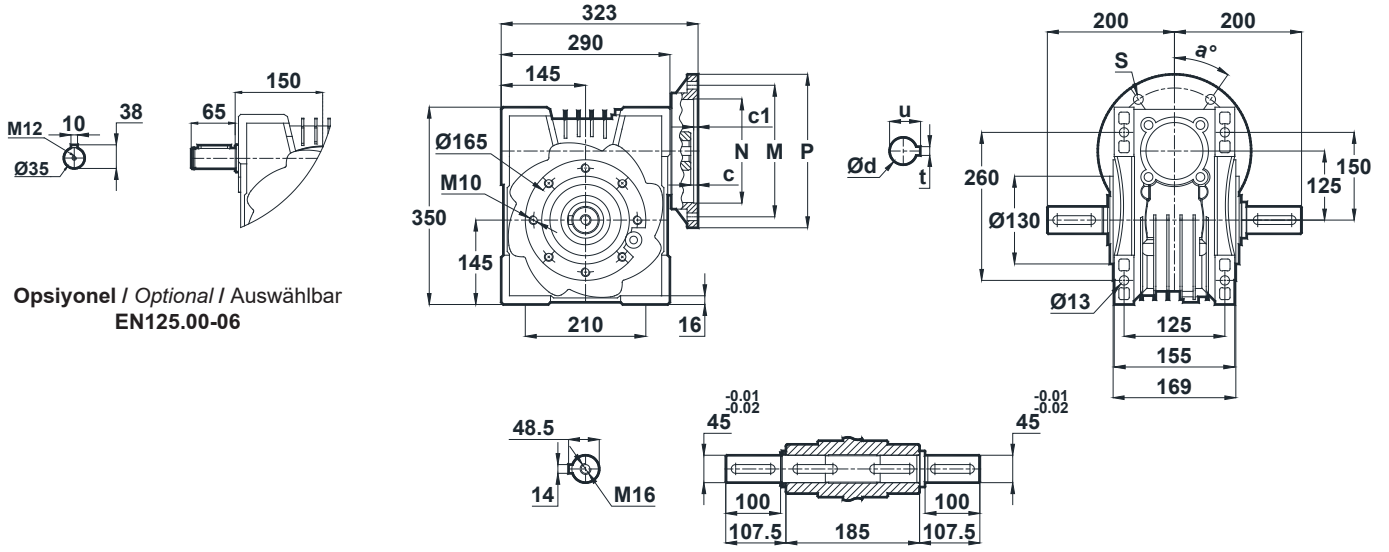

Opsiyonel / Optional / Auswählbar  
EN125.00-06

## EN125.05

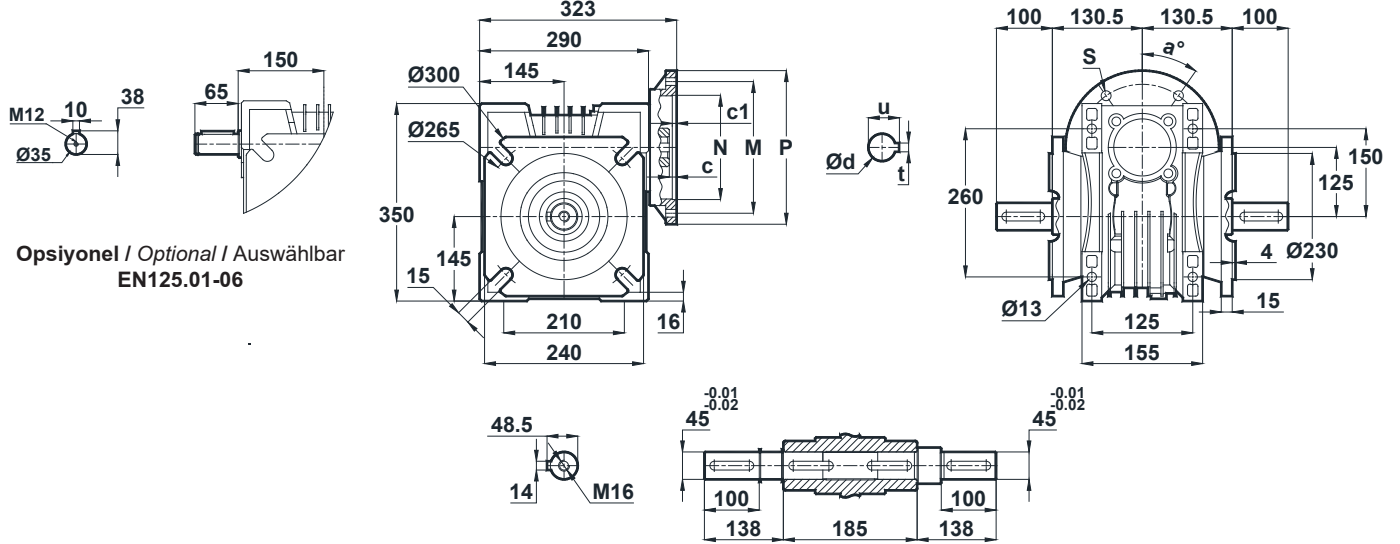

Opsiyonel / Optional / Auswählbar  
EN125.01-06

EN125	c	c1	N	M	P	d	u	t	a	s
100-112/B14	12,8	4	110	130	160	28	31,3	8	45°	9
132/B14	12,8	4	130	165	200	38	41,3	10	15°	11
90/B5	12,8	4	130	165	200	24	27,3	8	15°	11
100-112/B5	15,8	4	180	215	250	28	31,3	8	45°	15
132/B5	15,8	4	230	265	300	38	41,3	10	15°	15



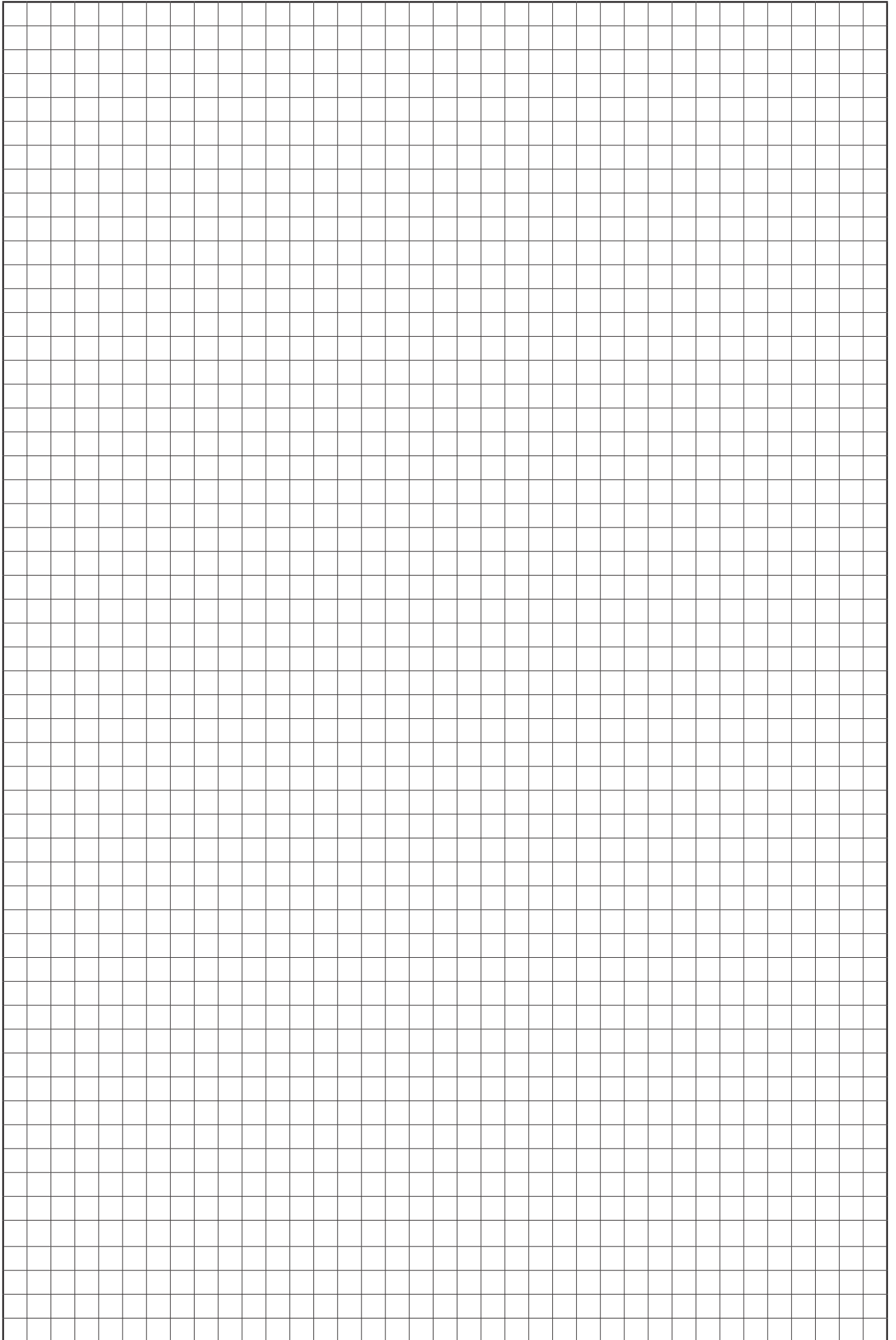

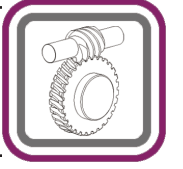

# Güç ve Devir Tabloları

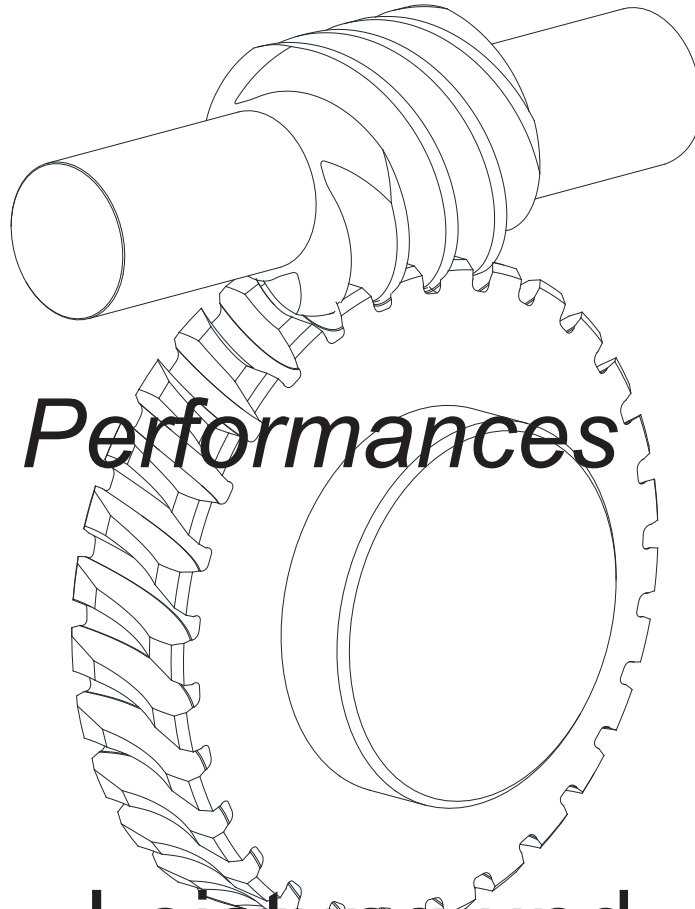

*Performances*

**Leistung und  
Drehzahlübersicht**

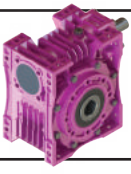

# E Serisi Motorsuz Güç Devir Sayfaları

## E Series Gear Units Performance Tables

### E Serien Getriebe Leistung und Drehzahlübersicht

300

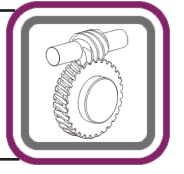

Tipi Type Typ	Anma Momenti Nominal Torques Nenn-drehmomente	Çevrim Oranı Ratio Übersetzung	Çıkış Devri Output speeds Abtriebs-drehzahl	Giriş Devri Input Speeds Antriebs-drehzahl	Güç Pe/Pt [kW] (Servis Faktörü fs=1,0 için) Pe=Mekanik Güç / Pt=Termik Güç Power Pe/Pt [kW] (For Service Factor fs=1,0) Pe=Mechanical Power / Pt=Thermal Power Leistung Pe/Pt [kW] (Bei Betriebsfaktor fs=1,0) Pe=Mechanische Leistung / Pt=Thermische Leistung				Güv. Rad.Yük Çıkış Per.O.Loads (Output) Zul.Querkräfte (Abtrieb)	Güv.Rad.Yük Giriş Per.O.Loads (Input) Zul.Querkräfte (Antrieb)	Ağırlık Weight Gewicht	Ölçü Sayfası Dim. Page Maße Seite	Fiyat Kodu Price Ref. Preis Num.	
	Ma [Nm]	i	n2 [rpm]	n1 [rpm]	Pe [kW]	Pt [kW]	γ	η	Fqam [N]	Fqem [N]	[kg]			
	ET030	25	5.25	57	300	0.18	0.51	26°33'	0.83	1109	205	1,2	166	ET01
		22	7.25	41		0.12	0.42	19°26'	0.79	1208	205			
21		10.5	29		0.09	0.34	14°02'	0.74	1277	205				
22		14.5	21		0.07	0.27	10°00'	0.68	1475	205				
21		17	18		0.06	0.24	8°07'	0.63	1561	205				
20		21.0	14		0.05	0.22	7°07'	0.60	1732	205				
19		25.0	12		0.04	0.19	5°35'	0.54	1830	205				
19		29.0	10		0.04	0.18	5°02'	0.52	1830	205				
17		34.0	8.8		0.03	0.16	4°05'	0.46	1830	205				
14		42.0	7.1		0.02	0.15	3°22'	0.42	1830	205				
11		50.0	6.0		0.02	0.15	3°12'	0.41	1830	205				
6		60.0	5.0		0.01	0.12	2°45'	0.28	1830	205				
5	80	3,8		0.01	0,11	2°07'	0,27	1830	205					
ET040	56	8.0	38	300	0.27	0.86	26°33'	0.83	2325	360	2,4	170	ET02	
	53	10.5	29		0.20	0.72	19°26'	0.79	2550	360				
	56	12	25		0.20	0.59	14°22'	0.75	2610	360				
	51	16	19		0.14	0.57	14°02'	0.74	3001	360				
	48	21	14		0.11	0.47	10°00'	0.68	3149	360				
	42	25	12		0.09	0.38	8°07'	0.61	3261	360				
	39	32	8,8		0.07	0.31	7°07'	0.53	3400	360				
	32	42	7.1		0.05	0.28	5°02'	0.47	3400	360				
	33	50	6.0		0.05	0.26	4°05'	0.42	3400	360				
	29	62	4.8		0.04	0.22	3°22'	0.38	3400	360				
	23	80	3,7		0,03	0,20	2°51'	0,38	3400	360				
	22	100	3,0		0,02	0,16	2°25'	0,36	3400	360				
ET050	85	7.25	41	300	0.46	1.14	20°40'	0.80	3535	500	4,1	174	ET03	
	80	9.5	32		0.33	1.09	19°39'	0.79	3621	500				
	84	12	25		0.30	0.85	13°14'	0.73	3920	500				
	85	14.5	21		0.26	0.75	10°41'	0.70	4298	500				
	78	19	16		0.19	0.72	10°07'	0.68	4364	500				
	80	25	12		0.15	0.65	8°44'	0.65	4800	500				
	74	29	10		0.15	0.49	5°06'	0.54	4800	500				
	66	38	7.9		0.10	0.48	5°23'	0.52	4800	500				
	60	50	6.0		0.08	0.44	4°23'	0.48	4800	500				
	54	62	4.8		0.07	0.38	3°11'	0.41	4800	500				
	46	83	3,7		0.04	0.39	3°22'	0.42	4800	500				
	44	100	3,0		0,03	0,36	2°21'	0,38	4800	500				
ET063	164	7.25	41	300	0.86	2.07	20°36'	0.83	4398	700	6,4	178	ET04	
	144	9.75	31		0.58	1.72	20°40'	0.80	4671	700				
	134	12.75	24		0.42	1.69	19°39'	0.79	5166	700				
	166	14.5	21		0.49	1.32	10°39'	0.74	4925	700				
	142	19.5	15		0.33	1.16	10°41'	0.70	5585	700				
	130	25.5	12		0.24	1.07	10°07'	0.67	6480	700				
	149	29	10		0.28	0.84	5°22'	0.58	6196	700				
	121	39	7.7		0.18	0.75	5°23'	0.53	6200	700				
	109	51	5.8		0.13	0.73	5°06'	0.52	6200	700				
	101	61	4.9		0.13	0.59	3°16'	0.41	6200	700				
	88	82	3.6		0.08	0.58	3°11'	0.40	6200	700				
	53	100	3.0		0.05	0.52	2°12'	0.32	6200	700				



# E Serisi Motorsuz Güç Devir Sayfaları

## E Series Gear Units Performance Tables

### E Serien Getriebe Leistung und Drehzahlübersicht

300

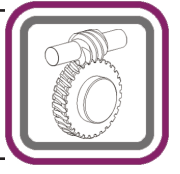

Tipi	Anma Momenti	Çevrim Oranı	Çıkış Devri	Giriş Devri	Güç Pe/Pt [kW] (Servis Faktörü fs=1,0 için) Pe=Mekanik Güç / Pt=Termik Güç				Güv. Rad.Yük Çıkış	Güv.Rad.Yük Giriş	Ağırlık	Ölçü Sayfası	Fiyat Kodu
	Nominal Torques	Ratio	Output speeds	Input Speeds	Power Pe/Pt [kW] (For Service Factor fs=1,0) Pe=Mechanical Power / Pt=Thermal Power				Per.O.Loads (Output)	Per.O.Loads (Input)	Weight	Dim. Page	Price Ref.
	Nenn-drehmomente	Übersetzung	Abtriebs-drehzahl	Antriebs-drehzahl	Leistung Pe/Pt [kW] (Bei Betriebsfaktor fs=1,0) Pe=Mechanische Leistung / Pt=Thermische Leistung				Zul.Querkräfte (Abtrieb)	Zul.Querkräfte (Antrieb)	Gewicht	Maße Seite	Preis Num.
	Ma [Nm]	i	n2 [rpm]	n1 [rpm]	Pe [kW]	Pt [kW]	γ	η	Fqam [N]	Fqem [N]	[kg]		
ET075	247	7.5	40	300	1.23	3.10	26°17'	0.84	6135	1100	9,2	182	ET05
	254	10	30		0.97	2.74	20°20'	0.82	6167	1100			
	258	15	20		0.70	2.11	13°52'	0.77	7224	1100			
	236	20	15		0.53	1.60	11°18'	0.70	7806	1100			
	227	25	12		0.43	1.43	9°32'	0.66	7957	1100			
	240	30	10		0.40	1.33	7°3'	0.63	8404	1100			
	204	40	7.5		0.29	1.08	5°43'	0.55	8753	1100			
	188	50	6.0		0.23	0.98	4°48'	0.50	9686	1100			
	174	60	5.0		0.20	0.89	4°8'	0.45	10437	1100			
	151	80	3.8		0.15	0.82	3°15'	0.41	11852	1100			
113	100	3.0		0.10	0.75	2°40'	0.35	13256	1100				
ET080	331	7.5	40	300	1.66	3.38	21°48'	0.84	5942	1100	11	186	ET06
	306	10	30		1.16	3.17	20°36'	0.83	6027	1100			
	266	13.25	23		0.79	2.71	20°40'	0.80	6983	1100			
	339	15	20		0.95	2.21	11°18'	0.75	6572	1100			
	307	20	15		0.67	1.98	10°39'	0.72	7400	1100			
	259	26.5	11		0.44	1.72	10°41'	0.68	7400	1100			
	309	30	10		0.53	1.42	5°42'	0.61	7400	1100			
	270	40	7.5		0.37	1.31	5°22'	0.58	7400	1100			
	219	53	5.6		0.24	1.18	5°23'	0.53	7400	1100			
	174	62	4.8		0.19	1.00	3°13'	0.45	7400	1100			
	106	82	3.6		0.10	0.93	3°16'	0.41	7400	1100			
	76	110	3.0		0.06	0.91	3°11'	0.39	7400	1100			
	ET100	583	7.5	40	300	2.87	5.64	21°48'	0.85	5497			
524		10	30		1.97	5.12	21°48'	0.84	8057	1300			
480		13	23		1.42	4.63	20°36'	0.82	8200	1300			
603		15	20		1.63	3.71	11°18'	0.77	8200	1300			
533		20	15		1.11	3.40	11°18'	0.75	8200	1300			
478		26	12		0.79	3.10	10°39'	0.73	8200	1300			
550		30	10		0.91	2.28	5°42'	0.63	8200	1300			
479		40	7.5		0.62	2.12	5°42'	0.61	8200	1300			
416		52	5.7		0.44	1.96	5°22'	0.57	8200	1300			
357		63	4.7		0.37	1.62	3°21'	0.48	8200	1300			
229		82	3.6		0.19	1.54	3°13'	0.46	8200	1300			
138		107	3.0		0.10	1.40	3°16'	0.40	8200	1300			
ET125		1061	7.25	41	300	5.31	9.50	21°48'	0.87	5894	1473	62.2	194
	959	10	30		3.54	8.57	21°48'	0.85	9602	1800			
	855	13	23		2.47	7.80	21°48'	0.84	12770	1800			
	1105	14.5	21		3.04	5.96	11°18'	0.79	10713	1800			
	984	20	15		2.00	5.64	11°18'	0.77	12335	1800			
	860	26	12		1.38	5.13	11°18'	0.75	13000	1800			
	1017	29	10		1.70	3.62	5°42'	0.65	13000	1800			
	885	40	7.5		1.10	3.46	5°42'	0.63	13000	1800			
	764	52	5.7		0.75	3.33	5°42'	0.62	13000	1800			
	746	62	4.8		0.74	2.61	3°24'	0.51	13000	1800			
	470	83	3.6		0.37	2.47	3°22'	0.48	13000	1800			
	299	107	2.8		0.19	2.34	3°13'	0.46	13000	1800			

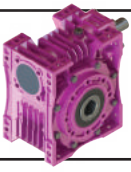

# E Serisi Motorsuz Güç Devir Sayfaları

## E Series Gear Units Performance Tables

### E Serien Getriebe Leistung und Drehzahlübersicht

450

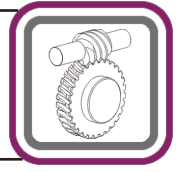

Tipi Type Typ	Anma Momenti Nominal Torques Nenn-drehmomente	Çevrim Oranı Ratio Übersetzung	Çıkış Devri Output speeds Abtriebs-drehzahl	Giriş Devri Input Speeds Antriebs-drehzahl	Güç Pe/Pt [kW] (Servis Faktörü fs=1,0 için) Pe=Mekanik Güç / Pt=Termik Güç Power Pe/Pt [kW] (For Service Factor fs=1,0) Pe=Mechanical Power / Pt=Thermal Power Leistung Pe/Pt [kW] (Bei Betriebsfaktor fs=1,0) Pe=Mechanische Leistung / Pt=Thermische Leistung				Güv. Rad.Yük Çıkış Per.O.Loads (Output) Zul.Querkräfte (Abtrieb)	Güv.Rad.Yük Giriş Per.O.Loads (Input) Zul.Querkräfte (Antrieb)	Ağırlık Weight Gewicht	Ölçü Sayfası Dim. Page Maße Seite	Fiyat Kodu Price Ref. Preis Num.	
	Ma [Nm]	i	n2 [rpm]	n1 [rpm]	Pe [kW]	Pt [kW]	γ	η	Fqam [N]	Fqem [N]	[kg]			
	ET030	23	5.25	86	450	0.25	0.50	26°33'	0.83	936	205	1,2	166	ET01
		20	7.25	62		0.16	0.41	19°26'	0.79	1033	205			
20		10.5	43		0.12	0.33	14°02'	0.74	1095	205				
20		14.5	31		0.10	0.27	10°00'	0.68	1265	205				
20		17	26		0.09	0.23	8°07'	0.63	1339	205				
18		21	21		0.07	0.22	7°07'	0.60	1487	205				
18		25	18		0.06	0.19	5°35'	0.54	1576	205				
17		29	16		0.05	0.18	5°02'	0.51	1688	205				
16		34	13		0.05	0.16	4°05'	0.46	1525	205				
14		42	11		0.04	0.15	3°22'	0.42	1702	205				
11		50	9.0		0.03	0.15	3°12'	0.41	1830	205				
7		60	7.5		0.02	0.14	2°45'	0.37	1830	205				
6	80	5.6		0.01	0.13	2°07'	0.35	2010	205					
ET040	52	8,0	56	450	0.37	0.85	26°33'	0.83	1953	360	2,4	170	ET02	
	48	10.5	43		0.27	0.70	19°26'	0.79	2164	360				
	52	12	38		0.27	0.58	14°22'	0.75	2208	360				
	47	16	28		0.19	0.56	14°02'	0.74	2560	360				
	45	21	21		0.15	0.46	10°00'	0.68	2694	360				
	39	25	18		0.12	0.38	8°07'	0.61	2781	360				
	37	32	14		0.10	0.31	7°07'	0.53	3018	360				
	32	42	11		0.08	0.28	5°02'	0.47	3400	360				
	31	50	9,0		0.07	0.25	4°05'	0.42	3400	360				
	26	62	7,3		0.06	0.22	3°22'	0.38	3400	360				
	24	80	5,6		0,04	0,20	2°51'	0,38	3400	360				
	21	100	4,5		0,03	0,16	2°25'	0,36	3400	360				
ET050	82	7.25	62	450	0.64	1.35	20°40'	0.83	2977	500	4,1	174	ET03	
	76	9.5	47		0.46	1.23	19°39'	0.82	3079	500				
	83	12	38		0.42	0.99	13°14'	0.77	3327	500				
	84	14.5	31		0.37	0.87	10°41'	0.74	3653	500				
	77	19	24		0.26	0.80	10°07'	0.72	3731	500				
	75	25	18		0.22	0.64	8°44'	0.65	4241	500				
	77	29	16		0.21	0.56	5°23'	0.60	4272	500				
	68	38	12		0.15	0.52	5°06'	0.57	4580	500				
	58	50	9		0.11	0.43	4°23'	0.48	4800	500				
	58	62	7.3		0.10	0.41	3°11'	0.45	4800	500				
	46	83	5.4		0.06	0.39	3°22'	0.42	4800	500				
	36	100	4.5		0.05	0.36	2°21'	0.38	4800	500				
ET063	154	7.25	62	450	1.18	2.32	20°36'	0.85	3691	700	6,4	178	ET04	
	138	9.75	46		0.81	2.02	20°40'	0.83	3968	700				
	128	12.75	35		0.58	1.90	19°39'	0.82	4417	700				
	160	14.5	31		0.68	1.47	10°39'	0.76	4178	700				
	141	19.5	23		0.46	1.36	10°41'	0.75	4778	700				
	129	25.5	18		0.34	1.18	10°07'	0.71	5555	700				
	147	29	16		0.39	0.89	5°22'	0.61	5266	700				
	128	39	12		0.26	0.84	5°23'	0.59	5781	700				
	113	51	8.8		0.19	0.80	5°06'	0.56	6200	700				
	111	61	7.4		0.18	0.65	3°16'	0.47	6200	700				
	95	82	5.5		0.12	0.62	3°11'	0.44	6200	700				
	61	100	4.5		0.08	0.55	2°12'	0.37	6200	700				



# E Serisi Motorsuz Güç Devir Sayfaları

## E Series Gear Units Performance Tables

### E Serien Getriebe Leistung und Drehzahlübersicht

450

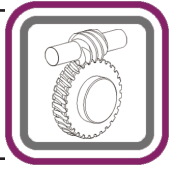

Tipi	Anma Momenti	Çevrim Oranı	Çıkış Devri	Giriş Devri	Güç Pe/Pt [kW] (Servis Faktörü fs=1,0 için) Pe=Mekanik Güç / Pt=Termik Güç				Güv. Rad.Yük Çıkış	Güv.Rad.Yük Giriş	Ağırlık	Ölçü Sayfası	Fiyat Kodu
	Nominal Torques	Ratio	Output speeds	Input Speeds	Power Pe/Pt [kW] (For Service Factor fs=1,0) Pe=Mechanical Power / Pt=Thermal Power				Per.O.Loads (Output)	Per.O.Loads (Input)	Weight	Dim. Page	Price Ref.
	Nenn-drehmomente	Übersetzung	Abtriebs-drehzahl	Antriebs-drehzahl	Leistung Pe/Pt [kW] (Bei Betriebsfaktor fs=1,0) Pe=Mechanische Leistung / Pt=Thermische Leistung				Zul.Querkräfte (Abtrieb)	Zul.Querkräfte (Antrieb)	Gewicht	Maße Seite	Preis Num.
	Ma [Nm]	i	n2 [rpm]	n1 [rpm]	Pe [kW]	Pt [kW]	γ	η	Fqam [N]	Fqem [N]	[kg]		
ET075	231	7.5	60	450	1.69	3.37	26°17'	0.86	5125	1100	9,2	182	ET05
	239	10	45		1.34	3.00	20°20'	0.84	5199	1100			
	245	15	30		0.98	2.24	13°52'	0.79	6122	1100			
	238	20	23		0.75	1.93	11°18'	0.75	6641	1100			
	228	25	18		0.61	1.63	9°32'	0.71	6780	1100			
	235	30	15		0.56	1.40	7°3'	0.66	7143	1100			
	220	40	11		0.42	1.27	5°43'	0.62	7472	1100			
	201	50	9.0		0.34	1.10	4°48'	0.56	8280	1100			
	188	60	7.5		0.29	0.98	4°8'	0.51	8918	1100			
	168	80	5.6		0.21	0.91	3°15'	0.47	10165	1100			
	133	100	4.5		0.15	0.82	2°40'	0.42	11361	1100			
ET080	310	7.5	60	450	2.28	3.73	21°48'	0.85	4944	1100	11	186	ET06
	288	10	45		1.61	3.50	20°36'	0.84	5094	1100			
	257	13.25	34		1.10	3.18	20°40'	0.83	5955	1100			
	323	15	30		1.32	2.38	11°18'	0.77	5547	1100			
	297	20	23		0.93	2.15	10°39'	0.75	6310	1100			
	260	26.5	17		0.64	1.96	10°41'	0.72	7632	1100			
	304	30	15		0.74	1.52	5°42'	0.64	7190	1100			
	269	40	11		0.52	1.39	5°22'	0.61	7400	1100			
	232	53	8.5		0.35	1.33	5°23'	0.59	7400	1100			
	189	62	7.3		0.29	1.07	3°13'	0.49	7400	1100			
	122	82	5.5		0.15	1.02	3°16'	0.47	7400	1100			
	85	110	4.1		0.08	0.97	3°11'	0.44	7400	1100			
	ET100	545	7.5	60	450	3.96	6.17	21°48'	0.87	4471			
494		10	45		2.73	5.66	21°48'	0.85	6738	1300			
456		13	35		1.97	5.05	20°36'	0.84	8565	1300			
577		15	30		2.27	4.09	11°18'	0.80	7911	1300			
512		20	23		1.55	3.68	11°18'	0.78	7472	1300			
465		26	17		1.11	3.41	10°39'	0.76	8200	1300			
543		30	15		1.28	2.47	5°42'	0.67	8200	1300			
476		40	11		0.88	2.26	5°42'	0.63	8200	1300			
417		52	8.7		0.63	2.06	5°22'	0.60	8200	1300			
389		63	7.1		0.55	1.75	3°22'	0.53	8200	1300			
250		82	5.5		0.29	1.65	3°13'	0.50	8200	1300			
159		107	4.2		0.15	1.54	3°16'	0.46	8200	1300			
ET125		995	7.25	62	450	7.30	11.08	21°48'	0.89	5400	1800	62,2	196
	899	10	45		4.89	9.37	21°48'	0.87	7937	1800			
	808	13	35		3.43	8.61	21°48'	0.85	8200	1800			
	1063	14.5	31		4.22	6.88	11°18'	0.82	8200	1800			
	944	20	23		2.79	6.23	11°18'	0.80	8200	1800			
	830	26	17		1.94	5.55	11°18'	0.77	8200	1800			
	1018	29	16		2.39	4.07	5°42'	0.69	8200	1800			
	880	40	11		1.56	3.75	5°42'	0.66	8200	1800			
	765	52	8.6		1.07	3.58	5°42'	0.65	8200	1800			
	800	62	7.2		1.11	2.79	3°24'	0.55	8200	1800			
	512	83	5.4		0.55	2.66	3°22'	0.53	8200	1800			
	326	107	4.2		0.29	2.50	3°13'	0.50	8200	1800			

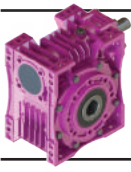

# E Serisi Motorsuz Güç Devir Sayfaları

## E Series Gear Units Performance Tables

### E Serien Getriebe Leistung und Drehzahlübersicht

750

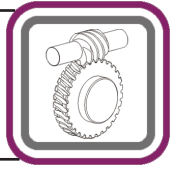

Tipi Type Typ	Anma Momenti	Çevrim Oranı	Çıkış Devri	Giriş Devri	Güç Pe/Pt [kW] (Servis Faktörü fs=1,0 için) Pe=Mekanik Güç / Pt=Termik Güç				Güv. Rad.Yük Çıkış	Güv.Rad.Yük Giriş	Ağırlık	Ölçü Sayfası	Fiyat Kodu
	Nominal Torques	Ratio	Output speeds	Input Speeds	Power Pe/Pt [kW] (For Service Factor fs=1,0) Pe=Mechanical Power / Pt=Thermal Power				Per.O.Loads (Output)	Per.O.Loads (Input)	Weight	Dim. Page	Price Ref.
	Nenn-drehmomente	Übersetzung	Abtriebs-drehzahl	Antriebs-drehzahl	Leistung Pe/Pt [kW] (Bei Betriebsfaktor fs=1,0) Pe=Mechanische Leistung / Pt=Thermische Leistung				Zul.Querkräfte (Abtrieb)	Zul.Querkräfte (Antrieb)	Gewicht	Maße Seite	Preis Num.
	Ma [Nm]	i	n2 [rpm]	n1 [rpm]	Pe [kW]	Pt [kW]	γ	η	Fqam [N]	Fqem [N]	[kg]		
ET030	21	5.25	143	750	0.36	0.63	26°33'	0.87	754	189	1,2	166	ET01
	19	7.25	103		0.25	0.51	19°26'	0.84	847	205			
	19	10.5	71		0.18	0.39	14°02'	0.78	902	205			
	19	14.5	52		0.14	0.31	10°00'	0.72	1043	205			
	19	17	44		0.13	0.27	8°07'	0.68	1103	205			
	18	21	36		0.10	0.24	7°07'	0.65	1227	205			
	18	25	30		0.10	0.21	5°35'	0.60	1299	205			
	18	29	26		0.08	0.20	5°02'	0.57	1392	205			
	17	34	22		0.08	0.18	4°05'	0.52	1256	205			
	16	42	18		0.06	0.16	3°22'	0.48	1384	205			
	13	50	15		0.04	0.16	3°12'	0.47	1563	205			
	9	60	13		0.03	0.15	2°45'	0.43	1726	205			
8	80	9,4		0.02	0,14	2°07'	0,41	1828	205				
ET040	48	8.0	94	750	0.55	1.04	26°33'	0.86	1567	360	2,4	170	ET02
	46	10.5	71		0.41	0.85	19°26'	0.83	1760	360			
	49	12	63		0.41	0.70	14°22'	0.79	1789	360			
	45	16	47		0.29	0.65	14°02'	0.78	2096	360			
	43	21	36		0.22	0.53	10°00'	0.73	2213	360			
	39	25	30		0.18	0.44	8°07'	0.67	2278	360			
	38	32	23		0.16	0.35	7°07'	0.59	2465	360			
	36	42	18		0.13	0.31	5°02'	0.53	2858	360			
	34	50	15		0.11	0.28	4°05'	0.48	3030	360			
	27	62	12		0.08	0.24	3°22'	0.43	3172	360			
	27	80	9,3		0,06	0,21	2°51'	0,43	3432	360			
	25	100	7,5		0,05	0,17	2°25'	0,40	3883	360			
ET050	75	7.25	103	750	0.95	1.52	20°40'	0.86	2394	500	4,1	174	ET03
	70	9.5	78		0.69	1.36	19°39'	0.84	2508	500			
	77	12	63		0.63	1.08	13°14'	0.80	2704	500			
	79	14.5	52		0.55	0.96	10°41'	0.77	2977	500			
	72	19	39		0.40	0.87	10°07'	0.75	3064	500			
	75	25	30		0.33	0.78	8°44'	0.72	3487	500			
	75	29	26		0.32	0.60	5°23'	0.64	3493	500			
	67	38	20		0.23	0.56	5°06'	0.60	3767	500			
	63	50	15		0.18	0.51	4°23'	0.56	4311	500			
	59	62	12		0.15	0.44	3°11'	0.50	4634	500			
	50	83	9		0.10	0.43	3°22'	0.48	4370	500			
	50	100	7,5		0,09	0,39	2°21'	0,44	4640	500			
ET063	142	7.25	103	750	1.75	2.72	20°36'	0.87	2958	700	6,4	178	ET04
	127	9.75	77		1.21	2.25	20°40'	0.85	3229	700			
	119	12.75	59		0.87	2.11	19°39'	0.84	3627	700			
	150	14.5	52		1.02	1.65	10°39'	0.79	3398	700			
	133	19.5	38		0.69	1.51	10°41'	0.77	3928	700			
	122	25.5	29		0.52	1.25	10°08'	0.73	4577	700			
	145	29	26		0.60	0.99	5°22'	0.66	4287	700			
	126	39	19		0.41	0.91	5°23'	0.62	4752	700			
	112	51	15		0.29	0.85	5°06'	0.60	5515	700			
	116	61	12		0.29	0.70	3°16'	0.52	5570	700			
	97	82	9		0.19	0.65	3°11'	0.48	6200	700			
	68	100	7,5		0.13	0.58	2°12'	0.41	6200	700			



# E Serisi Motorsuz Güç Devir Sayfaları

## E Series Gear Units Performance Tables

### E Serien Getriebe Leistung und Drehzahlübersicht

750

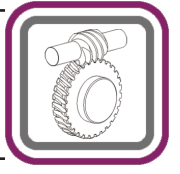

Tipi	Anma Momenti	Çevrim Oranı	Çıkış Devri	Giriş Devri	Güç Pe/Pt [kW] (Servis Faktörü fs=1,0 için) Pe=Mekanik Güç / Pt=Termik Güç				Güv. Rad.Yük Çıkış	Güv.Rad.Yük Giriş	Ağırlık	Ölçü Sayfası	Fiyat Kodu
Type	Nominal Torques	Ratio	Output speeds	Input Speeds	Power Pe/Pt [kW] (For Service Factor fs=1,0) Pe=Mechanical Power / Pt=Thermal Power				Per.O.Loads (Output)	Per.O.Loads (Input)	Weight	Dim. Page	Price Ref.
Typ	Nenn-drehmomente	Übersetzung	Abtriebs-drehzahl	Antriebs-drehzahl	Leistung Pe/Pt [kW] (Bei Betriebsfaktor fs=1,0) Pe=Mechanische Leistung / Pt=Thermische Leistung				Zul.Querkräfte (Abtrieb)	Zul.Querkräfte (Antrieb)	Gewicht	Maße Seite	Preis Num.
	Ma [Nm]	i	n2 [rpm]	n1 [rpm]	Pe [kW]	Pt [kW]	γ	η	Fqam [N]	Fqem [N]	[kg]		
ET075	210	7.5	100	750	2.53	3.62	26°17'	0.87	4073	1018	9,2	182	ET05
	219	10	75		2.01	3.30	20°20'	0.86	4189	1047			
	227	15	50		1.48	2.44	13°53'	0.81	4967	1100			
	224	20	38		1.14	2.08	11°18'	0.77	5412	1100			
	219	25	30		0.93	1.78	9°32'	0.74	5541	1100			
	227	30	25		0.87	1.51	7°3'	0.69	5819	1100			
	213	40	19		0.64	1.35	5°43'	0.65	6124	1100			
	202	50	15		0.52	1.20	4°48'	0.61	6796	1100			
	193	60	13		0.46	1.05	4°08'	0.55	7306	1100			
	172	80	9.4		0.33	0.96	3°15'	0.51	8374	1100			
146	100	7.5		0.25	0.87	2°40'	0.46	9307	1100				
ET080	284	7.5	100	750	3.40	4.27	21°48'	0.88	3912	978	11	186	ET06
	265	10	75		2.40	4.02	20°36'	0.87	4120	1030			
	237	13.25	57		1.66	3.55	20°40'	0.85	4873	1100			
	307	15	50		1.98	2.83	11°18'	0.81	4480	1100			
	279	20	38		1.44	2.35	10°39'	0.77	5141	1100			
	246	26.5	28		0.98	2.08	10°41'	0.74	6269	1100			
	300	30	25		1.14	1.72	5°42'	0.69	5839	1100			
	268	40	19		0.80	1.55	5°22'	0.66	6452	1100			
	230	53	14		0.55	1.42	5°23'	0.63	6920	1100			
	207	62	12		0.49	1.16	3°13'	0.54	7090	1100			
	136	82	9.1		0.25	1.10	3°16'	0.52	7400	1100			
	93	110	6.8		0.14	1.01	3°11'	0.47	7400	1100			
ET100	502	7.5	100	750	5.89	7.53	21°48'	0.89	3777	944	31,7	190	ET07
	454	10.	75		4.08	6.47	21°48'	0.87	5370	1300			
	420	13	58		2.97	5.62	20°36'	0.86	6922	1300			
	546	15	50		3.40	5.05	11°18'	0.84	6313	1300			
	488	20	38		2.35	4.42	11°18'	0.82	6065	1300			
	441	26	29		1.70	3.79	10°39'	0.79	7336	1300			
	544	30	25		1.96	2.99	5°42'	0.73	6678	1300			
	473	40	19		1.36	2.54	5°42'	0.68	7598	1300			
	419	52	14		0.99	2.27	5°22'	0.64	7953	1300			
	434	63	12		0.92	1.98	3°21'	0.59	8200	1300			
	274	82	9.1		0.48	1.79	3°13'	0.55	8200	1300			
	177	107	7,0		0.25	1.67	3°16'	0.51	8200	1300			
	ET125	912	7.25	103	750	10.83	14.06	21°48'	0.91	5341			
831		10	75		7.31	11.46	21°48'	0.89	6231	1558			
746		13	58		5.15	9.85	21°48'	0.87	8625	1800			
1002		14.5	52		6.33	8.63	11°19'	0.86	6859	1800			
899		20	38		4.20	7.68	11°19'	0.84	8361	1800			
797		26	29		2.96	6.63	11°19'	0.81	10512	1800			
1015		29	26		3.64	5.03	5°43'	0.75	8637	1800			
889		40	19		2.40	4.55	5°43'	0.73	10003	1800			
767		52	14		1.65	4.12	5°43'	0.70	10959	1800			
847		62	12		1.73	3.26	3°24'	0.62	10691	1800			
572		83	9.0		0.92	3.01	3°22'	0.59	11717	1800			
357		107	7.0		0.48	2.72	3°13'	0.55	11842	1800			



# E Serisi Motorsuz Güç Devir Sayfaları

## E Series Gear Units Performance Tables

### E Serien Getriebe Leistung und Drehzahlübersicht

900

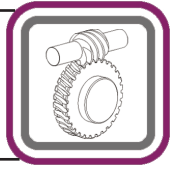

Tipi Type Typ	Anma Momenti	Çevrim Oranı	Çıkış Devri	Giriş Devri	Güç Pe/Pt [kW] (Servis Faktörü fs=1,0 için) Pe=Mekanik Güç / Pt=Termik Güç				Güv. Rad.Yük Çıkış	Güv.Rad.Yük Giriş	Ağırlık	Ölçü Sayfası	Fiyat Kodu
	Nominal Torques	Ratio	Output speeds	Input Speeds	Power Pe/Pt [kW] (For Service Factor fs=1,0) Pe=Mechanical Power / Pt=Thermal Power				Per.O.Loads (Output)	Per.O.Loads (Input)	Weight	Dim. Page	Price Ref.
	Nenn-drehmomente	Übersetzung	Abtriebs-drehzahl	Antriebs-drehzahl	Leistung Pe/Pt [kW] (Bei Betriebsfaktor fs=1,0) Pe=Mechanische Leistung / Pt=Thermische Leistung				Zul.Querkräfte (Abtrieb)	Zul.Querkräfte (Antrieb)	Gewicht	Maße Seite	Preis Num.
	Ma [Nm]	i	n2 [rpm]	n1 [rpm]	Pe [kW]	Pt [kW]	$\gamma$	$\eta$	Fqam [N]	Fqem [N]	[kg]		
ET030	20	5.25	171	900	0.42	0.64	26°33'	0.87	699	175	1,2	166	ET01
	18	7.25	124		0.28	0.52	19°26'	0.84	790	197			
	18	10.5	86		0.20	0.40	14°02'	0.79	842	205			
	19	14.5	62		0.17	0.32	10°00'	0.74	974	205			
	19	17	53		0.15	0.28	8°07'	0.70	1030	205			
	18	21	43		0.12	0.25	7°07'	0.67	1146	205			
	18	25	36		0.11	0.22	5°35'	0.62	1213	205			
	18	29	31		0.10	0.21	5°02'	0.59	1301	205			
	17	34	26		0.09	0.18	4°05'	0.54	1174	205			
	16	42	21		0.07	0.17	3°22'	0.51	1293	205			
	13	50	18		0.06	0.16	3°12'	0.49	1456	205			
	9	60	15		0.05	0.15	2°45'	0.45	1613	205			
	14	80	11		0.04	0,14	2°07'	0,44	1773	205			
ET040	46	8	113	900	0.63	1.05	26°33'	0.86	1449	360	2,4	170	ET02
	44	10.5	86		0.47	0.86	19°26'	0.83	1637	360			
	48	12	75		0.47	0.73	14°22'	0.80	1660	360			
	44	16	56		0.33	0.66	14°02'	0.78	1953	360			
	43	21	43		0.26	0.56	10°00'	0.74	2066	360			
	39	25	36		0.21	0.45	8°07'	0.68	2123	360			
	38	32	28		0.18	0.37	7°07'	0.61	2297	360			
	37	42	21		0.15	0.33	5°02'	0.56	2646	360			
	34	50	18		0.13	0.29	4°05'	0.51	2826	360			
	26	62	15		0.09	0.25	3°22'	0.46	2957	360			
	28	80	11		0,07	0,22	2°51'	0,46	3199	360			
	22	100	9,0		0,05	0,19	2°25'	0,43	3620	360			
	ET050	72	7.25	124	900	1.09	1.59	20°40'	0.86	2216			
68		9.5	95		0.79	1.41	19°39'	0.85	2333	500			
74		12	75		0.73	1.12	13°14'	0.80	2513	500			
77		14.5	62		0.64	1.00	10°41'	0.78	2770	500			
71		19	47		0.46	0.90	10°07'	0.76	2857	500			
73		25	36		0.38	0.79	8°44'	0.72	3257	500			
74		29	31		0.37	0.63	5°06'	0.65	3254	500			
67		38	24		0.27	0.57	5°23'	0.62	3517	500			
62		50	18		0.20	0.51	4°23'	0.57	4030	500			
59		62	15		0.17	0.45	3°11'	0.51	4331	500			
51		83	11		0.11	0.45	3°22'	0.51	4093	500			
43		100	9,0		0,09	0,45	2°21'	0,46	4346	500			
ET063		137	7.25	124	900	2.02	2.89	20°36'	0.88	2735	700	6,4	178
	123	9.75	92		1.39	2.33	20°40'	0.85	3001	700			
	115	12.75	71		1.01	2.19	19°39'	0.85	3383	700			
	148	14.5	62		1.18	1.81	10°39'	0.81	3159	700			
	130	19.5	46		0.80	1.58	10°41'	0.79	3665	700			
	119	25.5	35		0.60	1.29	10°07'	0.74	4274	700			
	144	29	31		0.70	1.03	5°22'	0.67	3988	700			
	112	39	23		0.47	0.94	5°23'	0.64	4434	700			
	123	51	18		0.34	0.87	5°06'	0.61	5157	700			
	117	61	15		0.34	0.73	3°16'	0.53	5196	700			
	98	82	11		0.23	0.67	3°11'	0.49	6138	700			
	71	100	9,0		0.16	0.59	2°12'	0.43	6087	700			



# E Serisi Motorsuz Güç Devir Sayfaları

## E Series Gear Units Performance Tables

### E Serien Getriebe Leistung und Drehzahlübersicht

900

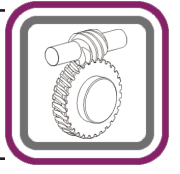

Tipi	Anma Momenti	Çevrim Oranı	Çıkış Devri	Giriş Devri	Güç Pe/Pt [kW] (Servis Faktörü $f_s=1,0$ için) Pe=Mekanik Güç / Pt=Termik Güç				Güv. Rad.Yük Çıkış	Güv.Rad.Yük Giriş	Ağırlık	Ölçü Sayfası	Fiyat Kodu
	Nominal Torques	Ratio	Output speeds	Input Speeds	Power Pe/Pt [kW] (For Service Factor $f_s=1,0$ ) Pe=Mechanical Power / Pt=Thermal Power				Per.O.Loads (Output)	Per.O.Loads (Input)	Weight	Dim. Page	Price Ref.
	Nenn-drehmomente	Übersetzung	Abtriebs-drehzahl	Antriebs-drehzahl	Leistung Pe/Pt [kW] (Bei Betriebsfaktor $f_s=1,0$ ) Pe=Mechanische Leistung / Pt=Thermische Leistung				Zul.Querkräfte (Abtrieb)	Zul.Querkräfte (Antrieb)	Gewicht	Maße Seite	Preis Num.
	Ma [Nm]	i	n2 [rpm]	n1 [rpm]	Pe [kW]	Pt [kW]	$\gamma$	$\eta$	Fqam [N]	Fqem [N]	[kg]		
ET075	204	7.50	120	900	2.91	3.85	26°17'	0.88	3752	1100	9,2	182	ET05
	214	10	90		2.32	3.54	20°20'	0.87	3880	1100			
	223	15	60		1.71	2.61	13°52'	0.82	4613	1100			
	219	20	45		1.32	2.15	11°18'	0.78	5035	1100			
	214	25	36		1.09	1.84	9°32'	0.74	5156	1100			
	227	30	30		1.01	1.60	7°3'	0.71	5412	1100			
	214	40	23		0.75	1.44	5°43'	0.67	5708	1100			
	202	50	18		0.61	1.25	4°48'	0.62	6335	1100			
	193	60	15		0.54	1.08	4°8'	0.57	6805	1100			
	174	80	11		0.39	0.99	3°15'	0.53	7816	1100			
	152	100	9.0		0.30	0.89	2°40'	0.47	8655	1100			
ET080	276	7.5	120	900	3.92	4.56	21°48'	0.88	3598	1100	11	186	ET06
	257	10	90		2.77	4.22	20°36'	0.87	3822	1100			
	230	13.25	68		1.91	3.69	20°40'	0.86	4540	1100			
	300	15	60		2.29	3.00	11°18'	0.82	4154	1100			
	276	20	45		1.65	2.51	10°39'	0.79	4782	1100			
	241	26.5	34		1.14	2.14	10°41'	0.75	5850	1100			
	300	30	30		1.32	1.85	5°42'	0.71	5427	1100			
	266	40	23		0.93	1.62	5°22'	0.67	6013	1100			
	230	53	17		0.64	1.47	5°23'	0.64	6466	1100			
	220	62	15		0.59	1.23	3°13'	0.57	6559	1100			
	141	82	11		0.30	1.14	3°16'	0.54	7212	1100			
	96	110	8.2		0.17	1.04	3°11'	0.49	7400	1100			
	ET100	486	7.5	120	900	6.79	8.03	21°48'	0.90	3622	1300	31,7	190
441		10	90		4.71	6.89	21°48'	0.88	4953	1300			
408		13	69		3.43	5.82	20°36'	0.86	6419	1300			
533		15	60		3.93	5.47	11°18'	0.85	5830	1300			
478		20	45		2.72	4.70	11°18'	0.83	5634	1300			
436		26	35		1.96	4.11	10°39'	0.80	6835	1300			
540		30	30		2.27	3.21	5°42'	0.75	6189	1300			
474		40	23		1.59	2.70	5°42'	0.70	7064	1300			
418		52	17		1.15	2.35	5°22'	0.66	7412	1300			
456		63	14		1.10	2.11	3°21'	0.62	7598	1300			
290		82	11		0.58	1.91	3°13'	0.58	8200	1300			
183		107	8.4		0.30	1.72	3°16'	0.53	8200	1300			
ET125		874	7.25	124	900	12.46	13.93	21°48'	0.91	5116	1800	62,2	194
	805	10	90		8.43	12.20	21°48'	0.90	5717	1800			
	725	13	69		5.95	10.50	21°48'	0.88	7981	1800			
	963	14.5	62		7.30	8.56	11°18'	0.86	6282	1800			
	879	20	45		4.86	8.32	11°18'	0.85	7748	1800			
	782	26	35		3.43	7.04	11°18'	0.83	9778	1800			
	987	29	31		4.22	5.10	5°42'	0.76	7960	1800			
	885	40	23		2.78	4.89	5°42'	0.75	9291	1800			
	769	52	17		1.93	4.44	5°42'	0.72	10214	1800			
	866	62	15		2.01	3.54	3°24'	0.65	9936	1800			
	601	83	11		1.10	3.22	3°22'	0.62	11526	1800			
	379	107	8.4		0.58	2.91	3°13'	0.58	12045	1800			

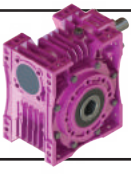

# E Serisi Motorsuz Güç Devir Sayfaları

## E Series Gear Units Performance Tables

### E Serien Getriebe Leistung und Drehzahlübersicht

1400

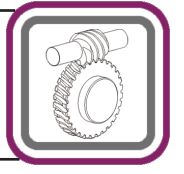

Tipi Type Typ	Anma Momenti Nominal Torques Nenn-drehmomente	Çevrim Oranı Ratio Übersetzung	Çıkış Devri Output speeds Abtriebs-drehzahl	Giriş Devri Input Speeds Antriebs-drehzahl	Güç Pe/Pt [kW] (Servis Faktörü fs=1,0 için) Pe=Mekanik Güç / Pt=Termik Güç Power Pe/Pt [kW] (For Service Factor fs=1,0) Pe=Mechanical Power / Pt=Thermal Power Leistung Pe/Pt [kW] (Bei Betriebsfaktor fs=1,0) Pe=Mechanische Leistung / Pt=Thermische Leistung				Güv. Rad.Yük Çıkış Per.O.Loads (Output) Zul.Querkräfte (Abtrieb)	Güv.Rad.Yük Giriş Per.O.Loads (Input) Zul.Querkräfte (Antrieb)	Ağırlık Weight Gewicht	Ölçü Sayfası Dim. Page Maße Seite	Fiyat Kodu Price Ref. Preis Num.	
	Ma [Nm]	i	n2 [rpm]	n1 [rpm]	Pe [kW]	Pt [kW]	γ	η	Fqam [N]	Fqem [N]	[kg]			
	ET030	19	5.25	267	1400	0.59	0.71	26°33'	0.88	579	145	1,2	166	ET01
		17	7.25	193		0.40	0.57	19°26'	0.86	665	166			
17		10.5	133		0.29	0.44	14°02'	0.81	712	178				
18		14.5	97		0.24	0.35	10°00'	0.76	824	206				
18		17	82		0.21	0.30	8°07'	0.73	871	218				
17		21	67		0.17	0.26	7°07'	0.69	972	243				
17		25	56		0.16	0.23	5°35'	0.65	1026	205				
17		29	48		0.14	0.22	5°02'	0.62	1101	205				
17		34	41		0.13	0.19	4°05'	0.57	992	205				
16		42	33		0.10	0.18	3°22'	0.55	1097	205				
14		50	28		0.08	0.17	3°12'	0.52	1222	205				
10		60	23		0.05	0.16	2°45'	0.48	1364	205				
10	80	18		0,04	0,15	2°09'	0,46	1500	205					
ET040	42	8	175	1400	0.89	1.16	26°33'	0.88	1194	298	2,4	170	ET02	
	41	10.5	133		0.67	0.94	19°26'	0.85	1366	341				
	45	12	117		0.66	0.80	14°22'	0.82	1382	345				
	41	16	88		0.47	0.72	14°02'	0.80	1642	360				
	40	21	67		0.37	0.60	10°00'	0.77	1743	360				
	37	25	56		0.30	0.49	8°07'	0.71	1790	360				
	37	32	44		0.26	0.40	7°07'	0.65	1929	360				
	36	42	33		0.21	0.35	5°02'	0.60	2228	360				
	34	50	28		0.18	0.31	4°05'	0.55	2380	360				
	49	62	23		0.21	0.31	3°22'	0.55	2491	360				
	32	80	18		0,12	0,24	2°51'	0,50	2695	360				
	29	100	14		0,09	0,20	2°25'	0,49	3050	360				
ET050	67	7.25	193	1400	1.53	1.83	20°40'	0.88	1830	458	4,1	174	ET03	
	63	9.5	147		1.12	1.61	19°39'	0.87	1951	488				
	70	12	117		1.03	1.29	13°14'	0.83	2098	500				
	73	14.5	97		0.90	1.18	10°41'	0.82	2318	500				
	67	19	74		0.66	1.03	10°07'	0.79	2411	500				
	70	25	56		0.54	0.89	8°44'	0.76	2749	500				
	74	29	48		0.53	0.73	5°23'	0.71	2736	500				
	66	38	37		0.38	0.65	5°06'	0.67	2971	500				
	63	50	28		0.29	0.57	4°23'	0.62	3412	500				
	61	62	23		0.25	0.51	3°11'	0.58	3669	500				
	51	83	17		0.16	0.47	3°22'	0.55	3484	500				
	48	100	14		0,14	0,43	2°21'	0,50	3700	500				
ET063	126	7.25	193	1400	2.83	3.45	20°37'	0.90	2257	564	6,4	178	ET04	
	114	9.75	144		1.97	2.60	20°40'	0.87	2507	627				
	107	12.75	110		1.42	2.49	19°39'	0.87	2851	713				
	139	14.5	97		1.66	2.12	10°39'	0.84	2644	661				
	124	19.5	72		1.13	1.89	10°41'	0.82	3097	700				
	114	25.5	55		0.86	1.42	10°08'	0.77	3611	700				
	142	29	48		0.99	1.19	5°22'	0.72	3340	700				
	124	39	36		0.68	1.06	5°23'	0.69	3742	700				
	112	51	28		0.49	0.98	5°06'	0.66	4371	700				
	120	61	23		0.49	0.81	3°16'	0.59	4376	700				
	103	82	17		0.33	0.73	3°11'	0.55	5193	700				
	82	100	14		0.25	0.64	2°26'	0.48	5294	700				



# E Serisi Motorsuz Güç Devir Sayfaları

## E Series Gear Units Performance Tables

### E Serien Getriebe Leistung und Drehzahlübersicht

1400

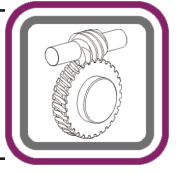

Tipi	Anma Momenti	Çevrim Oranı	Çıkış Devri	Giriş Devri	Güç Pe/Pt [kW] (Servis Faktörü fs=1,0 için) Pe=Mekanik Güç / Pt=Termik Güç				Güv. Rad.Yük Çıkış	Güv.Rad.Yük Giriş	Ağırlık	Ölçü Sayfası	Fiyat Kodu
	Nominal Torques	Ratio	Output speeds	Input Speeds	Power Pe/Pt [kW] (For Service Factor fs=1,0) Pe=Mechanical Power / Pt=Thermal Power				Per.O.Loads (Output)	Per.O.Loads (Input)	Weight	Dim. Page	Price Ref.
	Nenn-drehmomente	Übersetzung	Abtriebs-drehzahl	Antriebs-drehzahl	Leistung Pe/Pt [kW] (Bei Betriebsfaktor fs=1,0) Pe=Mechanische Leistung / Pt=Thermische Leistung				Zul.Querkräfte (Abtrieb)	Zul.Querkräfte (Antrieb)	Gewicht	Maße Seite	Preis Num.
	Ma [Nm]	i	n2 [rpm]	n1 [rpm]	Pe [kW]	Pt [kW]	$\gamma$	$\eta$	Fqam [N]	Fqem [N]	[kg]		
ET075	187	7.5	187	1400	4.11	4.16	26°17'	0.89	3405	851	9,2	182	ET05
	197	10	140		3.27	3.90	20°20'	0.88	3210	802			
	209	15	93		2.42	2.96	13°52'	0.84	3847	962			
	207	20	70		1.88	2.40	11°18'	0.81	4214	1054			
	206	25	56		1.55	2.06	9°32'	0.78	4326	1082			
	219	30	47		1.45	1.76	7°3'	0.74	4526	1131			
	211	40	35		1.07	1.64	5°43'	0.72	4807	1100			
	204	50	28		0.88	1.42	4°48'	0.68	5342	1100			
	196	60	23		0.78	1.18	4°8'	0.61	5718	1100			
	183	80	18		0.57	1.12	3°15'	0.59	6612	1100			
	171	100	14		0.47	1.00	2°40'	0.54	7250	1100			
ET080	251	7.5	187	1400	5.52	4.69	21°48'	0.89	2933	733	11	186	ET06
	237	10	140		3.90	4.84	20°36'	0.89	3188	797			
	214	13.25	106		2.70	4.14	20°40'	0.87	3825	956			
	278	15	93		3.24	3.23	11°18'	0.84	3467	867			
	260	20	70		2.34	2.75	10°39'	0.81	4013	1003			
	231	26.5	53		1.64	2.36	10°41'	0.78	4938	1100			
	287	30	47		1.88	2.04	5°42'	0.75	4537	1100			
	264	40	35		1.34	1.87	5°22'	0.72	5074	1100			
	230	53	26		0.92	1.67	5°23'	0.69	5481	1100			
	244	62	23		0.91	1.41	3°13'	0.63	5396	1100			
	157	82	17		0.47	1.28	3°16'	0.59	6078	1100			
	108	110	13		0.26	1.14	3°11'	0.55	7134	1100			
	ET100	438	7.5	187	1400	9.54	7.58	21°48'	0.90	3494	874	31,7	190
403		10	140		6.64	7.07	21°48'	0.89	4079	1020			
378		13	108		4.86	6.37	20°36'	0.88	5346	1337			
484		15	93		5.53	5.46	11°18'	0.86	4829	1207			
444		20	70		3.85	5.13	11°18'	0.85	4731	1183			
412		26	54		2.79	4.68	10°39'	0.83	5747	1300			
500		30	47		3.22	3.28	5°42'	0.76	5134	1300			
456		40	35		2.29	2.92	5°42'	0.73	5927	1300			
416		52	27		1.67	2.66	5°22'	0.70	6241	1300			
446		63	22		1.59	2.26	3°21'	0.65	6384	1300			
322		82	17		0.90	2.20	3°13'	0.64	7024	1300			
204		107	13		0.47	1.92	3°16'	0.59	7188	1300			
ET125		787	7.25	193	1400	17.45	13.60	21°48'	0.91	4910	1227	62,2	194
	726	10	140		11.88	11.52	21°48'	0.90	4764	1191			
	664	13	108		8.41	10.79	21°48'	0.89	6633	1658			
	871	14.5	97		10.28	8.36	11°18'	0.86	5106	1277			
	801	20	70		6.86	8.30	11°18'	0.86	6467	1617			
	729	26	54		4.88	7.62	11°18'	0.84	8227	1800			
	900	29	48		5.99	5.00	5°42'	0.76	6515	1800			
	823	40	35		3.97	5.00	5°42'	0.76	7794	1800			
	744	52	27		2.76	5.00	5°42'	0.76	8630	1800			
	803	62	23		2.90	3.46	3°24'	0.65	8297	1800			
	632	83	17		1.71	3.44	3°22'	0.65	9580	1800			
	420	107	13		0.90	3.35	3°13'	0.64	10191	1800			

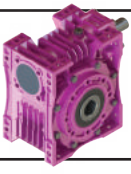

# E Serisi Motorsuz Güç Devir Sayfaları

## E Series Gear Units Performance Tables

### E Serien Getriebe Leistung und Drehzahlübersicht

2800

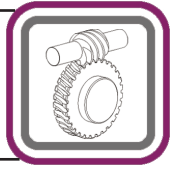

Tipi Type Typ	Anma Momenti Nominal Torques Nenn-drehmomente Ma [Nm]	Çevrim Oranı Ratio Übersetzung i	Çıkış Devri Output speeds Abtriebs-drehzahl n2 [rpm]	Giriş Devri Input Speeds Antriebs-drehzahl n1 [rpm]	Güç Pe/Pt [kW] (Servis Faktörü fs=1,0 için) Pe=Mekanik Güç / Pt=Termik Güç Power Pe/Pt [kW] (For Service Factor fs=1,0) Pe=Mechanical Power / Pt=Thermal Power Leistung Pe/Pt [kW] (Bei Betriebsfaktor fs=1,0) Pe=Mechanische Leistung / Pt=Thermische Leistung				Güv. Rad.Yük Çıkış Per.O.Loads (Output) Zul.Querkräfte (Abtrieb) Fqam [N]	Güv.Rad.Yük Giriş Per.O.Loads (Input) Zul.Querkräfte (Antrieb) Fqem [N]	Ağırlık Weight Gewicht [kg]	Ölçü Sayfası Dim. Page Maße Seite	Fiyat Kodu Price Ref. Preis Num.				
					Pe [kW]	Pt [kW]	γ	η									
ET030	16	5.25	533	2800	0.99	0.88	26°33'	0.91	461	115	1,2	166	ET01				
	15	7.25	386		0.67	0.70	19°26'	0.89	507	127							
	15	10.5	267		0.49	0.53	14°02'	0.85	546	136							
	16	14.5	193		0.40	0.43	10	0.82	634	159							
	17	17	165		0.37	0.37	8°07'	0.79	670	168							
	16	21	133		0.30	0.32	7°07'	0.75	748	187							
	17	25	112		0.28	0.28	5°35'	0.72	790	197							
	17	29	97		0.24	0.26	5°02'	0.70	849	205							
	17	34	82		0.22	0.23	4°05'	0.65	764	205							
	16	42	67		0.17	0.22	3°25'	0.64	852	205							
	15	50	56		0.14	0.21	3°12'	0.63	938	205							
	12	60	47		0.10	0.19	2°45'	0.58	1040	205							
	12	80	35		0.08	0,018	2°07'	0,56	1155	205							
ET040	37	8	350	2800	1.51	1.37	26°33'	0.90	1000	250	2,4	170	ET02				
	36	10.5	267		1.14	1.10	19°26'	0.88	1029	257							
	40	12	233		1.14	0.93	14°22'	0.85	1033	258							
	37	16	175		0.81	0.83	14°02'	0.84	1249	312							
	37	21	133		0.63	0.75	10°00'	0.82	1338	335							
	35	25	112		0.52	0.63	8°07'	0.79	1372	343							
	36	32	88		0.44	0.51	7°07'	0.74	1478	360							
	36	42	67		0.37	0.44	5°02'	0.69	1712	360							
	34	50	56		0.31	0.38	4°05'	0.64	1827	360							
	28	62	45		0.23	0.33	3°22'	0.58	1909	360							
	28	80	35		0,18	0,29	2°51'	0,58	2065	360							
	26	100	28		0,14	0,24	2°25'	0,58	2337	360							
	ET050	57	7.25	386	2800	2.62	1.81	20°4'	0.89	1348				337	4,1	174	ET03
54		9.5	295		1.92	1.64	19°39'	0.87	1470	368							
61		12	233		1.76	1.29	13°14'	0.84	1576	394							
64		14.5	193		1.54	1.23	140°41'	0.83	1757	439							
60		19	147		1.13	1.14	10°07'	0.82	1847	462							
64		25	112		0.94	1.01	8°44'	0.80	2113	590							
66		29	97		0.91	0.76	5°06'	0.73	2088	590							
61		38	74		0.67	0.72	5°23'	0.71	2288	590							
60		50	56		0.52	0.64	4°23'	0.68	2635	590							
59		62	45		0.44	0.57	3°11'	0.64	2840	590							
52		83	34		0.29	0.58	3°22'	0.64	2717	590							
49		100	28		0,25	0,53	2°21'	0,58	2885	590							
ET063		109	7.25	386	2800	4.79	3.96	20°36'	0.92	1655	414	6,4	178	ET04			
	104	9.75	287		3.6	2.47	20°40'	0.87	1883	471							
	93	12.75	220		2.44	2.53	19°39'	0.88	2180	545							
	118	14.5	193		2.83	2.05	10°39'	0.85	2000	500							
	104	19.5	144		1.96	2.02	10°41'	0.84	2381	595							
	102	25.5	110		1.50	1.45	10°07'	0.78	2772	693							
	122	29	97		1.72	1.12	5°22'	0.72	2529	632							
	112	39	72		1.31	1.07	5°23'	0.71	2869	700							
	115	51	55		0.95	1.06	5°06'	0.70	3381	700							
	111	61	46		0.88	0.82	3°16'	0.61	3352	700							
	108	82	34		0.65	0.78	3°11'	0.59	4004	700							
	106	100	28		0.60	0.67	2°12'	0.52	3851	700							



# E Serisi Motorsuz Güç Devir Sayfaları

## E Series Gear Units Performance Tables

### E Serien Getriebe Leistung und Drehzahlübersicht

2800

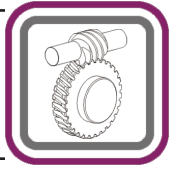

Tipi	Anma Momenti	Çevrim Oranı	Çıkış Devri	Giriş Devri	Güç Pe/Pt [kW] (Servis Faktörü fs=1,0 için) Pe=Mekanik Güç / Pt=Termik Güç				Güv. Rad.Yük Çıkış	Güv.Rad.Yük Giriş	Ağırlık	Ölçü Sayfası	Fiyat Kodu
Type	Nominal Torques	Ratio	Output speeds	Input Speeds	Power Pe/Pt [kW] (For Service Factor fs=1,0) Pe=Mechanical Power / Pt=Thermal Power				Per.O.Loads (Output)	Per.O.Loads (Input)	Weight	Dim. Page	Price Ref.
Typ	Nenn-drehmomente	Übersetzung	Abtriebs-drehzahl	Antriebs-drehzahl	Leistung Pe/Pt [kW] (Bei Betriebsfaktor fs=1,0) Pe=Mechanische Leistung / Pt=Thermische Leistung				Zul.Querkräfte (Abtrieb)	Zul.Querkräfte (Antrieb)	Gewicht	Maße Seite	Preis Num.
	Ma [Nm]	i	n2 [rpm]	n1 [rpm]	Pe [kW]	Pt [kW]	γ	η	Fqam [N]	Fqem [N]	[kg]		
ET075	161	7.5	373	2800	7.07	3.98	26°17'	0.89	3092	773	9,2	182	ET05
	167	10	280		5.61	3.47	20°20'	0.87	2370	592			
	178	15	187		4.19	2.63	13°52'	0.83	2876	719			
	179	20	140		3.28	2.21	11°18'	0.80	3176	794			
	179	25	112		2.73	1.92	9°32'	0.77	3271	818			
	190	30	93		2.55	1.61	7°30'	0.73	3407	852			
	186	40	70		1.88	1.60	5°43'	0.73	3671	918			
	182	50	56		1.55	1.41	4°48'	0.69	4086	1021			
	178	60	47		1.42	1.14	4°8'	0.61	4338	1084			
	171	80	35		1.01	1.16	3°15'	0.62	5090	1100			
163	100	28		0.83	1.03	2°40'	0.57	5581	1100				
ET080	216	7.5	373	2800	9.37	4.75	21°48'	0.90	2446	611	11	186	ET06
	205	10	280		6.66	5.13	20°36'	0.90	2368	592			
	183	13.25	211		4.63	3.96	20°40'	0.87	2901	725			
	244	15	187		5.56	3.50	11°18'	0.86	2570	642			
	222	20	140		4.07	2.47	10°39'	0.80	3021	755			
	202	26.5	106		2.87	2.23	10°41'	0.78	3763	941			
	261	30	93		3.25	2.29	5°42'	0.78	3428	857			
	229	40	70		2.33	1.77	5°22'	0.72	3869	967			
	208	53	53		1.62	1.70	5°23'	0.71	4219	1055			
	246	62	45		1.67	1.58	3°13'	0.69	4034	1009			
	165	82	34		0.95	1.31	3°16'	0.62	4601	1100			
	119	110	25		0.53	1.23	3°11'	0.60	5504	1100			
ET100	377	7.5	386	2800	16.18	7.97	21°48'	0.91	3090	773	31,7	190	ET07
	348	10	280		11.46	7.14	21°48'	0.89	3113	778			
	327	13	215		8.36	6.22	20°36'	0.88	3960	990			
	425	15	193		9.45	6.44	11°18'	0.88	3525	881			
	391	20	140		6.59	5.76	11°18'	0.87	3549	887			
	353	26	108		4.81	4.38	10°39'	0.83	4388	1097			
	454	30	97		5.45	3.88	5°42'	0.81	3850	963			
	416	40	70		4.01	3.15	5°42'	0.76	4462	1115			
	363	52	54		2.97	2.45	5°22'	0.69	4744	1186			
	421	63	45		2.73	2.61	3°21'	0.71	4862	1215			
	352	82	34		1.79	2.53	3°13'	0.70	5254	1300			
	215	107	26		0.96	1.96	3°16'	0.61	5521	1300			
ET125	678	7.25	386	2800	29.46	16.20	21°48'	0.93	3101	775	62,2	194	ET08
	627	10	280		20.2	12.11	21°48'	0.91	4234	1059			
	574	13	215		14.51	10.90	21°48'	0.89	4851	1213			
	764	14.5	193		17.54	9.91	11°18'	0.88	3573	893			
	705	20	140		11.74	9.79	11°18'	0.88	4807	1202			
	644	26	108		8.47	8.41	11°18'	0.86	6208	1552			
	817	29	97		10.24	5.89	5°42'	0.81	4768	1192			
	751	40	70		6.79	5.9	5°42'	0.81	5872	1468			
	684	52	54		4.77	5.9	5°42'	0.81	6596	1649			
	760	62	45		5.04	4.00	3°24'	0.71	6244	1561			
	689	83	34		3.45	3.97	3°22'	0.71	7051	1763			
	459	107	26		1.79	3.85	3°13'	0.70	7783	1800			



# E Serisi Motorsuz Güç Devir Sayfaları

## E Series Gear Units Performance Tables

### E Serien Getriebe Leistung und Drehzahlübersicht

**1400**

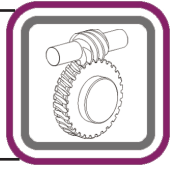

Tipi Type Typ	Anma Momenti	Çevrim Oranı	Çıkış Devri	Giriş Devri	Güç Pe/Pt [kW] (Servis Faktörü fs=1,0 için)Pe=Mekanik Güç / Pt=Termik Güç				Güv. Rad.Yük Çıkış	Güv.Rad.Yük Giriş	Ağırlık	Ölçü Sayfası	Fiyat Kodu
	Nominal Torques	Ratio	Output speeds	Input Speeds	Power Pe/Pt [kW] (For Service Factor fs=1,0) Pe=Mechanical Power / Pt=Thermal Power				Per.O.Loads (Output)	Per.O.Loads (Input)	Weight	Dim. Page	Price Ref.
	Nenn-drehmomente	Übersetzung	Abtriebs-drehzahl	Antriebs-drehzahl	Leistung Pe/Pt [kW] (Bei Betriebsfaktor fs=1,0) Pe=Mechanische Leistung / Pt=Thermische Leistung				Zul.Querkräfte (Abtrieb)	Zul.Querkräfte (Antrieb)	Gewicht	Maße Seite	Preis Num.
	Ma [Nm]	i	n2 [rpm]	n1 [rpm]	Pe [kW]	Pt [kW]	γ	η	Fqam [N]	Fqem [N]	[kg]		
<b>E040-030</b>	<b>60</b>	84	17	<b>1400</b>	0,17	-	14°02'	0,62	3400	205	4,9	198	ET09
	<b>67</b>	116	12		0,14	-	10°00'	0,59	3400	205			
	<b>64</b>	136	10		0,12	-	8°07'	0,56	3400	205			
	<b>71</b>	168	8,3		0,13	-	7°07'	0,48	3400	205			
	<b>74</b>	200	7,0		0,11	-	5°35'	0,50	3400	205			
	<b>63</b>	232	6,0		0,10	-	5°02'	0,41	3400	205			
	<b>61</b>	272	5,1		0,09	-	4°05'	0,38	3400	205			
	<b>61</b>	336	4,2		0,07	-	3°22'	0,36	3400	205			
	<b>54</b>	400	3,5		0,06	-	3°12'	0,34	3400	205			
	<b>65</b>	480	2,9		0,06	-	2°45'	0,32	3400	205			
	<b>40</b>	544	2,6		0,04	-	4°05'	0,31	3400	205			
	<b>50</b>	672	2,1		0,04	-	3°22'	0,30	3400	205			
	<b>60</b>	800	1,8		0,04	-	3°12'	0,29	3400	205			
	<b>36</b>	960	1,5		0,02	-	2°45'	0,26	3400	205			
	<b>22</b>	1088	1,3		0,02	-	4°05'	0,17	3400	205			
	<b>25</b>	1344	1,0		0,02	-	3°22'	0,17	3400	205			
	<b>26</b>	1600	0,88		0,02	-	3°12'	0,16	3400	205			
	<b>28</b>	1920	0,73		0,01	-	2°45'	0,14	3400	205			
	<b>26</b>	2520	0,56		0,01	-	2°45'	0,14	3400	205			
	<b>25</b>	3000	0,47		0,01	-	2°45'	0,14	3400	205			
<b>30</b>	3720	0,38		0,01	-	2°45'	0,14	3400	205				
<b>ET050-030</b>	<b>89</b>	138	10	<b>1400</b>	0,17	-	10°00'	0,55	4800	205	5,7	199	ET10
	<b>94</b>	174	8,1		0,16	-	10°00'	0,50	4800	205			
	<b>89</b>	210	6,7		0,13	-	10°00'	0,47	4800	205			
	<b>94</b>	247	5,7		0,12	-	8°07'	0,45	4800	205			
	<b>90</b>	305	4,6		0,11	-	7°07'	0,38	4800	205			
	<b>92</b>	363	3,9		0,09	-	5°35'	0,40	4800	205			
	<b>99</b>	421	3,3		0,09	-	5°02'	0,38	4800	205			
	<b>104</b>	493	2,8		0,09	-	4°05'	0,35	4800	205			
	<b>80</b>	609	2,3		0,07	-	3°22'	0,26	4800	205			
	<b>71</b>	725	1,9		0,06	-	3°12'	0,25	4800	205			
	<b>85</b>	870	1,6		0,06	-	2°45'	0,23	4800	205			
	<b>61</b>	986	1,4		0,04	-	4°05'	0,26	4800	205			
	<b>52</b>	1218	1,2		0,04	-	3°22'	0,17	4800	205			
	<b>61</b>	1450	1,0		0,04	-	3°12'	0,16	4800	205			
	<b>53</b>	1740	0,80		0,03	-	2°45'	0,15	4800	205			
	<b>67</b>	2280	0,61		0,03	-	2°45'	0,14	4800	205			
	<b>53</b>	3000	0,47		0,02	-	2°45'	0,13	4800	205			
	<b>49</b>	3720	0,38		0,02	-	2°45'	0,10	4800	205			
	<b>65</b>	4980	0,28		0,02	-	2°45'	0,10	4800	205			
	<b>ET063-030</b>	<b>147</b>	210,25	6,7	<b>1400</b>	0,22	-	5°22'	0,46	6200	205	8,0	200
<b>119</b>		304,5	4,6		0,16	-	5°22'	0,36	6200	205			
<b>126</b>		420,5	3,3		0,13	-	5°22'	0,33	6200	205			
<b>133</b>		493	2,8		0,12	-	5°22'	0,32	6200	205			
<b>128</b>		609	2,3		0,11	-	5°22'	0,27	6200	205			
<b>131</b>		725	1,9		0,09	-	5°22'	0,29	6200	205			
<b>126</b>		841	1,7		0,08	-	5°02'	0,27	6200	205			
<b>118</b>		986	1,4		0,07	-	4°05'	0,25	6200	205			
<b>146</b>		1218	1,2		0,07	-	3°22'	0,24	6200	205			
<b>92</b>		1450	0,97		0,06	-	3°12'	0,16	6200	205			
<b>110</b>		1740	0,80		0,06	-	2°45'	0,15	6200	205			
<b>99</b>		2340	0,60		0,04	-	2°45'	0,15	6200	205			
<b>90</b>		3060	0,46		0,03	-	2°45'	0,14	6200	205			
<b>72</b>		3660	0,38		0,03	-	2°45'	0,10	6200	205			
<b>64</b>		4920	0,28		0,02	-	2°45'	0,10	6200	205			



# E Serisi Motorsuz Güç Devir Sayfaları

## E Series Gear Units Performance Tables

### E Serien Getriebe Leistung und Drehzahlübersicht

1400

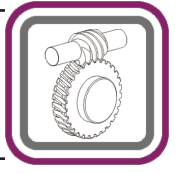

Tipi	Anma Momenti	Çevrim Oranı	Çıkış Devri	Giriş Devri	Güç Pe/Pt [kW] (Servis Faktörü fs=1,0 için)Pe=Mekanik Güç / Pt=Termik Güç				Güv. Rad.Yük Çıkış	Güv.Rad.Yük Giriş	Ağırlık	Ölçü Sayfası	Fiyat Kodu
	Nominal Torques	Ratio	Output speeds	Input Speeds	Power Pe/Pt [kW] (For Service Factor fs=1,0) Pe=Mechanical Power / Pt=Thermal Power				Per.O.Loads (Output)	Per.O.Loads (Input)	Weight	Dim. Page	Price Ref.
	Nenn-drehmomente	Übersetzung	Abtriebs-drehzahl	Antriebs-drehzahl	Leistung Pe/Pt [kW] (Bei Betriebsfaktor fs=1,0) Pe=Mechanische Leistung / Pt=Thermische Leistung				Zul.Querkräfte (Abtrieb)	Zul.Querkräfte (Antrieb)	Gewicht	Maße Seite	Preis Num.
	Ma [Nm]	i	n2 [rpm]	n1 [rpm]	Pe [kW]	Pt [kW]	γ	η	Fqam [N]	Fqem [N]	[kg]		
ET075-040	255	180	7,8	1400	0,38	-	13°52'	0,55	7000	360	12	201	ET12
	263	240	5,8		0,30	-	13°52'	0,54	7000	360			
	274	315	4,4		0,25	-	10°00'	0,52	7000	360			
	274	375	3,7		0,23	-	8°07'	0,48	7000	360			
	285	480	2,9		0,20	-	7°07'	0,44	7000	360			
	288	630	2,2		0,15	-	5°02'	0,44	7000	360			
	221	750	1,9		0,15	-	4°05'	0,30	7000	360			
	240	930	1,5		0,13	-	3°22'	0,30	7000	360			
	219	1260	1,1		0,08	-	5°02'	0,33	7000	360			
	156	1500	0,93		0,07	-	4°05'	0,21	7000	360			
	193	1860	0,75		0,07	-	3°22'	0,21	7000	360			
	167	2480	0,56		0,05	-	3°22'	0,18	7000	360			
	123	3100	0,45		0,04	-	3°22'	0,16	7000	360			
	127	3720	0,38		0,04	-	3°22'	0,14	7000	360			
	112	4960	0,28		0,03	-	3°14'	0,11	7000	360			
	119	6200	0,23		0,03	-	2°40'	0,09	7000	360			
ET080-040	325	180	7,8	1400	0,51	-	11°18'	0,52	7400	360	14	202	ET13
	340	240	5,8		0,41	-	11°18'	0,50	7400	360			
	352	315	4,4		0,34	-	10°00'	0,49	7400	360			
	355	375	3,7		0,31	-	8°07'	0,45	7400	360			
	351	480	2,9		0,26	-	7°07'	0,41	7400	360			
	352	630	2,2		0,22	-	5°02'	0,38	7400	360			
	355	750	1,9		0,20	-	4°05'	0,35	7400	360			
	285	930	1,5		0,16	-	3°22'	0,28	7400	360			
	277	1260	1,1		0,12	-	5°02'	0,28	7400	360			
	282	1500	0,93		0,11	-	4°05'	0,25	7400	360			
	209	1860	0,75		0,09	-	3°22'	0,18	7400	360			
	157	2480	0,56		0,05	-	3°22'	0,17	7400	360			
	139	3286	0,43		0,04	-	3°22'	0,17	7400	360			
	105	3844	0,36		0,04	-	3°13'	0,11	7400	360			
	114	5084	0,28		0,03	-	3°16'	0,11	7400	360			
	ET100-050	636	180	7,8	1400	0,88	-	11°18'	0,59	8200	500	36,8	203
580		217,5	6,4		0,76	-	10°41'	0,52	8200	500			
600		285	4,9		0,65	-	10°07'	0,47	8200	500			
612		375	3,7		0,50	-	8°44'	0,48	8200	500			
617		435	3,0		0,46	-	5°23'	0,45	8200	500			
637		570	2,5		0,39	-	5°06'	0,42	8200	500			
645		750	1,9		0,32	-	4°23'	0,39	8200	500			
639		930	1,5		0,28	-	3°11'	0,37	8200	500			
465		1240	1,1		0,19	-	3°11'	0,29	8200	500			
369		1612	0,87		0,12	-	3°11'	0,28	8200	500			
467		1860	0,75		0,14	-	3°11'	0,27	8200	500			
279		2480	0,56		0,09	-	3°11'	0,19	8200	500			
273		3224	0,43		0,07	-	3°11'	0,18	8200	500			
266		3906	0,36		0,07	-	3°11'	0,15	8200	500			
201		5084	0,28		0,05	-	3°11'	0,12	8200	500			
ET125-063		1164	184,88	7,6	1400	1,49	-	11°18'	0,62	13000	700	70,0	204
	1222	210,25	6,7		1,43	-	10°39'	0,60	13000	700			
	1081	282,75	5,0		1,09	-	10°41'	0,52	13000	700			
	1112	369,75	3,8		0,91	-	10°07'	0,49	13000	700			
	1102	420,5	3,3		0,85	-	5°22'	0,45	13000	700			
	1142	565,5	2,5		0,68	-	5°23'	0,43	13000	700			



# E Serisi Motorsuz Güç Devir Sayfaları

## E Series Gear Units Performance Tables

### E Serien Getriebe Leistung und Drehzahlübersicht

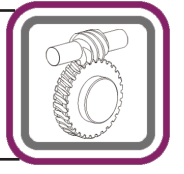
**1400**

Tipi Type Typ	Anma Momenti Nominal Torques Nenn-drehmomente	Çevrim Oranı Ratio Übersetzung	Çıkış Devri Output speeds Abtriebs-drehzahl	Giriş Devri Input Speeds Antriebs-drehzahl	Güç Pe/Pt [kW] (Servis Faktörü $fs=1,0$ için)Pe=Mekanik Güç / Pt=Termik Güç Power Pe/Pt [kW] (For Service Factor $fs=1,0$ ) Pe=Mechanical Power / Pt=Thermal Power Leistung Pe/Pt [kW] (Bei Betriebsfaktor $fs=1,0$ ) Pe=Mechanische Leistung / Pt=Thermische Leistung				Güv. Rad.Yük Çıkış Per.O.Loads (Output) Zul.Querkräfte (Abtrieb)	Güv.Rad.Yük Giriş Per.O.Loads (Input) Zul.Querkräfte (Antrieb)	Ağırlık Weight Gewicht	Ölçü Sayfası Dim. Page Maße Seite	Fiyat Kodu Price Ref. Preis Num.
	Ma [Nm]	i	n2 [rpm]	n1 [rpm]	Pe [kW]	Pt [kW]	$\gamma$	$\eta$	Fqam [N]	Fqem [N]	[kg]		
	<b>ET125-063</b>	<b>1144</b>	739,5	1,9	<b>1400</b>	0,55	-	5,06	0,42	13000	700	70,0	204
	<b>1178</b>	884,5	1,6		0,53	-	3,16	0,37	13000	700			
	<b>1175</b>	1189	1,2		0,42	-	3,11	0,35	13000	700			
	<b>783</b>	1640	0,85		0,25	-	3,11	0,28	13000	700			
	<b>727</b>	2132	0,66		0,18	-	3,11	0,28	13000	700			
	<b>895</b>	2378	0,59		0,22	-	3,11	0,25	13000	700			
	<b>517</b>	3280	0,43		0,13	-	3,11	0,18	13000	700			
	<b>480</b>	4264	0,33		0,09	-	3,11	0,18	13000	700			
	<b>364</b>	5084	0,28		0,09	-	3,11	0,12	13000	700			



# E Serisi Motorsuz Güç Devir Sayfaları

## E Series Gear Units Performance Tables

### E Serien Getriebe Leistung und Drehzahlübersicht

1400

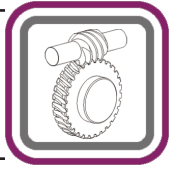

Tipi	Anma Momenti	Çevrim Oranı	Çıkış Devri	Giriş Devri	Güç Pe/Pt [kW] (Servis Faktörü fs=1,0 için)Pe=Mekanik Güç / Pt=Termik Güç				Güv. Rad.Yük Çıkış	Güv.Rad.Yük Giriş	Ağırlık	Ölçü Sayfası	Fiyat Kodu
	Nominal Torques	Ratio	Output speeds	Input Speeds	Power Pe/Pt [kW] (For Service Factor fs=1,0) Pe=Mechanical Power / Pt=Thermal Power				Per.O.Loads (Output)	Per.O.Loads (Input)	Weight	Dim. Page	Price Ref.
	Nenn-drehmomente	Übersetzung	Abtriebs-drehzahl	Antriebs-drehzahl	Leistung Pe/Pt [kW] (Bei Betriebsfaktor fs=1,0) Pe=Mechanische Leistung / Pt=Thermische Leistung				Zul.Querkräfte (Abtrieb)	Zul.Querkräfte (Antrieb)	Gewicht	Maße Seite	Preis Num.
	Ma [Nm]	i	n2 [rpm]	n1 [rpm]	Pe [kW]	Pt [kW]	γ	η	Fqam [N]	Fqem [N]	[kg]		
EN063-NT01	51	600	2,3	1400	0,04	-	2,12	0,31	6200	350	9,4	206	ET17
	92	492	2,9		0,07	-	3,11	0,39	6200	350			
	100	366	3,8		0,10	-	3,16	0,40	6200	350			
	106	306	4,6		0,10	-	5,06	0,51	6200	350			
	125	234	5,6		0,15	-	5,23	0,52	6200	350			
	138	174	8,1		0,22	-	5,22	0,53	6200	350			
	131	153	9,2		0,19	-	10,07	0,66	6200	350			
	149	117	12		0,27	-	10,41	0,69	6200	350			
EN075-NT11	54	745	1,88	1400	0,03	-	2,40	0,35	7000	450	13,5	207	ET18
	82	596	2,35		0,05	-	3,14	0,40	7000	450			
	137	447	3,13		0,10	-	4,08	0,45	7000	450			
	194	372,5	3,76		0,15	-	4,48	0,50	7000	450			
	212	298	4,70		0,19	-	5,42	0,54	7000	450			
	234	223,5	6,26		0,27	-	7,02	0,58	7000	450			
	243	186,25	7,52		0,30	-	9,32	0,65	7000	450			
	256	149	9,40		0,37	-	11,18	0,69	7000	450			
	265	11,75	12,53		0,48	-	13,52	0,73	7000	450			
	EN080-NT11	50	819,5	1,7	1400	0,03	-	3,11	0,30	7400			
100		610,9	2,3		0,06	-	3,16	0,40	7400	450			
151		461,9	3,0		0,12	-	3,13	0,40	7400	450			
224		394,85	3,6		0,16	-	5,23	0,52	7400	450			
259		298	4,7		0,24	-	5,22	0,53	7400	450			
296		223,5	6,3		0,36	-	5,42	0,54	7400	450			
280		197,43	7,1		0,31	-	10,39	0,67	7400	450			
318		149	9,4		0,46	-	11,18	0,68	7400	450			
347		111,75	13		0,65	-	11,18	0,70	7400	450			
EN100-NT11		127	797,15	1,8	1400	0,06	-	3,16	0,39	7400	450	36,2	209
	200	610,9	2,3		0,12	-	3,13	0,40	7400	450			
	309	469,35	3,0		0,23	-	3,21	0,42	7400	450			
	412	387,4	3,6		0,30	-	5,22	0,52	7400	450			
	461	298	4,7		0,42	-	5,40	0,54	7400	450			
	511	223,5	6,3		0,61	-	5,42	0,55	7400	450			
	485	193,7	7,2		0,54	-	10,39	0,68	7400	450			
	579	149	9,4		0,77	-	11,18	0,74	7400	450			
EN125-NT21	301	516,81	2,7	1400	0,19	-	3,13	0,45	13000	500	68,5	210	ET20
	476	400,89	3,5		0,37	-	3,22	0,47	13000	500			
	735	299,46	4,7		0,72	-	5,42	0,50	13000	500			
	638	251,16	5,6		0,73	-	5,42	0,51	13000	500			
	891	193,2	7,3		1,09	-	5,42	0,62	13000	500			
	1027	140,07	10		1,68	-	11,18	0,64	13000	500			
	868	125,58	11		1,37	-	11,18	0,74	13000	500			

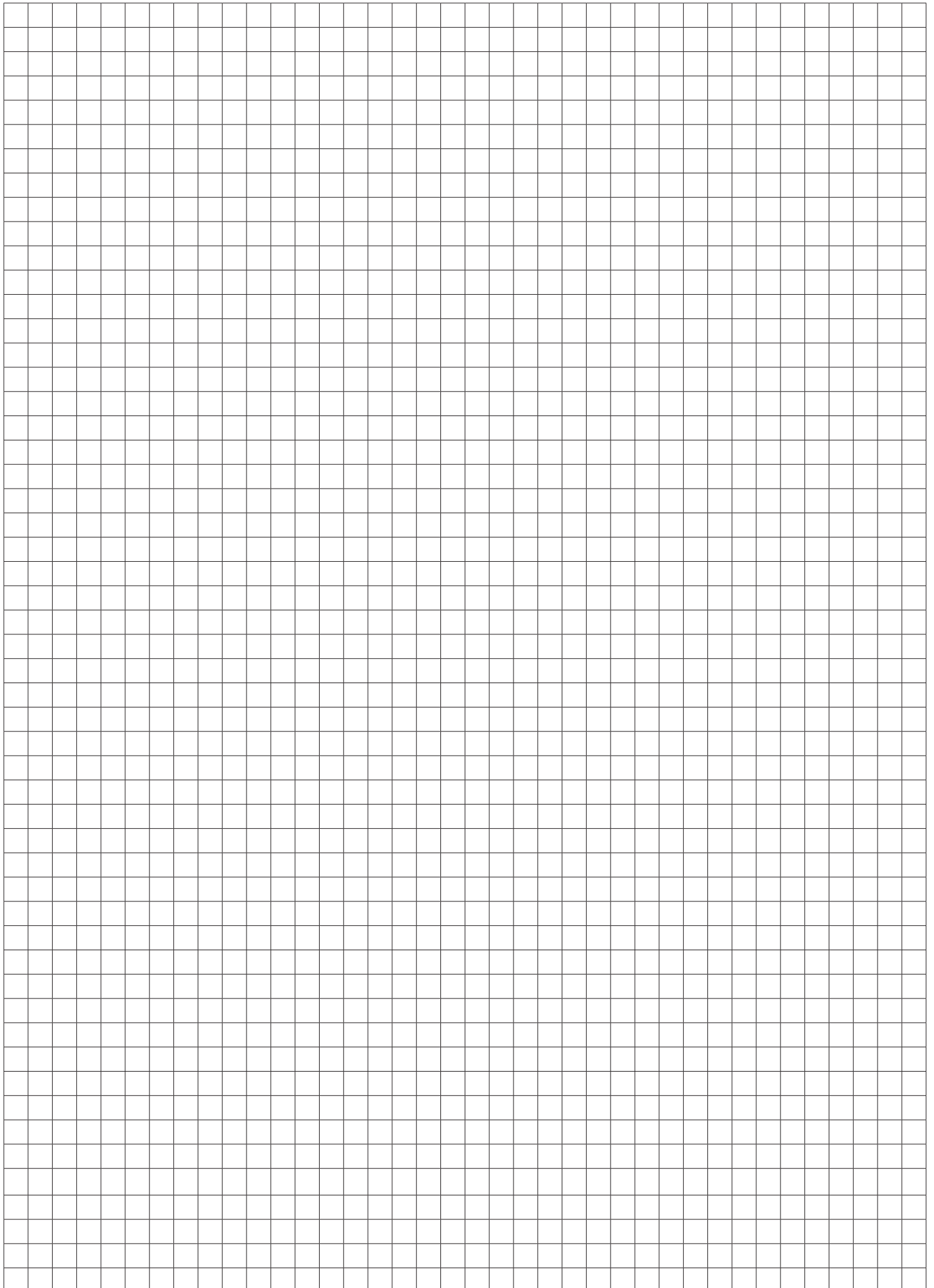

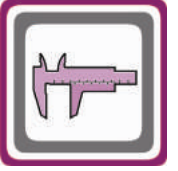
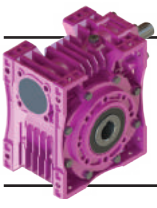

# Ölçü Tabloları

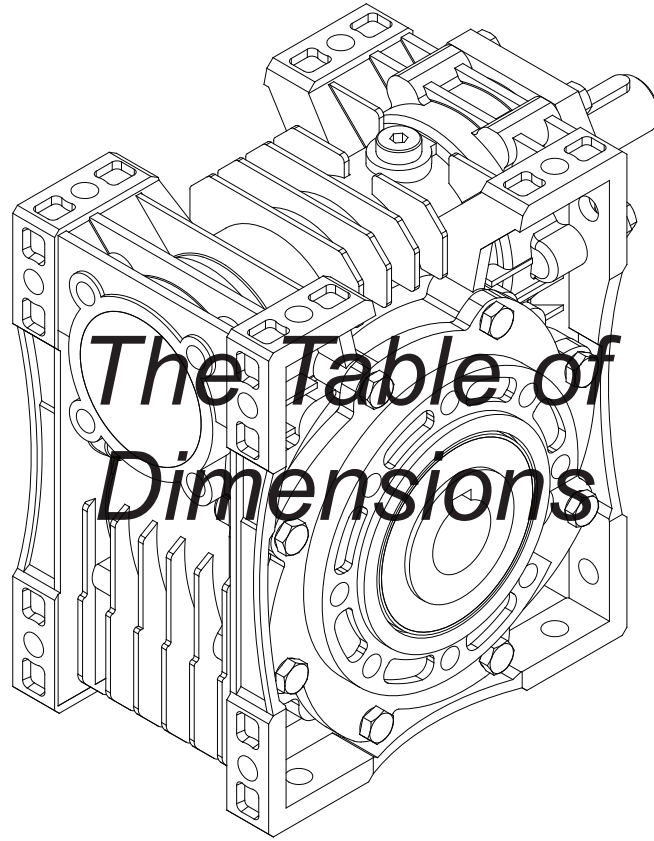

Abmessungs-tabellen



# Ölçü Sayfaları

## Dimension Pages

### Abmessungsseiten

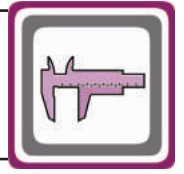

-Mil ucu çekirme deliği DIN 332 sayfa 2 / Tapped center hole to DIN 332, sheet 2 / Zentrierung mit Gewinde DIN 332, Blatt 2

#### ET030.00

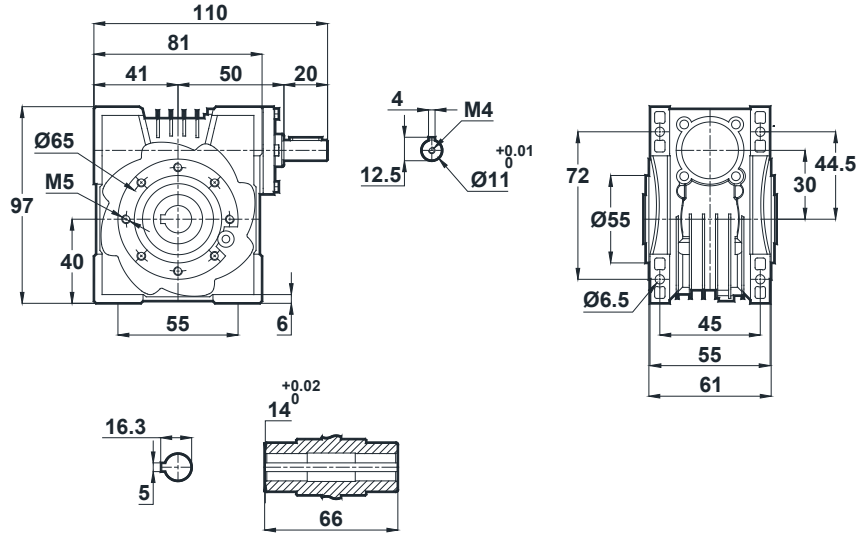
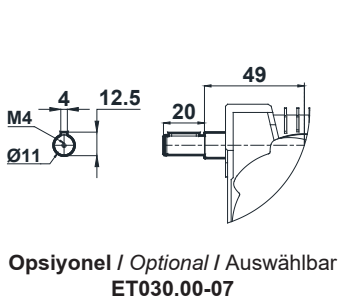

#### ET030.01

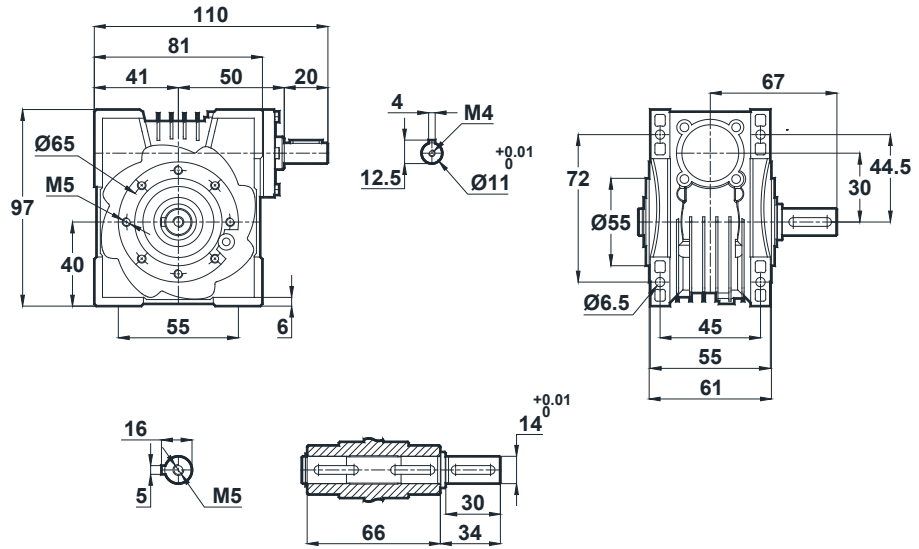
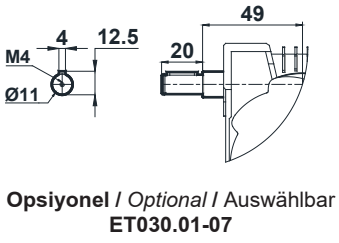







# Ölçü Sayfaları

## Dimension Pages

### Abmessungsseiten

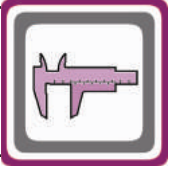

-Mil ucu çekirme deliği DIN 332 sayfa 2 / Tapped center hole to DIN 332, sheet 2 / Zentrierung mit Gewinde DIN 332, Blatt 2

ET030.08

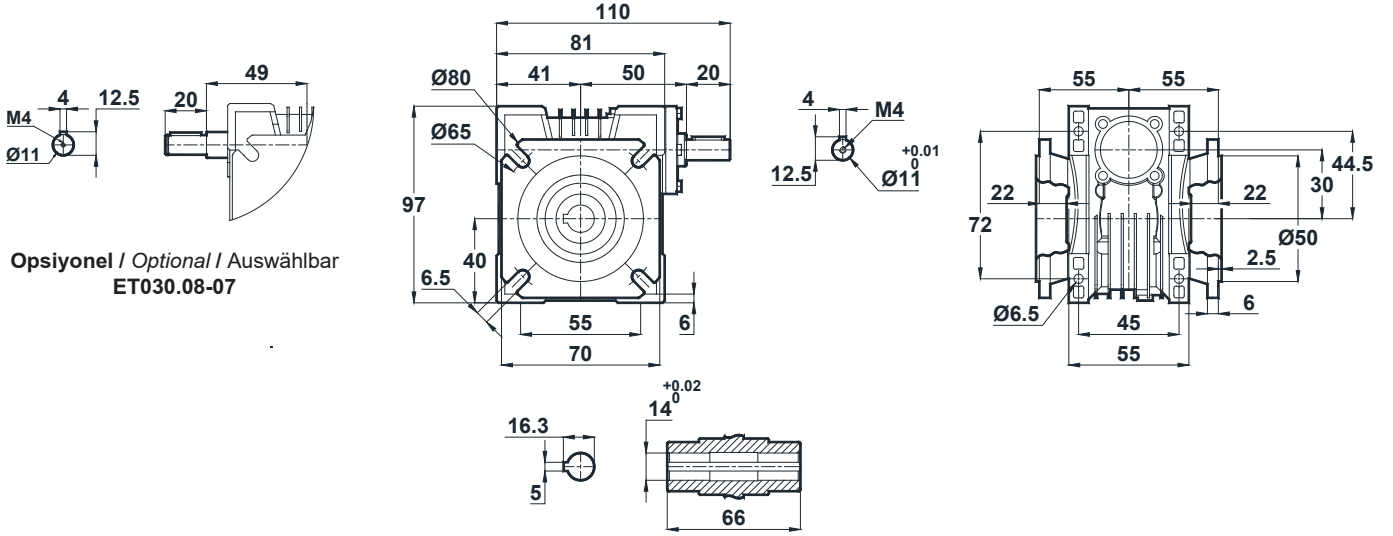



# Ölçü Sayfaları

## Dimension Pages

### Abmessungsseiten

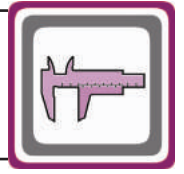

-Mil ucu çekirme deliği DIN 332 sayfa 2 / Tapped center hole to DIN 332, sheet 2 / Zentrierung mit Gewinde DIN 332, Blatt 2

#### ET040.00

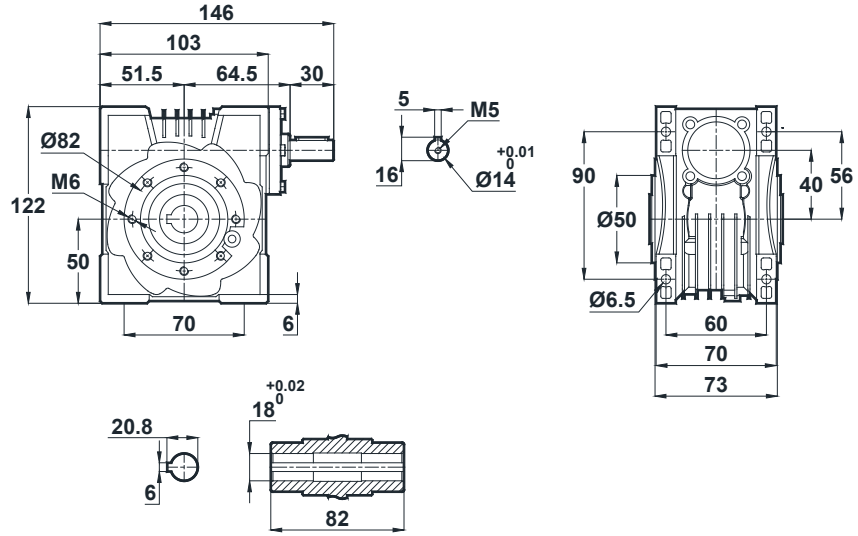
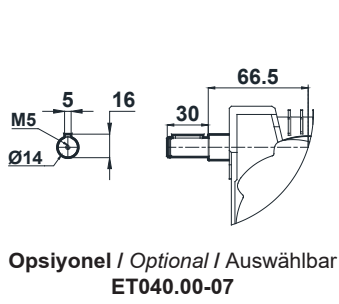

#### ET040.01

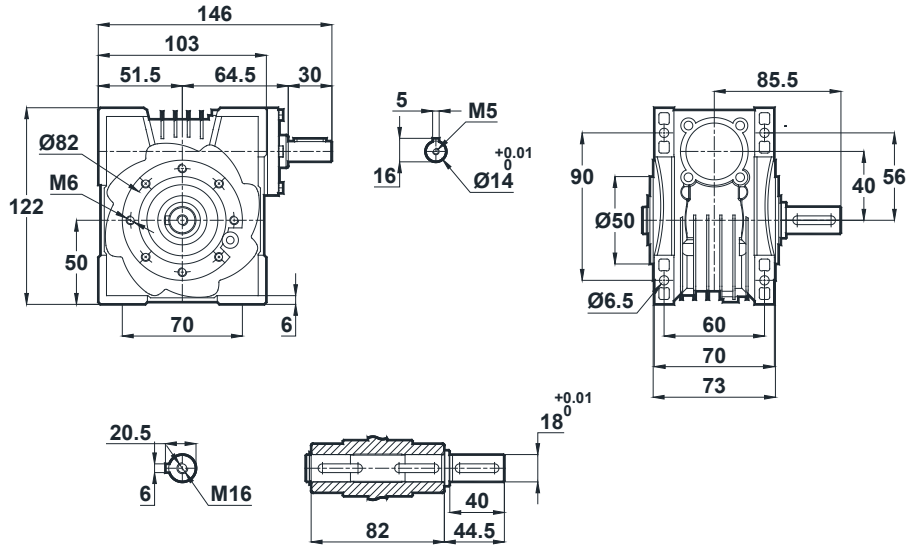
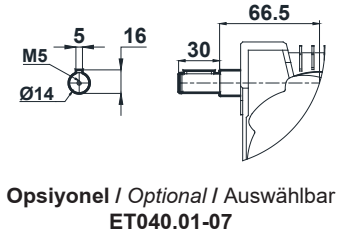



# Ölçü Sayfaları

## Dimension Pages

### Abmessungsseiten

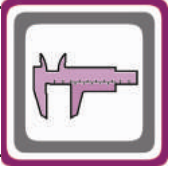

-Mil ucu çekirme deliği DIN 332 sayfa 2 / Tapped center hole to DIN 332, sheet 2 / Zentrierung mit Gewinde DIN 332, Blatt 2

#### ET040.02

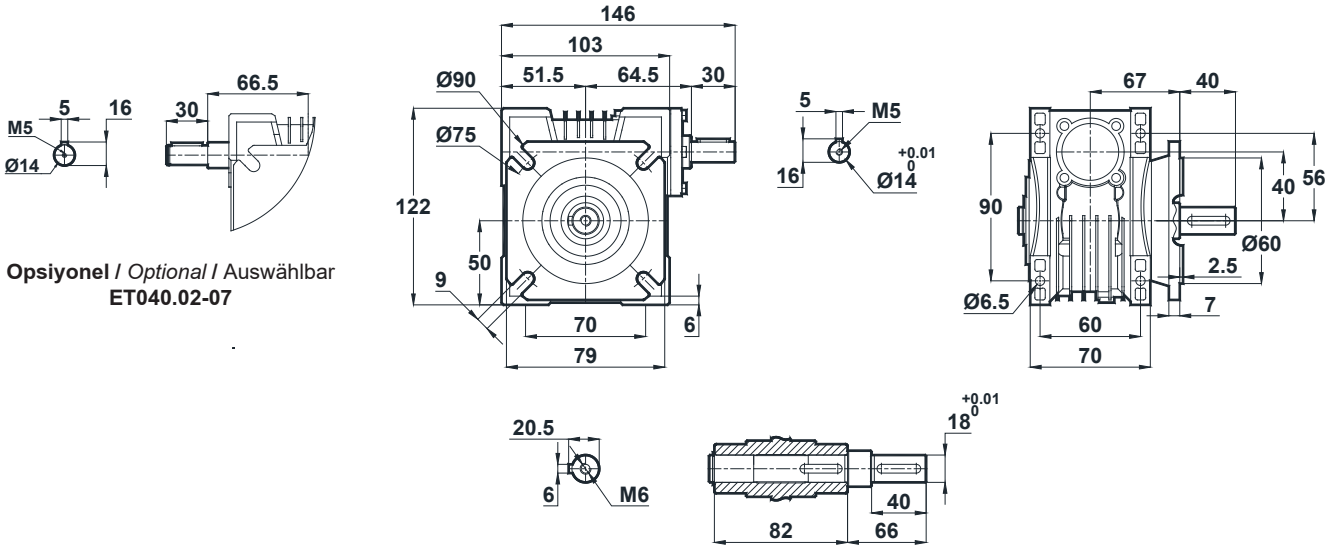

#### ET040.03

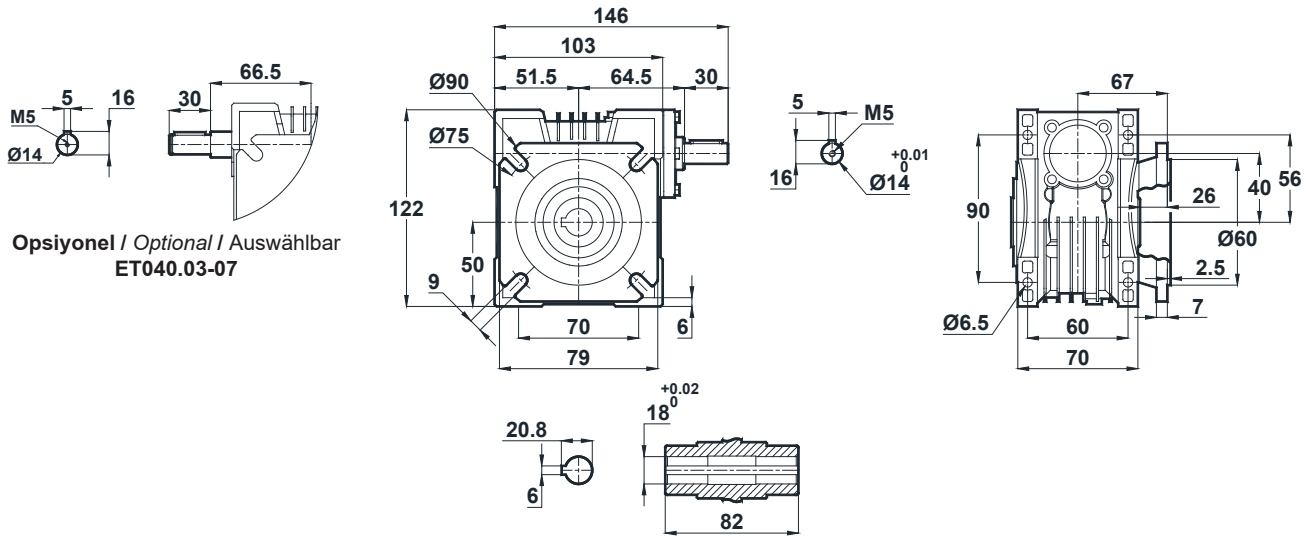



# Ölçü Sayfaları

## Dimension Pages

### Abmessungsseiten

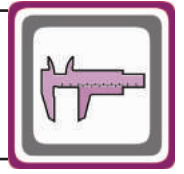

-Mil ucu çekirme deliği DIN 332 sayfa 2 / Tapped center hole to DIN 332, sheet 2 / Zentrierung mit Gewinde DIN 332, Blatt 2

#### ET040.04

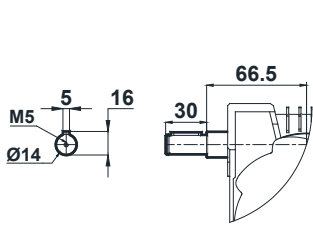

Opsiyonel / Optional / Auswählbar  
ET040.04-07

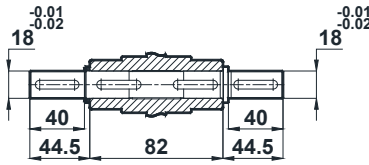
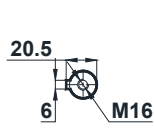
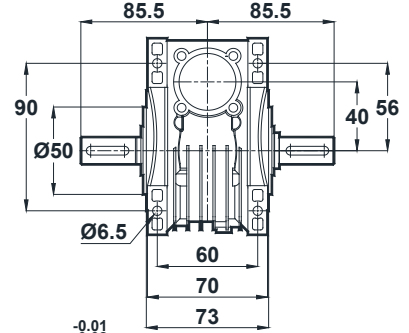
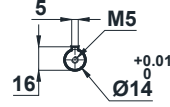
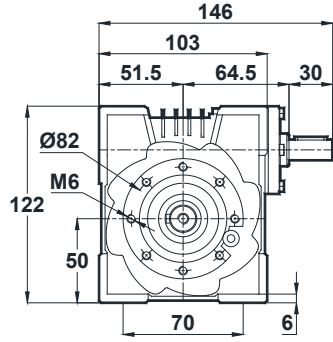

#### ET040.05

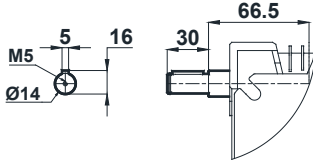

Opsiyonel / Optional / Auswählbar  
ET040.05-07

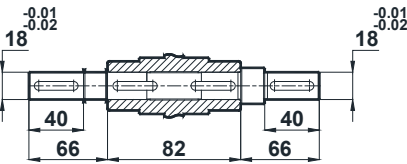
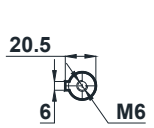
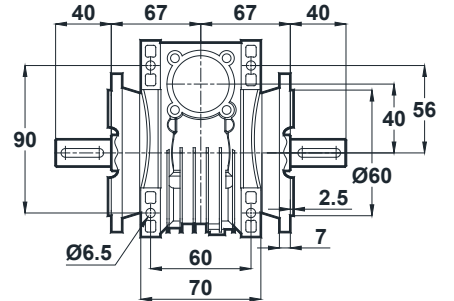
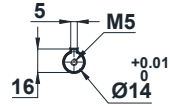
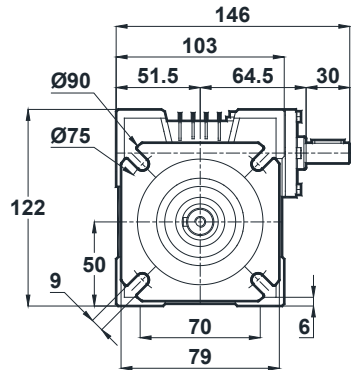



# Ölçü Sayfaları

## Dimension Pages

### Abmessungsseiten

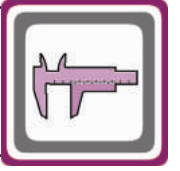

-Mil ucu çekirme deliği DIN 332 sayfa 2 / Tapped center hole to DIN 332, sheet 2 / Zentrierung mit Gewinde DIN 332, Blatt 2

ET040.08

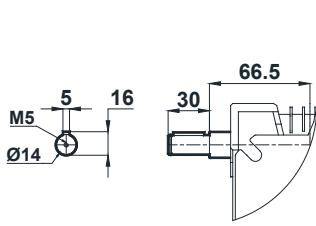

Opsiyonel / Optional / Auswählbar  
ET040.08-07

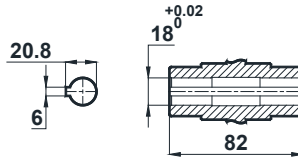
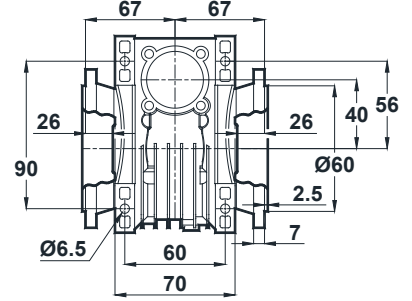
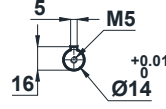
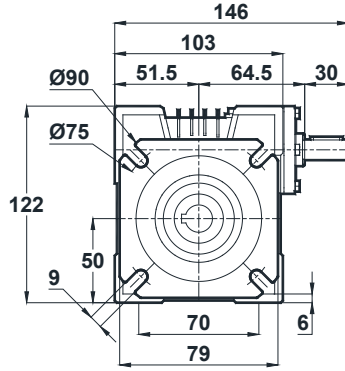



# Ölçü Sayfaları

## Dimension Pages

### Abmessungsseiten

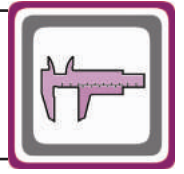

-Mil ucu çekirme deliği DIN 332 sayfa 2 / Tapped center hole to DIN 332, sheet 2 / Zentrierung mit Gewinde DIN 332, Blatt 2

#### ET050.00

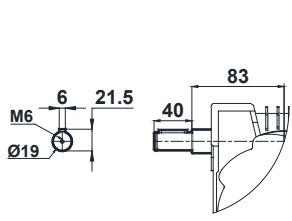

Opsiyonel / Optional / Auswählbar  
ET050.00-07

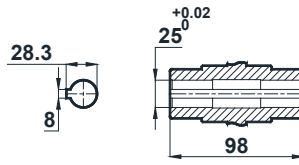
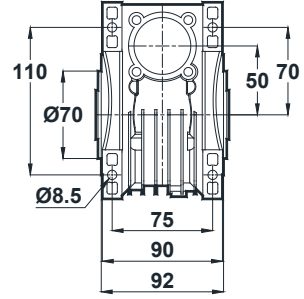
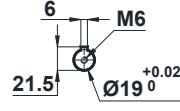
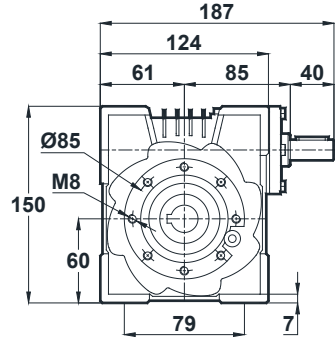

#### ET050.01

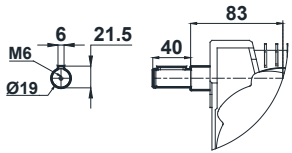

Opsiyonel / Optional / Auswählbar  
ET050.01-07

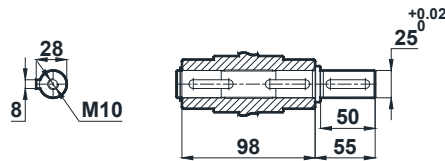
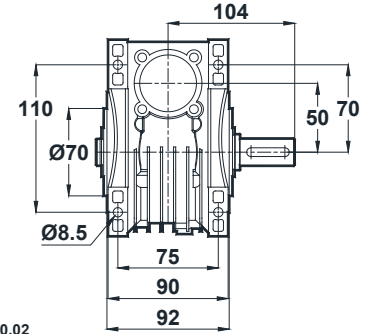
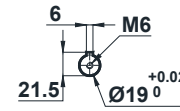
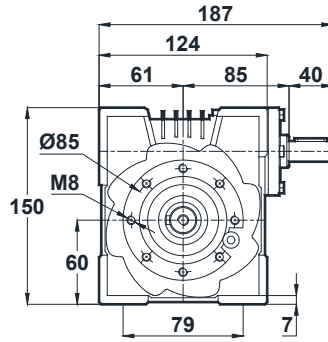



# Ölçü Sayfaları

## Dimension Pages

### Abmessungsseiten

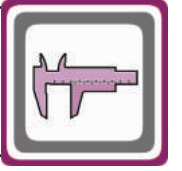

-Mil ucu çekirme deliği DIN 332 sayfa 2 / Tapped center hole to DIN 332, sheet 2 / Zentrierung mit Gewinde DIN 332, Blatt 2

#### ET050.02

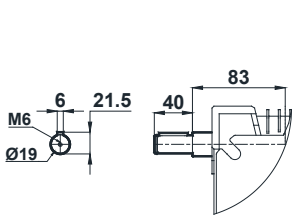

Opsiyonel / Optional / Auswählbar  
ET050.02-07

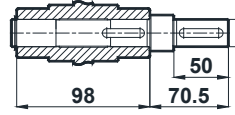
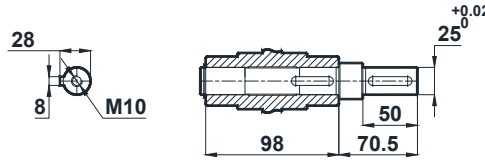
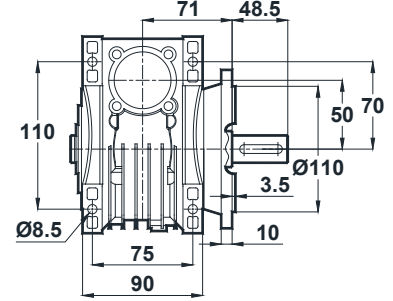
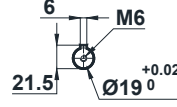
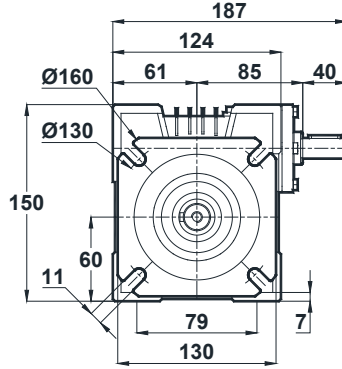

#### ET050.03

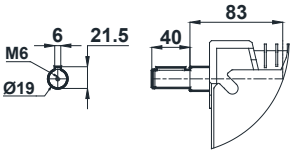

Opsiyonel / Optional / Auswählbar  
ET050.03-07

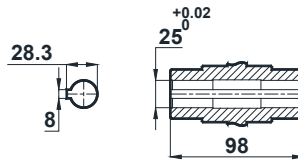
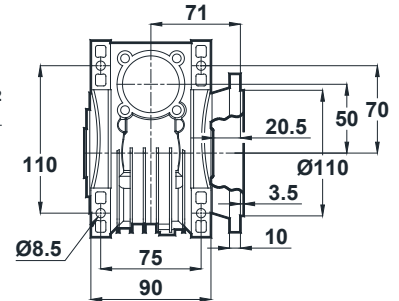
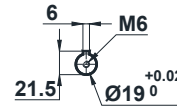
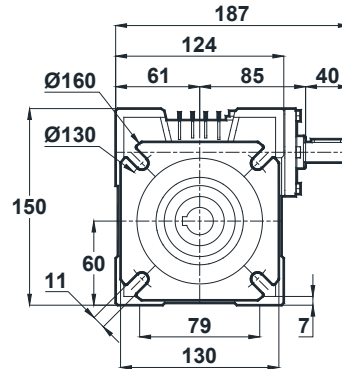



# Ölçü Sayfaları

## Dimension Pages

### Abmessungsseiten

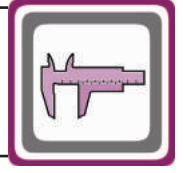

-Mil ucu çekirme deliği DIN 332 sayfa 2 / Tapped center hole to DIN 332, sheet 2 / Zentrierung mit Gewinde DIN 332, Blatt 2

#### ET050.04

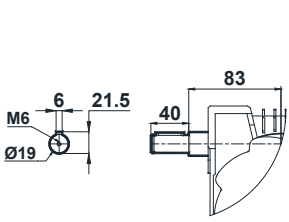

Opsiyonel / Optional / Auswählbar  
ET050.04-07

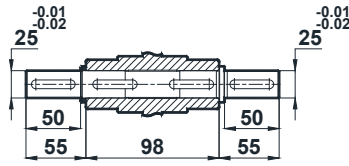
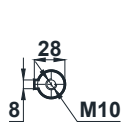
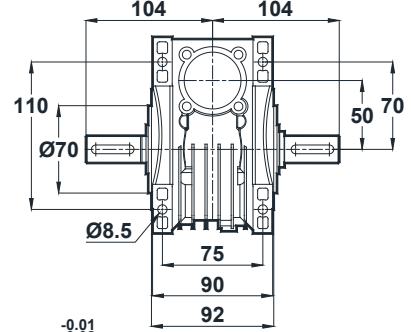
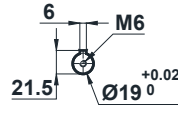
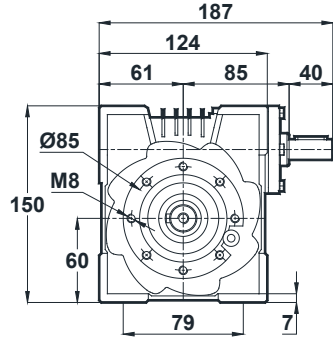

#### ET050.05

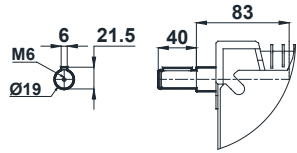

Opsiyonel / Optional / Auswählbar  
ET050.05-07

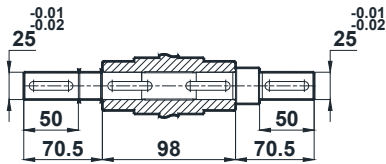
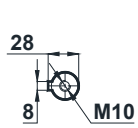
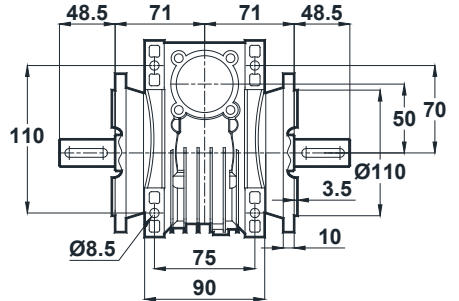
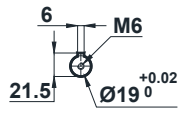
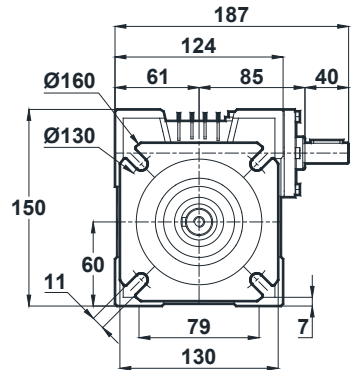



# Ölçü Sayfaları

## Dimension Pages

### Abmessungsseiten

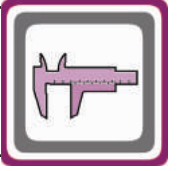

-Mil ucu çekirme deliği DIN 332 sayfa 2 / Tapped center hole to DIN 332, sheet 2 / Zentrierung mit Gewinde DIN 332, Blatt 2

ET050.08

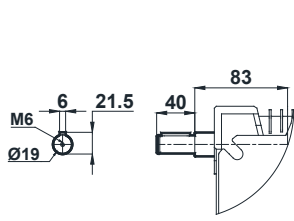

Opsiyonel / Optional / Auswählbar  
ET050.08-07

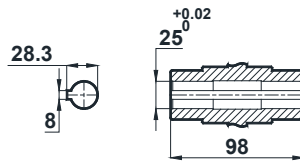
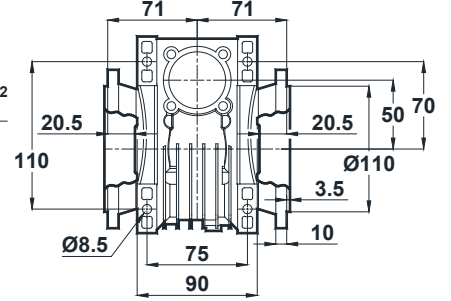
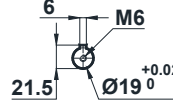
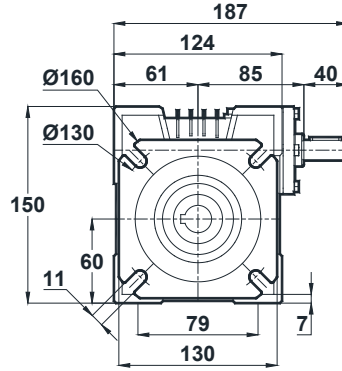



# Ölçü Sayfaları

## Dimension Pages

### Abmessungsseiten

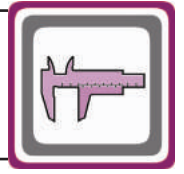

-Mil ucu çekirme deliği DIN 332 sayfa 2 / Tapped center hole to DIN 332, sheet 2 / Zentrierung mit Gewinde DIN 332, Blatt 2

#### ET063.00

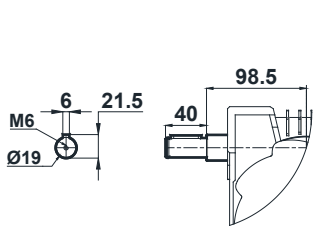

Opsiyonel / Optional / Auswählbar  
ET063.00-07

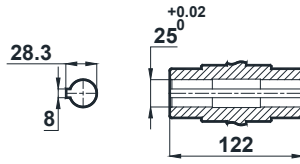
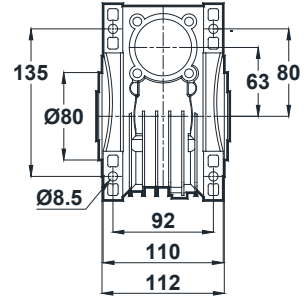
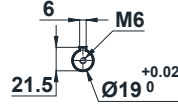
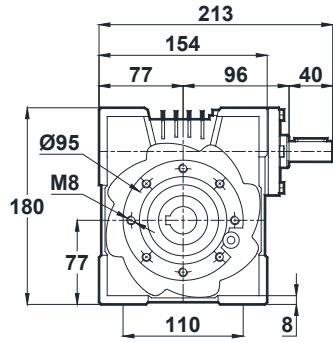

#### ET063.01

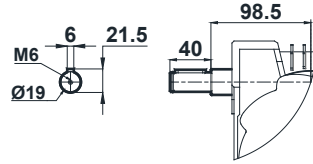

Opsiyonel / Optional / Auswählbar  
ET063.01-07

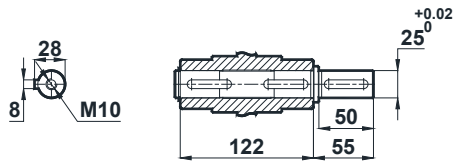
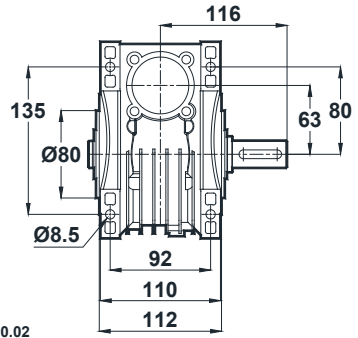
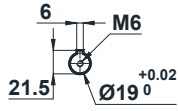
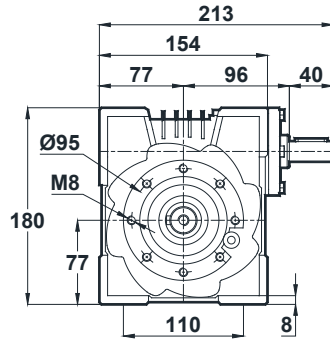



# Ölçü Sayfaları

## Dimension Pages

### Abmessungsseiten

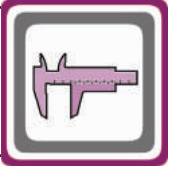

-Mil ucu çekirme deliği DIN 332 sayfa 2 / Tapped center hole to DIN 332, sheet 2 / Zentrierung mit Gewinde DIN 332, Blatt 2

#### ET063.02

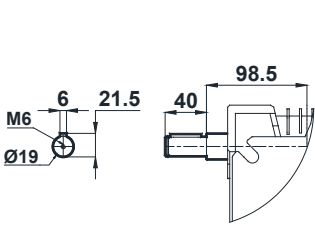

Opsiyonel / Optional / Auswählbar  
ET063.02-07

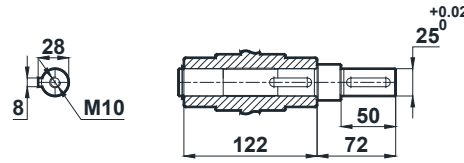
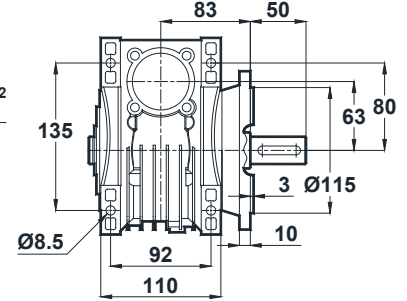
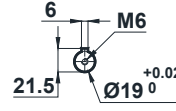
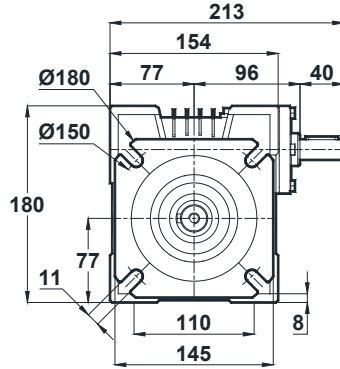

#### ET063.03

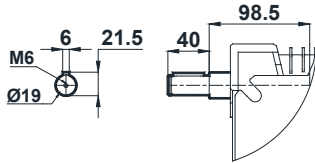

Opsiyonel / Optional / Auswählbar  
ET063.03-07

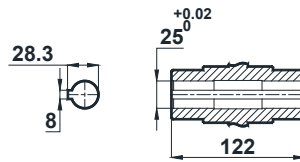
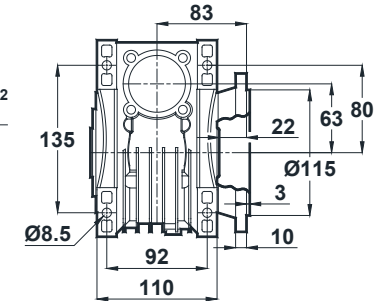
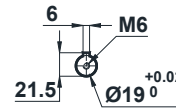
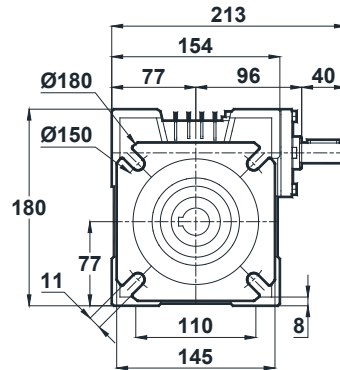



# Ölçü Sayfaları

## Dimension Pages

### Abmessungsseiten

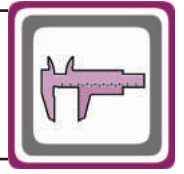

-Mil ucu çekirme deliği DIN 332 sayfa 2 / Tapped center hole to DIN 332, sheet 2 / Zentrierung mit Gewinde DIN 332, Blatt 2

#### ET063.04

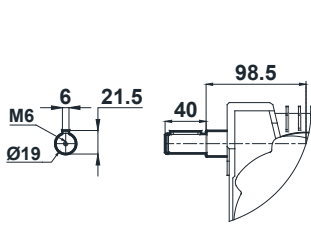

Opsiyonel / Optional / Auswählbar  
ET063.04-07

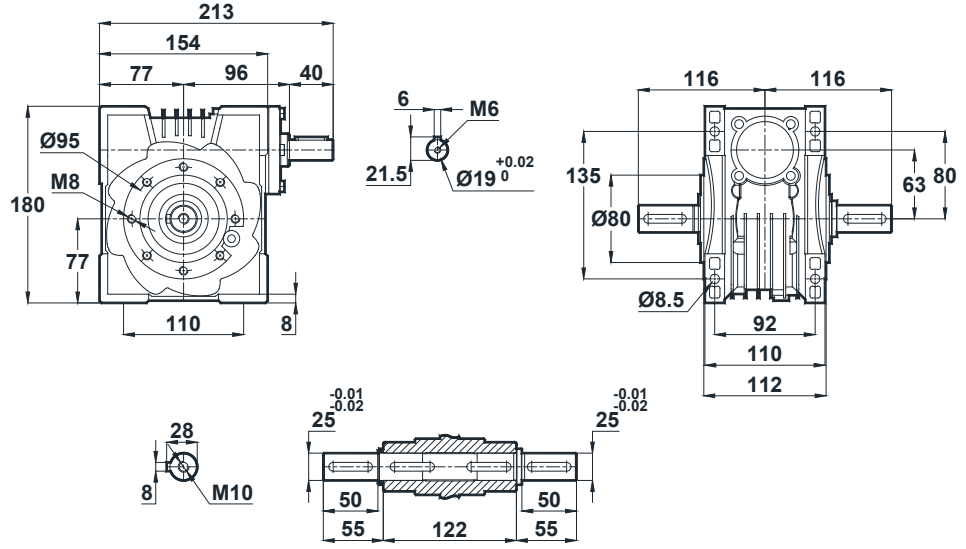

#### ET063.05

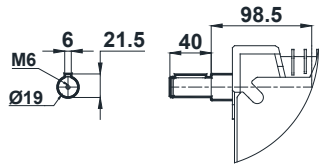

Opsiyonel / Optional / Auswählbar  
ET063.05-07

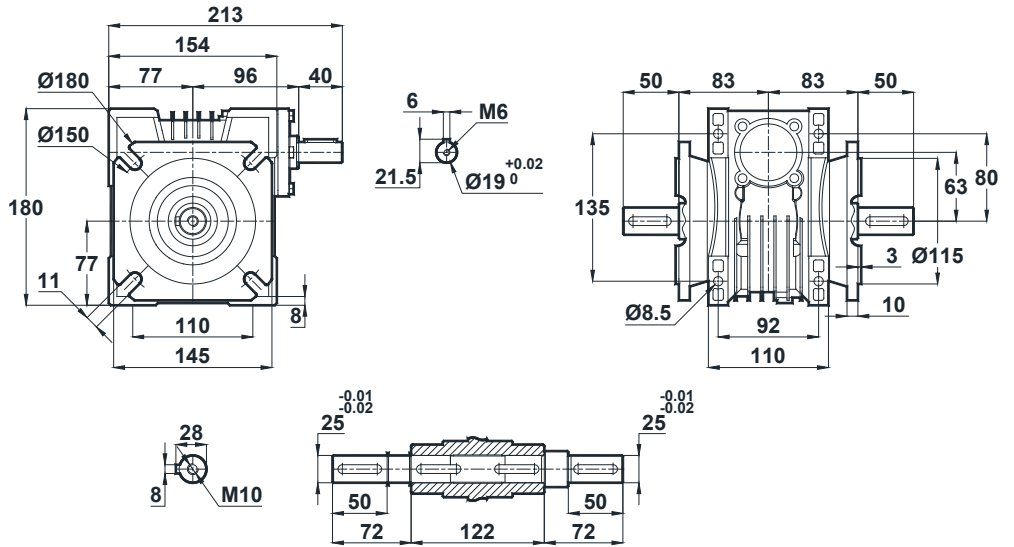



# Ölçü Sayfaları

## Dimension Pages

### Abmessungsseiten

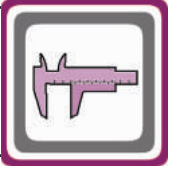

-Mil ucu çekirme deliği DIN 332 sayfa 2 / Tapped center hole to DIN 332, sheet 2 / Zentrierung mit Gewinde DIN 332, Blatt 2

ET063.08

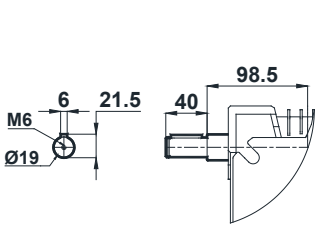

Opsiyonel / Optional / Auswählbar  
ET063.08-07

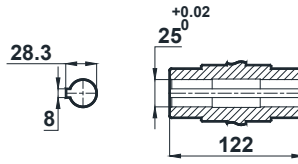
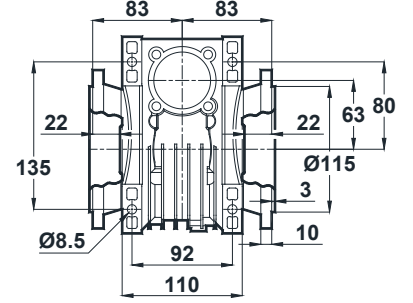
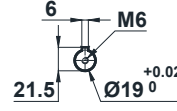
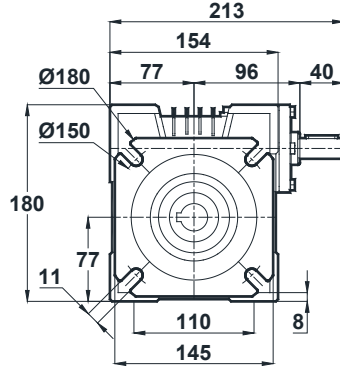



# Ölçü Sayfaları

## Dimension Pages

### Abmessungsseiten

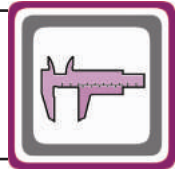

-Mil ucu çekirme deliği DIN 332 sayfa 2 / Tapped center hole to DIN 332, sheet 2 / Zentrierung mit Gewinde DIN 332, Blatt 2

#### ET075.00

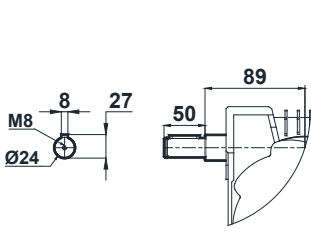

Opsiyonel / Optional / Auswählbar  
ET075.00-07

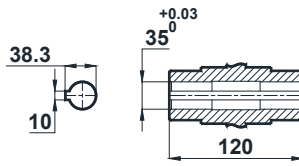
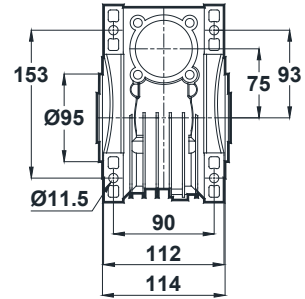
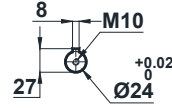
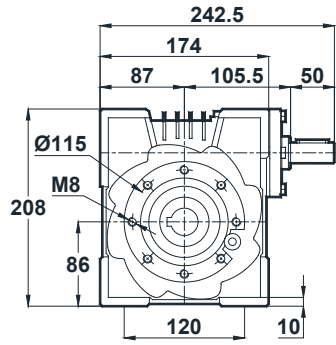

#### ET075.01

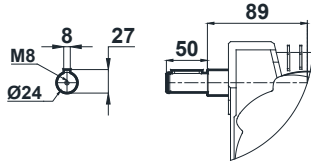

Opsiyonel / Optional / Auswählbar  
ET075.01-07

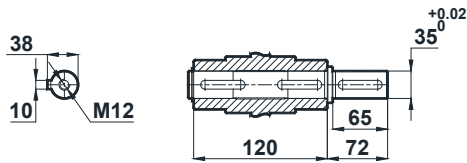
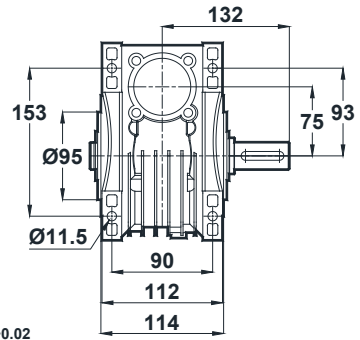
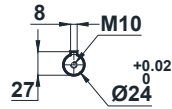
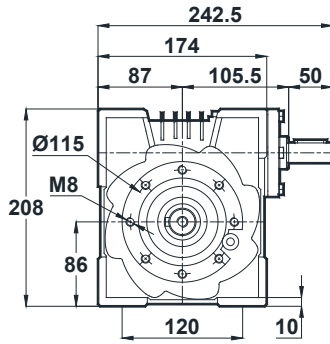



# Ölçü Sayfaları

## Dimension Pages

### Abmessungsseiten

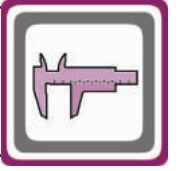

-Mil ucu çekirme deliği DIN 332 sayfa 2 / Tapped center hole to DIN 332, sheet 2 / Zentrierung mit Gewinde DIN 332, Blatt 2

#### ET075.02

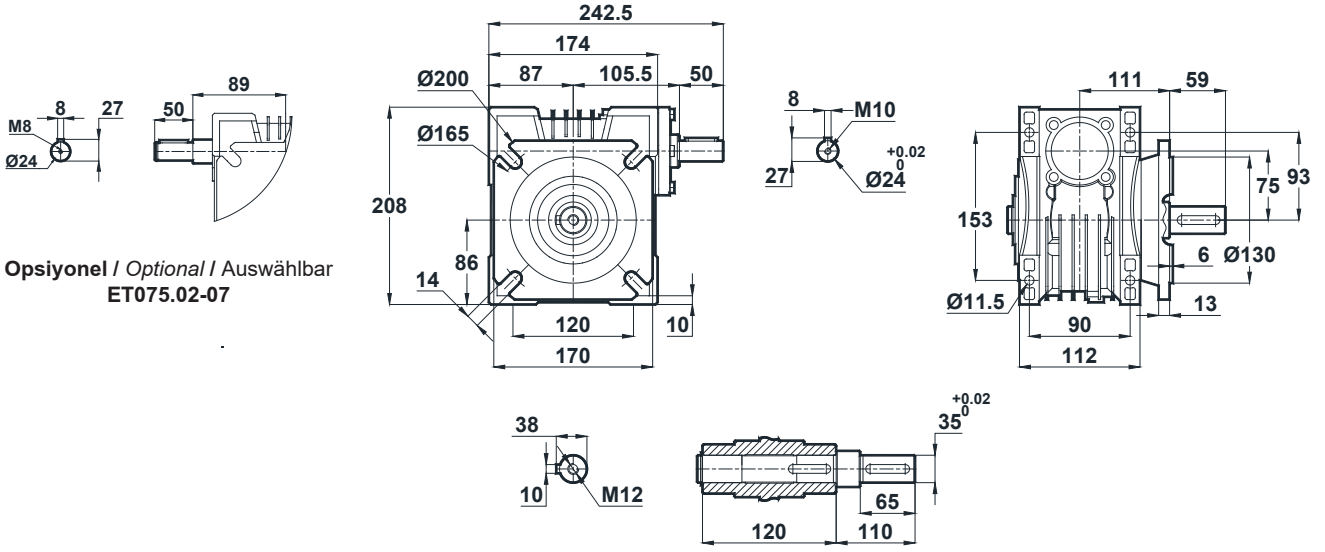

#### ET075.03

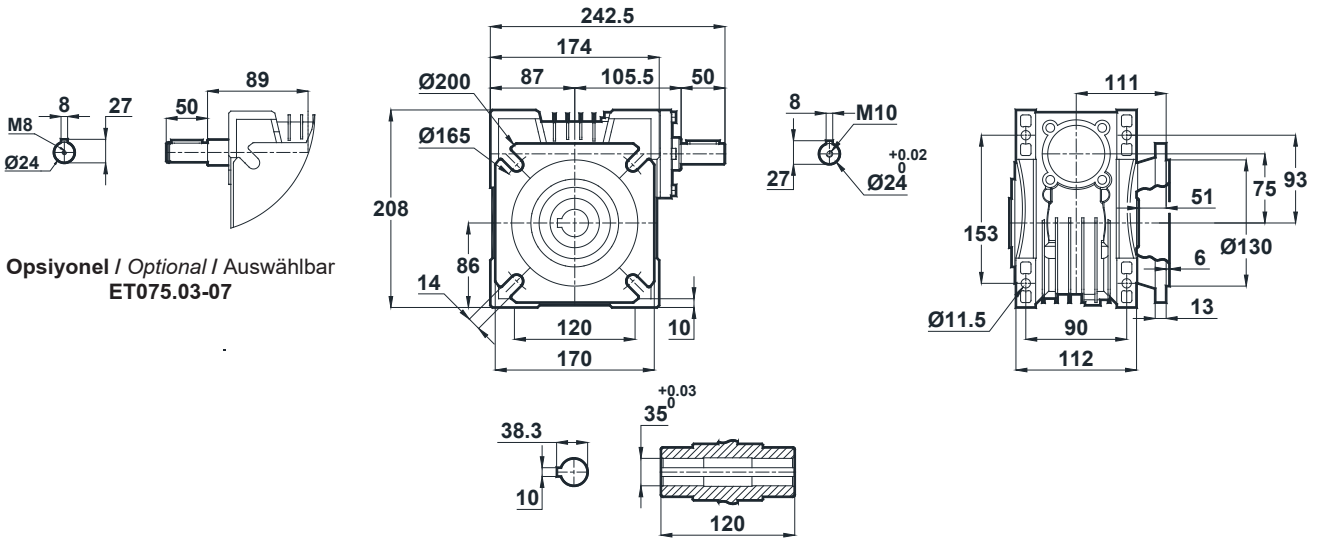



# Ölçü Sayfaları

## Dimension Pages

### Abmessungsseiten

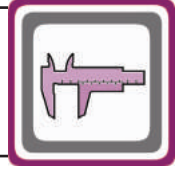

-Mil ucu çekirme deliği DIN 332 sayfa 2 / Tapped center hole to DIN 332, sheet 2 / Zentrierung mit Gewinde DIN 332, Blatt 2

#### ET075.04

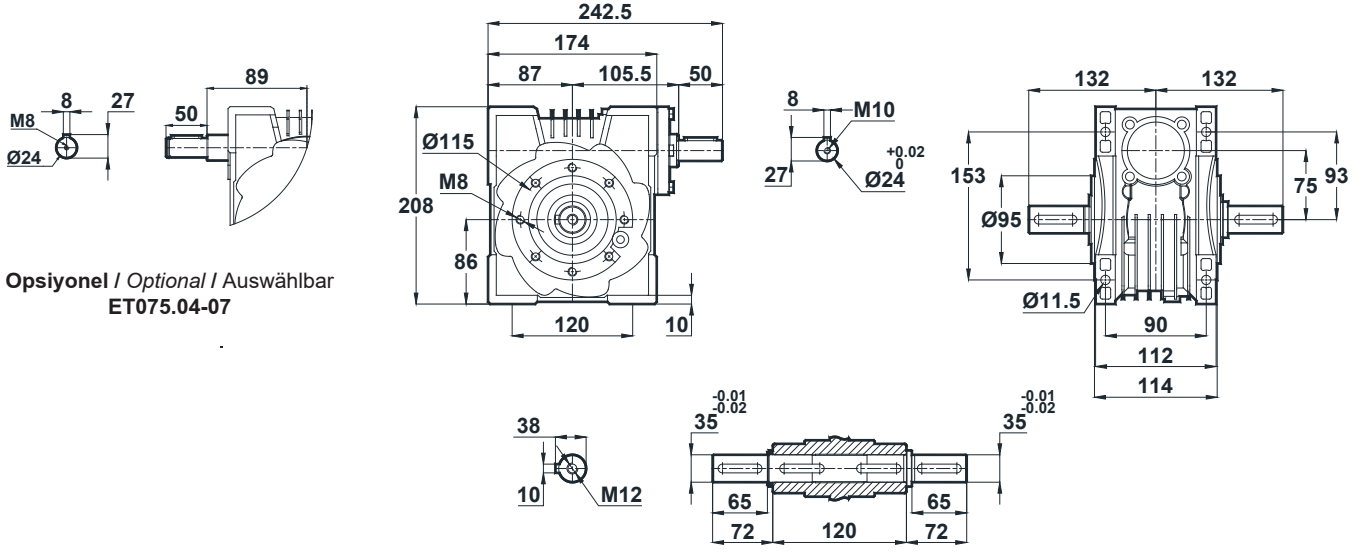

Opsiyonel / Optional / Auswählbar  
ET075.04-07

#### ET075.05

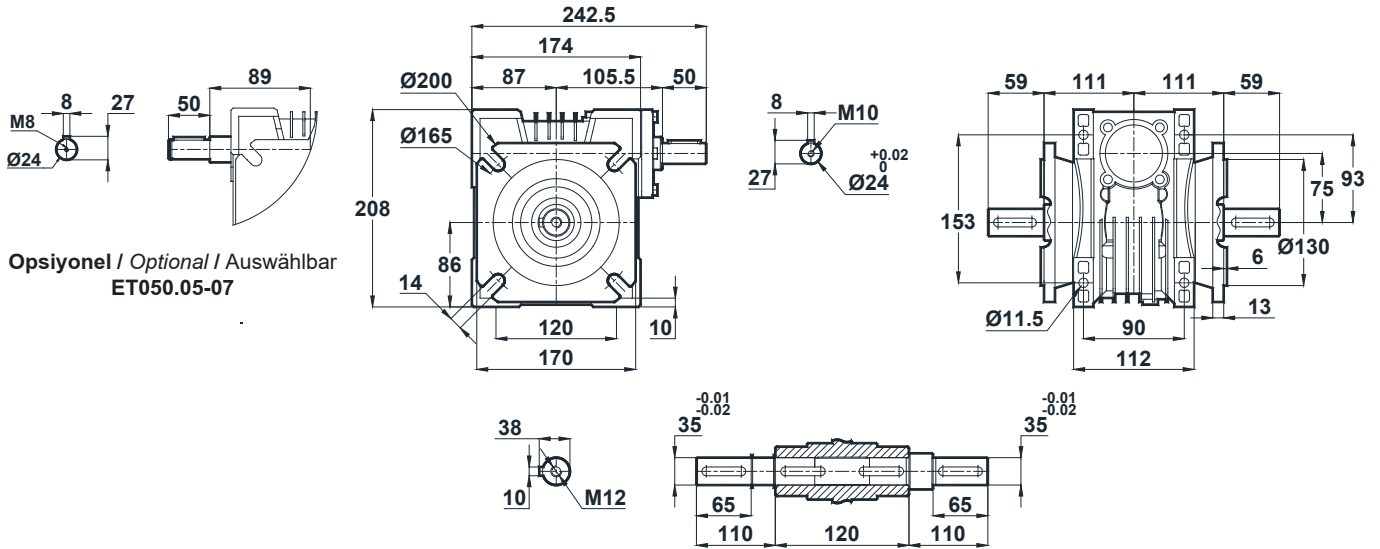

Opsiyonel / Optional / Auswählbar  
ET050.05-07



# Ölçü Sayfaları

## Dimension Pages

### Abmessungsseiten

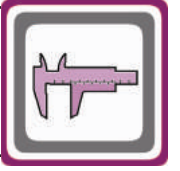

-Mil ucu çekirme deliği DIN 332 sayfa 2 / Tapped center hole to DIN 332, sheet 2 / Zentrierung mit Gewinde DIN 332, Blatt 2

ET075.08

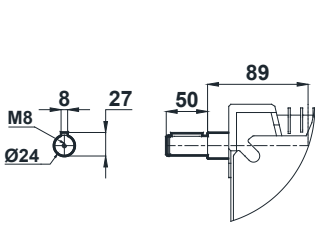

Opsiyonel / Optional / Auswählbar  
ET075.08-07

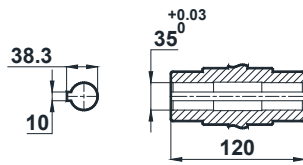
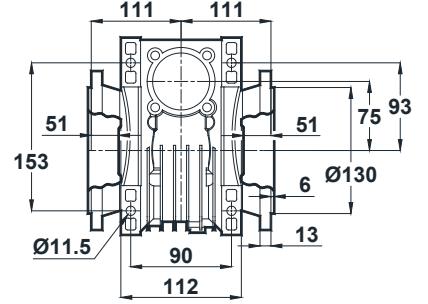
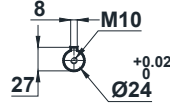
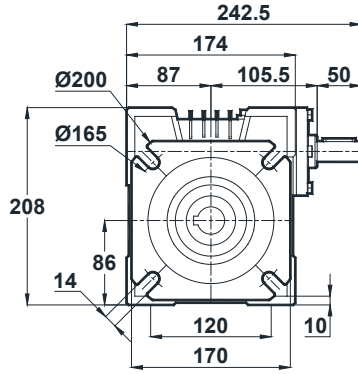



# Ölçü Sayfaları

## Dimension Pages

### Abmessungsseiten

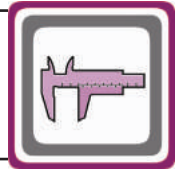

-Mil ucu çekirme deliği DIN 332 sayfa 2 / Tapped center hole to DIN 332, sheet 2 / Zentrierung mit Gewinde DIN 332, Blatt 2

#### ET080.00

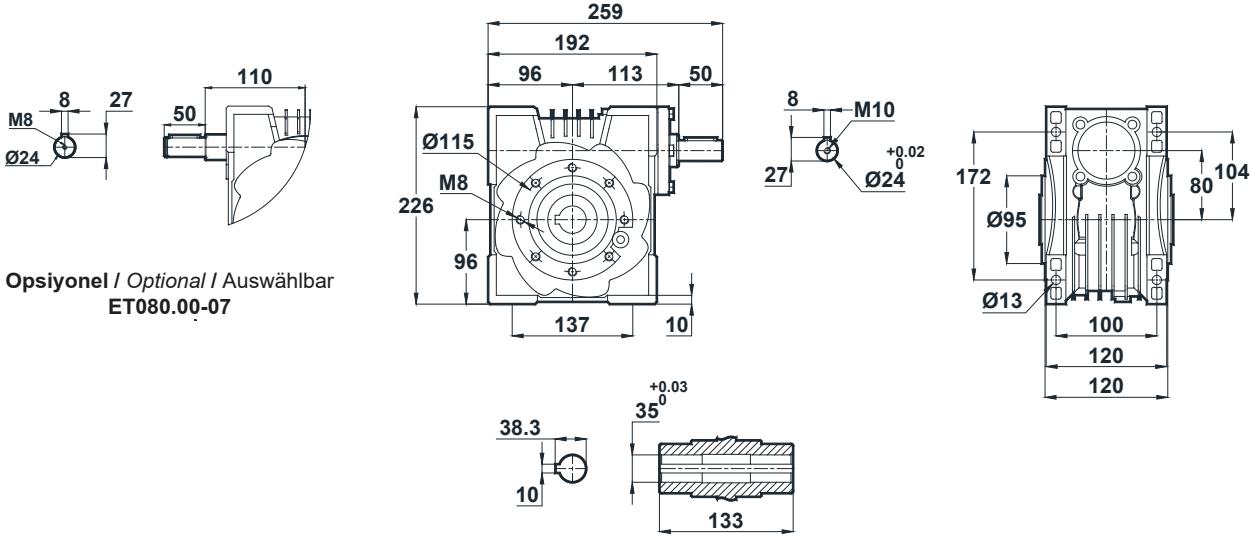

Opsiyonel / Optional / Auswählbar  
ET080.00-07

#### ET080.01

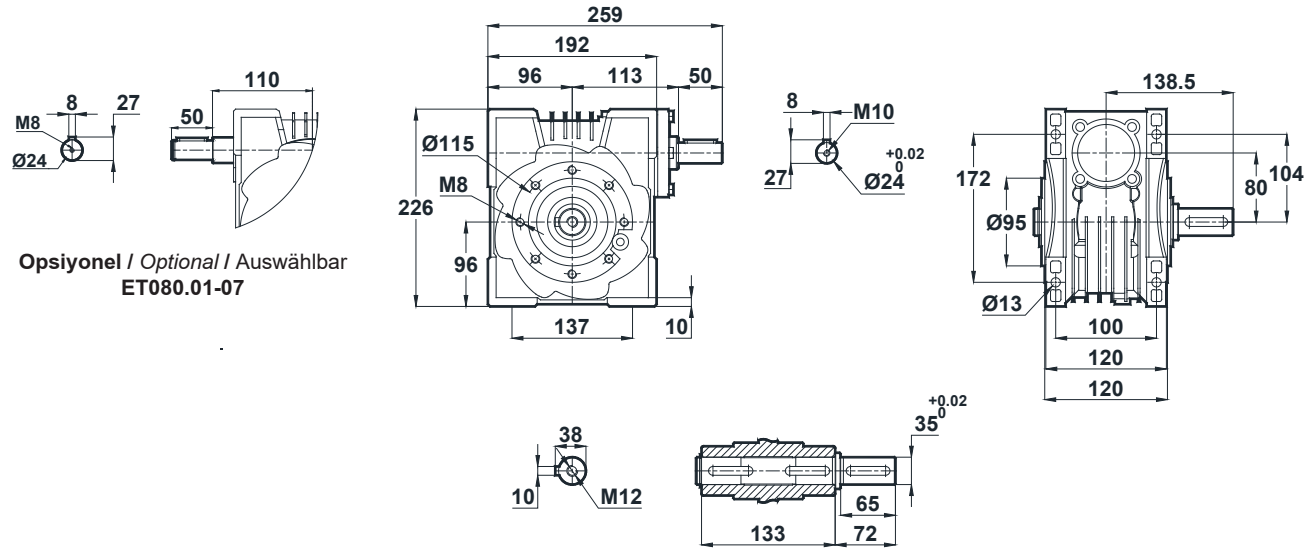

Opsiyonel / Optional / Auswählbar  
ET080.01-07



# Ölçü Sayfaları

## Dimension Pages

### Abmessungsseiten

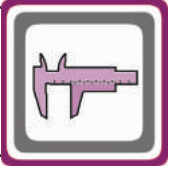

-Mil ucu çekirme deliği DIN 332 sayfa 2 / Tapped center hole to DIN 332, sheet 2 / Zentrierung mit Gewinde DIN 332, Blatt 2

#### ET080.02

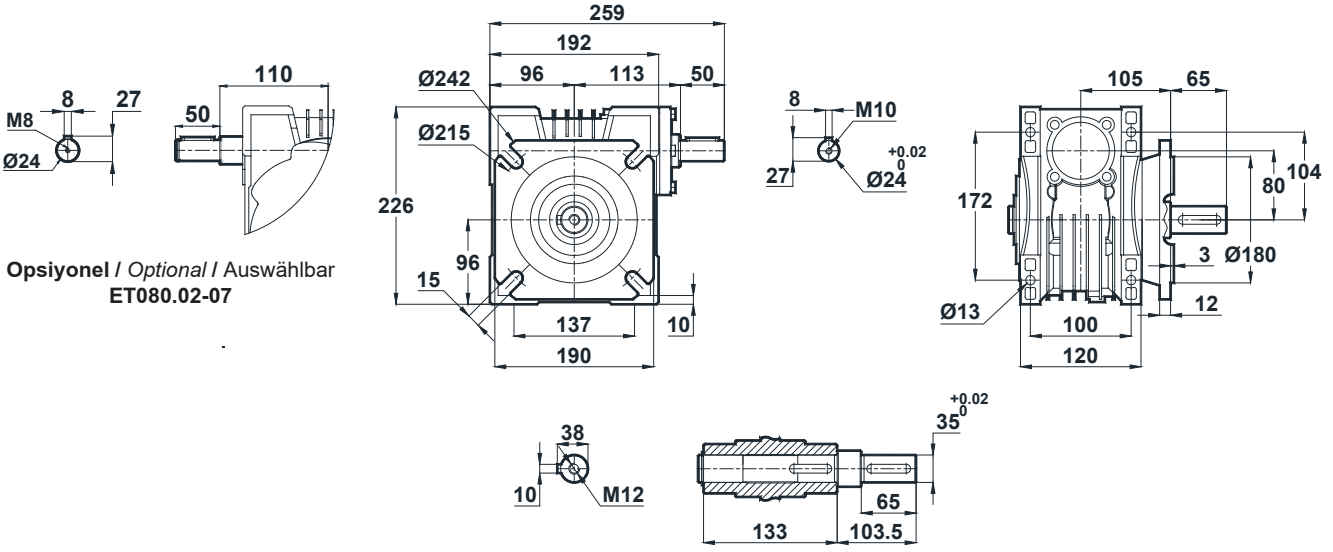

Opsiyonel / Optional / Auswählbar  
ET080.02-07

#### ET080.03

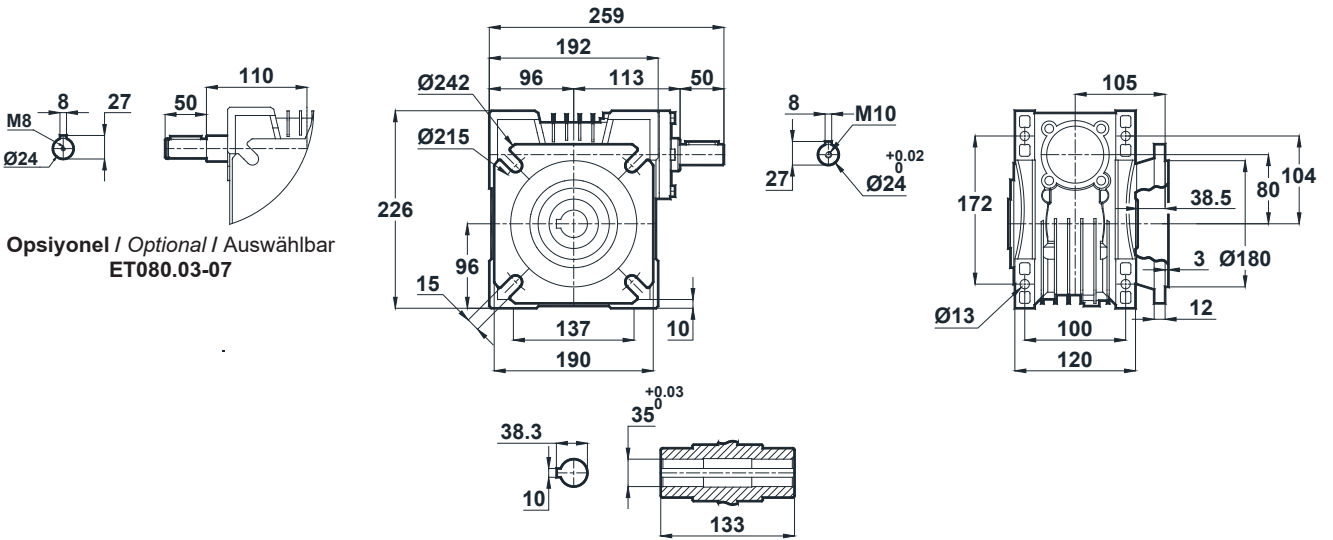

Opsiyonel / Optional / Auswählbar  
ET080.03-07



# Ölçü Sayfaları

## Dimension Pages

### Abmessungsseiten

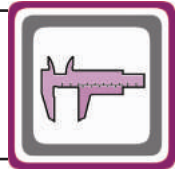

-Mil ucu çekirme deliği DIN 332 sayfa 2 / Tapped center hole to DIN 332, sheet 2 / Zentrierung mit Gewinde DIN 332, Blatt 2

#### ET080.04

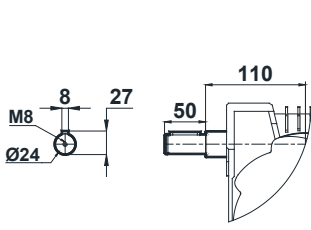

Opsiyonel / Optional / Auswählbar  
ET080.04-07

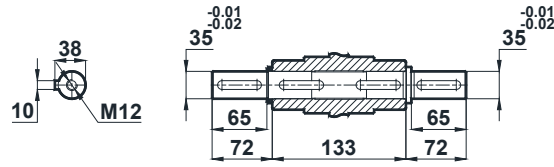
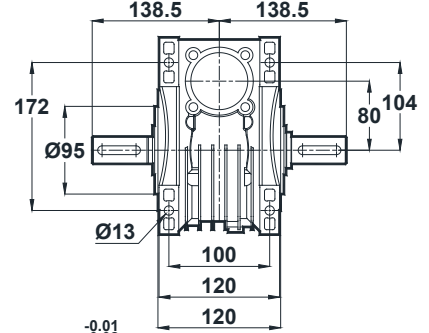
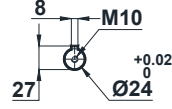
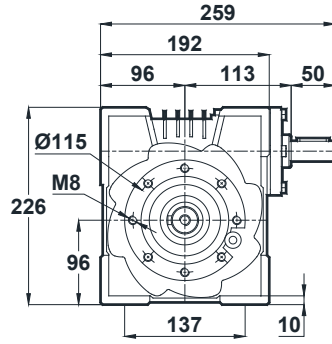

#### ET080.05

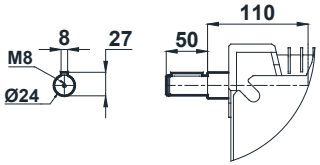

Opsiyonel / Optional / Auswählbar  
ET080.05-07

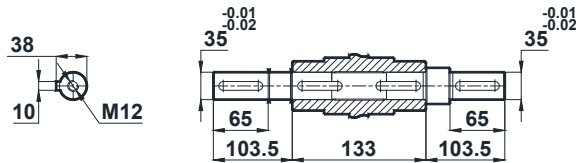
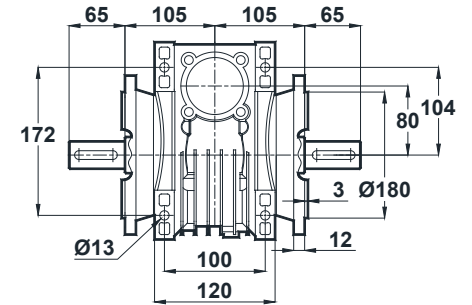
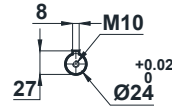
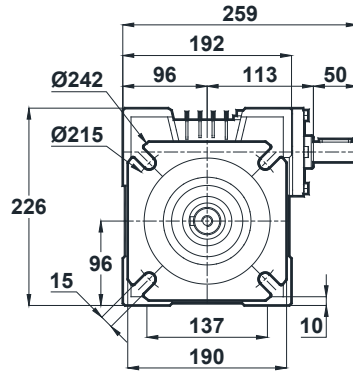



# Ölçü Sayfaları

## Dimension Pages

### Abmessungsseiten

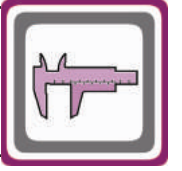

-Mil ucu çekirme deliği DIN 332 sayfa 2 / Tapped center hole to DIN 332, sheet 2 / Zentrierung mit Gewinde DIN 332, Blatt 2

ET080.08

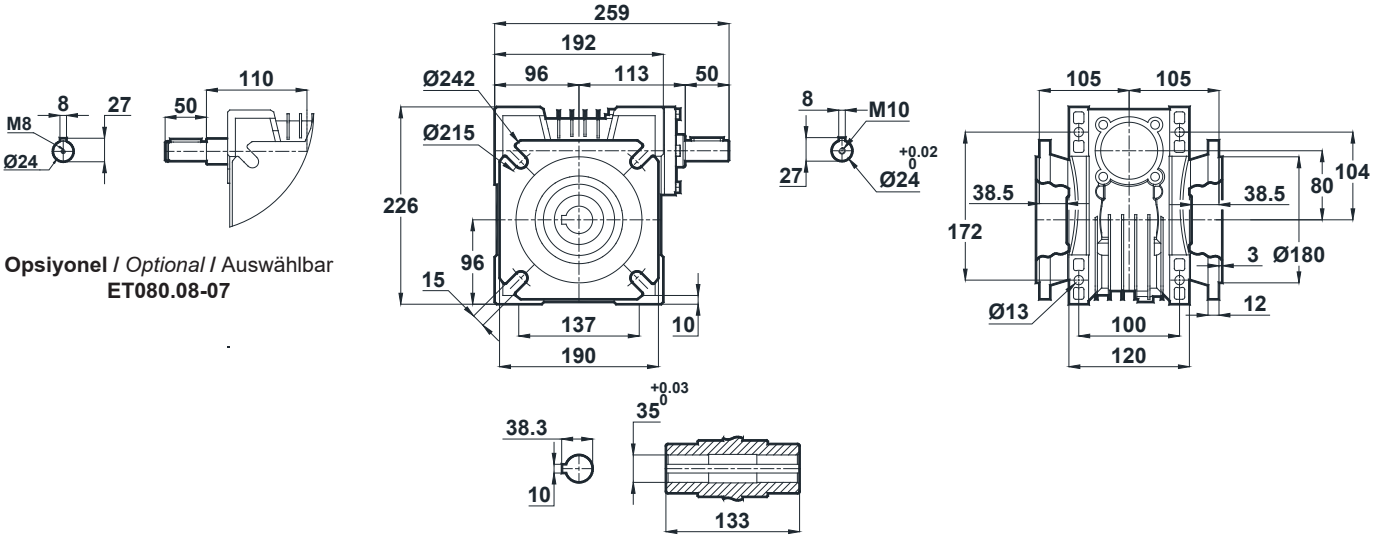



# Ölçü Sayfaları

## Dimension Pages

### Abmessungsseiten

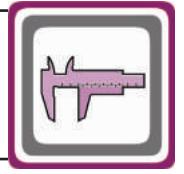

-Mil ucu çekirme deliği DIN 332 sayfa 2 / Tapped center hole to DIN 332, sheet 2 / Zentrierung mit Gewinde DIN 332, Blatt 2

#### ET100.00

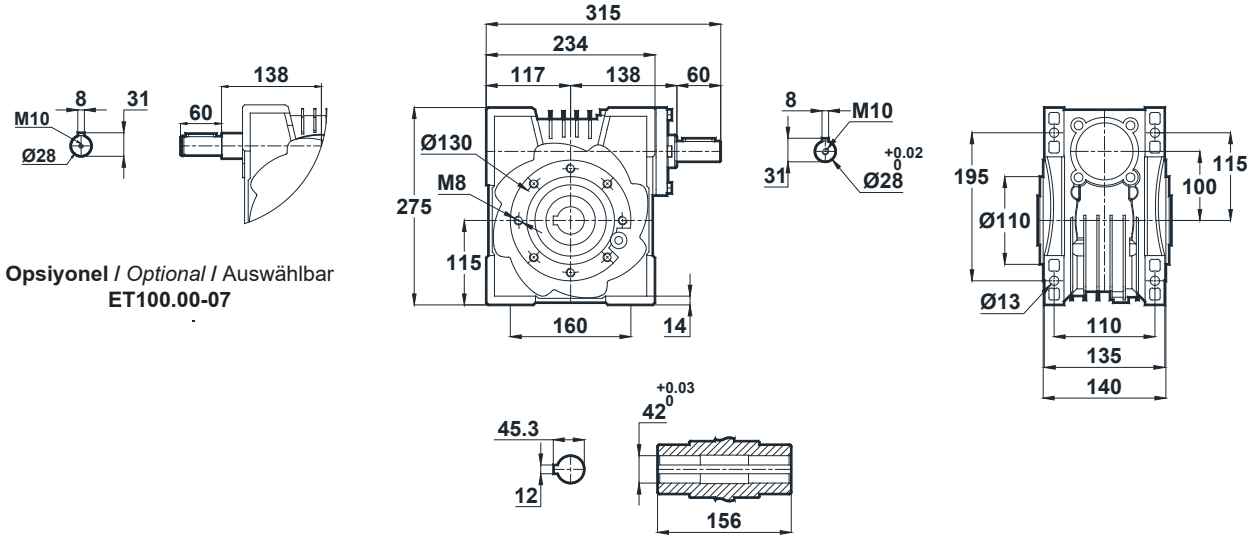

Opsiyonel / Optional / Auswählbar  
ET100.00-07

#### ET100.01

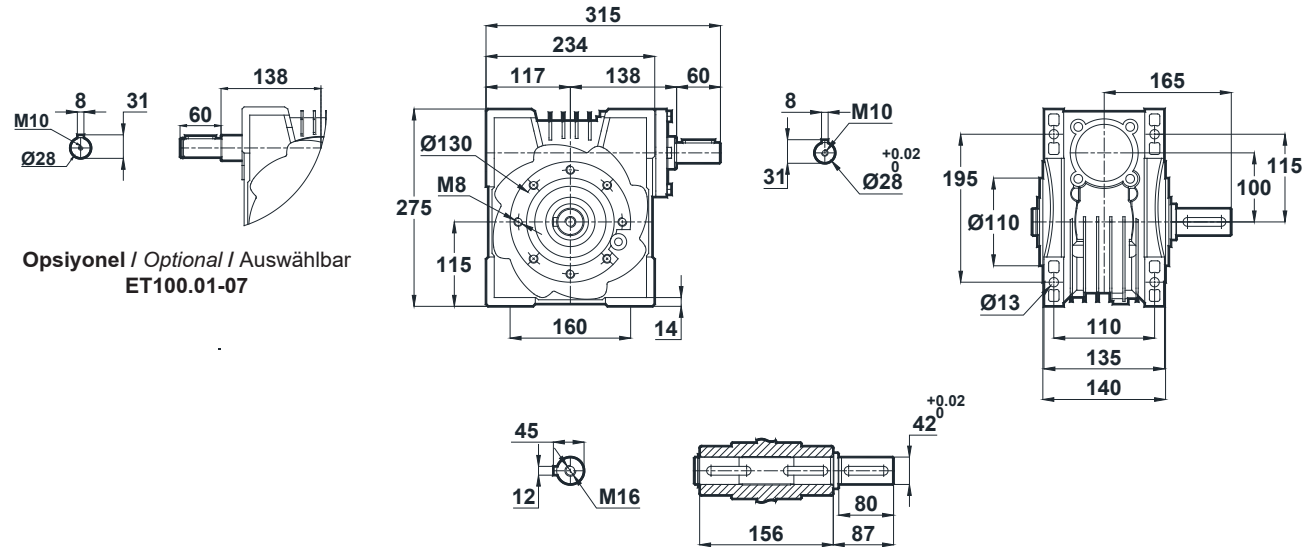

Opsiyonel / Optional / Auswählbar  
ET100.01-07



# Ölçü Sayfaları

## Dimension Pages

### Abmessungsseiten

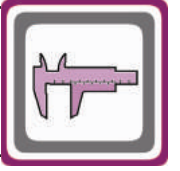

-Mil ucu çekirme deliği DIN 332 sayfa 2 / Tapped center hole to DIN 332, sheet 2 / Zentrierung mit Gewinde DIN 332, Blatt 2

#### ET100.02

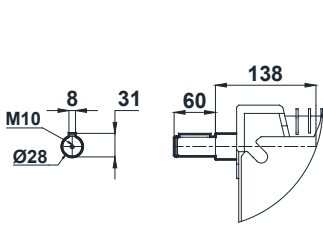

Opsiyonel / Optional / Auswählbar  
ET100.02-07

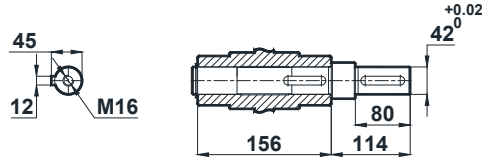
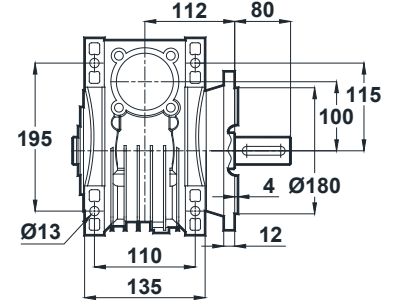
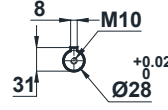
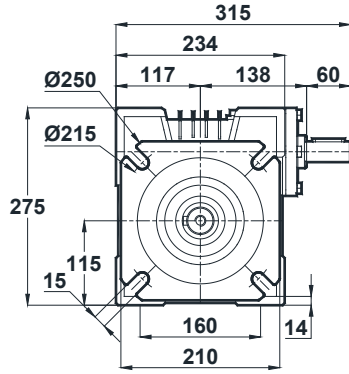

#### ET100.03

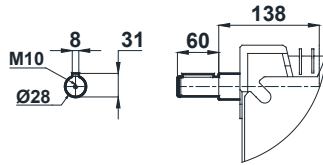

Opsiyonel / Optional / Auswählbar  
ET100.03-07

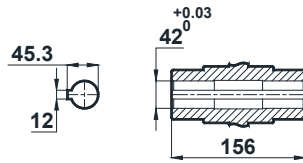
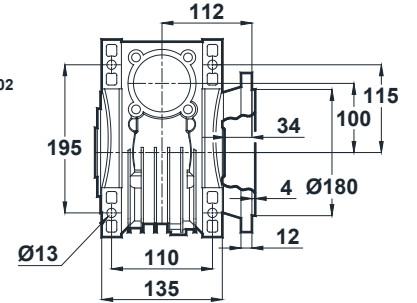
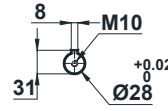
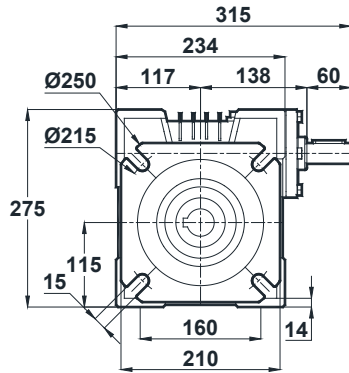





# Ölçü Sayfaları

## Dimension Pages

### Abmessungsseiten

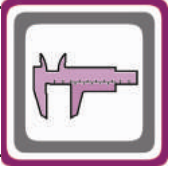

-Mil ucu çekirme deliği DIN 332 sayfa 2 / Tapped center hole to DIN 332, sheet 2 / Zentrierung mit Gewinde DIN 332, Blatt 2

ET100.08

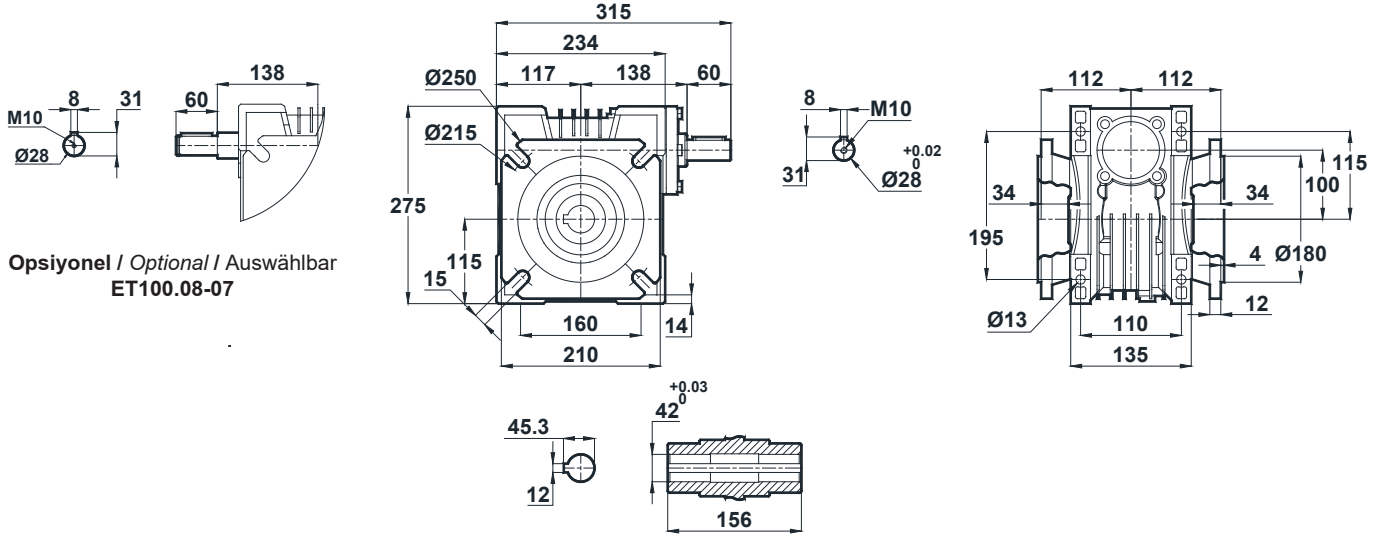

Opsiyonel / Optional / Auswählbar  
ET100.08-07



# Ölçü Sayfaları

## Dimension Pages

### Abmessungsseiten

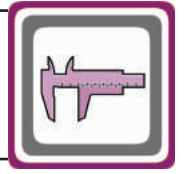

-Mil ucu çekirme deliği DIN 332 sayfa 2 / Tapped center hole to DIN 332, sheet 2 / Zentrierung mit Gewinde DIN 332, Blatt 2

#### ET125.00

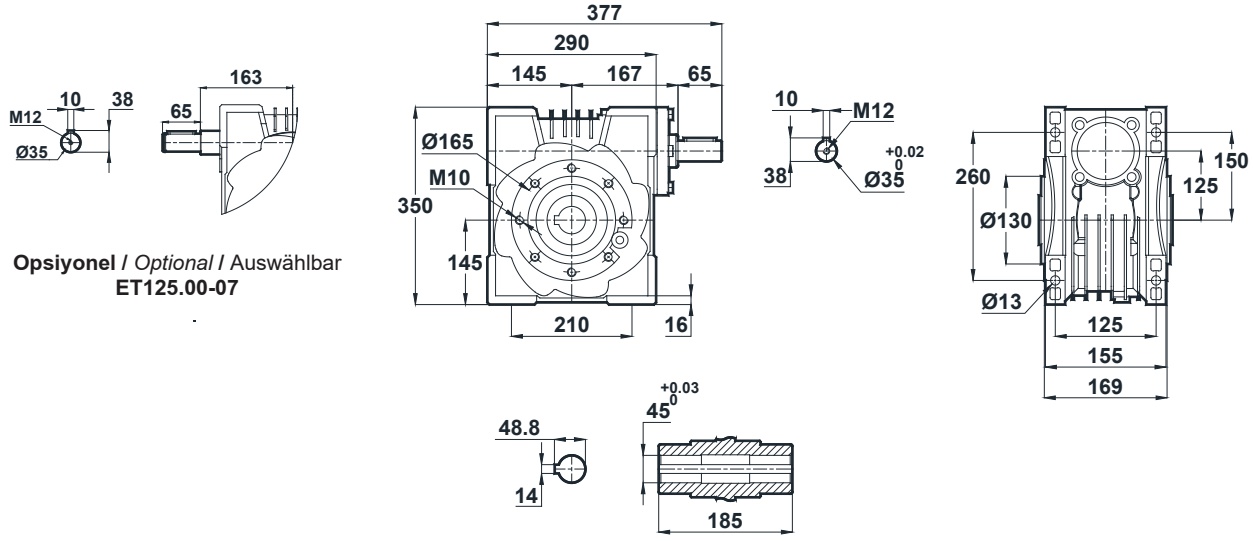

#### ET125.01

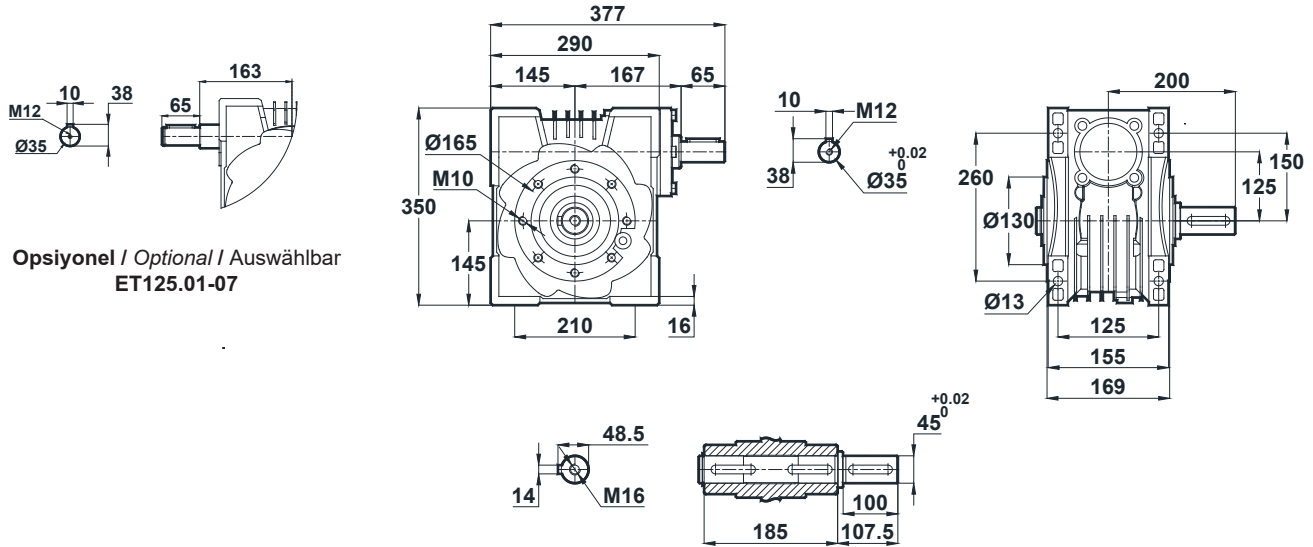



# Ölçü Sayfaları

## Dimension Pages

### Abmessungsseiten

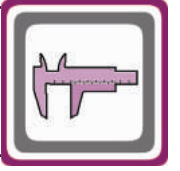

-Mil ucu çekirme deliği DIN 332 sayfa 2 / Tapped center hole to DIN 332, sheet 2 / Zentrierung mit Gewinde DIN 332, Blatt 2

#### ET125.02

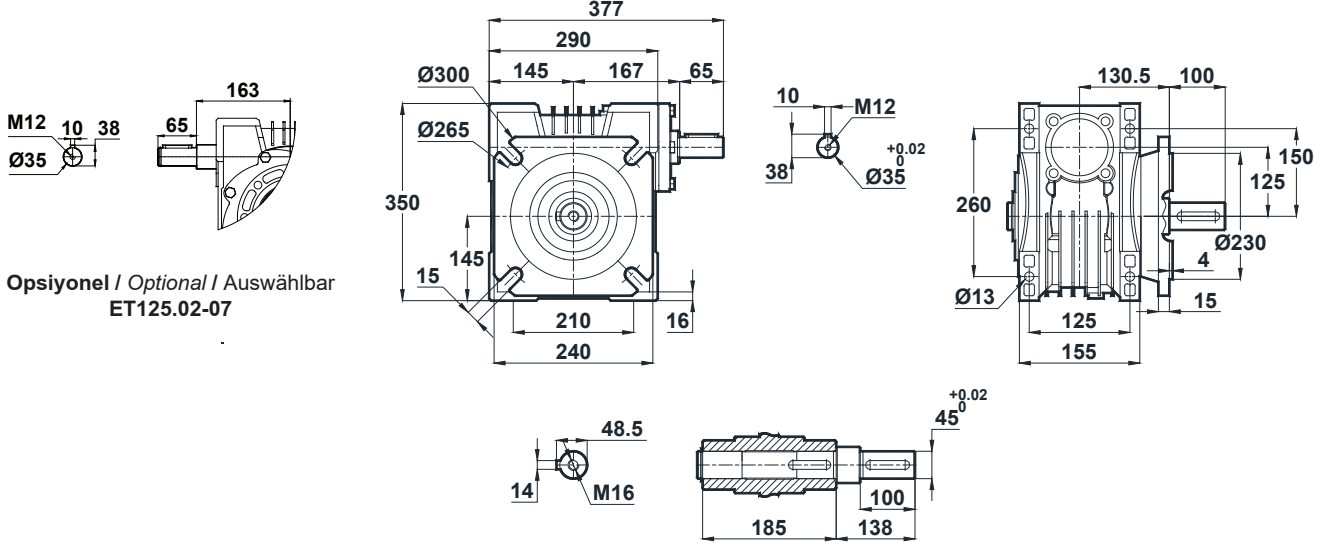

#### ET125.03

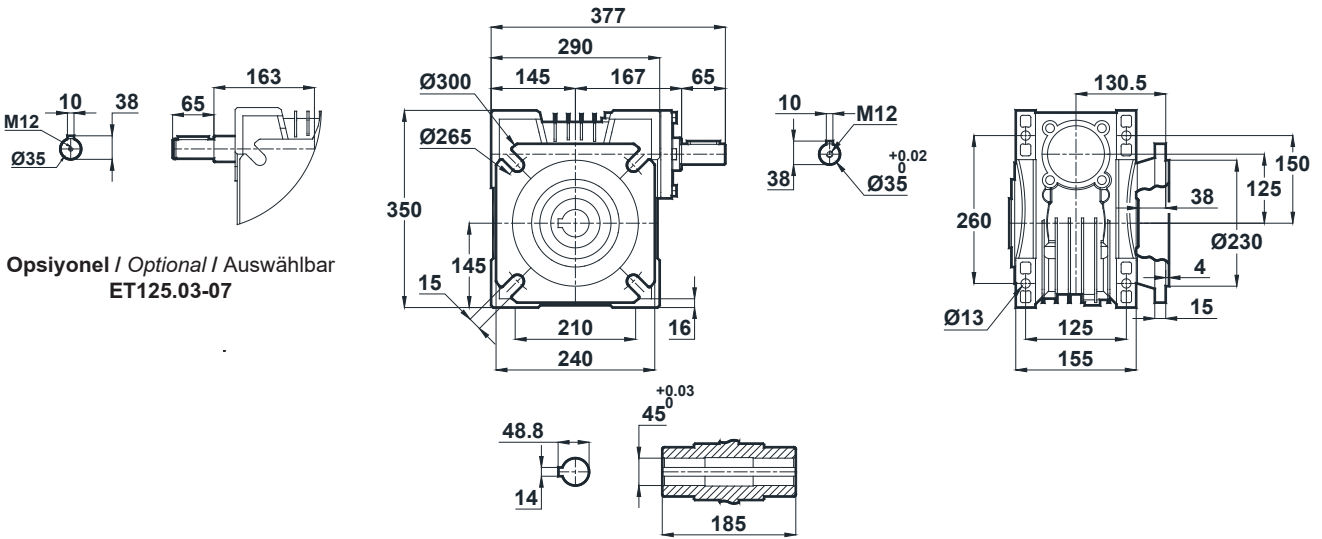



# Ölçü Sayfaları

## Dimension Pages

### Abmessungsseiten

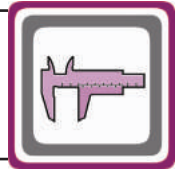

-Mil ucu çekirme deliği DIN 332 sayfa 2 / Tapped center hole to DIN 332, sheet 2 / Zentrierung mit Gewinde DIN 332, Blatt 2

#### ET125.04

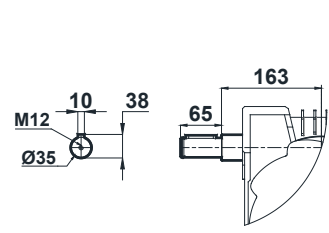

Opsiyonel / Optional / Auswählbar  
ET125.04-07

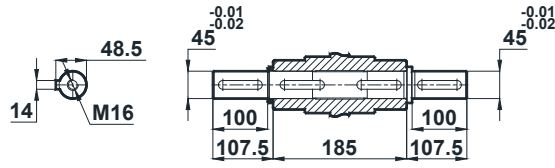
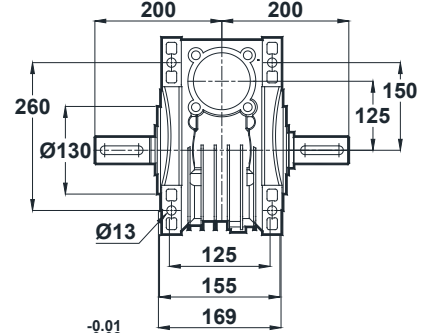
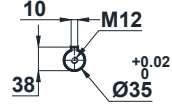
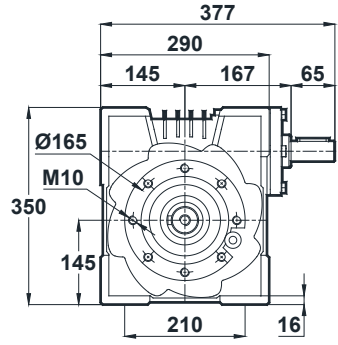

#### ET125.05

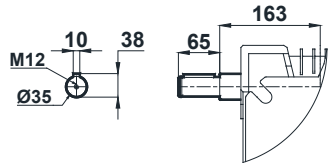

Opsiyonel / Optional / Auswählbar  
ET125.05-07

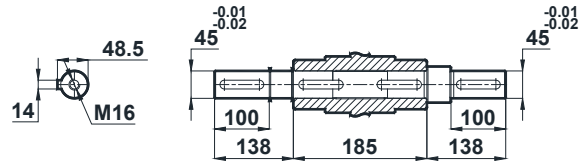
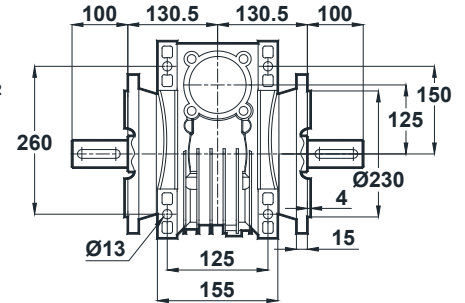
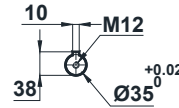
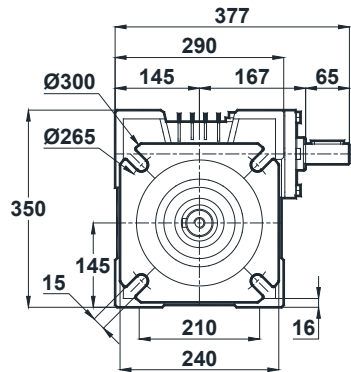



# Ölçü Sayfaları

## Dimension Pages

### Abmessungsseiten

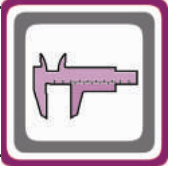

-Mil ucu çekirme deliği DIN 332 sayfa 2 / Tapped center hole to DIN 332, sheet 2 / Zentrierung mit Gewinde DIN 332, Blatt 2

ET125.08

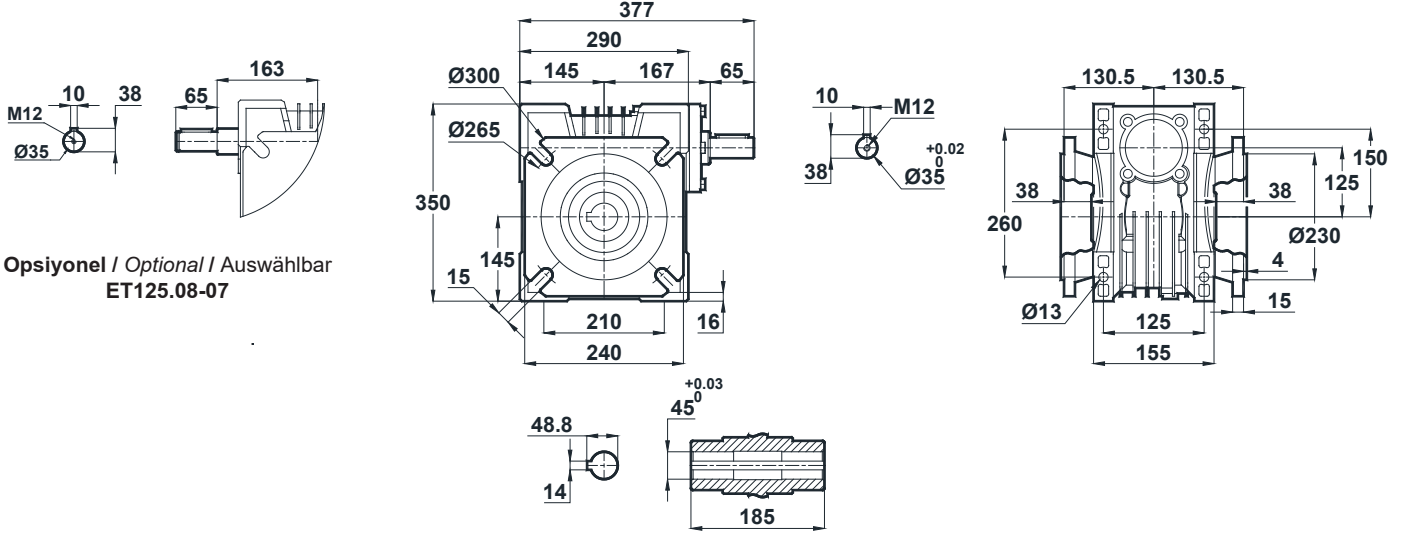

Opsiyonel / Optional / Auswählbar  
ET125.08-07

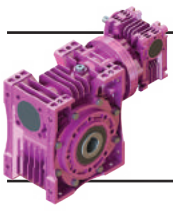

# Ölçü Sayfaları

## Dimension Pages

### Abmessungsseiten

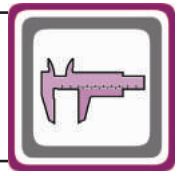

-Mil ucu çekirme deliği DIN 332 sayfa 2 / Tapped center hole to DIN 332, sheet 2 / Zentrierung mit Gewinde DIN 332, Blatt 2

ET040.□ - 030

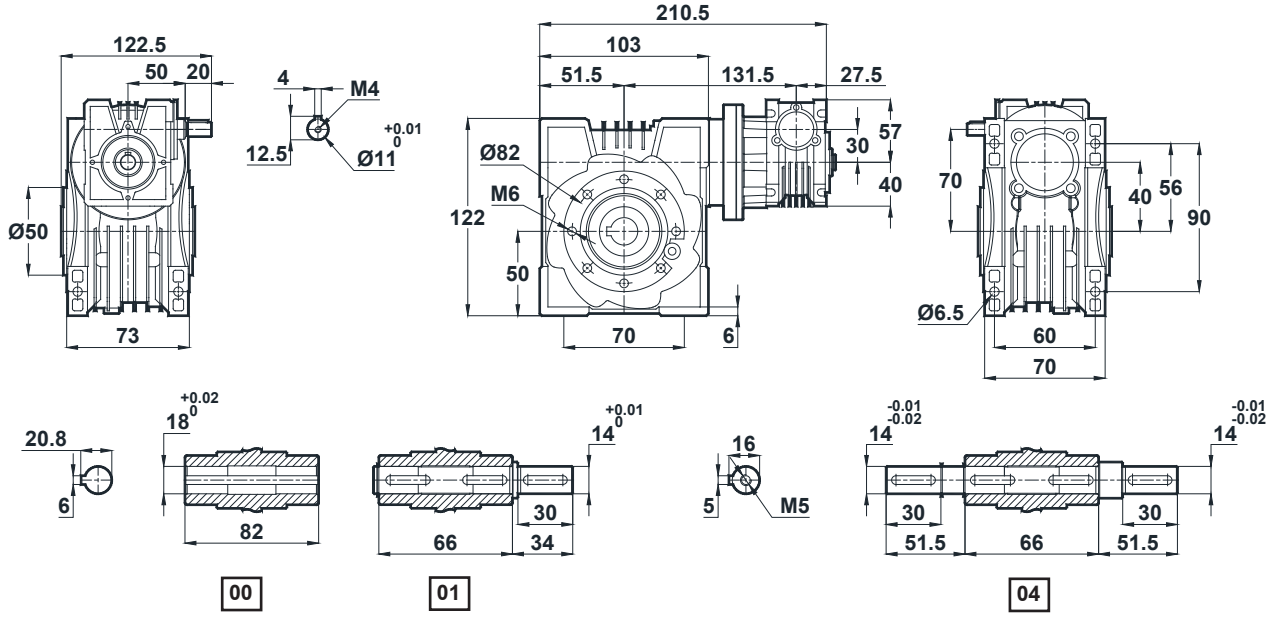

ET040.□ - 030

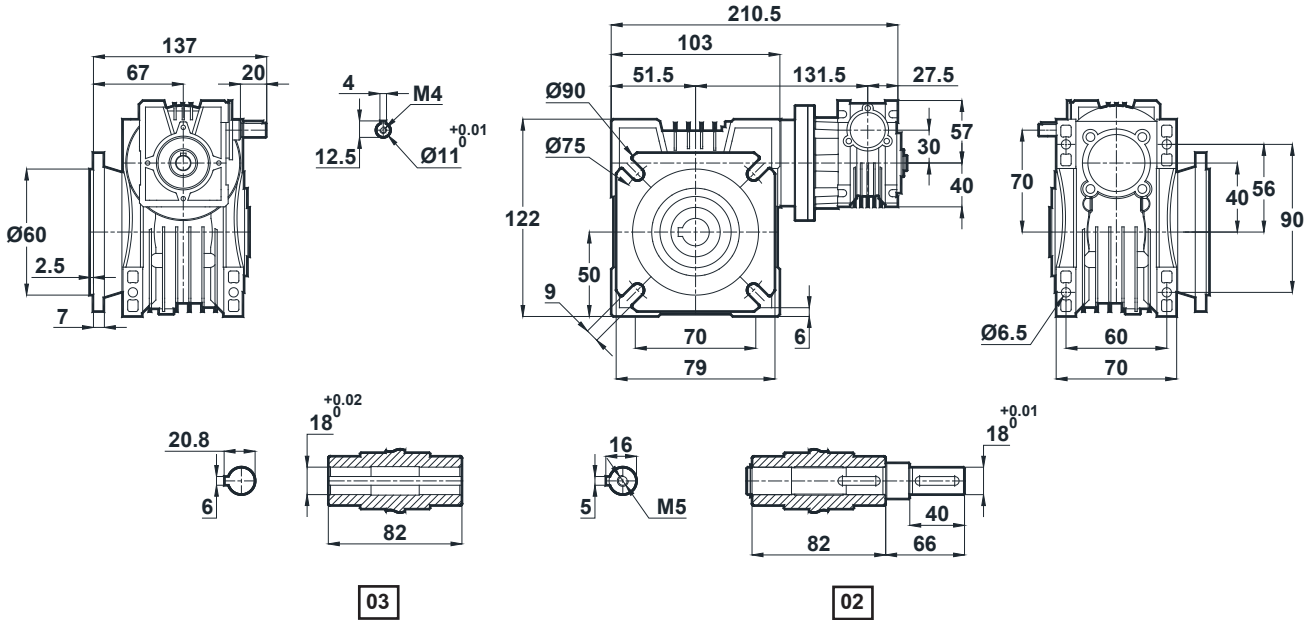

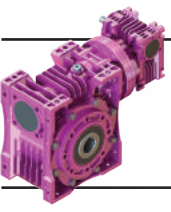

# Ölçü Sayfaları

## Dimension Pages

### Abmessungsseiten

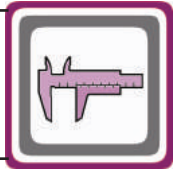

-Mil ucu çekirme deliği DIN 332 sayfa 2 / Tapped center hole to DIN 332, sheet 2 / Zentrierung mit Gewinde DIN 332, Blatt 2

ET050.□ - 030

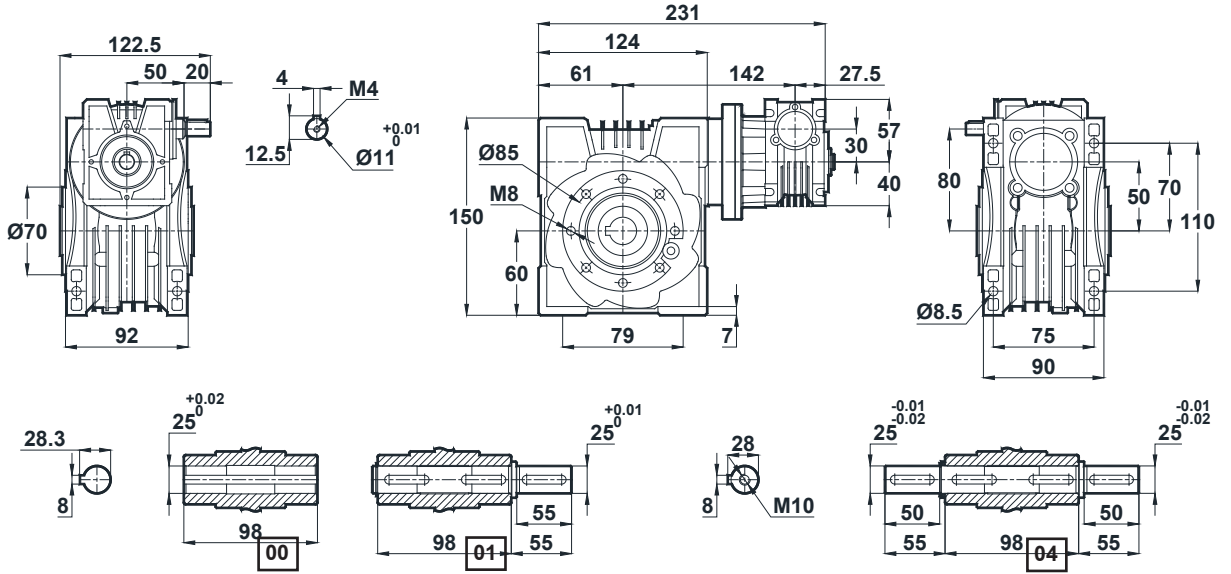

ET050.□ - 030

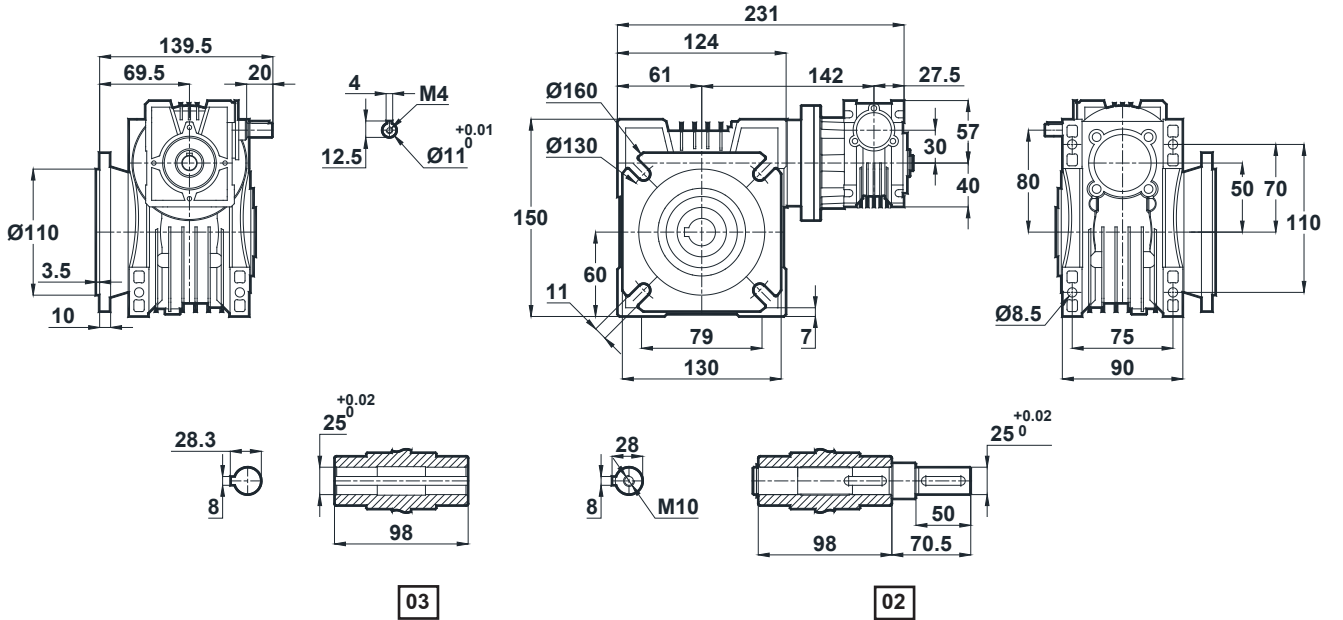



# Ölçü Sayfaları

## Dimension Pages

### Abmessungsseiten

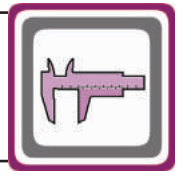

-Mil ucu çekirme deliği DIN 332 sayfa 2 / Tapped center hole to DIN 332, sheet 2 / Zentrierung mit Gewinde DIN 332, Blatt 2

ET063.□ - 030

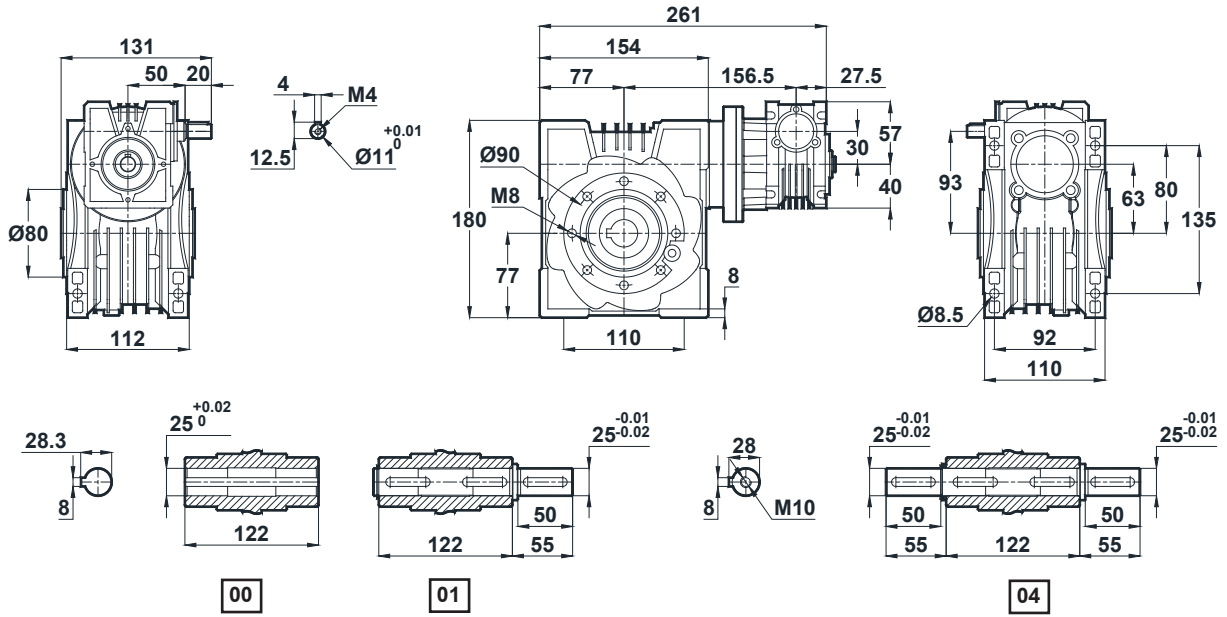

ET063.□ - 030

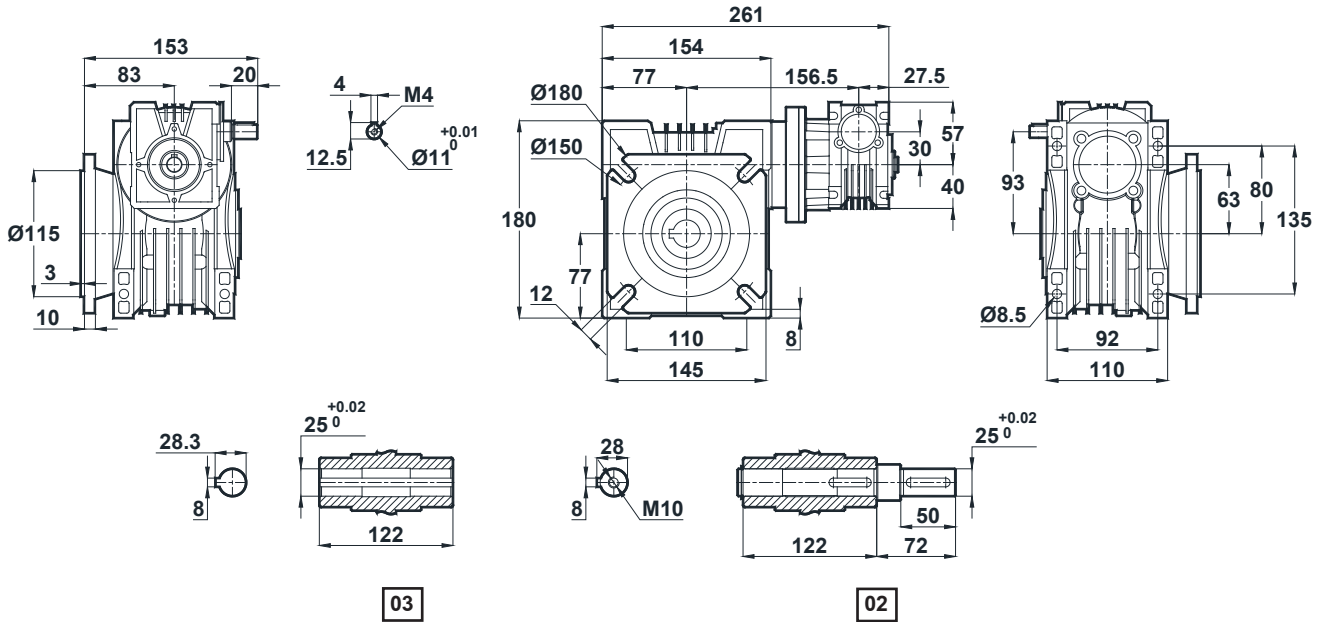



# Ölçü Sayfaları

## Dimension Pages

### Abmessungsseiten

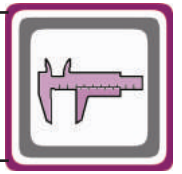

-Mil ucu çekirme deliği DIN 332 sayfa 2 / Tapped center hole to DIN 332, sheet 2 / Zentrierung mit Gewinde DIN 332, Blatt 2

ET075.□ - 030

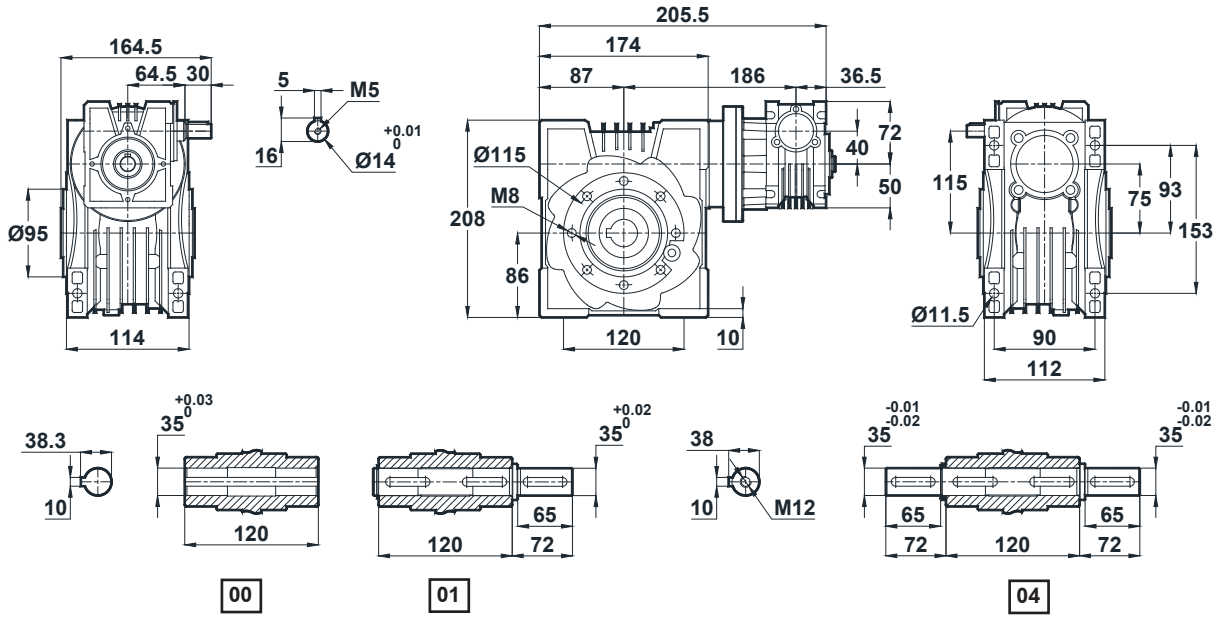

ET075.□ - 030

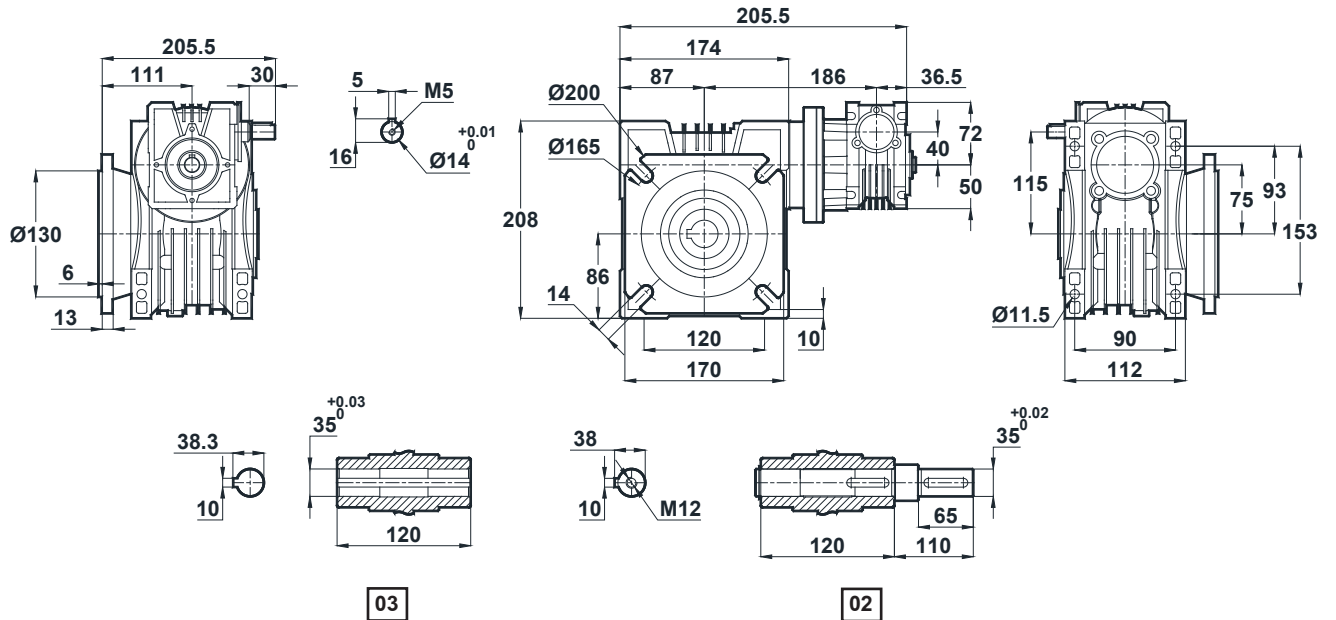

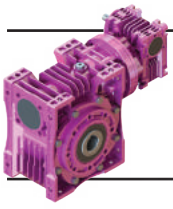

# Ölçü Sayfaları

## Dimension Pages

### Abmessungsseiten

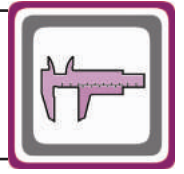

-Mil ucu çekirme deliği DIN 332 sayfa 2 / Tapped center hole to DIN 332, sheet 2 / Zentrierung mit Gewinde DIN 332, Blatt 2

ET080.□ - 040

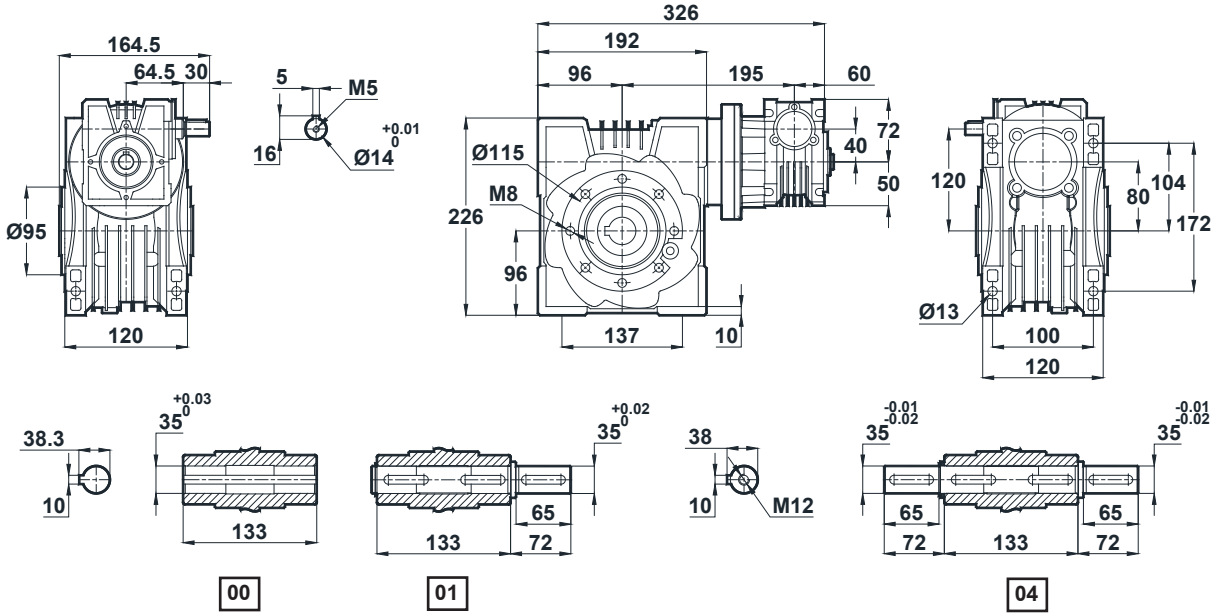

ET080.□ - 040

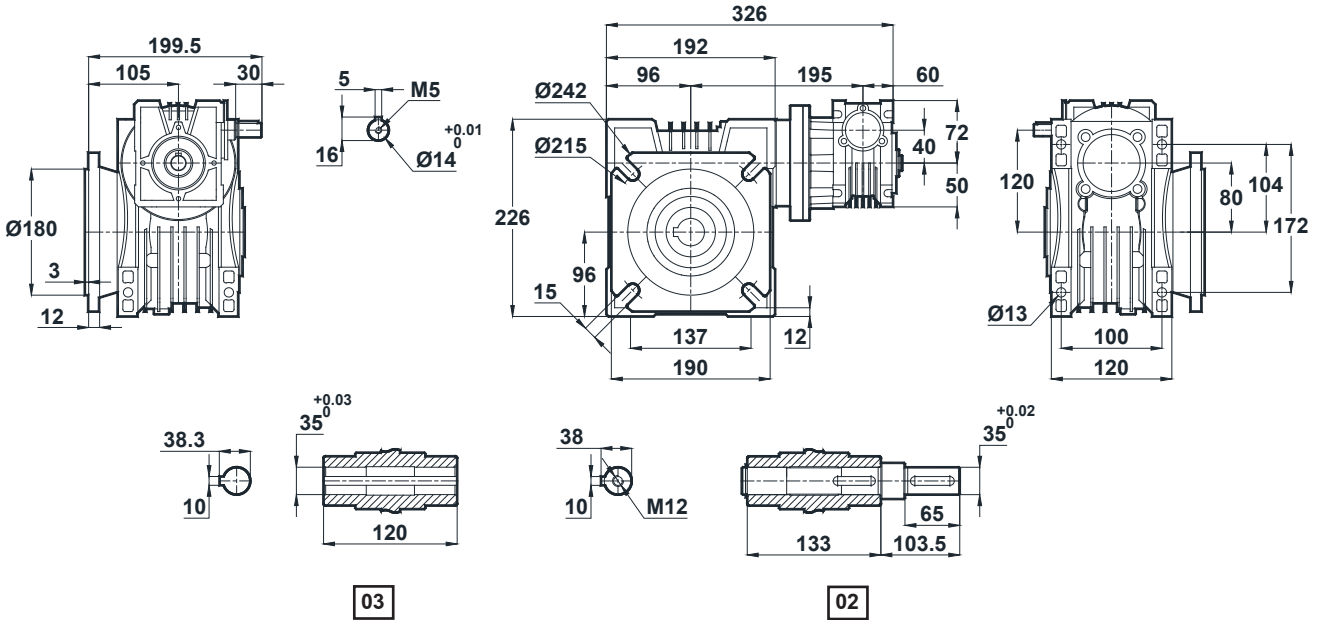



# Ölçü Sayfaları

## Dimension Pages

### Abmessungsseiten

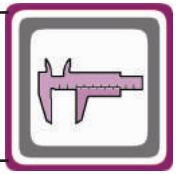

-Mil ucu çekirme deliği DIN 332 sayfa 2 / Tapped center hole to DIN 332, sheet 2 / Zentrierung mit Gewinde DIN 332, Blatt 2

ET100.□ - 050

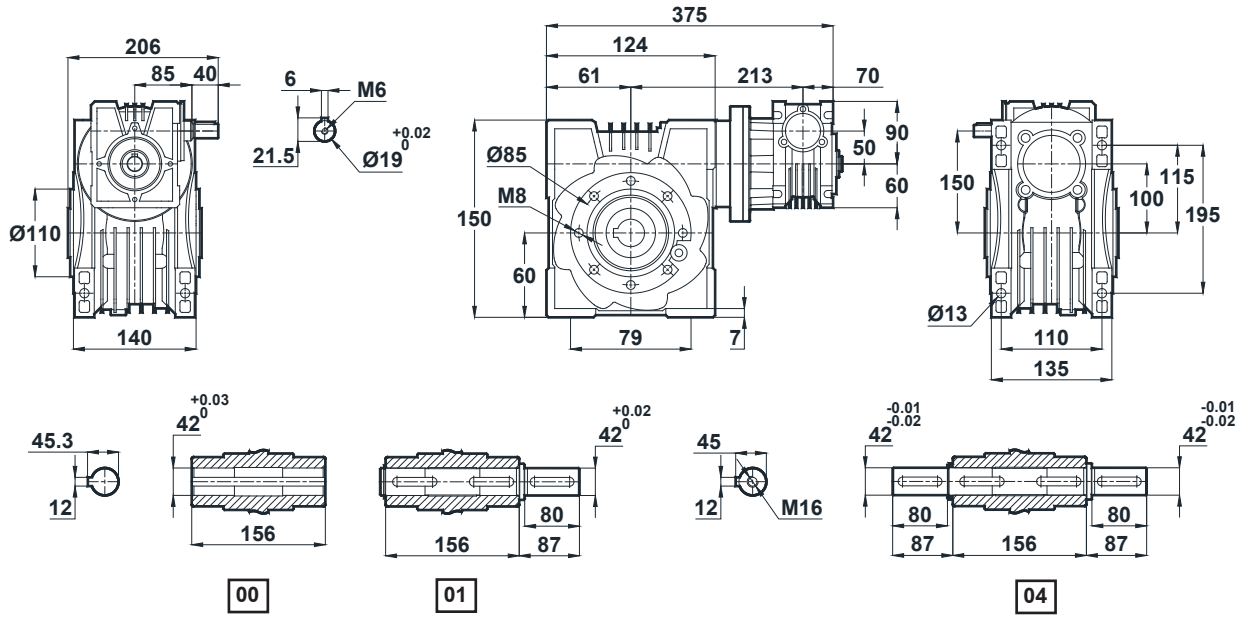

ET100.□ - 050

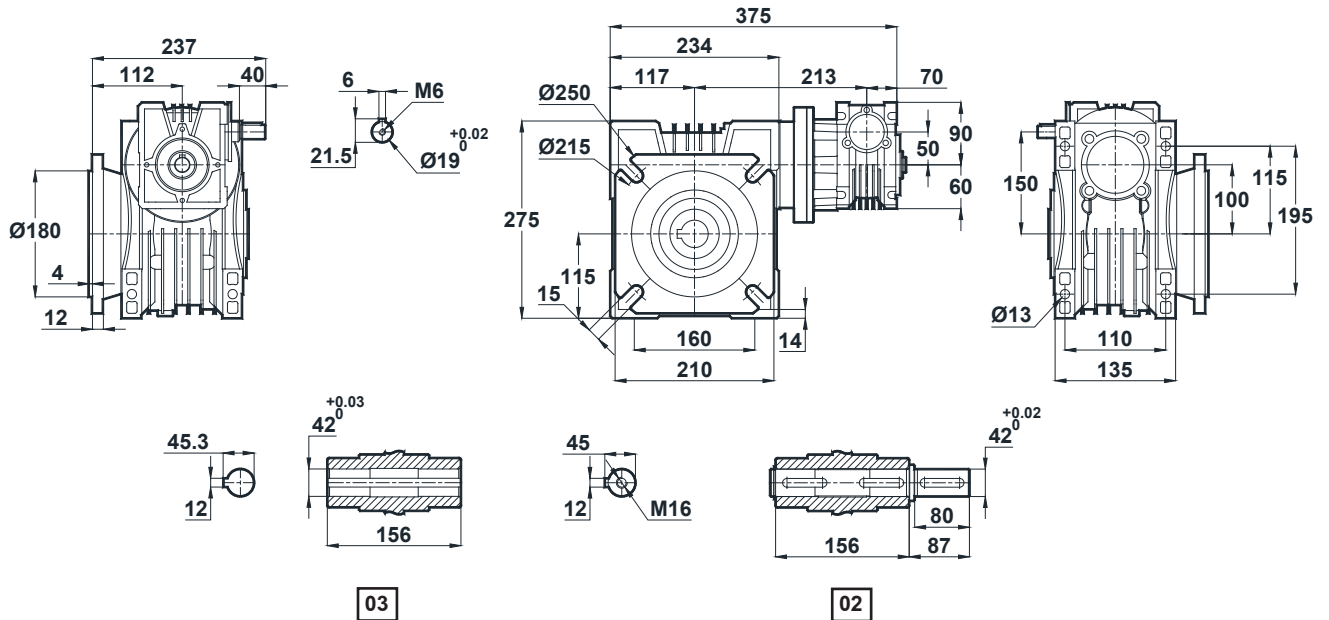







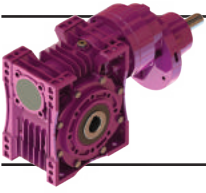

# Ölçü Sayfaları

## Dimension Pages

### Abmessungsseiten

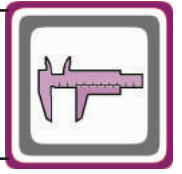

-Mil ucu çekirme deliği DIN 332 sayfa 2 / Tapped center hole to DIN 332, sheet 2 / Zentrierung mit Gewinde DIN 332, Blatt 2

EN075.□ - NT11

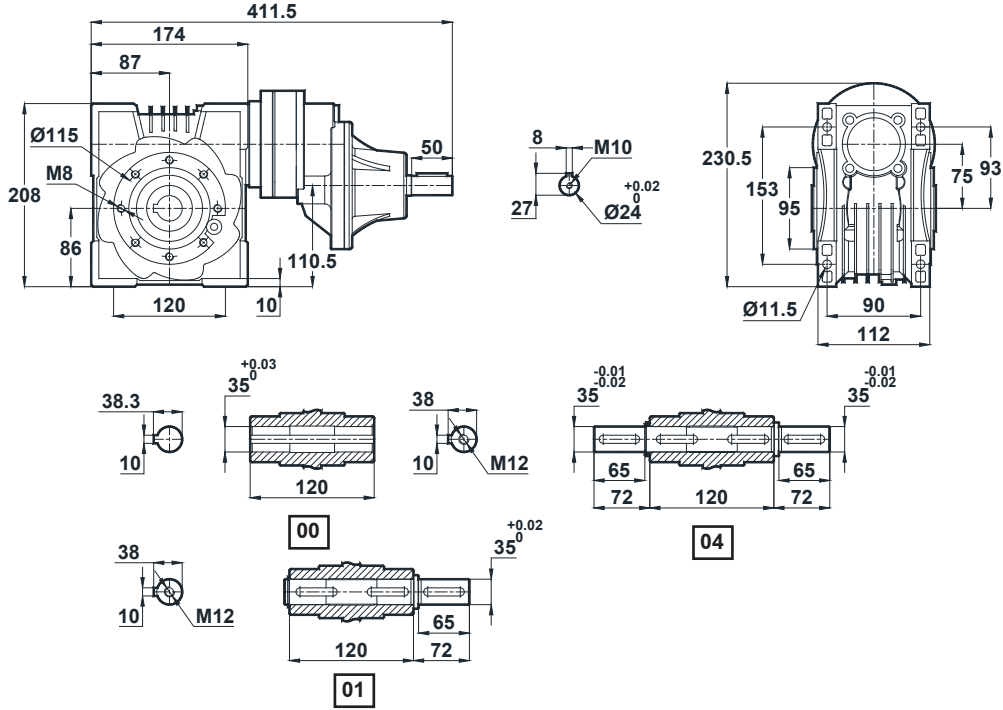

EN075.□ - NT11

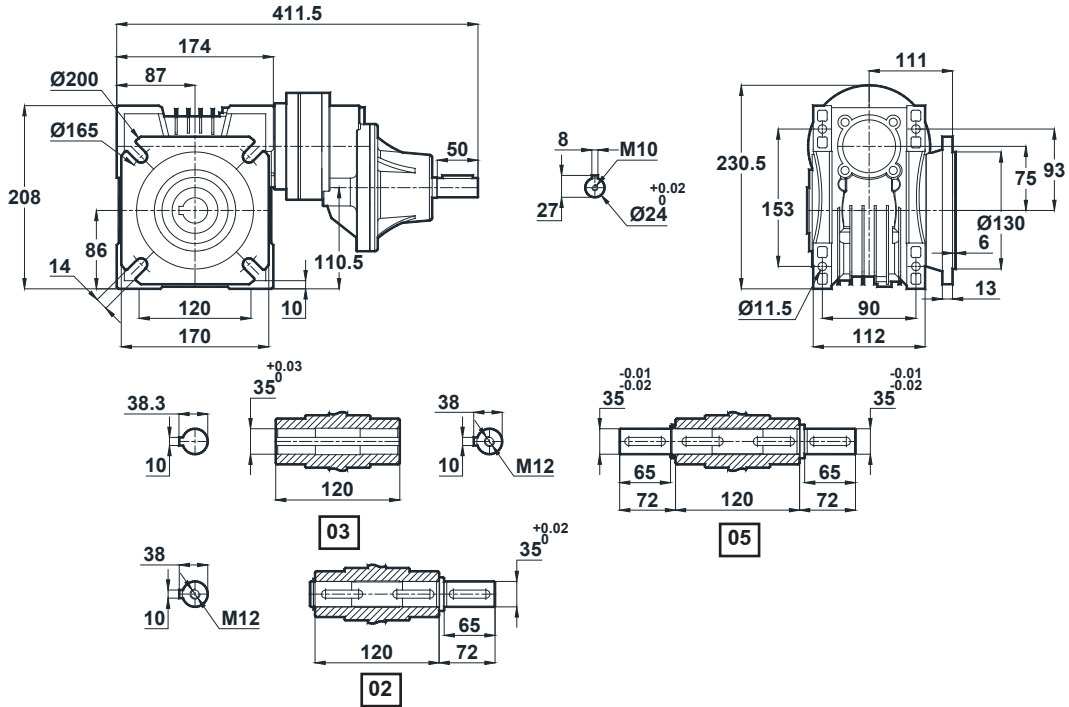

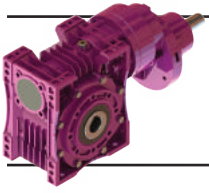

# Ölçü Sayfaları Dimension Pages Abmessungenseiten

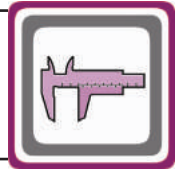

-Mil ucu çekirme deliği DIN 332 sayfa 2 / Tapped center hole to DIN 332, sheet 2 / Zentrierung mit Gewinde DIN 332, Blatt 2

EN080.□ - NT11

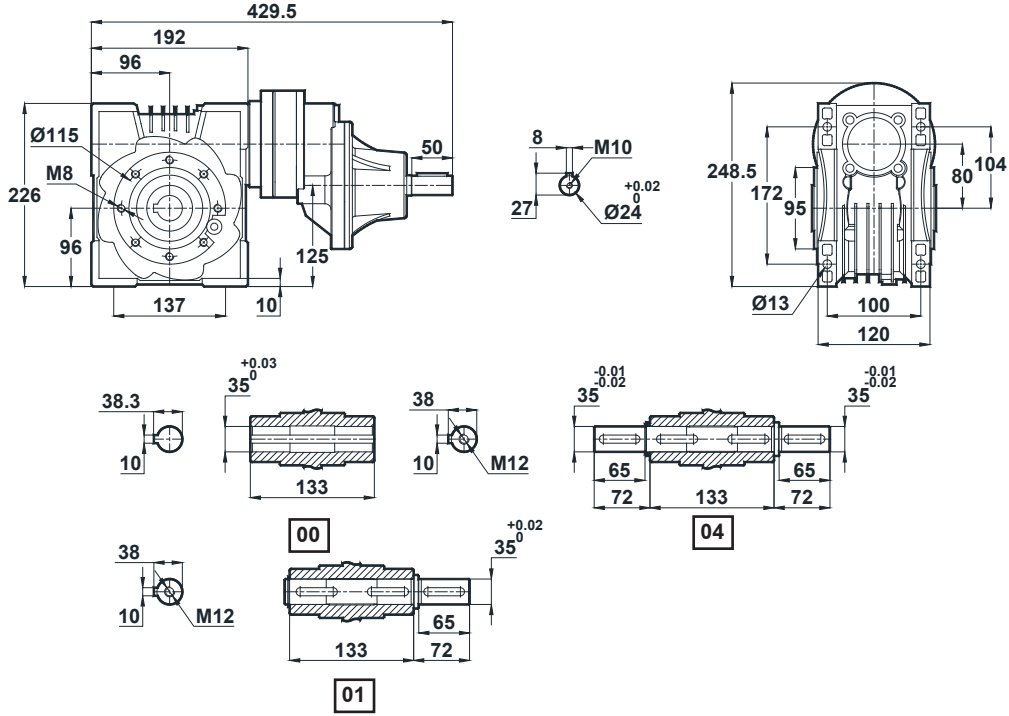

EN080.□ - NT11

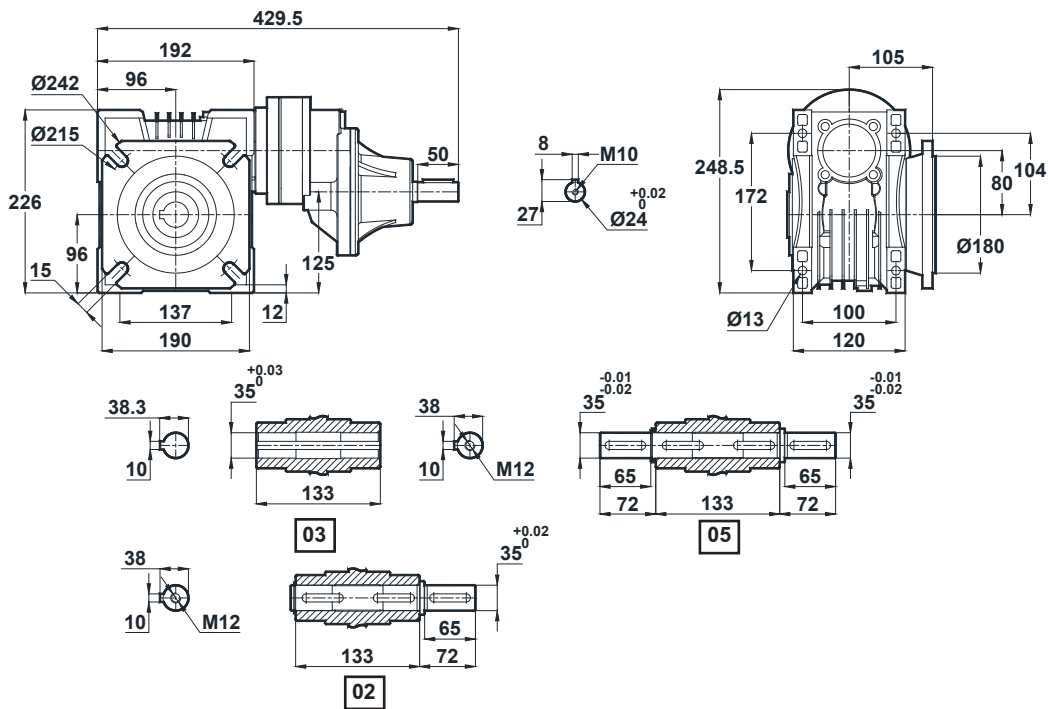

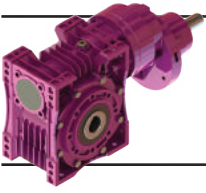

# Ölçü Sayfaları Dimension Pages Abmessungenseiten



-Mil ucu çekirme deliği DIN 332 sayfa 2 / Tapped center hole to DIN 332, sheet 2 / Zentrierung mit Gewinde DIN 332, Blatt 2

EN100.□ - NT11

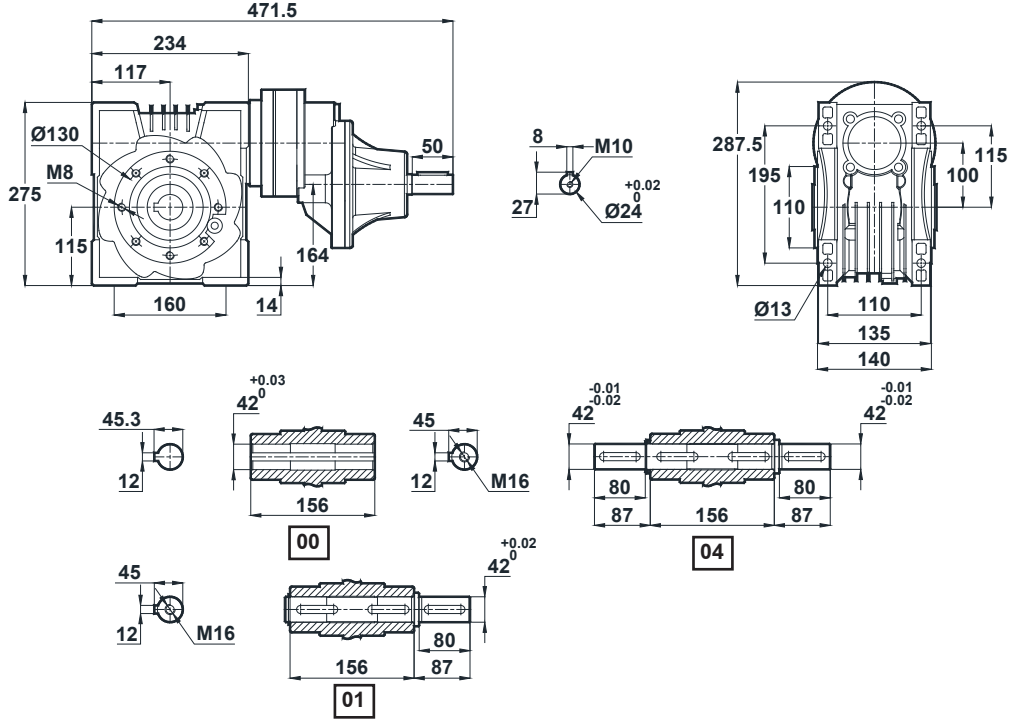

EN100.□ - NT11

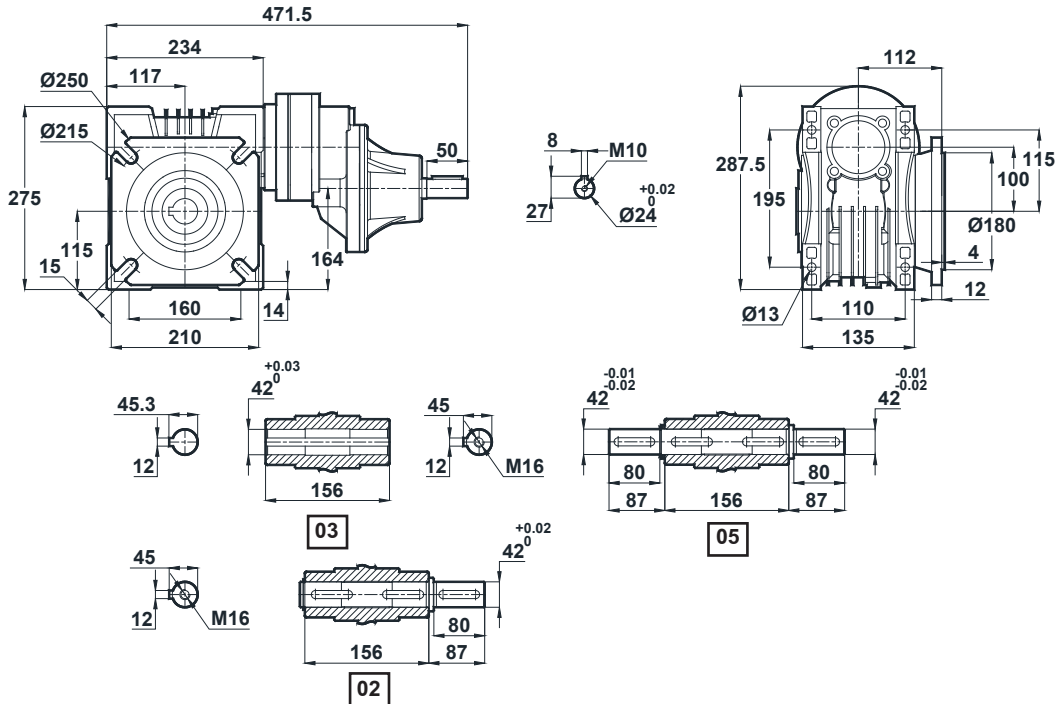



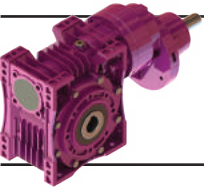

# Ölçü Sayfaları

## Dimension Pages

### Abmessungsseiten

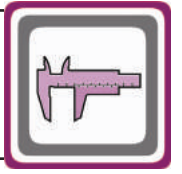

Mil Flanş Ağırlıkları / Shaft and Flange Weights / Gewichte von Wellen und Flanschen

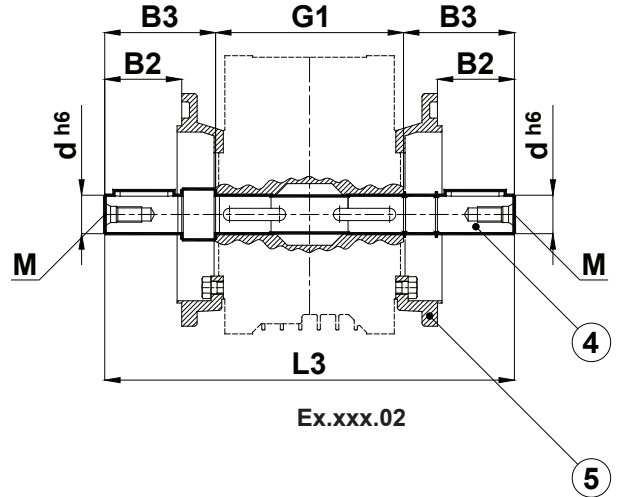
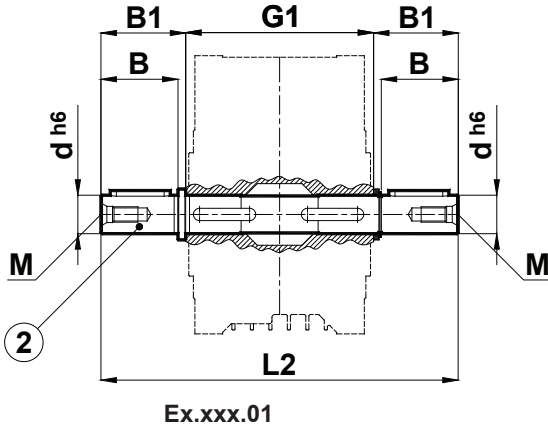
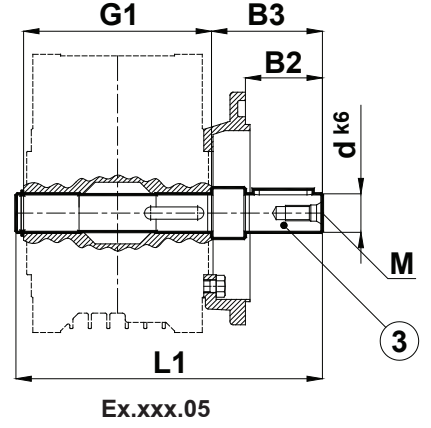
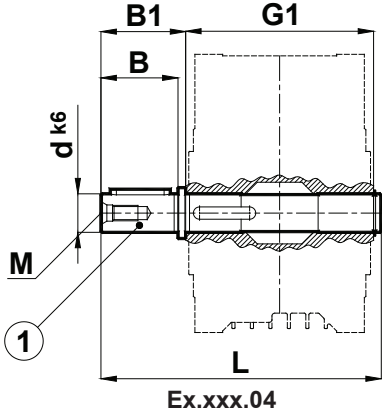

Tip Type Typ	Montaj Ölçüleri / Mounting Dimensions / Befestigungsmaße													Ağırlıklar / Weight / Gewicht				
	d	B	B1	B2	B3	G1	L	L1	L2	L3	M	b1	t1	1	2	3	4	5
E.030..	14	30	34	30	51,5	66	103	134	169	120,5	M5	5	16	0,18	0,20	0,35	0,27	0,15
E.040..	18	40	44,5	40	66	82	130	171	214	151,5	M6	6	20,5	0,35	0,30	0,55	0,40	0,20
E.050..	25	50	55	50	70,5	98	158	208	239	173	M10	8	28	0,70	0,50	0,90	0,60	0,30
E.063..	25	50	55	50	72	122	182	232	266	199	M10	8	28	1,10	0,90	1,40	1,00	0,40
E.075..	35	65	72	65	116	120	197	264	352	235	M12	10	38	2,10	1,50	3,15	1,90	0,70
E.080..	35	65	72	65	103,5	133	210	277	340	241,5	M12	10	38	2,25	1,60	3,0	2,00	0,90
E.100..	40	80	87	80	114	156	249	330	384	276	M16	12	43	5,10	3,90	6,50	4,50	3,65
E.125..	45	100	107,5	100	142	185	300	400	469	335	M16	14	48,5	8,70	6,50	10,60	7,40	6,80



# Ölçü Sayfaları Dimension Pages Abmessungsseiten

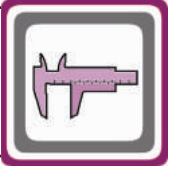

Moment Kolu / Torque Arm / Drehmomentstütze

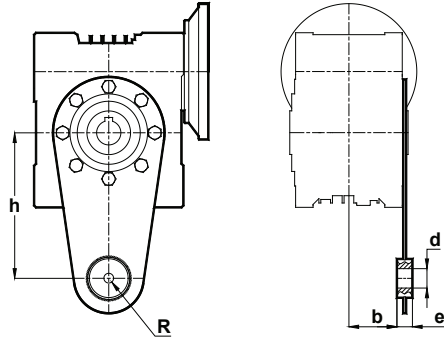

Tipi Type Typ	b	e	d	h	R	Parça No Part No Teil Nr
E.030..	22	14	10	85	25	9E030
E.040..	31	14	10	100	25	9E040
E.050..	38	16	10	100	32	9E050
E.063..	49,5	16	10	150	36	9E063
E.075..	49,5	25	20	200	45	9E075
E.080..	49,5	25	20	200	45	9E080
E.100..	57,5	30	25	250	50	9E100
E.125..	72	30	25	300	55	9E125

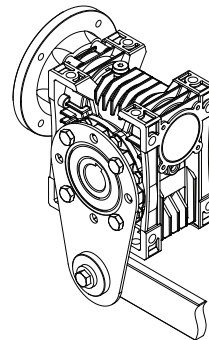
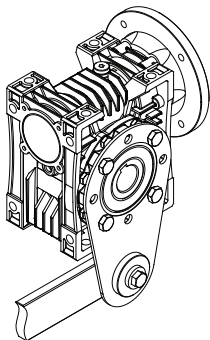
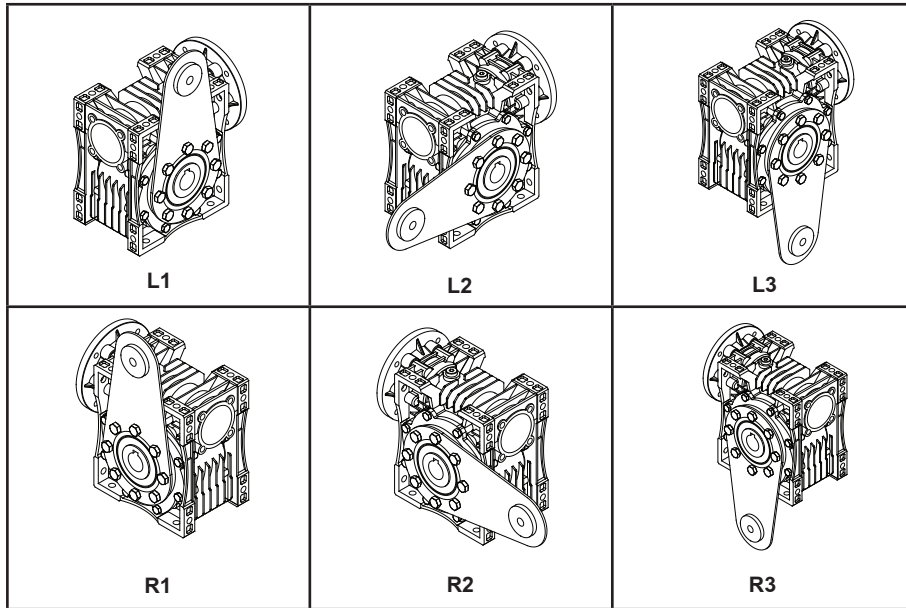



# Ölçü Sayfaları

## Dimension Pages

### Abmessungsseiten

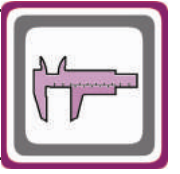

Opsiyonel olarak yapılabilir delik mil ölçüleri / Alternative hollow shaft dimensions / Sonder-Hohlwellenmaßen

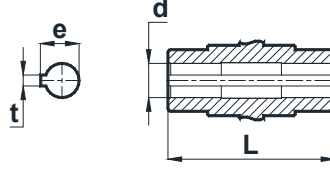

Tipi Type Typ	Mil Ölçüleri Shaft Dimensions Wellenmaße			
	d (H7)	e	t	L
EN030.X0	14	16,3	5	66
EN040.X0	14	16,30	5	82
	18(Std)	20,80	6	
	19	21,80	6	
EN050.X0	20	22,80	6	98
	18	20,80	6	
	19	21,80	6	
	20	22,80	6	
EN063.X0	24	27,30	8	122
	25(Std)	28,30	8	
	28	31,30	8	
	30	33,30	8	
	25	28,30	8	
EN075.X0	28	31,30	8	120
	30	33,30	8	
	32	35,30	10	
	35(Std)	38,30	10	
	28	31,30	8	
EN080.X0	35(Std)	38,30	10	133
	30	33,30	8	
	32	35,30	10	
	28	31,30	8	
	25	28,30	8	
EN100.X0	42(Std)	45,30	12	156
	40	43,30	12	
	38	41,30	10	
	35	38,30	10	
	50	53,80	14	
	45	48,80	14	
EN125.X0	60	64,40	18	185
	50	53,80	14	
	45(Std)	48,80	14	
	40	43,30	12	
	35	38,30	10	



# Ölçü Sayfaları Dimension Pages Abmessungsseiten

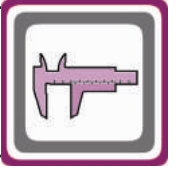

**SONSUZ TİP REDÜKTÖRLERDE TAVSİYE EDİLEN MİL BOYU MONTAJ-DEMONTAJ ŞEKLİ VE AKSESUARLARI**  
**ADVISED SHAFT DIMENSIONS AND ACCESSORIES USED BY ASSEMBLING WORM GEAR TYPE GEARBOXES**  
**EMPFOHLENE WELLEN MASSEN UND VERBINDUNGSELEMENTE BEI MONTAGE FÜR SCHNECKENGETRIEBE**

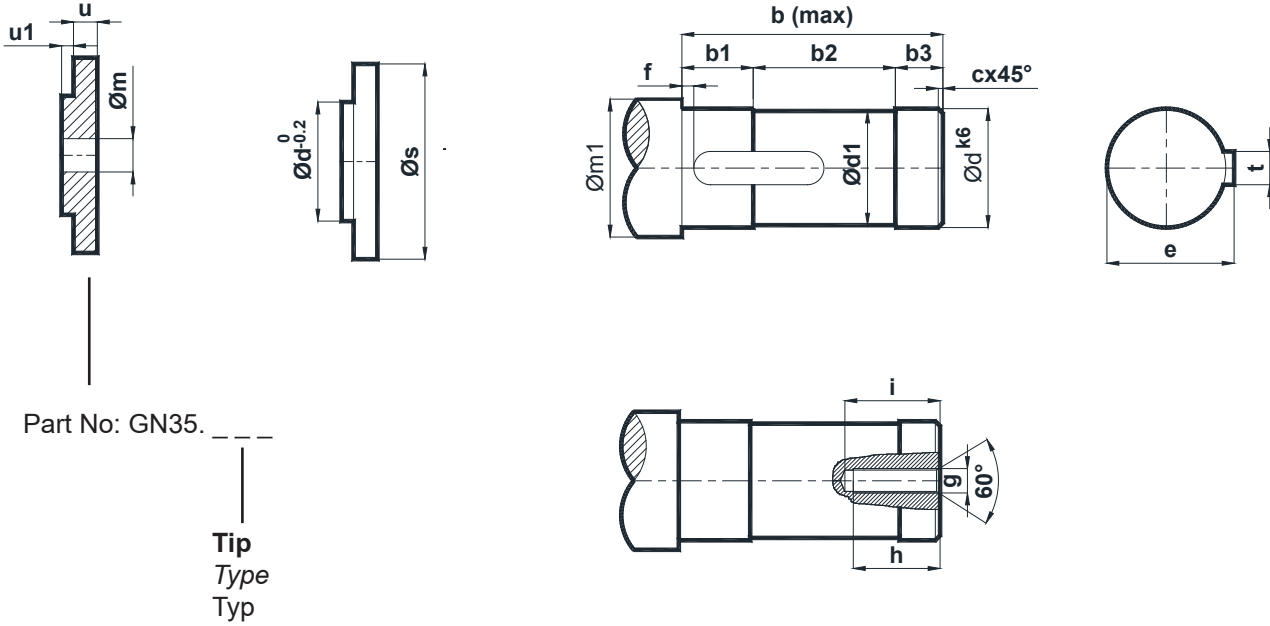

Örnek : GN35.E040

Tip Type Typ	s	m	u	u1	t	e	d	d1	b	b1	b2	b3	c	m1	f	h	i	g	y
E..030	18	6	3	2,5	5	16	14	13	63	24,5	17	21,5	0,5	19,5	5	14,5	17	M5	M5x20
E..040	24	6	3	2,5	6	20,5	18	17	79	20	42	17	1	24,5		14,5	17	M5	M6x25
E..050	34	11	5	3,5	8	28	25	24	93,5	28	42	23,5	1	33		24	30	M10	M10x30
E..063	34	11	5	3,5	+8	28	25	24	117,5	36	50	31,5	1	33		24	30	M10	M10x30
E..075	44	13	6	3,5	10	38	35	34	115,5	43	34	38,5	1	42		30	37	M12	M12x40
E..080	44	13	6	3,5	10	38	35	34	128,5	46	41	41,5	1	42		30	37	M12	M12x40
E..100	54	17	6	3,5	12	45	42	41	151,5	52	52	47,5	1,5	49		38	45	M16	M16x45
E..125	54	17	8	3,5	14	48,5	45	44	180,5	66	53	61,5	2	54		38	45	M16	M16x45

Çektirme / Dismounting / Einziehen

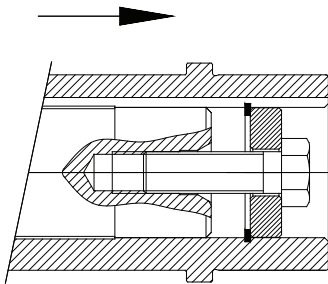

Montaj / Mounting / Befestigen

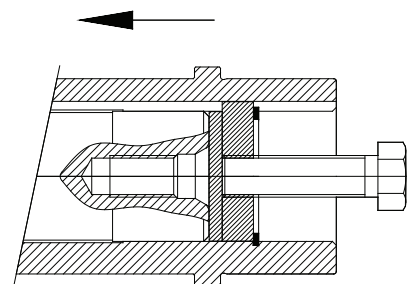

**6 Köşe Başlı Civata / 6 Contour Bolt / Sechskantschraube**  
(DIN ISO 4014 . DIN ISO 4017)  
(DIN ISO 8765)

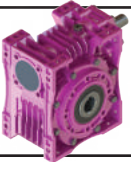

## Ölçü Sayfaları Dimension Pages Abmessungenseiten

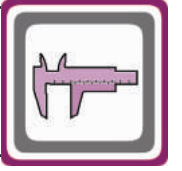

Mil Muhafaza Kapağı / Shaft Protection Cover / Wellenversteckdeckel

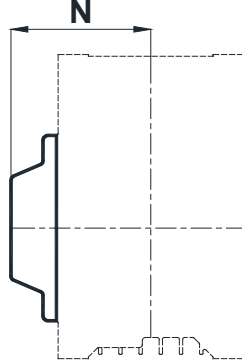

Tipi Type Typ	N
<b>E.030</b>	46,5
<b>E.040</b>	57,5
<b>E.050</b>	65,5
<b>E.063</b>	83
<b>E.075</b>	90
<b>E.080</b>	93
<b>E.100</b>	108
<b>E.125</b>	128,5