

# İçindekiler

## Index

### Inhaltsverzeichnis



<b>Genel Bilgiler</b> <i>General Info.</i> Einführung	<b>Sembollerin Açıklaması</b>	<i>Key of Symbols</i>	Erklärung der Bezeichnungen	
	<b>Ürün Yelpazesi</b>	<i>Production Range</i>	Produktpalette	04
	<b>K Serisi Redüktörlerin Genel Özellikleri</b>	<i>General Specifications of K Series Gearboxes</i>	Allgemeine Eigenschaften Von K Serie Getrieben	06
	<b>Teknik Tanımlamalar</b>	<i>Technical Explanations</i>	Technische Erläuterungen	07
	<b>Teknik Özellikler</b>	<i>Technical Specifications</i>	Technische Informationen	07
	<b>Aksesuarlar</b>	<i>Accessories</i>	Zubehör	08
	<b>Tip Tanımlaması</b>	<i>Unit Designation</i>	Typenbezeichnungen	10
	<b>Örnek Tip Tanımlamaları</b>	<i>Sample Designations</i>	Typenbezeichnungsbeispiele	13
	<b>Motor Büyüklüğüne Göre Geometrik Mümkün Çevrim Oranı Komb. Servis Faktörü</b>	<i>Geomet. Possible Combinations of Ratios According to Motor Size</i>	Geomet. Mögliche Kombi. von Übersetz. nach Motorbaugröße	14
	<b>Yük Sınıflandırması</b>	<i>Service Factor</i>	Betriebsfaktor	16
	<b>Redüktör Dönüş Yönleri</b>	<i>Load Classification</i>	Belastungsart	17
	<b>Radyal Yükler</b>	<i>Direction of Rotation</i>	Getriebedrehrichtungen	19
	<b>Radyal Yüklerin Hesabı</b>	<i>Overhung Loads</i>	Querkräfte	20
	<b>Ekstruder Tiplerde Müsade Edilebilir Eksenel Yükler</b>	<i>Calculation Of Overhung Loads</i>	Berechnung der Querkräfte	21
	<b>Eşdeğer Güç Hesabı</b>	<i>Permissible Axial Loads for Extruder Types</i>	Zulässige Axialkräfte für Extruder Typ Getrieben	22
	<b>Eşdeğer Güç Hesabı Örneği</b>	<i>Equivalent Power Calculation</i>	Äquivalente Leistung	24
	<b>Redüktör Seçimi</b>	<i>Equivalent Power Cal. Example</i>	Beispiel für Äquivalente Leistung	25
	<b>Redüktör Seçim Formu</b>	<i>Gearbox Selection</i>	Getriebeauswahl	26
	<b>Yağlama</b>	<i>Gearbox Selection Form</i>	Formular für Getriebeauswahl	28
	<b>Yağ Tipleri</b>	<i>Lubrication</i>	Schmierung	32
	<b>Montaj Pozisyonları</b>	<i>Oil Types</i>	Schmierstoffe	33
	<b>Yağ Tapaları</b>	<i>Mounting Positions</i>	Bauformen	34
	<b>Yağ Miktarları</b>	<i>Oil plugs</i>	Ölverschlussschrauben	35
	<b>Motorlar</b> <i>Motors</i> Motor	<i>Oil Quantities</i>	Ölmengen Tabellen	35
	<b>AC Motorlar</b>	<i>AC Motors</i>	Drehstrommotoren	39
	<b>a- Genel Özellikler</b>	<i>a- General Spec. of AC Motors</i>	a-Eigensch. des Drehstrommotors	39
	<b>b- Çalışma Türleri</b>	<i>b-Modes of Operation</i>	b-Betriebsarten	40
	<b>c- Koruma Sınıfı</b>	<i>c- Protection Class</i>	c- Schutzarten	41
	<b>d- İzolasyon Sınıfı</b>	<i>d- Insulation Class</i>	d- Isolationsklasse	41
	<b>e- Verim Sınıfları</b>	<i>e- Efficiency Classes</i>	e- Energieeffizienzklassen	41

K0701-0613

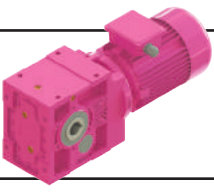

# İçindekiler

## Index

### Inhaltsverzeichnis



<b>Motorlar</b> <i>Motors</i> Motor	<b>f- AC Frekans İntertörler</b>	<i>f- AC Frequency Inverters</i>	f- AC Frequenz Umrichter	42
	<b>DC Motorlar</b>	<i>DC Motors</i>	DC Motoren	
	<b>a- Genel Özellikler</b>	<i>a- General Specif. of DC Motors</i>	a- Eigenschaften von DC Motoren	43
	<b>b- DC Motorların Çalışma İlkeleri</b>	<i>b- Operating principals of DC Motors</i>	b- Funktionsprinzip der DC Motoren	43
	<b>c- DC Motor Çeşitleri</b>	<i>c- Types of DC Motors</i>	c- Arten von DC Motoren	43
	<b>d- DC Motorlarda Hız Kontr.</b>	<i>d- Speed Control of DC motors</i>	d- Drehzahl Kontrolle DC Motoren	43
<b>Frenler</b> <i>Brakes</i> Bremsen	<b>Elektromanyetik Frenler</b>	<i>Electromagnetic Brakes</i>	Elektromagnetische Bremsen	44
	<b>Fren Çeşitleri</b>	<i>Brake Types</i>	Bremsenarten	45
	<b>Fren Bağlantı Şekli</b>	<i>Connection Types</i>	Schaltungsarten	46
	<b>Fren Seçimi</b>	<i>Brake Selection</i>	Bremswahl	46
	<b>Frenin Termik Kapasitesi</b>	<i>The Thermal Capacity of Brake</i>	Therm. Kapazität der Bremsen	47
<b>Güç Devir Tabl.</b> <i>Perform. Tables</i> Leistung-Drehzahl Tabellen.	<b>Motorlu Güç Devir Tabloları</b>	<i>Geared Motors Performance Tables</i>	Getriebeleistung und Drehzahl Übersicht	49
	<b>Motorsuz Güç Devir Tabloları</b>	<i>Gear Units Performance Tables</i>	Getriebe Leistung und Drehzahl-übersicht	363
<b>Ölçü Sayfaları</b> <i>Dimension Pages</i> Abmessungen Tabellen	<b>KR serileri</b>	<i>KR series</i>	KR serie	85
	<b>KN serileri</b>	<i>KN series</i>	KN serie	178
	<b>KV serileri</b>	<i>KV series</i>	KV serie	270
	<b>KT serileri</b>	<i>KT series</i>	KT serie	373
<b>Mil ve Kovan Ölçüleri</b> <i>Shaft and Hollow Shaft Dimensions</i> Wellen und Gehäusemaße	<b>K....0E Ekstruder Boğazlı Redüktörler</b>	<i>K....0E Extruder Type Gearboxes</i>	K....0E Extruder Getriebe von K Serie	466
	<b>K....0S Sıkma Bilezikli Redüktörler</b>	<i>K....0S Gearboxes with Shrink Disk Connector</i>	K....0S Serie Hohwelle mit Schrumpfscheibe	470
	<b>K serisi Kovan Ölçüleri</b>	<i>K series Hollow Shaft Dimensions</i>	Gehäuseabmessungen von K Serie Getriebe	471
	<b>Moment Kollu Redüktörler</b>	<i>Gearboxes with Torque Arm</i>	Drehmomentstütze Montagezeichnungen	471
	<b>K Serisi Redüktörler için Montaj Önerileri</b>	<i>Mounting Advices for Hollow Shaft Gearboxes</i>	Montagevorschläge Für D Serie Getriebe	473

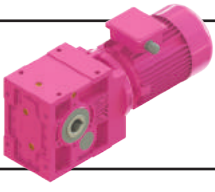

# Genel Bilgiler

## General Information

### Einführung



#### Sembollerin Açıklaması

$c_t$ .....: Anahtarın devreye girme zamanı katsayısı

$f_s$ .....: Servis faktörü

$F_{ama}$ .....: Çıkış milinde müsaade edilen eksenel yükler [kN]

$F_{ame}$ .....: Giriş milinde müsaade edilen eksenel yükler [kN]

$F_{qam}$ .....: Çıkış milinde izin verilen radyal yükler [N]

$F_{qem}$ .....: Giriş milinde izin verilen radyal yükler [N]

$F_{qa}$ .....: Çıkış miline gelen radyal yükler [N]

$F_{qe}$ .....: Giriş miline gelen radyal yükler [N]

$F_q$ .....: Radyal yönde çıkış miline gelen yükler [N]

$F_a$ .....: Eksenel yönde çıkış miline gelen yükler [N]

$i$ .....: Tahvil oranı

$J_{ext}$ .....: Motor miline indirgenmiş toplam dış atalet momenti [kgm<sup>2</sup>]

$M_2$ .....: Çıkış momenti [Nm]

$M_a$ .....: Anma momenti [Nm]

$n_1$ .....: Redüktör giriş mili devri [d/dak]

$n_2$ .....: Redüktör çıkış mili devri [d/dak]

$P_{eq}$ .....: Eşdeğer güç [kW]

$P_e$ .....: Nominal güç (Bak. Güç-Devir Tabloları) [kW]

$P_M$ .....: Tahrik edilecek makina için gerekli güç (Değişken yükler için eşdeğer güç alınır) [kW]

$t$ .....: Zaman [s]

$T_e$ .....: Eşdeğer moment [Nm]

#### Key of Symbols

$c_t$ .....: Coefficient of switch on time.

$f_s$ .....: Service factor

$F_{ama}$ .....: Permissible axial loads which can be applied to output shafts [kN]

$F_{ame}$ .....: Permissible axial loads which can be applied to input shafts [kN]

$F_{qam}$ .....: Permissible overhung loads which can be applied to output shafts [N]

$F_{qem}$ .....: Permissible overhung loads which can be applied to input shafts [N]

$F_{qa}$ .....: Overhung loads applied to the output shaft [N]

$F_{qe}$ .....: Overhung loads applied to the input shafts [N]

$F_q$ .....: Overhung loads on output shaft [N]

$F_a$ .....: Axial loads on output shaft [N]

$i$ .....: Transmission ratio

$J_{ext}$ .....: Total outside moment of inertia reduced to the motor shaft [kgm<sup>2</sup>]

$M_2$ .....: Output torque [N]

$M_a$ .....: Nominal torque [Nm]

$n_1$ .....: Input speed of gearbox [rpm]

$n_2$ .....: Output speed of gearbox [rpm]

$P_e$ .....: Equivalent power [kW]

$P_N$ .....: Nominal power (given on performance tables) [kW]

$P_M$ .....: Power consumption of the driven machine (for alternating power, refer to equivalent power) [kW]

$t$ .....: Time [s]

$T_e$ .....: Equivalent torque [Nm]

#### Erklärung der Bezeichnungen

$c_t$ .....: Koeffizient der Betätigung von Schalter

$f_s$ .....: Betriebsfaktor

$F_{ama}$ .....: Zulässige Axialkräfte auf Abtriebswelle [kN]

$F_{ame}$ .....: Zulässige Axialkräfte auf Antriebswelle [kN]

$F_{qam}$ .....: Zulässige Querkräfte auf Abtriebswelle [N]

$F_{qem}$ .....: Zulässige Querkräfte auf Antriebswelle [N]

$F_{qa}$ .....: Querkräfte auf Abtriebswelle [N]

$F_{qe}$ .....: Querkräfte auf Antriebswelle [N]

$F_q$ .....: Querkräfte auf Abtriebswelle [N]

$F_a$ .....: Axialkräfte auf Abtriebswelle [N]

$i$ .....: Übersetzungsverhältnis

$J_{ext}$ .....: Die Gesamtträgheit der rotierende Teile von der Ausgangsseite reduziert auf Motorwelle [kgm<sup>2</sup>]

$M_2$ .....: Ausgangsdrehmoment [N]

$M_a$ .....: Nenndrehmoment [Nm]

$n_1$ .....: Antriebsdrehzahl [U/min]

$n_2$ .....: Abtriebsdrehzahl [U/min]

$P_e$ .....: Äquivalente Leistung [kW]

$P_N$ .....: Getriebe Nennleistung (siehe Leistung- Drehzahl tabellen) [kW]

$P_M$ .....: Benötigte Leistung an der Abtriebswelle (Zur Berechnung bei variablen Leistungen äquivalente Leistung benutzen) [kW]

$t$ .....: Zeit [s]

$T_e$ .....: Minimales Drehmoment [Nm]

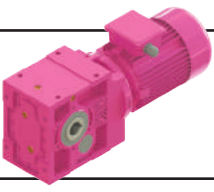

# Genel Bilgiler

## General Information

### Einführung



#### Ürün Yelpazesi

Elinizdeki katalog sadece **K serisi** ürünleri içermektedir.

##### - M ve N Serisi

Helisel alın dişliye sahip, giriş ve çıkış milleri aynı düzlem üzerinde ve birbirine paralel uzanan, üzerlerinde bulunan ayak veya flanş ile makina-ya sabitlenen redüktörlerdir. Dolu mil çıkışlıdır.

##### - D Serisi

Helisel alın dişliye sahip, giriş ve çıkış milleri aynı düzlem üzerinde, birbirine paralel ve belirli bir aralıkta yerleştirilmiş, iki yan yüzde bulunan bağlantı civataları, flanş veya tork kolu ile makina-ya sabitlenen redüktörlerdir. Delik milli veya mil çıkışlı olabilir.

##### - E Serisi

Sonsuz vida ve çark dişlili, belirli bir aralıkta ve birbirine dik konumlandırılmış giriş ve çıkış millerine sahip, çepçevre konumlandırılmış ayak bağlantıları, flanş veya tork kolu ile makina-ya sabitlenebilen redüktörlerdir. Delik milli veya mil çıkışlı olabilir.

##### - Y Serisi

Yatık tip redüktörler, ağır şartlarda çalışmak üzere dizayn edilmiş redüktör tipleridir. Bu tiplerde redüktör ile bunu tahrik eden mekanizma arasında değişik bağlantı şekilleri mevcuttur (Mekanik ve hidrolik kaplinler, çeşitli tip kayışlar ve zincirle tahrik gibi). Delik milli veya mil çıkışlı olabilir.

##### - K Serisi

Helisel alın dişli ve konik dişlilerden oluşan, birbirine dik ve belirli bir aralıkta konumlandırılmış giriş ve çıkış miline sahip, çepçevre sunulan ayaklar, flanş veya tork kolu ile makina-ya sabitlenen redüktörlerdir. E serisinden farklı olarak yüksek verime sahiptirler. Delik milli veya mil çıkışlı olabilir.

##### - H ve B Serisi

Helisel ve/veya konik dişliye sahip ağır hizmet tipi redüktörlerdir. Giriş ve çıkış milleri birbirine paralel veya dik olabilir. Her yönden bağlantı için ayak bağlantıları bulunur. Opsiyonel olarak flanş ile de bağlanabilir. Delik milli veya mil çıkışlı olabilir.

##### - T Serisi

T Serisi redüktörler helisel dişli iki kademe motorsuz delik milli redüktörlerdir. T Serisi redüktörler delik milli olması ve kompakt gövde yapısı sayesinde daha küçük hacimli alanlara montajı yapılabilmektedir.

##### - P ve R Serisi

P ve R Serisi redüktörler planet dişli redüktörlerdir. Endüstriyel ve mobil uygulamalarda kullanılırlar. Diğer redüktör tiplerine göre daha küçük hacimde daha büyük tork iletebilirler.

##### - V Serisi

V vinç redüktörleri M1 - M8 (1Dm - 5m) vinç sınıflarına uygun olarak, çift veya sabit devirli frenli motorlarla üretilebilmektedir.

#### Production Range

*This catalogue is containing K series of gearboxes only.*

##### - M and N Series

*M and N series are helical geared gear units. The input and output shafts are parallel to each other and on the same plane. The gearbox can be connected to the machine by using the foot or flange on the gearbox. Has solid output shaft.*

##### - D Series

*D series are helical geared gearboxes with parallel input and output shafts. The shafts have a distance in between and located on the same plane. The gearbox can be assembled to the machine by using, the connection screws on the sides, flange or torque arm on the gearbox. Can have hollow or solid output shaft.*

##### - E Series

*E series gearboxes are with worm and worm-wheel. The input and output shafts are perpendicular to each other and have a distance in between. It can be assembled to the driven machine by the use of the foot, flange or torque arm on the gearbox. Can have hollow or solid output shaft.*

##### - Y Series

*Horizontal type gearboxes are designed to operate in heavy conditions. In these types there are a lot of combination forms between gearbox and driver (for example, mechanic and hydraulic couplings, various belt and chain drives etc.). Can have hollow or solid output shaft.*

##### - K Series

*These are gearboxes with helical and bevel gears. The input and output shafts are perpendicular to each other and have a distance in between. It can be assembled to the driven machine using the foot, flange or torque arm on the gearbox. They have high efficiency compared to E series. Can have hollow or solid output shaft.*

##### - H and B Series

*These gearboxes are helical or/and bevel geared industrial gearboxes. The input and output shafts can be arranged parallel or perpendicular to each other. The gearbox can be assembled by the use of the foot connections on each side. Flange connections are optional. They can have hollow or solid output shaft.*

##### - T Series

*T Series are gear units which are helical geared, two staged, hollow shaft mounted gear units and manufactured according to monoblock principal. T Series gearboxes have hollow shaft and compact housing so that T series can be mounted on smaller places.*

##### - P and R Series

*P and R Series gearboxes are planetary gearboxes. They are mostly used by industrial and mobile applications. Planetary gearboxes can transfer high torques in small volumes compared to other gearboxes.*

##### - V Series

*V hoist drives are produced according to M1 - M8 (1Dm - 5m) crane classes.*

#### Produktpalette

Dieses Katalog umfasst nur die **K Serie** Getriebe.

##### - M und N Serie

Diese Modelle sind Stirnradgetriebe mit parallelen Antriebs- und Abtriebswelle auf einer Ebene. Die Getriebe werden mit Fuß- oder Flanschverbindung an die angetriebene Maschine angekoppelt. Hat Vollwelle am Ausgang.

##### - D Serie

Diese Getriebe sind Stirnradgetriebe mit paralleler Antriebs- und Abtriebswelle, die auf einer Ebene liegen und einen Abstand zueinander haben. Diese Getriebe wird seitlich mit Gewindelöchern am Maschine oder mit einer Flansch verbindet. Kann Voll- und Hohlwelle am Ausgang haben.

##### - E Serie

Diese Getriebe bestehen aus Schnecke und Schneckenrad. Die Antriebs- und Abtriebswellen sind senkrecht zueinander und haben einen bestimmten Abstand. Das Getriebe wird mit Fußbefestigung, Flanschverbindung oder mit Drehmomentstütze an die angetriebene Maschine montiert. Kann Voll- und Hohlwelle am Ausgang haben.

##### - Y Serie

Diese Getriebe sind für Einsatz unter schweren Bedingungen ausgelegt. Bei dieser Ausführung gibt es sehr viele verschiedene Verbindungsmöglichkeiten zwischen Antrieb und Getriebe (Zum Beispiel; mechanische und hydraulische Kupplungen, Riemtrieb, Kettentrieb usw.). Kann Voll- und Hohlwelle am Ausgang haben.

##### - K Serie

Diese Getriebe bestehen aus Stirnräder und Kegelräder. Die Antrieb und Abtriebswellen sind senkrecht und haben einen Abstand zueinander. Das Getriebe wird mit Fußbefestigung, Flanschverbindung oder Drehmomentstütze an die angetriebene Maschine montiert. Der Wirkungsgrad ist wesentlich höher als E Serie. Kann Voll- und Hohlwelle am Ausgang haben.

##### - H und B Serie

Diese Getriebe sind geeignet für industrielle Anwendungen und haben parallelen oder senkrechten Antrieb und Abtriebswelle auf einer Ebene. Das Getriebe kann mit Füßen, die auf jede Seite der Getriebe vorhanden sind, oder optional mit Flansch an die angetriebene Maschine montiert werden. Kann Voll- und Hohlwelle am Ausgang haben.

##### - T Serie

T Serien Getriebe sind zwei stufige, schrägverzahnte Hohlwellenflachgetriebe in Monoblockgehäuse. Die T Serie hat eine kompakte Gehäuse und ist serienmäßig mit Abgangshohlwelle hergestellt, so dass das Getriebe minimalen Platzbedarf hat.

##### - P und R Serie

P und R Serie sind Planetengetriebe, die vielseitig im Industrie und bei mobiler Anwendungen einsetzbar sind, mit Planetenzahnräder. Planetengetriebe können im Vergleich zu anderen Getrieben größere Drehmomente bei kleineren Bauvolumen übertragen.

##### - V Serie

V Krane und Hebezeuge werden geeignet zur Kranklasse M1 - M8 (1Dm - 5m) hergestellt.

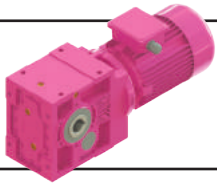

# Genel Bilgiler

## General Information

### Einführung



M ...

**13 farklı büyüklükte;**  
**Moment aralığı: 50 - 18.000 Nm**  
**Devir aralığı: 0,1 - 500 d/dak**  
13 different sizes:  
Torque range: 50 - 18.000 Nm  
Speed range: 0,1 - 500 rpm  
13 verschiedene Baugrößen:  
Drehmomentbereich: 50 - 18.000 Nm  
Drehzahlbereich : 0,1 - 500 U/min



N ...

**13 farklı büyüklükte;**  
**Moment aralığı: 50 - 18.000 Nm**  
**Devir aralığı: 0,1 - 500 d/dak**  
13 different sizes:  
Torque range: 50 - 18.000 Nm  
Speed range: 0,1 - 500 rpm  
13 verschiedene Baugrößen:  
Drehmomentbereich: 50 - 18.000 Nm  
Drehzahlbereich : 0,1 - 500 U/min



E ...

**8 farklı büyüklükte;**  
**Moment aralığı: 5 - 1.000 Nm**  
**Devir aralığı: 0,1 - 400 d/dak**  
8 different sizes:  
Torque range: 5 - 1.000 Nm  
Speed range: 0,1 - 400 rpm  
8 verschiedene Baugrößen:  
Drehmomentbereich: 5-1.000 Nm  
Drehzahlbereich : 0,1-400 U/min



K ...

**10 farklı büyüklükte;**  
**Moment aralığı: 80 - 15.000 Nm**  
**Devir aralığı: 0,1 - 400 d/dak**  
10 different sizes:  
Torque range: 80 - 15.000 Nm  
Speed range: 0,1 - 400 rpm  
10 verschiedene Baugrößen:  
Drehmomentbereich: 80 - 15.000 Nm  
Drehzahlbereich : 0,1 - 400 U/min



D ...

**10 farklı büyüklükte;**  
**Moment aralığı: 130 - 18.000 Nm**  
**Devir aralığı: 0,1 - 350 d/dak**  
10 different sizes:  
Torque range: 130 - 18.000 Nm  
Speed range: 0,1 - 350 rpm  
10 verschiedene Baugrößen:  
Drehmomentbereich: 130 - 18.000 Nm  
Drehzahlbereich : 0,1 - 350 U/min



Y ...

**25 farklı büyüklükte;**  
**Moment aralığı: 1200 - 43000 Nm**  
**Devir aralığı: 2,6 - 990 d/dak**  
25 different sizes:  
Torque range: 1200 - 43000 Nm  
Speed range: 2,6 - 990 rpm  
25 verschiedene Baugrößen:  
Drehmomentber. :1200-43000 Nm  
Drehzahlbereich : 2,6-990 U/min



H ...

**13 farklı büyüklükte;**  
**Moment aralığı: 2.500 - 150.000 Nm**  
**Devir aralığı: 0,1 - 250 d/dak**  
13 different sizes:  
Torque range: 2.500 - 150.000 Nm  
Speed range: 0,1 - 250 rpm  
13 verschiedene Baugrößen:  
Drehmomentber. :2.500 - 150.000 Nm  
Drehzahlbereich : 0,1 - 250 U/min



B ...

**13 farklı büyüklükte;**  
**Moment aralığı: 5.000 - 150.000 Nm**  
**Devir aralığı: 0,1 - 115 d/dak**  
13 different sizes:  
Torque range: 5.000 - 150.000 Nm  
Speed range: 0,1 - 115 rpm  
13 verschiedene Baugrößen:  
Drehmomentber. :5.000-150.000 Nm  
Drehzahlbereich : 0,1-115 U/min



P ...

**10 farklı büyüklükte;**  
**Moment aralığı: 1.000 - 50.000 Nm**  
**Tahvil oranları: 3,5 - 3000 arası**  
10 different sizes:  
Torque range: 1.000 - 50.000 Nm  
Transmission ratio: 3,5 - 3000  
10 verschiedene Baugrößen:  
Drehmomentber. : 1.000 - 50.000 Nm  
Übersetzung: 3,5 - 3000



R ...

**10 farklı büyüklükte;**  
**Moment aralığı: 1.000 - 50.000 Nm**  
**Tahvil oranları: 3,5 - 3000 arası**  
10 different sizes:  
Torque range: 1.000 - 50.000 Nm  
Transmission ratio: 3,5 - 3000  
10 verschiedene Baugrößen:  
Drehmomentber. : 1.000 - 50.000 Nm  
Übersetzung: 3,5 - 3000



T ...

**10 farklı büyüklükte;**  
**Moment aralığı: 200 - 18.000 Nm**  
**Devir aralığı: 46 - 280 d/dak**  
10 different sizes:  
Torque range: 200-18.000 Nm  
Speed range: 46-280 rpm  
10 verschiedene Baugrößen:  
Drehmomentber. :200-18.000 Nm  
Drehzahlbereich : 46-280 U/min



V ...

**5 farklı büyüklükte;**  
**M1 - M8 ,(1Dm - 5m) vinç sınıfları**  
**ISO 4301 / 1 ,(FEM 9.511/86)**  
5 different sizes  
M1 - M8 ,(1Dm - 5m) crane classes  
ISO 4301 / 1 ,(FEM 9.511 / 86)  
5 verschiedene Baugrößen  
M1 - M8 ,(1Dm - 5m) Kranklasse  
ISO 4301 / 1 ,(FEM 9.511 / 86)

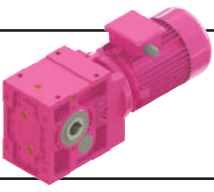

# Genel Bilgiler

## General Information

### Einführung



#### K Serisi Redüktörlerin Genel Özellikleri

K Serisi redüktörler, helisel konik dişli monoblok gövde yapısındaki redüktörlerdir. Giriş ve çıkış milleri 90° olması gereken durumlarda yüksek verim ve mukavemetin gerektirdiği yerler için dizayn edilmiştir.

K Serisi redüktörler E serisinin çok yönlü bağlantı opsiyonları ile M serisinin monoblok ve yüksek verim özellikleriyle birlikte yüksek momente sahip olarak üretilmektedir. Redüktörlerin giriş motor bağlantılarında IEC B5 veya B14, standart akuple veya motorsuz mil girişli gibi esnek montaj opsiyonları kullanılmaktadır.

K serisi redüktörler monoblok gövde içerisinde; küçük gövdeler 2 ve 3 kademe, büyük gövdeler 3 kademe olarak üretilmektedir. Yüksek redüksiyon gerektiren yerlerde 6 kademeye kadar akuple edilerek temin edilebilir.

YILMAZ REDÜKTÖR olarak tasarım prensibimiz;

- Yüksek teknoloji kullanmak
- Güvenilirlik,
- Yüksek güç yoğunluğu,
- Yüksek verim,
- Montaj uyumluluğu,
- Esnek çözümler

#### Dikkat Edilecek Hususlar !

- Bu katalogta verilen resimler görsel amaçlıdır ve şekilsel detaylar bağlayıcı değildir.

- YILMAZ REDÜKTÖR, ürünler ve kataloglar üzerinde, müşterileri bilgilendirmeksizin her türlü değişikliği yapma hakkına sahiptir.

- Ürünler teslim alındıktan sonra ürünle birlikte verilen kullanım kılavuzu okunmadan sistem devreye alınmamalıdır.

- Katalogta verilen yağ miktarları referans amaçlıdır. Gerçek yağ seviyesi için redüktör üzerinde bulunan yağ seviye tapası kullanılmalıdır. Yağ viskozitesi için, redüktör etiketine bakınız.

- Sipariş anında montaj pozisyonu bildirilmeyen redüktörler **M1** montajına uygun sevk edilir. Etiketle yazan montaj pozisyonundan farklı bağlanan redüktörler garanti kapsamından çıkar. Bu katalogta verilen redüktör ağırlıkları ortalama ağırlık değerleridir. Tahvil oranına ve üzerinde bağlı olan aksesuara göre ağırlıklar farklılık gösterebilir.

#### General Specifications of K Series Gearboxes

*K Series gearboxes are helical-bevel geared monoblock housing gearboxes. K Series are designed for higher efficiency and higher strenght required operations. Input and output shafts are perpendicular to each other.*

*K Series gearboxes have advantages of E Series mounting options, monoblock housing and higher efficiency advantages of M series with higher torque capabilities. K Series have flexible connection possibilities which is IEC B5 or B14 connection, directly mounted or solid input shaft options .*

*Small sizes of K series gearboxes can be 2 and 3 stages. Bigger sizes are manufactured only 3 stages in monoblock housing. K series supplied for high reduction operations up to 6 stages by using double housings.*

*As we are YILMAZ REDÜKTÖR,our design principals are;*

- Using high technology
- Reliability
- High power density
- High efficiency
- Mounting compatible
- Flexible solutions

#### Attention to the following points !

*- Drawings are examples only and the details on the drawings or illustrations are not strictly binding.*

*- YILMAZ REDÜKTÖR reserve the right to make all kinds of changes in products and catalogues without any notice.*

*- Prior to commissioning, the operating instructions provided with the gearbox must be observed.*

*- Oil quantities given are guide values only. The exact quantity of oil should be checked by using the provided oil level plugs according mounting positions. For correct oil viscosity refer to the nameplate.*

*- If the mounting position is not informed upon ordering, the gear unit is delivered according **M1** mounting position. A different operation then the indicated mounting position on the name plate cancels the warranty. The weights given in this catalogue are mean values. Depending on the ratio and accessories the weights can differ.*

#### Allgemeine Eigenschaften von K Serie Getrieben

K Serie Getriebe sind Kegelaradgetriebe mit Monoblok-Gehäuse. Eingang- und Ausgangswelle sind senkrecht zueinander. Diese Getriebe sind für Einsätze, wo hohe Wirkungsgrad und Festigkeit benötigt wird, konstruiert.

K Serie Getriebe haben umfangreiche Montagemöglichkeiten, wie E Serie, hohe Momenttragbarkeit mit hohem Wirkungsgrad und Monoblok-Gehäuse, wie M Serie, als Vorteil. Standart Motorverbindung (IEC B14 oder B5) oder Wellenantrieb ist möglich.

Kegelradgetriebe können nur maximal mit 3 Stufen in einem Gehäuse hergestellt werden. K Serie Getriebe werden für hohe Untersetzungen mit Hilfe von zusätzlichem Gehäuse bis zu 6 Stufen ausgeführt.????????????????

Als YILMAZ REDÜKTÖR unsere Entwurfsprinzipien sind;

- Verwenden von hohen Fertigungstech.
- Hohe Betriebssicherheit
- Leistungsdichte
- Hoher Wirkungsgrad
- Universale Montagemöglichkeit
- Sonderlösungen

#### Bitte folgende Punkte beachten !

- Die Abbildungen sind beispielhaft und nicht verbindlich.

- Alle-Änderungen auf dem Katalog und an der Produkte bleiben vorbehalten und können ohne Kenntnisnahme erfolgen.

- Vor Inbetriebnahme ist die mit gelieferter Betriebsanleitung zu beachten.

-Angaben über Ölmengen sind unverbindlich. Maßgebend ist die Ölstandsschraube in der geeigneten Montageposition. Ölviskosität und Sorte muss den Angaben des Typenschildes entsprechen.

- Wenn die Bauform bei Bestellung nicht angegeben ist, erfolgt die Lieferung in der Bauform **M1**. Wenn die Getriebe anders als auf dem Typenschild benannte Bauform eingesetzt werden, verliert die Garantie ihre Gültigkeit. Die angegebenen Gewichte sind unverbindliche Mittelwerte ohne Zubehör; genauere Gewichte sind abhängig von Zubehör und Übersetzung.

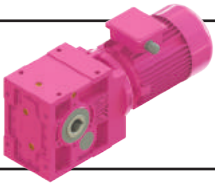

# Genel Bilgiler

## General Information

### Einführung



#### Teknik Tanımlamalar

##### - Çıkış Momenti ( $M_2$ ): [Nm]

Motorun verdiği momentin tahvil oranı ve verimle ile çarpılarak elde edilen değerdir. Redüktörün çıkışından alınabilecek moment gösterir.

##### - Anma Momenti ( $M_a$ ): [Nm]

Redüktörün  $f_s=1$  şartı için mekanik olarak taşıdığı moment değeridir.

##### - Nominal Güç ( $P_e$ ): [kW]

Nominal güç, redüktörün  $f_s=1$  şartı için mekanik olarak taşıyabileceği güç değeridir. Redüktörlerin nominal güçleri, güç devir tablolarında verilmiştir.

##### - Çevrim oranı (i):

Redüktörün giriş devrinin çıkış devrine oranıdır. Yılmaz Redüktör M serisi redüktörlerde 3,5-23500 arasında değişen çevrim oranları mevcuttur.

##### - Eşdeğer Güç ve Moment

$P_{eq}$  [kW],  $T_e$  [Nm]

Sabit devir altında ancak değişken yük değerlerinde çalışan redüktörlerde, sabit yük altında çalışma şartlarına eşdeğer gelen moment ve güç değerleridir. Hesaplama yöntemi sayfa 23'de verilmiştir.

##### - İhtiyaç güç ( $P_M$ ): [kW]

Redüktörlerin kullanılacağı uygulamanın istenilen şekilde çalışabilmesi için ihtiyaç duyduğu güç değeridir.

##### - İhtiyaç moment (T): [Nm]

Redüktörün kullanılacağı uygulamanın çalışabilmesi için ihtiyaç duyduğu moment değeridir. Seçilen redüktör için her zaman çıkış momentini eşit yada daha düşük olmalıdır.

##### - Müsade Edilen Eksenel ve Radyal Yükler

Fqem, Fqam: [N]

Redüktörün giriş veya çıkış milinde müsade edilen eksenel ve radyal yüklerdir.

##### - Servis Faktörü ( $f_s$ ):

Redüktörün çalıştığı şartlar ile uyumlu olması için gerekli olan emniyet katsayısıdır.  $f_s=1$ , düzgün ve sakin yüklerde, günlük sekiz saat, saatte 100 dur-kalk çalışmayı karşılar. Detaylar için redüktör seçim bölümüne bakınız.

#### Teknik Özellikler:

##### - Ses seviyesi:

Redüktörlerimizin ses seviyesi VDI 2159' da verilen redüktörler için müsade edilen ses seviyelerinin altındadır.

##### - Boya ve Korozyon Koruması:

Redüktörlerin standart rengi DIN1843'e göre RAL 7031 dir. İstek üzerine farklı renklerde boyanabilir. Nemli ve korozif bölgeler için istek üzerine farklı boya uygulanabilir.

#### Technical Explanations

##### - Output Torque ( $M_2$ ): [Nm]

Multiplication of motor output torque with transmission ratio and efficiency gives the result of output torque at the output shaft of the gear unit.

##### - Nominal Torque ( $M_a$ ): [Nm]

Nominal torque is the mechanical torque which the gearbox can resist under  $f_s=1$  conditions.

##### - Nominal Power ( $P_e$ ): [kW]

The nominal power is the power which gearbox can mechanically resist under  $f_s=1$  condition. The nominal powers are given on the performance tables.

##### - Ratio (i):

Ratio between output shaft speed and input shaft speed. Available ratios of Yılmaz Redüktör M series are between 3,5 to 23500.

##### - Equivalent Power and Torque

$P_{eq}$ : [kW],  $T_e$  [Nm]

For gearbox unit with constant speed but variable working conditions: This is the calculated power or torque which is equivalent to the values at working under constant working conditions.

##### - Required Power ( $P_M$ ): [kW]

Required power for the applications which is able to drive the system.

##### - Required Torque (T): [Nm]

Required torque for applications. Required torque always must be equal or smaller than output torque for selected gearbox.

##### - Permissible Axial and Overhung Loads:

Fqem, Fqam [N]

Permissible axial and overhung load at the output or input shaft of gearboxes.

##### - Service Factor ( $f_s$ ):

Service factor is a safety coefficient, which takes into account the different running conditions of the driven machine.  $f_s=1$  is used for uniform loads 8 hours working per day and up to 100 cycle per hour.

#### Technical Specifications:

##### - Noise Level:

The noise level of our gearboxes is below the permitted values defined in VDI guidelines 2159 for gear units.

##### - Coating and Corrosion Protection:

The gearboxes are painted with RAL 7031 according DIN1843. Different colors are available upon request. Paintings for high humidity or chemically aggressive environments are available upon request.

#### Technische Erläuterungen

##### - Ausgangsmoment ( $M_2$ ): [Nm]

Multiplikation von Ausgangsmoment des Motors mit Übersetzung und Division das Ergebnis mit Wirkungsgrad ergibt den Betrag von Ausgangsmoment der Getriebe.

##### - Nennmoment ( $M_a$ ): [Nm]

Mechanisches Belastungsmoment der Getriebe unter dem Bedingung  $f_s=1$ .

##### - Nennleistung ( $P_e$ ): [kW]

Die Nennleistung ist die mechanische Grenzfestigkeitsleistung für  $f_s=1$ . Kann von der Leistung-Drehzahltable abgelesen werden.

##### - Übersetzung (i):

Wird aus dem Verhältnis von Ausgang- zu Eingangswinkelgeschwindigkeit bestimmt. Gängige Übersetzungen von Yılmaz M Serie Getriebe liegt zwischen 3,5 bis 23500.

##### - Äquivalente Leistung und Moment

$P_{eq}$ : [kW],  $T_e$  [Nm]

Für mit konstanten Drehzahl aber unter veränderlichen Betriebsbedingungen arbeitende Getriebe berechnete Leistung und Moment äquivalent zu Werten beim Arbeiten unter konstanten Betriebsbedingungen.

##### - Notwendige Leistung ( $P_M$ ): [kW]

Für das Getriebe notwendige Leistung, um Arbeiten von Getriebe bei der für das Getriebe gedachten Anwendung zu gewährleisten.

##### - Notwendige Moment (T): [Nm]

Notwendige Moment für Anwendungen. Für den ausgewählte Getriebe soll das notwendige Moment gleich dem Ausgangsmoment oder kleiner als diesem Moment sein.

##### - Zulässige Axial- oder Querkräfte:

Fqem, Fqam [N]

Bei der Anwendungen während der Betrieb zulässige axiale oder radiale Eingangs- oder Ausgangsbelastungen.

##### - Betriebsfaktor ( $f_s$ ):

Dieser Faktor  $f_s$  ist ein Sicherheitsfaktor, damit die Getriebe unter verschiedenen Bedingungen mit genügender Sicherheit arbeitet.  $f_s=1$  gilt für gleichförmig Belastung, mit 8 Betriebsstunden pro Tag und bis zum 100 Schaltungen pro Stunde.

#### Technische Informationen:

##### - Geräuschpegel:

Geräuschstärken aller Getriebe bleiben unter die zulässigen Werte, die für die Getriebe in der VDI-Richtlinie 2159 festgelegt sind.

##### - Lackierung und Korrosionsschutz:

Die Getriebe werden mit der Farbe RAL 7031 nach DIN1843 lackiert. Auf Wunsch sind Sonderlackierungen möglich. Alle Getriebe können auf Wunsch auch in korrosionsgeschützter Ausführung für aggressive Umgebungen geliefert werden.

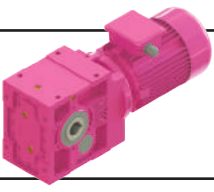

## Genel Bilgiler General Information Einführung



### - Yağlama:

K Serisi redüktörler yağlama tablolarında verilen yağlar ile doldurulmaktadır. Yağ detayları için yağlama bölümüne bakınız.

### - Aksesuarlar:

K Serisi redüktörlerde aşağıdaki aksesuarlar kullanılabilir

- IEC B5 Motor bağlantı flanşları
- Çıkış Bağlantı Flanşları
- Sıkma bileziği
- Geri dönüş kilidi
- Özel keçe çözümleri,
- Şeffaf yağ seviye göstergesi
- Tork kolu
- Elektromanyetik frenler

Diğer özel aksesuarlar için lütfen, YILMAZ REDÜKTÖR ile temasa geçiniz.

### - Lubrication:

*K series of gearboxes filled with oils which are indicated on lubrication tables. For lubrication details please refer to the lubrication section.*

### - Accessories:

*The following accessories can be applied to K series gearboxes.*

- IEC B5 Motor connection flange
- Output flanges
- Shrink Discs
- Backstops
- Special sealing solutions.
- Transparent oil level indicator,
- Torque arm
- Electromagnetic brakes.

*For other accessories please contact, YILMAZ REDÜKTÖR.*

### - Schmierung:

K Serie Getriebe werden mit Ölen entsprechend der Schmierungstabellen, falls nicht anders vereinbart, geliefert. Für weitere Schmierungsangaben siehe Kapitel Schmierung.

### - Zubehör:

Folgendes Zubehör kann für Getriebe der K Serie geliefert werden.

- IEC B5 Motor Adapter,
- Abtriebsflansch,
- Schrumpfscheiben,
- Rücklaufsperrn,
- Unterschiedliche Dichtungssysteme,
- Ölstandzeiger
- Drehmomentstütze
- Elektromagnetische Bremsen

Für weiteres Zubehör kontaktieren Sie bitte mit, YILMAZ REDÜKTÖR.

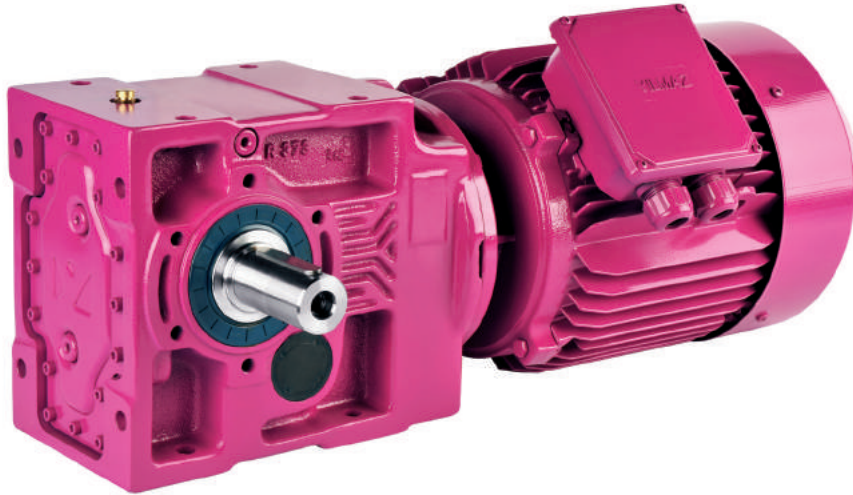

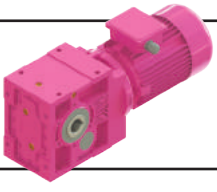

Genel Bilgiler  
General Information  
Einführung



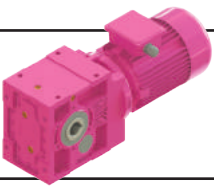

# Genel Bilgiler General Information Einführung



Tip Tanımlaması / Unit Designation / Typenbezeichnung

**K R 3 7 3 . 02 R - M2 T1 - 90S/4 - L05**

### Fren / Brake / Bremse

L-220V Fanlı / With Fan / Mit Lüfter	00- 5 Nm	10- 100 Nm
P-24V Fanlı / With Fan / Mit Lüfter	01- 10 Nm	20- 200 Nm
S-220 V Fansız / Without Fan / Ohne Lüfter	02- 25 Nm	30- 300 Nm
Z-24 V Fansız / Without Fan / Ohne Lüfter	04- 40 Nm	40- 400 Nm
	05- 50 Nm	50- 500 Nm

### Motor Büyüklüğü / Motor Size / Motorbaugröße

#### KV Tipleri için / For KV types / Für typen KV

90 S / 4

Kutup Sayısı / Pole Number /  
Anzahl der polen  
Gövde uzunluğu / Frame Length /  
Gehäuselänge  
Motor büyüklüğü / Motor size /  
Motorbaugröße

#### KN tipleri için / For KN Types / Für Typen KN

A06 : 63 B5	A10 : 100 B5	A20 : 200 B5
B06 : 63 B14	B10 : 100 B14	A22 : 225 B5
A07 : 71 B5	A11 : 112 B5	A25 : 250 B5
A08 : 80 B5	A13 : 132 B5	A31 : 315 B5
B08 : 80 B14	B13 : 132 B14	
A09 : 90 B5	A16 : 160 B5	
B09 : 90 B14	A18 : 180 B5	

### Tork Kolu Pozisyonu / Torque Arm Position / Position von Drehmomentstütze

Sayfa 471 ve 472'ye bakınız. / Please see page 471 and 472 / Siehe seite 471 und 472

### Montaj Pozisyonu / Mounting Position / Bauform

Sayfa 34'e bakınız. / Please see page 34 / Siehe seite 34

### Çıkış Mil - Flanş Yönü / Output Shaft - Flange Position / Ausgangswelle - Seite von der Flansch

### Çıkış Özelliği / Output Specification / Eigenschaft der Ausgang

- 00 :Standart delik milli / Hollow output shaft / Standarte Ausführung mit Hohlwelle
- 01 :Mil Çıkışlı / Solid output shaft / Vollwelle
- 02 :Flanşlı ve mil çıkışlı / Solid output shaft and with Flange / Mit Flansch und Abtriebsvollwelle
- 03 :Flanşlı ve delik milli çıkışlı / Flanged and hollow output shaft / Mit Flansch und Hohlausgangswelle
- 04 :Çift çıkış milli / With double output shaft / Mit doppelte Abtriebswelle
- 05 :Çift flanşlı ve çift çıkış milli / Double flanged and double output shaft / Mit doppelte Flansch und doppelte Abtriebswelle
- 08 :Çift flanşlı delik milli /Double flanged and hollow output shaft / Doppelte Flansch und Aufsteckenwelle
- 0S :Sıkma Bilezikli / Shrink disk output / Schrumpfscheibe
- 0E :Ekstruder Çıkışlı / Extruder output / Extruder-Ausgang

### Kademe Sayısı / Stage / Anzahl der Stufen

- 2 kademe / 2 Stages / 2 Stufig
- 3 kademe / 3 Stages / 3 Stufig
- 4 kademe / 4 Stages / 4 Stufig
- 5 kademe / 5 Stages / 5 Stufig
- 6 kademe / 6 Stages / 6 Stufig

### Revizyon Numarası / Revision Number / Änderungsnummer

### Gövde Büyüklük / Housing Size / Größe von Gehäuse

0...8

### Giriş Tipi / Input Type / Eingangstyp

R :Motorlu / With Motor / Mit Motor

N :Motorsuz ve IEC B5/B14 Flanş girişli / IEC B5 / B14 Flanged without Motor / Ohne Motor und mit IEC B5/B14 Eingangsflansch

V :Motorlu ve IEC B5/B14 Flanş girişli / IEC B5 / B14 Flanged with Motor / Mit Motor und IEC B5/B14 Eingangsflansch

T :Motorsuz / Without Motor / Eingang mit Vollwelle ohne Motor

### Redüktör Tipi / Gearbox Type / Getriebe

K Serisi / K Serie / K Serie

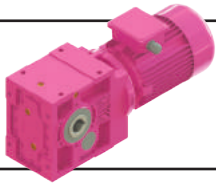

# Genel Bilgiler

## General Information

### Einführung



#### Tip Tanımlaması / Unit Designation / Typenbezeichnung

KR..00..	<b>Konik-Helisel tip redüktörler, motor bağlantılı, delik milli çıkış / Bevel-Helical type geared motors , Direct coupled motor, Hollow shaft output /</b> Flachgetriebemotoren, Verbunden mit Motor, Ausgang mit Hohlwelle.
KR..01..	<b>Konik-Helisel tip redüktörler, motor bağlantılı, milli çıkış / Bevel-Helical type geared motors, Direct motor coupled, solid output shaft /</b> Flachgetriebemotoren, Verbunden mit Motor, Ausgang mit Vollwelle.
KR..02..	<b>Konik-Helisel tip redüktörler, motor bağlantılı, mil ve flanş çıkışlı / Bevel-Helical type geared motors, Direct motor coupled, Solid output shaft and output flange /</b> Flachgetriebemotoren, Verbunden mit Motor, Ausgang mit Vollwelle und Flansch.
KR..03..	<b>Konik-Helisel tip redüktörler, motor bağlantılı delik milli ve flanş çıkışlı / Bevel-Helical type geared motors, Direct motor coupled, Hollow output shaft and output flange /</b> Flachgetriebemotoren, Verbunden mit Motor, Ausgang mit Hohlwelle und Flansch.
KR..04..	<b>Konik-Helisel tip redüktörler, motor bağlantılı, çift çıkış milli / Bevel-Helical type gearboxes, Direct motor coupled, double output shaft, /</b> Flachgetriebemotoren, Verbunden mit Motor, mit doppelter Ausgangswelle
KR..05..	<b>Konik-Helisel tip redüktörler, motor bağlantılı çift milli ve çift flanş çıkışlı / Bevel-Helical type geared motors, Direct motor coupled, double hollow output shaft and double flange output. /</b> Flachgetriebemotoren, Verbunden mit Motor, Ausgang mit Hohlwelle und Flansch.
KR..08..	<b>Konik-Helisel tip redüktörler, motor bağlantılı delik milli ve çift flanş çıkışlı / Bevel-Helical type geared motors, Direct motor coupled, double hollow output shaft and double flange output. /</b> Flachgetriebemotoren, Verbunden mit Motor, Ausgang mit Hohlwelle und Flansch.
KR..0S..	<b>Konik-Helisel tip redüktörler, motor bağlantılı, sıkma bilezik çıkışlı / Bevel-Helical type geared motors Direct motor coupled , Shrink disk output /</b> Flachgetriebemotoren, Verbunden mit Motor, Ausgang mit Schrumpfscheibe
KR..0E..	<b>Konik-Helisel tip motorlu redüktörler, motor bağlantılı, ekstruder çıkışlı / Bevel-Helical type geared motors Direct motor coupled , extruder output /</b> Flachgetriebemotoren, Verbunden mit Motor, Ausgang mit Extruder
KN..00..	<b>Konik-Helisel tip redüktörler, IEC B5/B14 flanşlı motorsuz , delik milli çıkış / Bevel-Helical type gearboxes, IEC B5/B14 flanged input without motor, hollow output shaft /</b> Flachgetriebe, ohne Motor mit IEC B5/B14 Flansch , Ausgang mit Hohlwelle.
KN..01..	<b>Konik-Helisel tip redüktörler, IEC B5/B14 flanşlı motorsuz , mil çıkışlı / Bevel-Helical type gearboxes, IEC B5/B14 flanged input without motor, Solid output shaft /</b> Flachgetriebe, ohne Motor mit IEC B5/B14 Flansch, Ausgang mit Vollwelle.
KN..02..	<b>Konik-Helisel tip redüktörler, IEC B5/B14 flanşlı motorsuz, mil ve flanş çıkışlı / Bevel-Helical type gearboxes, IEC B5/B14 flanged input without motor, Solid output shaft and output flange /</b> Flachgetriebe, ohne Motor mit IEC B5/B14 Flansch, Ausgang mit Vollwelle und Flansch.
KN..03..	<b>Konik-Helisel tip redüktörler, IEC B5/B14 flanşlı motorsuz, delik milli ve flanş çıkışlı / Bevel-Helical type gearboxes, IEC B5/B14 flanged input without motor, Hollow output shaft and output flange /</b> Flachgetriebe, ohne Motor mit IEC B5/B14, Ausgang mit Hohlwelle und Flansch.
KN..04..	<b>Konik-Helisel tip redüktörler, IEC B5/B14 flanşlı motorsuz, çift çıkış milli / Bevel-Helical type gearboxes, IEC B5/B14 flanged without motor, double output shaft, /</b> Flachgetriebe, ohne Motor mit IEC B5/B14, mit doppelter Ausgangswelle
KN..05..	<b>Konik-Helisel tip redüktörler, IEC B5/B14 flanşlı motorsuz ,çift milli ve çift flanş çıkışlı / Bevel-Helical type geared motors, IEC B5/B14 flanged input without motor, double hollow output shaft and flange output. /</b> Flachgetriebemotoren, Verbunden mit Motor, Ausgang mit Hohlwelle und Flansch.
KN..08..	<b>Konik-Helisel tip redüktörler, IEC B5/B14 flanşlı motorsuz ,delik milli ve çift flanş çıkışlı / Bevel-Helical type geared motors, IEC B5/B14 flanged input without motor ,double hollow output shaft and double flange output. /</b> Flachgetriebemotoren, Verbunden mit Motor, Ausgang mit Hohlwelle und Flansch.
KN..0S..	<b>Konik-helisel tip helisel redüktörler, IEC B5/B14 flanşlı motorsuz, sıkma bilezik çıkışlı / Bevel-Helical type geared motors IEC B5/B14 flanged without motor, Shrink disk Output /</b> Flachgetriebemotoren, ohne Motor mit IEC B5/B14, Ausgang mit Schrumpfscheibe
KN..0E..	<b>Konik-helisel tip helisel redüktörler, IEC B5/B14 flanşlı motorsuz, ekstruder çıkışlı / Bevel-Helical type geared motors IEC B5/B14 flanged without motor, extruder output /</b> Flachgetriebemotoren, ohne Motor mit IEC B5/B14, Ausgang mit Extruder.
KV..00..	<b>Konik-Helisel tip helisel redüktörler, IEC B5/B14 flanşlı, motorlu, delik milli çıkış / Bevel-helical type gearboxes, IEC B5/B14 flanged input with coupled motor, hollow output shaft /</b> Flachgetriebe, Verbunden mit IEC B5/B14 Motorverbindung, Ausgang mit Hohlwelle.
KV..01..	<b>Konik-Helisel tip helisel redüktörler, IEC B5/B14 flanşlı, motorlu, mil çıkışlı / Bevel-helical type gearboxes, IEC B5/B14 flanged input with coupled motor, solid output shaft /</b> Flachgetriebe, Verbunden mit IEC B5/B14 Motorverbindung, Ausgang mit Vollwelle.
KV..02..	<b>Konik-Helisel tip helisel redüktörler, IEC B5/B14 flanşlı, motorlu, mil ve flanş çıkışlı / Bevel-helical type gearboxes, IEC B5/B14 flanged input with coupled motor, with solid output shaft and output flange /</b> Flachgetriebe, Verbunden mit IEC B5/B14 Motorverbindung, Ausgang mit Vollwelle und Flansch.
KV..03..	<b>Konik-Helisel tip helisel redüktörler, IEC B5/B14 flanşlı, motorlu, delik milli ve flanş çıkışlı / Bevel-helical type gearboxes, IEC B5/B14 flanged input with coupled motor, Hollow output shaft and output flange /</b> Flachgetriebe, Verbunden mit IEC B5/B14 Motorverbindung, Ausgang mit Hohlwelle und Flansch.
KV..04..	<b>Konik-Helisel tip helisel redüktörler, motor bağlantılı, çift çıkış milli / Bevel-Helical type gearboxes, IEC B5/B14 flanged input with coupled motor, double output shaft, /</b> Flachgetriebe, Verbunden mit IEC B5/B14 Motorverbindung, mit doppelter Ausgangswelle
KV..05..	<b>Konik-Helisel tip helisel redüktörler, IEC B5/B14 flanşlı, motorlu, çift milli ve çift flanş çıkışlı / Bevel-helical type gearboxes, IEC B5/B14 flanged input with coupled motor, double output shaft and double output flange /</b> Flachgetriebe, Verbunden mit IEC B5/B14 Motorverbindung, Ausgang mit Hohlwelle und Flansch.
KV..08..	<b>Konik-Helisel tip redüktörler, IEC B5/B14 flanşlı, motorlu, delik milli ve çift flanş çıkışlı / Bevel-Helical type geared motors, IEC B5/B14 flanged input with direct coupled motor, double hollow output shaft and double flange output. /</b> Flachgetriebemotoren, Verbunden mit Motor, Ausgang mit Hohlwelle und Flansch.
KV..0S..	<b>Konik-Helisel tip redüktörler, IEC B5/B14 flanşlı motorlu, sıkma bilezik çıkışlı / Bevel-Helical geared motors IEC B5/B14 flanged with direct coupled motor, Shrink disk output /</b> Flachgetriebemotoren, Verbunden mit IEC B5/B14 Motorverbindung, Ausgang mit Schrumpfscheibe
KV..0E..	<b>Konik-Helisel tip helisel redüktörler, IEC B5/B14 flanşlı motorlu, ekstruder çıkışlı / Bevel-Helical geared motors IEC B5/B14 flanged with direct coupled motor, Extruder Output /</b> Flachgetriebemotoren, Verbunden mit IEC B5/B14 Motorverbindung, Ausgang mit extruder.
KT..00..	<b>Konik-Helisel tip helisel redüktörler, motorsuz ve mil girişli, delik milli çıkış / Bevel-Helical geared unit, Solid shaft input without motor, Hollow output shaft /</b> Flachgetriebe, Eingang mit Vollwelle ohne Motor, Ausgang mit Hohlwelle.
KT..01..	<b>Konik-Helisel tip helisel redüktörler, motorsuz ve mil girişli, mil çıkışlı / Bevel-Helical geared units, Solid shaft input without motor, Solid output shaft /</b> Flachgetriebe, Eingang mit Vollwelle ohne Motor, Ausgang mit Vollwelle.
KT..02..	<b>Konik-Helisel tip helisel redüktörler, motorsuz ve mil girişli, mil ve flanş çıkışlı / Bevel-Helical gear units, Solid shaft input without motor, Solid output shaft and flange output /</b> Flachgetriebe, Eingang mit Vollwelle ohne Motor, Ausgang mit Vollwelle und Flansch.
KT..03..	<b>Konik-Helisel tip helisel redüktörler, motorsuz ve mil girişli, delik milli ve flanş çıkışlı / Bevel-Helical gear units, solid shaft input without motor, Hollow output shaft and output flange /</b> Flachgetriebe, Eingang mit Vollwelle ohne Motor, Ausgang mit Hohlwelle und Flansch.
KT..04..	<b>Konik-Helisel tip redüktörler, motor bağlantılı, çift çıkış milli / Bevel-Helical type gearboxes, solid input shaft, double output shaft, /</b> Flachgetriebe, Eingang mit Vollwelle, mit doppelter Ausgangswelle
KT..05..	<b>Konik-Helisel tip helisel redüktörler, IEC B5/B14 flanşlı, motorsuz, çift milli ve çift flanş çıkışlı / Bevel-helical type gearboxes, IEC B5/B14 flanged input without motor, double output shaft and double output flange /</b> Flachgetriebe, Verbunden mit IEC B5/B14 Motorverbindung, Ausgang mit Hohlwelle und Flansch.
KT..08..	<b>Konik-Helisel tip redüktörler, IEC B5/B14 flanşlı, motorlu, delik milli ve çift flanş çıkışlı / Bevel-Helical type geared motors, IEC B5/B14 flanged input with without motor, double hollow output shaft and double flange output. /</b> Flachgetriebemotoren, Verbunden mit Motor, Ausgang mit Hohlwelle und Flansch.
KT..0S..	<b>Konik-Helisel tip helisel redüktörler, motorsuz, sıkma bilezik çıkışlı / Bevel-Helical gear motors, Solid shaft input without motor, Shrink Disk Output /</b> Flachgetriebe, ohne Motor, Ausgang mit Schrumpfscheibe
KT..0E..	<b>Konik-Helisel tip helisel redüktörler, motorsuz, ekstruder çıkışlı / Bevel-Helical gear motors, Solid shaft input without motor, Extruder Output /</b> Flachgetriebe, ohne Motor, Ausgang mit Extruder.

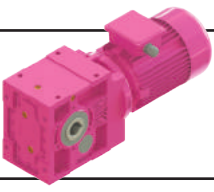

# Genel Bilgiler

## General Information

### Einführung

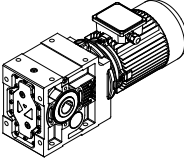
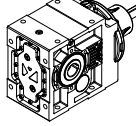
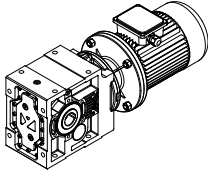
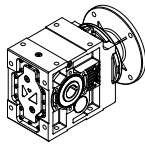
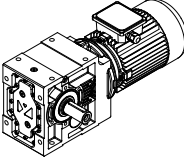
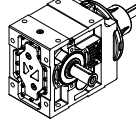
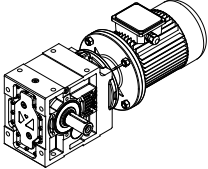
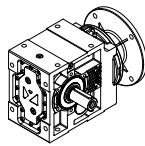
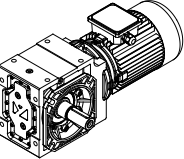
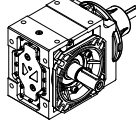
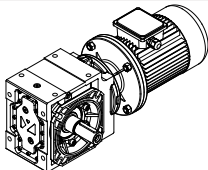
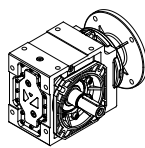
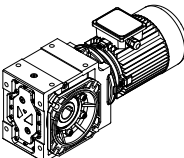
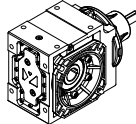
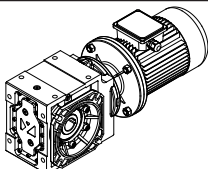
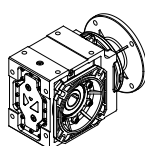
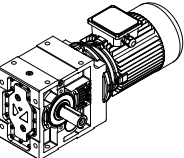
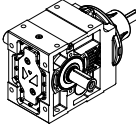
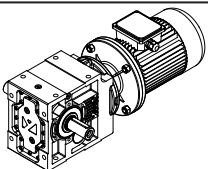
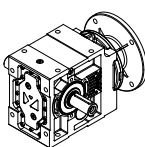
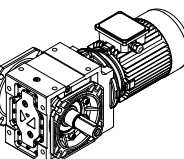
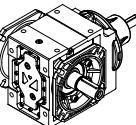
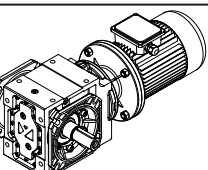
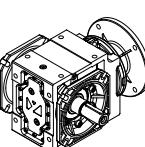
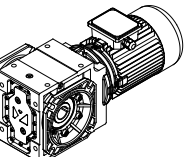
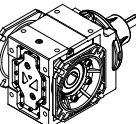
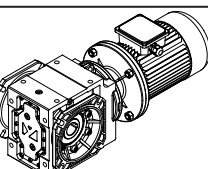
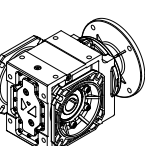
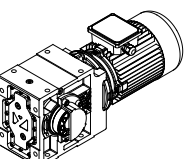
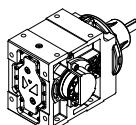
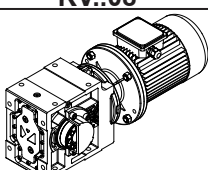
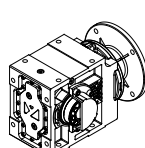
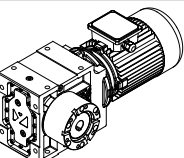
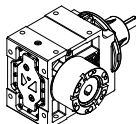
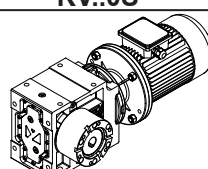
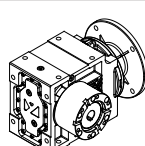

#### Tip Tanımlaması / Unit Designation / Typenbezeichnungen

 <b>KR..00</b>	 <b>KT..00</b>	 <b>KV..00</b>	 <b>KN..00</b>
 <b>KR..01</b>	 <b>KT..01</b>	 <b>KV..01</b>	 <b>KN..01</b>
 <b>KR..02</b>	 <b>KT..02</b>	 <b>KV..02</b>	 <b>KN..02</b>
 <b>KR..03</b>	 <b>KT..03</b>	 <b>KV..03</b>	 <b>KN..03</b>
 <b>KR..04</b>	 <b>KT..04</b>	 <b>KV..04</b>	 <b>KN..04</b>
 <b>KR..05</b>	 <b>KT..05</b>	 <b>KV..05</b>	 <b>KN..05</b>
 <b>KR..08</b>	 <b>KT..08</b>	 <b>KV..08</b>	 <b>KN..08</b>
 <b>KR..0S</b>	 <b>KT..0S</b>	 <b>KV..0S</b>	 <b>KN..0S</b>
 <b>KR..0E</b>	 <b>KT..0E</b>	 <b>KV..0E</b>	 <b>KN..0E</b>

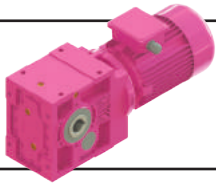

# Genel Bilgiler

## General Information

### Einführung



#### Örnek Tip Tanımlamaları

##### KR273.00-90S/4-L05

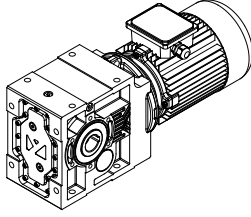

**K**.....: K serisi redüktör  
**R**.....: Motor bağlantılı  
**2**.....: Gövde büyüklük  
**7**.....: Revizyon numarası  
**3**.....: Kademe sayısı  
**00**.....: Delik mil çıkışı  
**90S/4**.....: Motor büyüklüğü  
**L05**.....: Fren Tipi

#### KT373.01

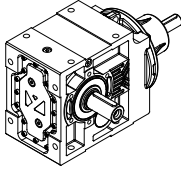

**K**.....: K serisi redüktör  
**T**.....: Motorsuz giriş millî  
**3**.....: Gövde büyüklüğü  
**7**.....: Revizyon numarası  
**3**.....: Kademe sayısı  
**01**.....: Mil çıkışı

#### KN473.03 - A11

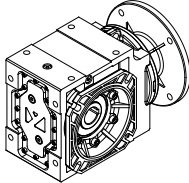

**K**.....: K serisi redüktör  
**N**.....: Motorsuz ve IEC B5 giriş flanşlı  
**4**.....: Gövde büyüklüğü  
**7**.....: Revizyon numarası  
**3**.....: Kademe sayısı  
**03**.....: Delik millî flanş bağlantılı çıkış  
**A11**.....: 112 tip motor, B5 bağlantı flanş

#### KV573.0S-100L/4

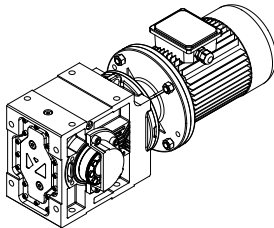

**K**.....: K serisi redüktör  
**V**.....: Motorlu ve B5/B14 giriş flanşlı  
**5**.....: Gövde büyüklüğü  
**7**.....: Revizyon numarası  
**3**.....: Kademe sayısı  
**0S**.....: Sıkma bilezikli delik millî çıkış  
**100L/4**.....: Motor büyüklüğü ve kutup sayısı

#### Sample Designations

##### KR273.00-90S/4-L05

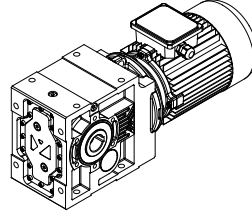

**K**.....: K serie of gearbox  
**R**.....: Direct motor coupled  
**2**.....: Gear unit size  
**7**.....: Revision number  
**3**.....: Stage number  
**00**.....: Hollow shaft output  
**90S/4**.....: Motor frame size  
**L05**.....: Brake type

#### KT373.01

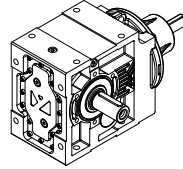

**K**.....: K series of gearbox  
**T**.....: Solid input shaft  
**3**.....: Gear unit size  
**7**.....: Revision number  
**3**.....: Stage number  
**01**.....: Solid output shaft

#### KN473.03 - A11

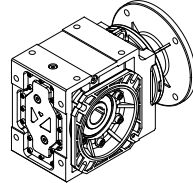

**K**.....: K series of gearbox  
**N**.....: IEC B5 flange without motor input  
**4**.....: Gear unit size  
**7**.....: Revision number  
**3**.....: Stage number  
**03**.....: Flanged hollow shaft output  
**A11**.....: Motor type 112, B5 flange

#### KV573.0S-100L/4

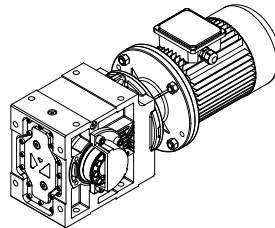

**K**.....: K series of gearbox  
**V**.....: Motor input with B5/B14 flanged  
**5**.....: Gear unit size  
**7**.....: Revision number  
**3**.....: Stage number  
**0S**.....: Hollow shaft output with shrink disk  
**100L/4**.....: Motor size and number of poles

#### Typenbezeichnungsbeispiele

##### KR273.00-90S/4-L05

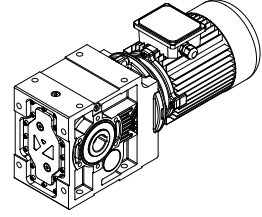

**K**.....: K Serie Getriebe  
**R**.....: Motorverbindung  
**2**.....: Größe von Gehäuse  
**7**.....: Änderungsnummer  
**3**.....: Stufenanzahl (2 stufig)  
**00**.....: Hohlausgangswelle  
**90S/4**.....: Motorbaugröße  
**L05**.....: Bremse

#### KT373.01

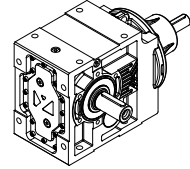

**K**.....: K Serie Getriebe  
**T**.....: Vollwelleneingang ohne Motor  
**3**.....: Größe der Gehäuse  
**7**.....: Änderungsnummer  
**3**.....: Stufenanzahl  
**01**.....: Vollwelle

#### KN473.03 - A11

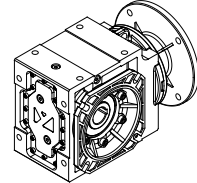

**K**.....: K Serie Getriebe  
**N**.....: IEC B5 Flansch ohne Motor  
**4**.....: Größe von Gehäuse  
**7**.....: Änderungsnummer  
**3**.....: Stufenanzahl  
**03**.....: Hohlwelle mit Flanschverbindung  
**A11**.....: Motortyp 112, B5 Motorflansch

#### KV573.0S-100L/4

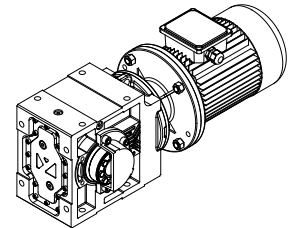

**K**.....: K Serie Getriebe  
**V**.....: Mit Motor und IEC B5/B14 Flansch  
**5**.....: Größe von Gehäuse  
**7**.....: Änderungsnummer  
**3**.....: Stufenanzahl  
**0S**.....: Hohlwelle mit Schrumpfscheibe  
**100L/4**.....: Motorbaugröße und Anzahl der Pole

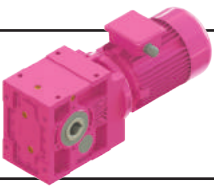

# Genel Bilgiler

## General Information

### Einführung



#### Motor Büyüklüğüne Göre Geometrik Mümkün Çevrim Oranları

Geometrically Possible Combinations of Ratios According to Motor Size

Geometrisch mögliche Kombinationen von Übersetzungen nach Motorbaugröße

##### Motor Büyüklüğü / Motor Size / Motorbaugröße

Tip Type	Kademe Stages	63	71	80	90	100	112	132
KR002..	2	7,46-19,88	7,46-19,88	7,46-19,88	7,46-13,26	-	-	-
KR003..	3	23,79-120,91	23,79-120,91	23,79-29,95 45,41-57,16	23,79-29,95 45,41-57,15	-	-	-
KR102..	2	6,28-25,50	6,28-25,50	6,28-25,50	6,28-17,30	-	-	-
KR103..	3	20,03-129,27	20,03-129,27	20,03-76,13 118,19-129,27	20,03-76,13	-	-	-
KR202..	2	5,35-23,79	5,35-23,79	5,35-23,79	5,35-23,79	5,35-15,26	5,35-10,57	-
KR203..	3	22,06-138,53	22,06-138,53	22,06-119,62	22,06-119,62	22,06-104,49	22,06-72,37	-
KR273..	3	6,94-113,65	6,94-113,65	6,94-83,48	6,94-83,48	6,94-72,92	6,94-50,51	-
KR275..	5	54,40-719,79	54,40-719,79	54,40-719,79	54,40-719,79	-	-	-
KR276..	6	735,5-1759,48	735,5-1759,48	735,42-1759,48	735,42-1759,48	-	-	-
KR373..	3	-	7,73-9,97 14,44-21,90 33,65-148,75	7,73-9,97 14,44-21,90 33,65-110,61	7,73-9,97 14,44-21,90 33,65-110,61	5,68-97,26	5,68-68,65	5,68-51,05
KR374..	4	127,14-367,43	127,14-367,43	127,14-367,43	127,14-367,43	-	-	-
KR375..	5	312,5-1094,97	312,5-1094,97	312,5-1094,97	312,5-1094,97	-	-	-
KR376..	6	853,34-3467,39	853,34-3467,39	853,34-3467,39	853,34-3467,39	-	-	-
KR473..	3	-	-	23,76-30,11 60,63-153,47	23,76-30,11 60,63-153,47	7,48-110,95	6,21-97,79	6,21-76,83
KR474..	4	-	160,79-472,63	160,79-472,63	160,79-472,63	160,75-207,41	160,79-181,88	-
KR475..	5	509,34-1767,9	509,34-1767,9	509,34-1767,9	509,34-1767,9	509,34-1142,99	509,34-971,77	-
KR476..	6	2183,54-5226,85	2183,54-5226,85	2183,54-5226,85	2183,54-5226,85	2183,54-3602,83	2183,54-3379,28	-
KR573..	3	-	-	-	-	20,24-25,78 44,73-125,51	20,24-25,78 38,16-109,86	6,91-97,19
KR574..	4	-	117,96-469,74	117,96-469,74	117,96-469,74	117,96-328,56	117,96-158,64 246,42	117,96
KR575..	5	507,09-2236,28	507,09-2236,28	507,09-2236,28	507,09-2236,28	-	-	-
KR576..	6	2328,84-6611,61	2328,84-6611,61	2328,84-6611,61	2328,84-6611,61	-	-	-
KR673..	3	-	-	-	-	80,38-128,24	80,38-128,24	8,31-14,49 18,74-128,24
KR674..	4	-	-	82,25-363,81	82,25-363,81	82,25-363,81	82,25-321,51	82,25-123,38
KR675..	5	-	531,08-1875,03	531,08-1875,03	531,08-1875,03	423,9-1875,03	423,9-809,27	423,9-724,08
KR676..	6	-	1884,33-12680,66	1884,33-12680,66	1884,33-12680,66	1884,33-5445,72	1884,33-3844,04	1884,33-2858,39
KR773..	3	-	-	-	-	-	-	11,44-12,89 23,52-26,52 45,36-111,63
KR774..	4	-	-	127,11-396,00	127,11-396,00	127,11-139,00	127,11-139,00	127,11-311,14
KR775..	5	-	547,17-3203,12	547,17-3203,12	547,17-3203,12	436,74-2066,04	436,74-833,78	436,74-655,11
KR776..	6	-	1941,39-15618,73	1941,39-15618,73	1941,39-15618,73	1941,39-5610,63	1941,39-3960,44	1941,39-2944,95
KR873..	3	-	-	-	-	-	-	49,75-115,87
KR874..	4	-	-	-	-	86,63-438,70	86,63-383,99	86,63-339,7
KR875..	5	-	463,83-1891,08	463,83-1891,08	463,83-1891,08	463,83-1891,08	463,83-1671,18	463,83-1313,07
KR876..	6	-	2074,42-12789,19	2074,42-12789,19	2074,42-12789,19	2074,42-11245,67	2074,42-7938,12	2074,42-5902,70

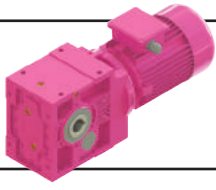

# Genel Bilgiler

## General Information

### Einführung



#### Motor Büyüklüğüne Göre Geometrik Mümkün Çevrim Oranları

Geometrically Possible Combinations of Ratios According to Motor Size  
Geometrisch mögliche Kombinationen von Übersetzungen nach Motorbaugröße

#### Motor Büyüklüğü / Motor Size / Motorbaugröße

Tip Type Typ	Kademe Stages Stufen	160	180	200	225	250	280
KR002..	2	-	-	-	-	-	-
KR003..	3	-	-	-	-	-	-
KR102..	2	-	-	-	-	-	-
KR103..	3	-	-	-	-	-	-
KR202..	2	-	-	-	-	-	-
KR203..	3	-	-	-	-	-	-
KR273..	3	-	-	-	-	-	-
KR275..	5	-	-	-	-	-	-
KR276..	6	-	-	-	-	-	-
KR373..	3	-	-	-	-	-	-
KR374..	4	-	-	-	-	-	-
KR375..	5	-	-	-	-	-	-
KR376..	6	-	-	-	-	-	-
KR473..	3	6,21-23,19 ; 25,15 39,11-59,19 ; 64,17	6,21-20,07 39,11-51,22	-	-	-	-
KR474..	4	-	-	-	-	-	-
KR475..	5	-	-	-	-	-	-
KR476..	6	-	-	-	-	-	-
KR573..	3	6,91-82,14	6,91-67,37	6,91-18,80 30,25-35,34	-	-	-
KR574..	4	-	-	-	-	-	-
KR575..	5	-	-	-	-	-	-
KR576..	6	-	-	-	-	-	-
KR673..	3	8,31-100,90	8,31-90,21	8,31-68,47	8,31-9,45 16,54-21,32 39,26-44,65	-	-
KR674..	4	-	-	-	-	-	-
KR675..	5	423,9-489,82	423,9	-	-	-	-
KR676..	6	-	-	-	-	-	-
KR773..	3	7,41-111,63	7,41-99,00	7,41-76,59	7,41-51,13	7,41-51,13	-
KR774..	4	-	-	-	-	-	-
KR775..	5	-	-	-	-	-	-
KR776..	6	-	-	-	-	-	-
KR873..	3	11,05-13,93 19,26-24,28 34,28-115,87	11,05-13,93 19,26-24,28 34,28-103,24	9,63-81,06	9,63-55,53	9,63-55,53	9,63-43,22
KR874..	4	86,63-235,47	86,63-235,47	-	-	-	-
KR875..	5	-	-	-	-	-	-
KR876..	6	-	-	-	-	-	-

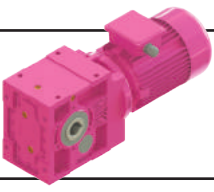

# Genel Bilgiler

## General Information

### Einführung



### Servis Faktörü

Servis faktörü (fs) redüktörün çalıştığı şartlar ile uyumlu olması için gerekli olan emniyet katsayısıdır. "fs =1" Düzgün ve sakin yüklerde, günlük sekiz saat ve saatte yüz start çalışmayı karşılar.

Aşağıdaki etkenlere bağlıdır:

- Günlük çalışma süresi
- Yük sınıfı
- Bir saatteki start sayısı
- Redüktör tahrik tipi
- Diğer gözlemler

Bu etkenleri göz önüne aldığımızda, gerekli servis faktörünü belirlemek için:

1. Makinanın günlük çalışma süresini tespit ediniz.
2. Makinanın ne türde yükler verdiğini tespit ediniz (Sayfa 17-18).

- U - Düzgün ve sabit yükler
- M - Orta darbeli yükler
- H - Ağır darbeli yükler

Yük sınıfının daha teknik seçimi için rotora indirgenmiş toplam atalet momenti formülünden faydalanabilirsiniz (Sayfa 18).

3. Saatteki start sayısını tespit ediniz.
4. İlk üç maddeye bağlı servis faktörünü aşağıdaki tablodan seçiniz.

5. fs Redüktörümüzün tahrik tipine bağlı olarak "k" katsayısı ile çarpılarak artırılır.

- k=1 :Elektrik motoru veya hidromotor  
k=1.25 :İçten yanmalı çok silindirli motor  
k=1.5 :İçten yanmalı tek silindirli motor

### Service Factor

Service Factor (fs) is a safety coefficient, which takes into account the different running conditions of the driven machine. "fs=1" is used for uniform loads 8 hours working per day and up to 100 starts per hour.

Service factor depends on:

- Running time
- Nature of load
- Frequency of starting
- Driver type
- Other considerations

For the right selection of the needed service factor for your machine;

1. Determine the running time of driven machine.
2. Select the nature of load of driven machine (Page 17-18).

- U - Uniform loads
- M - Moderate loads
- H - Heavy shock loads

For a better selection, the nature of load can be calculated from the formulas given (page 18).

3. Determine frequency of starting.
4. After determining the above mentioned factors, the service factor can be easily selected from the table given below.
5. The selected service factor multiplied with the factor "k" according to the driver type;

- k=1 :Electric motor or Hydrolicmotor  
k=1.25 :Multicylinder internal combustion engine  
k=1.5 :Single cylinder internal combustion engine

### Betriebsfaktor

Der Betriebsfaktor (fs) ist ein Sicherheitsfaktor für die Getriebe, damit sie unter den Betriebsbedingungen sicher arbeiten. "fs =1" steht für gleichförmige Belastung, 8 Stunden pro Tag und bis zu 100 Schaltungen pro Stunde.

Betriebsfaktor ist abhängig von:

- Betriebsdauer
- Belastungsart
- Schalthäufigkeit
- Antriebsart
- Andere Faktoren

Um die richtigen Betriebsfaktor festzulegen;

1. Betriebsdauer der angetriebenen Maschine bestimmen.
2. Belastungsart der angetriebenen Maschine auswählen.

- U - Gleichförmige Belastung
- M - Ungleichförmige Belastung
- H - Stark Ungleichförmige Belastung

Um eine bessere Auswahl zu treffen, können die Belastungsarten mit den angegebenen Formeln (Seite 18) errechnet werden.

3. Schalthäufigkeit bestimmen.
4. Nach Bestimmen der oben angegebenen Werte, können die Betriebsfaktoren von der unten stehenden Tabelle entnommen werden.
5. Der ausgewählte Betriebsfaktor muß mit dem Faktor "k" abhängig von der Antriebsart multipliziert werden

- k=1 :Elektromotor oder Hydraulikmotor  
k=1.25 :Vielzylindermotor  
k=1.5 :Einzyldermotor

Günlük Çalışma Süresi  
Operating Time hour / Day  
Laufzeit Std. / Tag

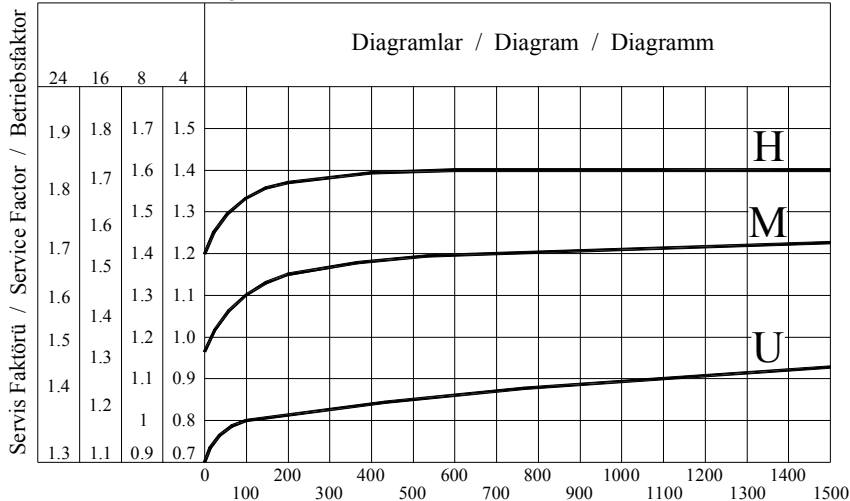

Start sayısı / Saat  
Cycle / Hour  
Schaltungen / Std.

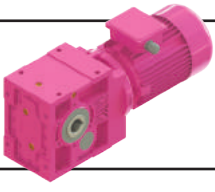

# Genel Bilgiler

## General Information

### Einführung



#### Yük Sınıflandırması

##### Krenler:

- U - Kaldırma Dişlileri
- Palanga Dişlileri
- M - Bomlu Vinç Dişlileri
- Yana Döndürme Dişlileri
- H - Yürütme Dişlileri

##### Pompalar:

- U - Santrifuj Pompalar (ince sıvı)
- M - Santrifuj Pompalar (yarı sıvı)
- H - Basınçlı Pompalar
- Dalgiç Pompalar

##### Taş ve Kil İşleme Makinaları:

- H - Çekiçli Değirmenler
- Döner Fırınlr
- Dövücü Değirmenler
- Kırıcılar
- Küreli Değirmenler
- Tuğla Presi
- Tüp Değirmenler

##### Tekstil Makinaları:

- M - Basma ve Boyama Makinaları
- Dokuma Tezgahları
- Hallac Makinaları
- Harman Makinaları
- Taneleme (Debegat )Tekneleri

##### Yağ Sanayi:

- M - Besleme Pompaları
- Döner Delme Teçhizatları

##### Yiyecek Sanayi:

- M - Kutu Bıçaklar
- Kutu Kaplama
- Mayalama Tekneleri
- H - Kenar Açma

##### Çamaşır Yıkama Makinaları:

- M - Döner Kurutucular
- Yıkama Makinaları

##### Hadde Makinaları:

- M - Hız Ayarlı Silindirler
- Sabit Silindirler
- Sarma Makaraları
- Tel Çekme
- H - Çubuk Kesme Makinaları
- Döner Tablalar (büyük)
- Kabuk Sıyırma Makinaları
- Plaka Haddeleme
- Silindir Haddeleme
- Soğuk Haddeleme

#### Load Classification

##### Cranes:

- U - Hoist Gears
- Lifting Gears
- M - Defrocking jib Gears
- Slowing Gears
- H - Travelling Gears

##### Pumps:

- U - Centrifugal Pumps (light liquids)
- M - Centrifugal Pumps (semi liquid)
- H - Pressure Pumps
- Plunger Pumps

##### Stone and Clay Working Machines:

- H - Hammer Mills
- Rotary Kilns
- Beater Mills
- Breakers
- Ball Mills
- Brick Presses
- Tup Mills

##### Textile Machines:

- M - Printing and Dyeing Machines
- Looms
- Willow
- Batchers
- Tanning Vats

##### Oil Industry:

- M - Pipeline Pumps
- Rotary Drilling Equipment

##### Food Industry:

- M - Cane Knives
- Cane Crushers
- Mach Tubs
- H - Cane Mills

##### Laundries:

- M - Tumblers
- Washing Machines

##### Metal Rolling Mills:

- M - Roller Adjustment Drives
- Roller Straightened
- Winding Machines
- Wire Drawing Benches
- H - Billet Shears
- Rotary Tables (heavy)
- Descaling Machines,
- Sheet Mills
- Manipulators
- Cold Rolling Mills

#### Belastungsart

##### Krananlagen:

- U - Einziehwerke
- Hubwerke
- M - Schwenkwerke
- Wippwerke
- H - Fahrwerke

##### Pumpen:

- U - Kreiselpumpen (leichte Flüssigkeit)
- M - Kreiselpumpen (zahe Flüssigkeit)
- H - Prebpumpen
- Plungerpumpen

##### Stein- und Erdebearbeitende Maschine

- H - Hammermühlen
- Drehofen
- Schlagmühlen
- Brecher
- Kugelmühlen
- Ziegelpressen
- Rohrmühlen

##### Textilmaschinen:

- M - Drukerei
- Farbereimachinen
- Aufwickler
- Webstuhle
- Gerbfasser
- Reibwolfe

##### Erdölgewinnung:

- M - Pipeline Pumpen
- Rotative Bohranlagen

##### Nahrungsmittelmachinen:

- M - Rohrschneiden
- Knetmaschinen
- Maichen
- H - Rohrmühlen

##### Waschereimaschinen:

- M - Trommeltrockner
- Waschmaschinen

##### Wälzwerke:

- M - Rollenrichtmaschinen
- Walzenantriebe
- Drahtzuge
- Haspeln
- H - Blechscheren
- Rollgänge (schwer)
- Knüppelscheren
- Schöpfscheren
- Stranggubanlagen
- Kaltwälzwerke

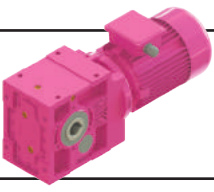

# Genel Bilgiler

## General Information

### Einführung



#### İnşaat Makinaları:

- M - Beton Mikserleri  
- Ağır Yük Asansörleri

#### Kağıt Makinaları:

- H - Islak Presler  
- Kağıt Hamur Makinaları  
- Kurutma Silindirleri  
- Perdahlama Silindirleri

#### Kauçuk Makinaları:

- M - Kalenderler  
- Mikserler  
H - Extruderler  
- Hamur Karma  
- Silindirler

#### Kimya Sanayi:

- M - Agidatörler (yarı sıvı)  
- Kurutma Merdaneleri  
- Mikserler ve Silindirleri

#### Konveyörler:

- M - Bant Ceppli Konveyörler  
- Çelik Bantlı Konveyörler  
- Dökme Yüklü Kayışlı Konv.  
H - Yük Asansörleri  
- Parça Yüklü Kayışlı Konv.

#### Building Machines:

- M - Concrete Mixers  
- Hoist

#### Paper Machines:

- H - Wet Presses  
- Pulpers  
- Drying Cylinders  
- Glazing Cylinders

#### Rubber Machinery:

- M - Calenders  
- Mixers  
H - Extruders  
- Pug Mills  
- Rolling Mills

#### Chemical Ind.:

- M - Aggidators (semi-liquid)  
- Drying Drums.  
- Mixers and Rolling Mills

#### Conveyors:

- M - Band Pocket Conveyors  
- Steel Belt Conveyors  
- Belt Conveyors  
H - Hoists  
- Bulk Belt Conveyors

#### Baumaschinen:

- M - Betonmischermaschinen  
- Bauaufzüge

#### Papiermaschinen:

- H - Naßpressen  
- Gautschen  
- Trockenzyylinder  
- Glattzyylinder

#### Kunststoffmaschinen:

- M - Kalender  
- Mischer  
H - Extruder  
- Knetwerke  
- Wälzwerke

#### Chemische Industrie:

- M - Rührwerke (leichte Flüssig.)  
- Trockentrommeln  
- Mischer und Wälzwerke

#### Förderanlagen:

- M - Gurtaschenbecherwerke  
- Stahlbandförderer  
- Gurtbandförderer (Schüttgut)  
H - Schrägaufzüge  
- Gurtbandförderer (Stückgut)

U	<b>Uniform Yük</b> Uniform Loads Gleichförmige Last	$F_i < 0,25$
M	<b>Orta Darbeli Yük</b> Moderate Loads Ungleichförmige Last	$F_i < 3$
H	<b>Darbeli Yük</b> Heavy Shock Loads Stark Ungleichförmige Last	$F_i < 10$

$$J'_{ext} = \frac{J_{ext}}{i^2}$$

$$F_i = \frac{J'_{ext}}{J_{rotor}}$$

$J'_{ext}$  : **Motor miline indirgenmiş toplam dış atalet momenti**  
External moments of inertia reduced to the motor shaft  
Externe Massenträgheitsmomente reduziert auf Motorwelle

$i$  : **Tahvil oranı**  
Transmission ratio  
Übersetzung

$J_{rotor}$  : **Motorun atalet momenti**  
Moments of inertia to the motor  
Massenträgheitsmoment

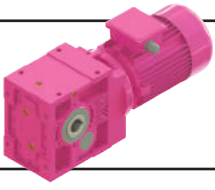

# Genel Bilgiler

## General Information

### Einführung



#### Redüktör Dönüş Yönleri

K Serisi ürünlerimiz için kullanılan yön tanımlaması aşağıdaki gibidir. Aşağıdaki tanımlama kilitli redüktörler için de geçerlidir.

#### Direction of Rotation

K Series direction of rotation of Yılmaz products are defined as follows. The definitions are also valid for gear units with backstop.

#### Getriebedrehrichtungen

Die Drehrichtungen für K Serie Getriebe sind wie folgt definiert. Die Definition ist auch bei Getrieben mit Rücklaufsperrung gültig.

	3-5 Kademe / 3-5 Stages / 3-5 Stufig	2-4-6 Kademe / 2-4-6 Stages / 2-4-6 Stufig
<b>Saat Yönünde</b> Clockwise Rechtslauf  <b>CW</b>		
<b>Saat Tersi Yönünde</b> Counter Clockwise Linkslauf  <b>CCW</b>		

Giriş mili dönüş yönüne göre çıkış mili dönüş yönleri aşağıdaki gibidir.

Output shaft rotation directions according to the input shaft rotation directions are as follows.

Drehrichtungen der Abtriebswelle im Abhängigkeit von der Antriebswellen sind wie folgendes;

3-5 kademe / 3-5 Stages / 3-5 Stufig	2-4-6 Kademe / 2-4-6 Stages / 2-4-6 Stufig

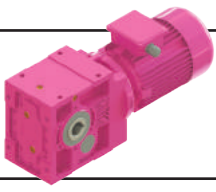

# Genel Bilgiler

## General Information

### Einführung



### Radyal Yükler

Çıkış miline gelebilecek radyal yükler yatak ömrüne göre belirlenmiş ve tablo halinde verilmiştir. Bu tabloda verilen  $F_{qam}$  güvenilir radyal yükü  $f_s=1$  şartı ve yükün mil ortasını yüklediği durum için verilmiştir. Darbeli yüklerin olması durumunda daha önce verilmiş olan servis faktörü tablosundaki değerler dikkate alınmalıdır. Güvenilir aksiyal yük ( $F_{ama}$  veya  $F_{ame}$ ) verilen güvenilir radyal yükün ( $F_{qam}$  veya  $F_{qem}$ ) %25'i kadar alınır. Verilen radyal ve eksenel yükler kuvvetin en kötü açı şartında etki ettiği durum için verilmiştir. Mil ortasına gelen kuvvetin açısına göre daha yüksek radyal yükler mümkündür (Firmamıza danışınız). Bağlantı şekline göre oluşan radyal yük  $F_q$  sayfa 21 de verilen formüller yardımı ile hesaplanır. Redüktör seçiminde ;

$$\begin{aligned} F_{qa} &\leq F_{qam} \\ F_{qe} &\leq F_{qem} \end{aligned}$$

şartı göz önünde tutulmalı. Eğer etkiyen radyal kuvvet milin orta noktasında değil ise verilen güvenilir değer in aşağıda verilen formül ile düzeltilmesi gerekir.

$$\begin{aligned} F_{qam}' &= F_{qam} \times \frac{t}{y+u} \\ F_{qem}' &= F_{qem} \times \frac{t}{y+u} \end{aligned}$$

"t", "y" Değerleri aşağıda verilmiştir. "u" Değeri görüldüğü gibi kuvvetin uygulama noktasıdır.

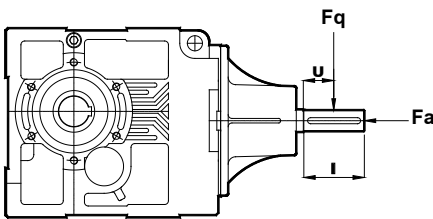
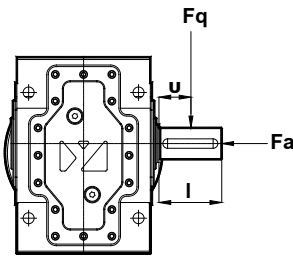

### Overhung Loads

The permissible overhung loads are calculated by considering working life and is listed on the tables. The given permissible overhung loads  $F_{qam}$  are based on  $f_s=1$  and are valid for forces which are applied to the midpoint of the shaft. For shock loading applications the service factor given on the table must take into consideration. The permissible axial load ( $F_{ama}$  or  $F_{ame}$ ) is %25 x ( $F_{qam}$  or  $F_{qem}$ ). The listed permissible overhung loads are based on the worst loading direction. Higher overhung loads can be applied for different loading directions (Please ask if requested). The effective overhung load at the gear box shaft  $F_q$  will be determined with the given formulas on page 21. In Selection ;

$$\begin{aligned} F_{qa} &\leq F_{qam} \\ F_{qe} &\leq F_{qem} \end{aligned}$$

these formulas must be taken into consideration. If the load is not applied at the midpoint of the shaft; the given permissible load must be corrected with the following formulas.

$$\begin{aligned} F_{qam}' &= F_{qam} \times \frac{t}{y+u} \\ F_{qem}' &= F_{qem} \times \frac{t}{y+u} \end{aligned}$$

The values "t", "y" can be taken from the below table. The value "u" is the length of the application point as shown below.

### Querkräfte

Die in den nachfolgenden Tabellen angegebenen zulässigen Radialbelastungen  $F_{qam}$  gelten bei Kraftangriff auf die Mitte Wellenendes. Den Angaben liegt der Betriebsfaktor  $f_s=1$  zu Grunde. Bei stoßartigen Belastungsfällen ist auch hier der entsprechende Betriebsfaktor zu berücksichtigen. Zulässige Axialkräfte  $F_{ama}$  oder  $F_{ame}$  können ohne weitere Nachrechnung bis zu einer Höhe von ca. 25% der zulässigen Radialbelastung  $F_{qam}$  oder  $F_{qem}$  aufgenommen werden. Bei der Ermittlung der zulässige Querkräfte sind höhere Werte möglich (Bitte Rückfragen). Die auftretende Querkräfte  $F_q$  ab der Getriebewelle wird wie in der nachfolgenden Formel bestimmt.

Bei dieser Auswahl;

$$\begin{aligned} F_{qa} &\leq F_{qam} \\ F_{qe} &\leq F_{qem} \end{aligned}$$

müssen die oben angegebenen Bedingungen berücksichtigt werden. Ist der Kraftangriff nicht auf Wellenmitte, so kann die zulässige Querkräfte mit Hilfe der unten stehenden Formel auf jede beliebige Stelle umgerechnet werden.

$$\begin{aligned} F_{qam}' &= F_{qam} \times \frac{t}{y+u} \\ F_{qem}' &= F_{qem} \times \frac{t}{y+u} \end{aligned}$$

Die Werte "t" und "y" sind in den nachfolgenden Tabellen angegeben. Der Wert "u" ist die Stelle des Kraftangriffs wie auf der nächsten Seite angegeben.

KR...01										
Çıkış mili radyal kuvvet hesabı düzeltme katsayıları										
Overhung Load correcting values on output shaft										
Querkräfte auf Ausgangswelle Korrigierungszahlen										
Tip Type Typ	KR..002 KR..003	KR..102 KR..103	KR..202 KR..203	KR..273	KR..373	KR..473	KR..573	KR..673	KR..773	KR..873
t	119	134	156	162	199	236	273	344	408	485
y	99	104	121	132	159	186	213	274	323	380
l	40	60	70	60	80	100	120	140	170	210

KT...										
Giriş mili Radyal kuvvet hesabı düzeltme katsayıları										
Overhung load correcting values on input shaft										
Querkräfte auf Eingangswelle korrigierungszahlen										
Tip Type Typ	KT..002 KT..003	KT..102 KT..103	KT..202 KT..203	KT..273	KT..373	KT..473	KT..573	KT..673	KT..773	KT..873
t	78	78	111	111	126	137	158	180	207	220
y	58	58	86	86	96	102	113	130	147	165
l	40	40	50	50	60	70	90	100	120	110

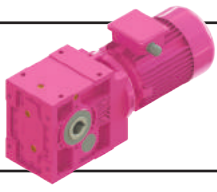

# Genel Bilgiler

## General Information

### Einführung



#### Radyal Yüklerin Hesabı

#### Calc. Of Overhung Loads

#### Berechnung der Querkräfte

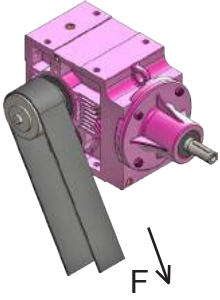

Radyal Yük  $F_q$  [N]'nin hesaplanması da, gerekli tahrik momenti  $M$  [Nm], kasnak veya dişli çapı  $D$  [mm] olmak üzere aşağıdaki formüller kullanılır.

Radial Load  $F_q$  [N] is calculated with the following equations where required moment  $M$  [Nm] and hoop or gear diameter  $D$  [mm] is used.

Der Fall der radialen Belastung  $F_q$  [N] kann mit den angegebenen Gleichungen berechnet werden. Antriebsmoment  $M$  [Nm] und Zahnrad- oder Riemenscheiben Durchmesser  $D$  [mm].



#### 1. Elastik Kaplin

Çalışma sırasında oluşan sapmalar kaplinin güvenlik sınırları içinde ise kuvvetler ihmal edilebilir.

#### 1. Elastic Coupling

If Elastic Coupling is working in its reliable working area, the overhung loads can be neglected.

#### 1. Elastische Kupplung

Wenn die elastische Kupplung in ihrem zulässigen Arbeitsbereich arbeitet, können die radialen Belastungen vernachlässigt werden.



#### 2. Düz Dişli (20° kavrama açısı)

$$F_q = \frac{2100 \times M_2}{D}$$

#### 2. For Spur Gear (Pressure angle 20°)

$$F_q = \frac{2100 \times M_2}{D}$$

#### 2. Stirnradgetriebe (Angriffswinkel 20°)

$$F_q = \frac{2100 \times M_2}{D}$$



#### 3. Küçük Hızlarda Zincir Dişli ( $z > 17$ )

$$F_q = \frac{2100 \times M_2}{D}$$

#### 3. For Chain Drive With Low Speed ( $z > 17$ )

$$F_q = \frac{2100 \times M_2}{D}$$

#### 3. Kettenantrieb mit niedriger Geschwindigkeit ( $z > 17$ )

$$F_q = \frac{2100 \times M_2}{D}$$



#### 4. Triger Kayış

$$F_q = \frac{2500 \times M_2}{D}$$

#### 4. For Triger Belt

$$F_q = \frac{2500 \times M_2}{D}$$

#### 4. Zahnriemenantrieb

$$F_q = \frac{2500 \times M_2}{D}$$



#### 5. V Kayış

$$F_q = \frac{5000 \times M_2}{D}$$

#### 5. For V Belt

$$F_q = \frac{5000 \times M_2}{D}$$

#### 5. Keilriemenantrieb

$$F_q = \frac{5000 \times M_2}{D}$$



#### 6. Gerdirme Makaralı Kayış

$$F_q = \frac{5000 \times M_2}{D}$$

#### 6. Flat Belt With Spanning Pulley

$$F_q = \frac{5000 \times M_2}{D}$$

#### 6. Flachriemenantrieb mit Spannungstrommel

$$F_q = \frac{5000 \times M_2}{D}$$

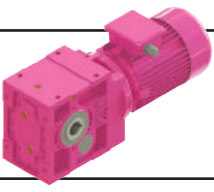

# Genel Bilgiler

## General Information

### Einführung



### Ekstruder Tiplerde Müsade Edilebilir Eksenal Yükler

Permissible Axial Loads for Extruder Types  
Zulässige Axialkräfte für Extruder Typ Getriebe

KRE273					
n <sub>2</sub>	F <sub>ama</sub> [kN]				
	Ömür / Lifetime / Lebensdauer Lh [saat] / [hour] / [Stunde]				
	40000	20000	10000	5000	
20	27.0	33.3	41.0	50.5	
30	23.9	29.5	36.3	44.7	
40	22.0	27.0	33.3	41.0	
50	20.5	25.3	31.1	38.4	
65	19.0	23.4	28.8	35.5	
80	17.8	22.0	27.0	33.3	
100	16.7	20.5	25.3	31.1	
120	15.8	19.4	23.9	29.5	
140	15.1	18.6	22.9	28.2	
160	14.5	17.8	22.0	27.0	
180	14.0	17.2	21.2	26.1	
200	13.5	16.7	20.5	25.3	
220	13.2	16.2	20.0	24.6	
240	12.8	15.8	19.4	23.9	
260	12.5	15.4	19.0	23.4	
280	12.2	15.1	18.6	22.9	
300	12.0	14.8	18.2	22.4	
320	11.8	14.5	17.8	22.0	

n<sub>2</sub> : Çıkış Devri [d/dak]  
Output Speed [rpm]  
Abtriebsdrehzahl [U/min]

KRE373					
n <sub>2</sub>	F <sub>ama</sub> [kN]				
	Ömür / Lifetime / Lebensdauer Lh [saat] / [hour] / [Stunde]				
	40000	20000	10000	5000	
20	104.8	129.0	158.8	195.6	
30	92.7	114.2	140.6	173.2	
40	85.1	104.8	129.0	158.8	
50	79.6	98.0	120.6	148.5	
65	73.5	90.5	111.5	137.3	
80	69.1	85.1	104.8	129.0	
100	64.6	79.6	98.0	120.6	
120	61.2	75.3	92.7	114.2	
140	58.4	71.9	88.5	109.0	
160	56.1	69.1	85.1	104.8	
180	54.2	66.7	82.1	101.1	
200	52.5	64.6	79.6	98.0	
220	51.0	62.8	77.3	95.2	
240	49.7	61.2	75.3	92.7	
260	48.5	59.7	73.5	90.5	
280	47.4	58.4	71.9	88.5	
300	46.5	57.2	70.4	86.7	
320	45.6	56.1	69.1	85.1	

n<sub>2</sub> : Çıkış Devri [d/dak]  
Output Speed [rpm]  
Abtriebsdrehzahl [U/min]

KRE473					
n <sub>2</sub>	F <sub>ama</sub> [kN]				
	Ömür / Lifetime / Lebensdauer Lh [saat] / [hour] / [Stunde]				
	40000	20000	10000	5000	
20	134.5	165.6	203.9	251.1	
30	119.0	146.6	180.5	222.3	
40	109.2	134.5	165.6	203.9	
50	102.1	125.7	154.8	190.7	
65	94.4	116.2	143.1	176.2	
80	88.7	109.2	134.5	165.6	
100	82.9	102.1	125.7	154.8	
120	78.5	96.7	119.0	146.6	
140	75.0	92.3	113.7	140.0	
160	72.0	88.7	109.2	134.5	
180	69.5	85.6	105.4	129.8	
200	67.3	82.9	102.1	125.7	
220	65.4	80.6	99.2	122.2	
240	63.8	78.5	96.7	119.0	
260	62.2	76.6	94.4	116.2	
280	60.9	75.0	92.3	113.7	
300	59.6	73.4	90.4	111.3	
320	58.5	72.0	88.7	109.2	

n<sub>2</sub> : Çıkış Devri [d/dak]  
Output Speed [rpm]  
Abtriebsdrehzahl [U/min]

KRE573					
n <sub>2</sub>	F <sub>ama</sub> [kN]				
	Ömür / Lifetime / Lebensdauer Lh [saat] / [hour] / [Stunde]				
	40000	20000	10000	5000	
20	172.0	211.8	260.8	779.6	
30	152.3	187.5	230.9	715.9	
40	139.7	172.0	211.8	673.9	
50	130.6	160.8	198.1	643.1	
65	120.7	148.7	183.0	608.6	
80	113.4	139.7	172.0	582.6	
100	106.1	130.6	160.8	555.9	
120	100.4	123.7	152.3	535.0	
140	95.9	118.1	145.4	518.0	
160	92.1	113.4	139.7	503.6	
180	88.9	109.5	134.8	491.3	
200	86.1	106.1	130.6	480.6	
220	83.7	103.1	126.9	471.0	
240	81.5	100.4	123.7	462.5	
260	79.6	98.0	120.7	454.8	
280	77.9	95.9	118.1	447.8	
300	76.3	93.9	115.6	441.3	
320	74.8	92.1	113.4	435.4	

n<sub>2</sub> : Çıkış Devri [d/dak]  
Output Speed [rpm]  
Abtriebsdrehzahl [U/min]

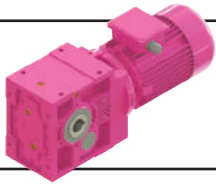

# Genel Bilgiler

## General Information

### Einführung



### Ekstruder Tiplerde Müsade Edilebilir Eksenel Yükler

Permissible Axial Loads for Extruder Types  
Zulässige Axialkräfte für Extruder Typ Getrieben

KRE673				
n <sub>2</sub>	F <sub>ama</sub> [kN]			
	Ömür / Lifetime / Lebensdauer Lh [saat] / [hour] / [Stunde]			
	40000	20000	10000	5000
20	209.5	258.0	317.7	391.2
30	185.5	228.4	281.3	346.4
40	170.1	209.5	258.0	317.7
50	159.1	195.9	241.3	297.1
65	147.1	181.1	223.0	274.6
80	138.2	170.1	209.5	258.0
100	129.2	159.1	195.9	241.3
120	122.3	150.6	185.5	228.4
140	116.8	143.8	177.1	218.1
160	112.2	138.2	170.1	209.5
180	108.3	133.4	164.2	202.2
200	104.9	129.2	159.1	195.9
220	102.0	125.6	154.6	190.4
240	99.3	122.3	150.6	185.5
260	97.0	119.4	147.1	181.1
280	94.8	116.8	143.8	177.1
300	92.9	114.4	140.9	173.5
320	91.1	112.2	138.2	170.1

n<sub>2</sub> : Çıkış Devri [d/dak]  
Output Speed [rpm]  
Abtriebsdrehzahl [U/min]

KR773				
n <sub>2</sub>	F <sub>ama</sub> [kN]			
	Ömür / Lifetime / Lebensdauer Lh [saat] / [hour] / [Stunde]			
	40000	20000	10000	5000
20	350.2	431.3	531.1	653.9
30	310.1	381.8	470.2	579.0
40	284.4	350.2	431.3	531.1
50	266.0	327.5	403.3	496.6
65	245.8	302.7	372.8	459.0
80	231.0	284.4	350.2	431.3
100	216.0	266.0	327.5	403.3
120	204.5	251.8	310.1	381.8
140	195.2	240.4	296.0	364.5
160	187.6	231.0	284.4	350.2
180	181.0	222.9	274.5	338.0
200	175.4	216.0	266.0	327.5
220	170.5	209.9	258.5	318.3
240	166.1	204.5	251.8	310.1
260	162.1	199.6	245.8	302.7
280	158.5	195.2	240.4	296.0
300	155.3	191.2	235.5	290.0
320	152.3	187.6	231.0	284.4

n<sub>2</sub> : Çıkış Devri [d/dak]  
Output Speed [rpm]  
Abtriebsdrehzahl [U/min]

KRE873				
n <sub>2</sub>	F <sub>ama</sub> [kN]			
	Ömür / Lifetime / Lebensdauer Lh [saat] / [hour] / [Stunde]			
	40000	20000	10000	5000
20	403.4	496.7	611.7	753.2
30	357.1	439.8	541.5	666.9
40	327.6	403.4	496.7	611.7
50	306.3	377.2	464.5	572.0
65	283.1	348.7	429.3	528.7
80	266.0	327.6	403.4	496.7
100	248.8	306.3	377.2	464.5
120	235.5	290.0	357.1	439.8
140	224.9	276.9	341.0	419.9
160	216.0	266.0	327.6	403.4
180	208.5	256.8	316.2	389.4
200	202.0	248.8	306.3	377.2
220	196.3	241.8	297.7	366.6
240	191.3	235.5	290.0	357.1
260	186.7	229.9	283.1	348.7
280	182.6	224.9	276.9	341.0
300	178.9	220.3	271.2	334.0
320	175.4	216.0	266.0	327.6

n<sub>2</sub> : Çıkış Devri [d/dak]  
Output Speed [rpm]  
Abtriebsdrehzahl [U/min]

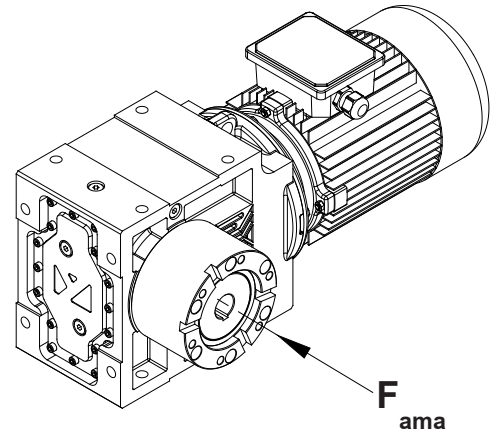

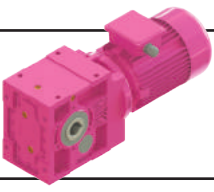

# Genel Bilgiler

## General Information

### Einführung



### Eşdeğer Güç Hesabı

Sabit devirde, ancak değişken momentlerde (güçlerde) çalışan redüktörler için eşdeğer tork altındaki, eşdeğer güç hesaplanabilir. Bu eşdeğer güç kullanılarak bilinen sabit güçteki redüktör seçim yöntemi kullanılarak seçim yapılabilir. Burada ağırlıklı torka göre eşdeğer anma torku belirlenmektedir. Hesaplanan bu güçte çalışan redüktör, teorik olarak, değişken yüklerde çalışan redüktör ile aynı emniyet değerine ve ömre sahiptir.

Bir çevrim boyunca oluşan değişken torklar, en yüksek torktan, en düşüğe doğru yatay zaman eksenini boyunca sıralanır (bakınız alttaki şekil). Bu şekile göre eşdeğer tork şu formül ile hesaplanır;

$$T_e = \left( \frac{\Delta t_1 \times T_1^{6.6} + \dots + \Delta t_n \times T_n^{6.6}}{t} \right)^{\frac{1}{6.6}}$$

Eğer  $T_n$  değerleri (en düşük tork),  $T_e$ 'nin 0,5 katının altında ise, bu tork dilimi yok sayılarak, işlem tekrarlanır;

Eğer  $T_n < T_e \times 0.5$  ise

$$T_e = \left( \frac{\Delta t_1 \times T_1^{6.6} + \dots + \Delta t_{n-1} \times T_{n-1}^{6.6}}{t - \Delta t_n} \right)^{\frac{1}{6.6}}$$

Tüm  $T_n$  değerleri  $T_e$ 'nin 0,5 katının üzerinde ise, eşdeğer güç aşağıdaki gibi hesaplanır;

$$P_{eq} = P_N = \frac{T_e \times n}{9550}$$

Eşdeğer gücün bulunmasından sonra eşdeğer güç değeri kullanılarak, bu katalogta verilen redüktör seçimi bölümünde anlatılan adımlar uygulanarak redüktör seçimi tamamlanır.

### Equivalent Power Rating Calculation

The equivalent power by an equivalent constant torque can be calculated for gearboxes working in constant speed but variable torques (or powers). Using this equivalent power it is possible to make a gearbox selection according to the usual gearbox selection method with constant torques. The equivalent torque will be determined according to the mean of dominating torques. The gearbox working in constant equivalent torque will theoretically have the same lifetime and safety compared to the variable torque one.

To calculate the equivalent torques, the variable torques in a cycle must be sorted from the maximal to the minimal on a horizontal time line (Check the graphic below). According to the graphic below the equivalent torque can be calculated with the following formula;

$$T_e = \left( \frac{\Delta t_1 \times T_1^{6.6} + \dots + \Delta t_n \times T_n^{6.6}}{t} \right)^{\frac{1}{6.6}}$$

If  $T_n$  (the lowest torque) is lower than 50 % of  $T_e$ , this torque part must be taken out of the torque graph and the calculation must be repeated;

If  $T_n < T_e \times 0.5$  then

$$T_e = \left( \frac{\Delta t_1 \times T_1^{6.6} + \dots + \Delta t_{n-1} \times T_{n-1}^{6.6}}{t - \Delta t_n} \right)^{\frac{1}{6.6}}$$

If all  $T_n$  values are higher than 50% of  $T_e$  then the equivalent power can be calculated by the following formula;

$$P_{eq} = P_N = \frac{T_e \times n}{9550}$$

After the equivalent power is determined the selection of gearbox is made according to the selection procedures given on the gearbox selection part in this catalogue.

### Berechnung Äquivalenter Leistung

Die äquivalente Leistung bei äquivalenten Drehmoment kann für Getrieben mit konstanten Drehzahl und variablen Momente berechnet werden. Mit dieser Leistung kann das Getriebe ausgelegt werden, wie bei konstanten Leistung. Man bestimmt hiermit also die maßgebende Belastung. Das ausgelegte Getriebe erreicht theoretisch dem gleichen Lebensdauer und hat die gleiche Sicherheit.

Für die Berechnung der äquivalenten Drehmoment müssen die einzelnen Drehmomentanteile auf eine Zeitachse von größten bis zu kleinsten angeordnet werden (siehe unteres Bild). Das äquivalente Drehmoment wird nach folgender Formel berechnet;

$$T_e = \left( \frac{\Delta t_1 \times T_1^{6.6} + \dots + \Delta t_n \times T_n^{6.6}}{t} \right)^{\frac{1}{6.6}}$$

Wenn  $T_n$  (niedrigstes Drehmoment) kleiner als 50% von  $T_e$  ist, muss dieser Anteil vernachlässigt werden und die Berechnung soll neu durchgeführt werden;

Wenn  $T_n < T_e \times 0.5$  dann

$$T_e = \left( \frac{\Delta t_1 \times T_1^{6.6} + \dots + \Delta t_{n-1} \times T_{n-1}^{6.6}}{t - \Delta t_n} \right)^{\frac{1}{6.6}}$$

Wenn alle  $T_n$  Werte höher als 50% von  $T_e$  sind, dann wird die äquivalente Leistung nach folgender Formel berechnet;

$$P_{eq} = P_N = \frac{T_e \times n}{9550}$$

Nach Bestimmung der äquivalenten Leistung, erfolgt die Getriebeauslegung wie bei konstanter Leistung. Die Auswahlverfahren für konstante Leistung ist in diesem Katalog angegeben.

(Moment / Torque / Moment)

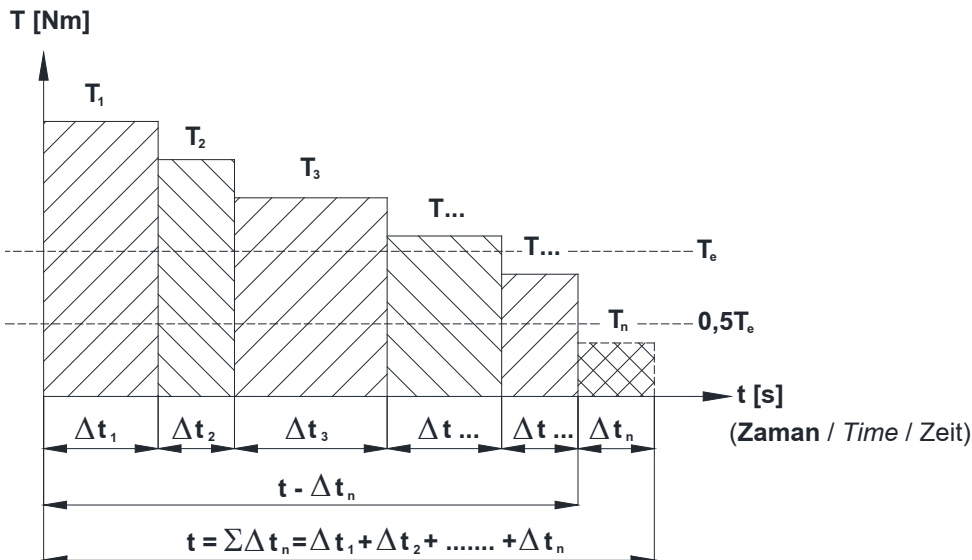

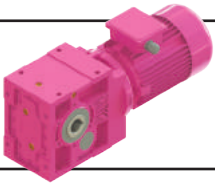

# Genel Bilgiler

## General Information

### Einführung



#### Eşdeğer Güç Hesabı Örneği

Çift yönlü çalışan ham demir haddesi için aşağıdaki çalışma koşulları belirlenmiş;

##### Veriler:

Toplam bir iş çevrimi: 2 dak.

1. Yük kademesi: 48 kNm, 30 sn
2. Yük Kademesi: 32 kNm, 22 sn
3. Yük Kademesi: 28 kNm, 15 sn
4. Yük Kademesi: 16 kNm, 10 sn
5. Yük Kademesi: 5 kNm, 43sn

Makina sabit devri: 50 d/dak

Redüktör seçimine esas olacak eşdeğer yük aranmaktadır.

##### Çözüm:

Bir çevrimin toplam zamanı;

$$t = t_1 + t_2 + t_3 + t_4 + t_5 = 120 \text{ sn}$$

Eşdeğer Tork;

$$T_e = \left( \frac{30 \times 48^{6,6} + \dots + 43 \times 5^{6,6}}{120} \right)^{\frac{1}{6,6}}$$

$$= 39,2 \text{ kNm}$$

%50 eşdeğer tork;

$$0,5 \times T_e = 19,6 \text{ kNm}$$

Her bir tork dilimi bu değer üzerinde olmalı

$$T_{4,5} < 0,5 \times T_e$$

%50 torkun altındakileri çıkararak hesabı tekrarlayalım;

$$t' = t_1 - t_4 - t_5 = 120 - 43 - 10 = 67 \text{ s}$$

$$T_e = \left( \frac{30 \times 48^{6,6} + 22 \times 32^{6,6} + 15 \times 28^{6,6}}{67} \right)^{\frac{1}{6,6}}$$

$$= 42,9 \text{ kNm}$$

Moment ve devir değerlerini kullanarak eşdeğer gücümüzü hesaplayalım;

$$P_{eq} = \frac{T_e \times n}{9550} = \frac{42,9 \times 1000 \times 50}{9550} = 225 \text{ kW}$$

Yukarıdaki güç ve devir değeri kullanılarak bu katalogta anlatılan seçim prosedürü ile redüktör seçimi yapılabilir.

#### Equivalent Power Rating Sample

The following data is given for a reversing blooming mill;

##### Torque steps:

Total one cycle time: 2 min.

- 1st torque part: 48 kNm, 30 s
- 2nd torque part: 32 kNm, 22 s
- 3th torque part: 28 kNm, 15 s
- 4th torque part: 16 kNm, 10 s
- 5th torque part: 5 kNm, 43 s

Machine constant speed: 50 rpm

The equivalent power, which is required for gear unit selection, is to determine.

##### Solution:

Total time in a cycle;

$$t = t_1 + t_2 + t_3 + t_4 + t_5 = 120 \text{ sn}$$

Equivalent Torque;

$$T_e = \left( \frac{30 \times 48^{6,6} + \dots + 43 \times 5^{6,6}}{120} \right)^{\frac{1}{6,6}}$$

$$= 39,2 \text{ kNm}$$

50% of Equivalent torque;

$$0,5 \times T_e = 19,6 \text{ kNm}$$

Every torque part must be lower then this value;

$$T_{4,5} < 0,5 \times T_e$$

We are repeating the calculation by taking out the torque parts, which are below 50%;

$$t' = t_1 - t_4 - t_5 = 120 - 43 - 10 = 67 \text{ s}$$

$$T_e = \left( \frac{30 \times 48^{6,6} + 22 \times 32^{6,6} + 15 \times 28^{6,6}}{67} \right)^{\frac{1}{6,6}}$$

$$= 42,9 \text{ kNm}$$

By using the equivalent torque and constant speed we calculate the equivalent power;

$$P_{eq} = \frac{T_e \times n}{9550} = \frac{42,9 \times 1000 \times 50}{9550} = 225 \text{ kW}$$

Now by using the above calculated equivalent power and constant speed we camake the gear-box selection with the procedures described in this catalogue.

#### Beispiel für Äquivalente Leistung

Die nachfolgenden Angaben sind für eine Blechreversierwalze;

##### Drehmoment stufen:

Gesamte Zeit für einem Arbeitszyklus: 2 min.

- Drehmomentanteil 1: 48 kNm 30 s
- Drehmomentanteil 2: 32 kNm 22 s
- Drehmomentanteil 3: 28 kNm 15 s
- Drehmomentanteil 4: 16 kNm 10 s
- Drehmomentanteil 5: 5 kNm 43 s

Maschine hat konstante Drehzahl: 50 U/min

Gesucht ist die äquivalente Leistung, die für die Getriebeauslegung nötig ist.

##### Lösung:

Gesamte Zeit für einem Arbeitszyklus;

$$t = t_1 + t_2 + t_3 + t_4 + t_5 = 120 \text{ sn}$$

Äquivalentes Drehmoment;

$$T_e = \left( \frac{30 \times 48^{6,6} + \dots + 43 \times 5^{6,6}}{120} \right)^{\frac{1}{6,6}}$$

$$= 39,2 \text{ kNm}$$

50% von äquivalenten Drehmoment;

$$0,5 \times T_e = 19,6 \text{ kNm}$$

Drehmomentanteile müssen größer als dieser Wert sein;

$$T_{4,5} < 0,5 \times T_e$$

Wir wiederholen die Berechnung nochmals ohne die kleine Drehmomentanteile;

$$t' = t_1 - t_4 - t_5 = 120 - 43 - 10 = 67 \text{ s}$$

$$T_e = \left( \frac{30 \times 48^{6,6} + 22 \times 32^{6,6} + 15 \times 28^{6,6}}{67} \right)^{\frac{1}{6,6}}$$

$$= 42,9 \text{ kNm}$$

Mit Hilfe von äquivalenten Drehmoment und konstanter Drehzahl berechnet man die äquivalente Leistung;

$$P_{eq} = \frac{T_e \times n}{9550} = \frac{42,9 \times 1000 \times 50}{9550} = 225 \text{ kW}$$

Nach Bestimmung der äquivalente Leistung und konstanter Drehzahl, erfolgt die Getriebeauslegung dann wie die Getriebeauswahl gemäß dem in diesem Katalog beschriebenen Verfahren für konstante Leistung.

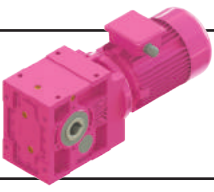

# Genel Bilgiler

## General Information

### Einführung



#### Redüktör Seçimi

Bir redüktör seçiminde aşağıdaki yol izlenmelidir.

1. Çalışma şartlarına bağlı olarak servis faktörünü (fs) belirleyiniz. (Servis Faktörü Sayfa 16).

2. Makinanız için gerekli olan momenti belirleyiniz  $M_2$  (redüktör gerekli çıkış momenti ).

3. Makinanızın devrini belirleyiniz  $n_2$  (redüktör gerekli çıkış devri ).

4. Makinanızın güç ihtiyacını (Redüktör çıkış gücünü) " $P_2$ " hesaplayınız.

$$P_2 = \frac{M_2 \times n_2}{9550}$$

5. Redüktör ile makina arasında kullanılan bağlantı elemanına göre radyal yükü hesaplayınız. (Sayfa 20). Yukarıdaki verilere uygun olarak çıkış devri, değerlerine uyan servis faktörü ve radyal yükü bulduğunuzdan daha yüksek veya eşit olan redüktörü, güç-devir seçim tablolarından seçiniz. Helisel tip redüktörlerde verim yüksek olduğundan çıkış gücü verilmemiştir. Hesapladığınız güç değerini giriş gücü olarak kabul edip seçiminizi yapınız. Tablolarda verilen  $M_2$  çıkış momentinin hesapladığınız  $M_2$  den büyük olmasına dikkat ediniz. Eğer seçilen redüktörünki daha ufak ise bir üst motor gücüne geçiniz.

#### Örnek

##### 1. Makina Cinsi:

Lastik bantlı konveyör , dökme yük taşıyor.

##### 2. Makina için gerekli moment:

Makina için hesaplanan moment  $M_2 = 470$  Nm.

##### 3. Makina gerekli çıkış devri:

$n_2 = 50$  dev/dak.

##### 4. Günlük çalışma süresi:

16 saat.

##### 5. Saatte start sayısı:

Saatte 1 start

##### 6. Makina ile bağlantı şekli:

Zincir dişli ( çap -130 mm )

- Yük sınıflandırma tablosundan yük sınıfı M olarak seçilir (sayfa 17-18)

- Günlük çalışma süresi 16 saat Saatte start sayısı 1 ve yük sınıfı M'ye tekabül eden servis faktörü tablosundan, servis faktörü için  $fs = 1.3$  değeri bulunur.(sayfa 16)

- Makinanızın güç ihtiyacı (Redüktör Çıkış Gücü) :

$$P_2 = \frac{M_2 \times n_2}{9550} = \frac{470 \times 50}{9550} = 2,46 \text{ kW}$$

#### Gearbox Selection

For the correct selection of the appropriate gear units follow this steps.

1.Determine service factor (fs) on the basis of running conditions (Page 16).

2. Determine the required Torque  $M_2$  (required output torque of gearbox) for the driven machine.

3. Determine required speed (output speed of gearbox) for the driven machine.

4. Calculate the required power for your machine(Calculate power " $P_2$ " required at output side of gear reducer using the formula);

$$P_2 = \frac{M_2 \times n_2}{9550}$$

5. Calculate overhung load required at output shaft according to type of connection between gear unit and machine (Refer to directions and values given on page 20). After determining the above mentioned values, the gear reducer which corresponds to our requirements can be selected from the performance tables (the service factor and the permissible overhung load should be less than or equal to our requirement). For Helical gears the output power is not given on the performance tables because they have high efficiency and the output power can be taken as input power. The output torque should be checked if it meets to our requirements. If the output torque is low, search for a higher input power gearbox.

#### Example:

##### 1. Machine Type:

Belt Conveyor (Bulk Load)

##### 2. Required Torque:

Required Torque calculated for the driven machine is  $M_2=470$  Nm.

##### 3. Required speed:

$n_2 = 50$  rpm

##### 4. Running time:

16 hours per day

##### 5. Frequency of starting:

1 start per hour

##### 6. Connection type between gear reducer

Chain drive (output dimension-130 mm)

- From the load classification table (on page 17-18), the load class M can be selected for the known application.

- The service factor can be selected as  $fs = 1,3$  from the service factor table (page 16) by taking into consideration 16 hours running time, one start per hour, and load class M.

-Required power for your machine(Power at output side of gear reducer) :

$$P_2 = \frac{M_2 \times n_2}{9550} = \frac{470 \times 50}{9550} = 2,46 \text{ kW}$$

#### Getriebeauswahl

Für die korrekte Auswahl des Antriebes;

1. Den Betriebsfaktor(fs) in Abhängigkeit von den Betriebsbedingungen bestimmen.(Bezug auf seite 16).

2. Die erforderte Drehmoment  $M_2$  für die angetriebene Maschine (Abtriebsdrehmoment für die Getriebe) bestimmen.

3. Erforderte Drehzahl bestimmen (Abtriebsdrehzahl für die Getriebe).

4. Berechnen der erforderte Leistung der angetriebene Maschine (Die an der Abtriebswelle erforderte Leistung " $P_2$ ") mit der unten angegebenen Formel.

$$P_2 = \frac{M_2 \times n_2}{9550}$$

5. Die an der Getriebeabtriebswelle erforderte Querkraft in Abhängigkeit von Antriebsselement bestimmen (Bezug auf Seite 20). Nach Bestimmen der oben angegebenen Werte, die passende Getriebe kann von den angegebenen Leistungstabellen entnommen werden. Dabei soll darauf geachtet werden, dass der Betriebsfaktor und Querkraft stets unterhalb von angegebenen Werten liegt. Weil Stirnradgetrieben einen hohen Wirkungsgrad haben, sind die Abtriebsleistungen für Stirnradgetrieben nicht angegeben. Bei dieser Getrieben die erforderte Leistung kann als Antriebsleistung benutzt werden. Achten sie darauf, dass der Abtriebsmoment größer als die erforderte Drehmoment ist.

#### Beispiel:

##### 1. Maschinentyp:

Gurtbandförderer (Schüttgut)

##### 2. Erforderte Drehmoment:

Für die Maschine berechnete Drehmoment  $M_2 = 470$  Nm.

##### 3. Erforderte Drehzahl:

$n_2 = 50$  upm

##### 4. Betriebsdauer:

16 stunden pro Tag

##### 5. Schalthäufigkeit:

1 Start pro Stunde

##### 6. Antriebselement für verbindung

Getriebe-Machine:Kettentrieb(Durchmesser-130 mm)

- Von den Belastungsart Tabellen(Seite 17-18) nimmt man Belastungsart M

- Für den Schaltungzahl 1 und die Laufzeit16 und für den passenden Belastungsart erhält man Betriebsfaktor  $fs = 1,3$  von Tabelle auf seite 16.

- Erforderte Leistung der angetriebe Maschine (Die an der Getriebeabtriebswelle erforderte Leistung)

$$P_2 = \frac{M_2 \times n_2}{9550} = \frac{470 \times 50}{9550} = 2,46 \text{ kW}$$

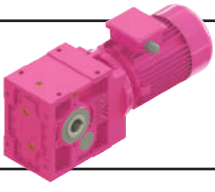

## Genel Bilgiler General Information Einführung



- Zincir dişli uygulaması için (Sayfa 21) Fq değeri;

$$F_q = \frac{2100 \times M_2}{D} = \frac{2100 \times 470}{130} = 7592 \text{ N}$$

- Ortaya çıkan redüktör ihtiyacı

$$\begin{aligned} P_2 &\geq 2,46 \text{ kW} \\ M_2 &\geq 470 \text{ Nm} \\ fs &\geq 1.3 \\ n_2 &\approx 50 \text{ d/dak} \\ Fq &\geq 7592 \text{ N} \end{aligned}$$

Güç ve devir sayılarından,

**KR373-100L/4b** seçilir (Sayfa 72).

$$\begin{aligned} P_2 &= 3 \text{ kW} > 2,46 \text{ kW} \\ M_2 &= 555 \text{ Nm} > 470 \text{ Nm} \\ fs &= 1,5 \\ n_2 &= 49 \text{ d/dak} \\ fq &= 13213 \text{ Nm} < 7592 \text{ Nm} \\ i &= 28,85 \end{aligned}$$

- For chain drive application the requested overhang load can be calculated from (page 21);

$$F_q = \frac{2100 \times M_2}{D} = \frac{2100 \times 470}{130} = 7592 \text{ N}$$

- The required gearbox is as follows:

$$\begin{aligned} P_2 &\geq 2,46 \text{ kW} \\ M_2 &\geq 470 \text{ Nm} \\ fs &\geq 1.3 \\ n_2 &\approx 50 \text{ rpm} \\ Fq &\geq 7592 \text{ N} \end{aligned}$$

From the performance table,

**KR373-100L/4b** selected (Page 72).

$$\begin{aligned} P_2 &= 3 \text{ kW} > 2,46 \text{ kW} \\ M_2 &= 555 \text{ Nm} > 470 \text{ Nm} \\ fs &= 1,5 \\ n_2 &= 49 \text{ rpm} \\ fq &= 13213 \text{ Nm} < 7592 \text{ Nm} \\ i &= 28,85 \end{aligned}$$

- Für Kettentrieb die erforderte Querkraft (seite 21);

$$F_q = \frac{2100 \times M_2}{D} = \frac{2100 \times 470}{130} = 7592 \text{ N}$$

- Von den oben angegebenen Berechnungen die erforderte Getriebe ist wie folgt;

$$\begin{aligned} P_2 &\geq 2,46 \text{ kW} \\ M_2 &\geq 470 \text{ Nm} \\ fs &\geq 1.3 \\ n_2 &\approx 50 \text{ U/min} \\ Fq &\geq 7592 \text{ N} \end{aligned}$$

Von der Leistung- DrehzahlTabelle ,

wurde **KR373-100L/4b** gewählt (Seite 72).

$$\begin{aligned} P_2 &= 3 \text{ kW} > 2,46 \text{ kW} \\ M_2 &= 555 \text{ Nm} > 470 \text{ Nm} \\ fs &= 1,5 \\ n_2 &= 49 \text{ U/min} \\ fq &= 13213 \text{ Nm} < 7592 \text{ Nm} \\ i &= 28,85 \end{aligned}$$

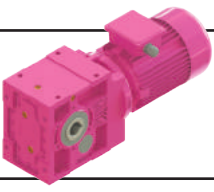

# Genel Bilgiler

## General Information

### Einführung



### Redüktör Seçim Formu

Kullanıldığı Sektör.....  
Kullanıldığı Yer.....  
Gerekli Ortalama Devir.....d/dak

#### Makina ihtiyaç gücü:

-Normal..... kW  
-En çok..... kW  
-En az..... kW

#### Tahrik Şekli:

AC Motor [ ]  
AC Motor + Invertör [ ]  
DC Motor [ ]  
Hidromotor [ ]  
1-3 silindri içten yanmalı [ ]  
2-4 silindri içten yanmalı [ ]

#### Motor Bağlantı Şekli (Elektrik Motorları):

IEC B5 Flanşlı [ ]  
NEMA Flanşlı [ ]

IEC veya NEMA flanş kodu.....

#### Motor Gücü:

-Nominal..... kW

#### Motor Devri:

-Normal..... d/dak  
-En çok..... d/dak  
-En az..... d/dak

#### Motor Torku:

-Normal..... Nm  
-En çok..... Nm  
-En az..... Nm

#### Dönüş şekli:

saat yönü [ ] saat yönüne ters [ ] değişken [ ]

#### Günlük çalışma süresi:

<4 [ ] 4-8 [ ] 8-16 [ ] >16 [ ]

#### Saatteki start sayısı:

0-50 [ ] 50-100 [ ] 100-200 [ ]  
200-300 [ ] 300-500 [ ] 500-700 [ ]  
700-1000 [ ] >1000 [ ]

Motor Redüktör Arası Tahvil Oranı.....

Kalkış için gerekli moment.....Nm

#### Saatteki pik moment adedi:

1-5 [ ] 6-30 [ ] 31-100 [ ] >100 [ ]

#### Bir çevrimde aktif çalışma oranı (ED):

%100 [ ] %80 [ ] %60 [ ] 40% [ ] %20 [ ]

#### Deniz seviyesinden yükseklik:

<1000 [ ] <2000 [ ] <3000 [ ]  
<4000 [ ] <5000 [ ]

#### Montaj yeri:

Küçük kapalı oda (w<1m/sn) [ ]  
Kapalı oda (w<3m/sn) [ ]  
Büyük oda ve holler (w>=3m/sn) [ ]  
Tamamen açık ortam [ ]

#### Çevre Şartları:

Normal [ ] Tozlu [ ] Nemli [ ]  
Korozif [ ] Kuru [ ]

#### Çevre Sıcaklığı:

Ortalama..... °C  
En Yüksek..... °C  
En Düşük..... °C

#### Kilit İhtiyacı:

Var [ ] Yok [ ]

#### Redüktör Giriş Opsiyonu:

R.. [ ] V.. [ ] N.. [ ] T.. [ ]

#### Redüktör Çıkış Opsiyonu:

00 [ ] 01 [ ] 02 [ ] 03 [ ] 04 [ ] 05 [ ] 08 [ ]  
0S [ ] 0E [ ]

#### Montaj Pozisyonu:

M1 [ ] M2 [ ] M3 [ ] M4 [ ] M5 [ ] M6 [ ]

#### Giriş mili bağlantı şekli:

Elastik kaplin [ ]  
Fıçı tipi kaplin [ ]  
Rijit kaplin [ ]  
Hidrolik Kaplin [ ]  
Kayış kasnak [ ]  
Zincir dişli [ ]  
Pinyon dişli [ ]  
Bağlantı elemanı çapı.....mm  
Radyal yükü.....N  
Radyal yük "u" mesafesi.....mm  
Aksiyal yükü (mile doğru +).....N

#### Çıkış mili bağlantı şekli:

Elastik kaplin [ ]  
Fıçı tipi kaplin [ ]  
Rijit kaplin [ ]  
Kayış kasnak [ ]  
Zincir dişli [ ]  
Pinyon dişli [ ]  
Delik milli tork kolu [ ]  
Sıkma bilezikli tork kolu [ ]  
Bağlantı elemanı çapı.....mm  
Radyal yükü.....N  
Radyal yük "u" mesafesi.....mm  
Aksiyal yükü (mile doğru +).....N

#### Çıkış Mili Özelliği:

Dolu Mil Kamalı [ ]  
Dolu Mil Kamasız [ ]  
Delik Milli Sıkma Bilezikli [ ]  
Delik Milli [ ]  
Özel Mil [ ]

#### Giriş Mili Özelliği:

Kamalı [ ]  
Kamasız düz mil [ ]  
Özel Mil [ ]  
Tork kolu [ ] Var [ ] Yok [ ]

#### Elektrik Gerilimi:

AC-Monofaze [ ] AC-Trifaze [ ] DC [ ]  
Voltaj..... Volt  
Frekans..... Hz

#### Koruma Sınıfı:

IP55 [ ] IP65 [ ] Exproof [ ]  
Diğer IP.....

#### Ekler:

Yük diyagramı [ ]  
Proje [ ]  
İstenen ana boyutlar [ ]  
Teknik veriler [ ]

#### Diğer Notlar:

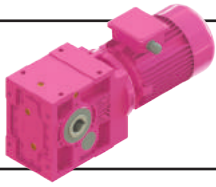

# Genel Bilgiler

## General Information

### Einführung



#### Gearbox Selection Form

Field of Industry.....  
 Application.....  
 Required Average Speed..... rpm

**Required Power on Driven Machine:**  
 -Normal..... kW  
 -Maximum..... kW  
 -Minimum..... kW

**Driving Machine:**  
 AC Motor [ ]  
 AC Motor + Inverter [ ]  
 DC Motor [ ]  
 Hydraulic Motor [ ]  
 Piston Engine with 1-3 cylinder [ ]  
 Piston Engine with 4-24 cylinder [ ]

**Motor Connection Type (Electric Motors):**  
 IEC B5 Flange [ ]  
 NEMA Flange [ ]

IEC or NEMA Flange Code.....

**Motor Power:**  
 -Nominal.....kW

**Motor Speed:**  
 -Normal.....rpm  
 -Maximum.....rpm  
 -Minimum.....rpm

**Motor Torque:**  
 -Normal.....Nm  
 -Maximum.....Nm  
 -Minimum.....Nm

**Direction of Rotation:**  
 cw [ ] ccw [ ] variable [ ]

**Working hours per day:**  
 <4 [ ] 4-8 [ ] 8-16 [ ] >16 [ ]

**Startings per cycle:**  
 0-50 [ ] 50-100 [ ] 100-200 [ ]  
 200-300 [ ] 300-500 [ ] 500-700 [ ]  
 700-1000 [ ] >1000 [ ]

Transmission ratio between motor and gear unit.....

Required Starting Torque.....Nm

**Peak torques per hour:**  
 1-5 [ ] 6-30 [ ] 31-100 [ ] >100 [ ]

**Effective working time in a cycle (ED):**  
 %100 [ ] %80 [ ] %60 [ ] 40% [ ]  
 20% [ ]

**Altitude:**  
 <1000 [ ] <2000 [ ] <3000 [ ]  
 <4000 [ ] <5000 [ ]

**Mounting Place:**  
 Small closed room (w<1m/sn) [ ]  
 Closed room (w<3m/sn) [ ]  
 Big rooms and halls (w>=3m/sn) [ ]  
 Outdoor [ ]

**Ambient Conditions:**  
 Normal [ ] Dusty [ ] Humid [ ]  
 Corrosive [ ] Dry [ ]

**Ambient Temperature:**  
 Average.....°C  
 Maximum.....°C  
 Minimum.....°C

**Backstop Required:**  
 Yes [ ] No [ ]

**Gearbox input options:**  
 R.. [ ] V.. [ ] N.. [ ] T.. [ ]

**Gearbox output options:**  
 00 [ ] 01 [ ] 02 [ ] 03 [ ] 04 [ ] 05 [ ] 08 [ ]  
 0S [ ] 0E [ ]

**Mounting Position:**  
 M1 [ ] M2 [ ] M3 [ ] M4 [ ] M5 [ ] M6 [ ]

**Input Shaft Connection Type:**  
 Elastic Coupling [ ]  
 Barrel Type Coupling [ ]  
 Hydraulic Coupling [ ]  
 Rigid Flange Coupling [ ]  
 Pulley [ ]  
 Chain Sprocket [ ]  
 Pinion [ ]  
 Diameter of Connection element.....mm  
 Radial Load.....N  
 "u" Distance of Radial Load.....mm  
 Axial Load (Towards Shaft) .....N

**Output Shaft Connection Type:**  
 Elastic Coupling [ ]  
 Barrel Type Coupling [ ]  
 Rigid Flange Coupling [ ]  
 Pulley [ ]  
 Chain Sprocket [ ]  
 Pinion [ ]  
 Hollow Shaft with Torque Arm [ ]  
 Shrinco disc with Torque Arm [ ]  
 Diameter of Connection Element.....mm  
 Radial Load.....N  
 "u" Distance of Radial Load.....mm  
 Axial Load (Towards Shaft) .....N

**Gearbox assembled by:**  
 Foot [ ] Flange [ ] Torque Arm [ ]

**Output Shaft Specification:**  
 Solid Shaft with Keyway [ ]  
 Solid Shaft without Keyway [ ]  
 Hollow Shaft with Shrinco Disc [ ]  
 Hollow Shaft [ ]  
 Special Shaft [ ]

**Input Shaft Specification:**  
 Solid Shaft with Keyway [ ]  
 Solid Shaft without Keyway [ ]  
 Special Shaft [ ]  
 Torque arm required Yes [ ] No [ ]

**Electrical Supply:**  
 AC-1 Phase [ ] AC-3 Phase [ ] DC [ ]  
 Voltage.....Volt  
 Frequency..... Hz

**Protection Class:**  
 IP55 [ ] IP65 [ ] Exproof [ ]  
 Other IP.....

**Attachments:**  
 Load Diagram [ ]  
 Project [ ]  
 Required Dimensions [ ]  
 Technical Specifications [ ]

**Notes:**

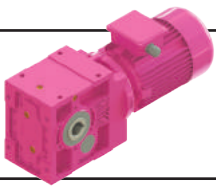

# Genel Bilgiler

## General Information

### Einführung



#### Formular für Getriebeauswahl

Industriebereich.....  
 Anwendung.....  
 Erforderliche Drehzahl.....U/min

#### Erforderliche Leistung für die Maschine:

-Normal.....kW  
 -Minimal.....kW  
 -Maximal.....kW

#### Antriebsmaschine:

AC Motor [ ]  
 AC Motor mit Frequenzumrichter [ ]  
 DC Motor [ ]  
 Hydromotor [ ]  
 Kolbenmaschinen mit 1-3 Zylinder [ ]  
 Kolbenmaschinen mit 2-4 Zylinder [ ]

#### Motorverbindungsart (Elektromotoren):

IEC B5 Flansch [ ]  
 NEMA Flansch [ ]

IEC oder NEMA Flanschcode.....

#### Motorleistung:

-Nominal.....kW

#### Motordrehzahl:

-Normal.....U/min  
 -Maximal.....U/min  
 -Minimal.....U/min

#### Motordrehmoment:

-Normal.....Nm  
 -Maximal.....Nm  
 -Minimal.....Nm

#### Drehrichtung:

in Uhrzeigersinn [ ] gegen Uhrzeigersinn [ ]  
 veränderlich [ ]

#### Betriebsdauer in Stunden pro Tag:

<4 [ ] 4-8 [ ] 8-16 [ ] >16 [ ]

#### Anzahl der Anläufe pro Stunde:

0-50 [ ] 50-100 [ ] 100-200 [ ]  
 200-300 [ ] 300-500 [ ] 500-700 [ ]  
 700-1000 [ ] >1000 [ ]

Übersetzung zwischen Motor und Antriebswelle.....

Erforderliches Anlaufmoment.....Nm

#### Häufigkeit von Lastspitzen pro Stunde:

1-5 [ ] 6-30 [ ] 31-100 [ ] >100 [ ]

#### Einschaltdauer je Stunde (ED):

%100 [ ] %80 [ ] %60 [ ] 40% [ ] %20 [ ]

#### Höhenlage über Meeresspiegel (m):

<1000 [ ] <2000 [ ] <3000 [ ]  
 <4000 [ ] <5000 [ ]

#### Betriebsort:

Kleine geschlossene Räume (w<1m/sn) [ ]  
 Geschlossene Räume (w<3m/sn) [ ]  
 Große Räume und Hallen (w>=3m/sn) [ ]  
 im Freien [ ]

#### Umgebungsbedingungen:

Normal [ ] Staubig [ ] Feucht [ ]  
 Korrodierend [ ] Trocken [ ] Verklebend [ ]

#### Umgebungstemperatur:

Mittelwert.....°C  
 Maximal.....°C  
 Minimal.....°C

#### Rücklauf Sperre erforderlich:

Ja [ ] Nein [ ]

#### Getriebeeingangsvarianten:

R.. [ ] V.. [ ] N.. [ ] T.. [ ]

#### Getriebeausgangsvarianten:

00 [ ] 01 [ ] 02 [ ] 03 [ ] 04 [ ] 05 [ ] 08 [ ]  
 0S [ ] 0E [ ]

#### Montageposition:

M1 [ ] M2 [ ] M3 [ ] M4 [ ] M5 [ ] M6 [ ]

#### Antriebswellenanschluss:

Elastische Kupplung [ ]  
 Trommelkupplung [ ]  
 Hydrokupplung [ ]  
 Starre Flanschkupplung [ ]  
 Riementrieb [ ]  
 Kettenrad [ ]  
 Ritzel [ ]  
 Durchmesser von Anschlusselement.....mm  
 Querkraft.....N  
 "u" Abstand von der Wellenschulter.....mm  
 Axialkraft (in Richtung der Welle +) .....N

#### Abtriebswellenanschluss:

Elastische Kupplung [ ]  
 Trommelkupplung [ ]  
 Starre Flanschkupplung [ ]  
 Riementrieb [ ]  
 Kettenrad [ ]  
 Ritzel [ ]  
 Hohlwelle mit Drehmomentstütze [ ]  
 Schrumpfscheibe mit Drehmomentstütze [ ]  
 Durchmesser von Anschlusselement.....mm  
 Querkraft.....N  
 "u" Abstand von der Wellenschulter.....mm  
 Axialkraft (in Richtung der Welle +) .....N

#### Montage zur Getriebegehäuse mit:

Fuß [ ] Flansch [ ] Drehmomentstütze [ ]

#### Eigenschaften der Abtriebswelle:

Vollwelle mit Passfeder [ ]  
 Vollwelle ohne Passfeder [ ]  
 Hohlwelle mit Schrumpfscheibe [ ]  
 Hohlwelle [ ]  
 Sonderwelle [ ]

#### Eigenschaften der Antriebswelle:

Vollwelle mit Paßfeder [ ]  
 Vollwelle ohne Paßfeder [ ]  
 Sonderwelle [ ]  
 Drehmomentstütze erforderlich Ja [ ] Nein [ ]

#### Spannungsversorgung:

AC-1 phasig [ ] AC-3 phasig [ ] DC [ ]  
 Spannung.....Volt  
 Frequenz.....Hz



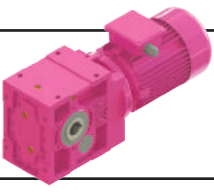

# Genel Bilgiler

## General Information

### Einführung



#### Yağlama

Redüktörlerin uzun ömürlü olması ve iyi performansla çalışabilmesi için, kullanılan yağın seçimi doğru olmalı ve belirtilen zamanlarda değişimleri yapılmalıdır.

Yağın seçiminde devir, çevre sıcaklığı, redüktör yağ sıcaklığı, çalışma koşulları ve yağ ömrü önem taşımaktadır. Redüktörler yağı doldurulmuş olarak sevkedilmektedir. Redüktörler uzun süre depolanacakları zaman veya çalışmaya başlanacağı zaman çalışma konumuna göre üstte kalan tapa sökülmeli ve redüktörün beraberinde verilen havalandırma tapası kullanılmalıdır. Bu redüktörün iç basıncından dolayı oluşacak yağ sızmalarını önleyecektir.

Redüktörlerde standart olarak kullanılan yağlar yan sayfadaki tabloda verilmiştir. Redüktörünüzde kullanılan yağ tipi için lütfen etiketine bakınız. Ayaklı redüktörler ve flanşlı redüktörler M1 pozisyonuna göre yağ ile doldurulmuştur. Bu pozisyonlar dışındaki çalışma durumlarında tablolarda verilen yağ miktarlarına göre ilave veya eksiltme yapılmalıdır. Özel çalışma koşullarında firmamıza danışmanız tavsiye edilir.

Mineral yağlar her 10.000 çalışma saatinde, sentetik yağlar ise her 20.000 çalışma saatinde değiştirilmelidir. Ağır çevre koşullarında (ani ısı değişiklikleri, yüksek nemlilik v.b) yağ değiştirme periyotlarının kısaltılması tavsiye edilir. Mineral yağlar ile sentetik yağlar birbirine kesinlikle karıştırılmamalıdır. Değiştirme işlemi bir çalışma periyodunun hemen peşinden ve yağ sıcakken yapılmalıdır. Bu şekilde bir değiştirme, redüktör içindeki partiküllerin yağa karışmış olarak bulunmasından dolayı iyi bir temizleme ve yağın rahat boşalması neticesini verecektir.

#### Lubrication

*To work in perfect condition and to have long life for the gear box the lubricant must be chosen correctly and changed in time.*

*In selection of oil it is important to consider speed, ambient temperature, gear box oil temperature, working conditions and the life required from the lubricant. All units are filled with lubricant before shipping. Before the gearbox is stored for a long time or before starting up, the top plug (according to the working position) must be removed and the extra given vent plug must be replaced. This prevents excessive pressure which causes oil leakages.*

*The lubricant in the standard line is given for standard fillings on the table on next page. Please look at your gear units label for filled oil type. The foot mounting type gear boxes and where the flange mounted gear boxes are filled for mounting position of M1. For other mounting positions please refer to the table given on the next pages. For special working conditions please contact us.*

*The mineral lubricant should be changed after every 10.000 service hours and the synthetic lubricant should be changed after every 20.000 working hours. If the operation conditions are very heavy (e.g. high temperature differences, high humidity) shorter intervals between changes are recommended. Mineral and synthetic oils must not be mixed up. By changing the lubricant complete cleaning is advised. The oil change should be done after a working period. Because oil is hot in this condition and impurities are mixed with it the changing of oil will be done in best result and the oil will drain easily.*

#### Schmierung

Um eine lange Lebensdauer zu gewährleisten muss der Schmierstoff richtig ausgewählt werden.

Für die richtige Ölauswahl müssen Drehzahl, Umgebungstemperatur, Belastungsart und Lebensdauer des Öls berücksichtigt werden. Die mitgelieferte Entlüftungsschraube ist vor Inbetriebnahme oder längeren Lagern gegen die Einfüllschraube auszutauschen, um einen Überdruck im Getriebe und damit eine Undichtigkeit des Getriebes zu vermeiden. Getriebe und Getriebemotoren sind bei Auslieferung betriebsfertig gefüllt.

Ohne besondere Bestellangaben werden die Getriebe grundsätzlich mit den auf der folgenden Seite in der grau unterlegten Spalte angegebenen Schmierstoffen gefüllt. Bitte im Getriebe verwendetes Öl von dem Namensschild ablesen. Die fußbefestigten Getriebe sind befüllt für Bauform und die flanschbefestigten Getriebe für Bauform M1. Für andere Bauformen sind die auf der nächsten Seite angegebenen Füllmengen zu beachten.

Ein Schmierstoffwechsel sollte alle 10.000 Betriebsstunden durchgeführt werden. Für synthetische Produkte verdoppeln sich diese Fristen. Bei extremen Betriebsbedingungen, z.B. hohe Luftfeuchtigkeit, aggressiver Umgebung und hohen Temperaturschwankungen sind kürzere Schmierstoffintervalle vorteilhaft. Es ist empfehlenswert, dem Schmierstoffwechsel mit einer gründlichen Reinigung des Getriebes zu verbinden. Synthetische und mineralische Schmierstoffe dürfen nicht miteinander vermischt werden. Das Ablassen des Öls soll unmittelbar nach dem Stillsetzen erfolgen, solange das Öl noch warm ist. In diesem Zustand ist das Öl mit den Schmutzpartikeln vermisch, so dass eine Entfernung des Altsöls eine gute Reinigung garantiert.

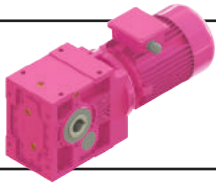

# Genel Bilgiler

## General Information

## Einführung



### Yağ Tipleri / Oil Types / Schmierstoffe

Yağ Cinsi Lubricant Art des Schmierers	DIN 51517-3	Çevre Sıcaklığı [°C] Ambient Temp. [°C] Umgebungstemp. [°C]	ISO VG	Aral	Beyond Petroleum	Castrol	Klüber Lubrication	Mobil	Shell	Total
		Daldırma Yağlama Dip Lubrication Tauchschmier.								
Mineral Yağlar Mineral Oil Mineralöl	CLP	0 ... +50	680	Degol BG 680	Energol GR-XP 680	Alpha SP 680	Klüberoil GEM 1-680 N	Mobilgear XMP 680	Omala 680	Carter EP 680
		-5 ... +45	460	Degol BG 460	Energol GR-XP 460	Alpha SP 460	Klüberoil GEM 1-460 N	Mobilgear XMP 460	Omala F460	Carter EP 460
		-10 ... +40	320	Degol BG 320	Energol GR-XP 320	Alpha SP 320	Klüberoil GEM 1-320 N	Mobilgear XMP 320	Omala F320	Carter EP 320
		-15 ... +30	220	Degol BG 220	Energol GR-XP 220	Alpha SP 220	Klüberoil GEM 1-220 N	Mobilgear XMP 220	Omala F220	Carter EP 220
		-20 ... +20	150	Degol BG 150	Energol GR-XP 150	Alpha SP 150	Klüberoil GEM 1-150 N	Mobilgear XMP 150	Omala 150	Carter EP 150
		-25... +10	100	Degol BG 100	Energol GR-XP 100	Alpha SP 100	Klüberoil GEM 1-100 N	-	Omala 100	Carter EP 100
Sentetik Yağlar Synthetic Oil Synthetisches Öl	CLP PG	-10 ... +60	680	Degol GS 680	Energol SG-XP 680	-	Klübersynth GH 6 -680	Mobil Glygoyle 680	Tivela S 680	Carter SY 680
		-20 ... +50	460	Degol GS 460	Energol SG-XP 460	Aphasyn PG 460	Klübersynth GH 6 -460	Mobil Glygoyle 460	Tivela S 460	Carter SY 460
		-25 ... +40	320	Degol GS 320	Energol SG-XP 320	Aphasyn PG 320	Klübersynth GH 6 -320	Mobil Glygoyle 320	Tivela S 320	Carter SY 320
		-30 ... +30	220	Degol GS 220	Energol SG-XP 220	Aphasyn PG 220	Klübersynth GH 6 -220	-	Tivela S 220	Carter SY 220
		-35 ... +20	150	Degol GS 150	Energol SG-XP 150	Aphasyn PG 150	Klübersynth GH 6 -150	-	Tivela S 150	Carter SY 150
		-40 ... +10	100	-	-	-	Klübersynth GH 6 -100	-	-	-
	CLP HC	-10 ... +60	680	-	-	-	Klübersynth GEM 4-680 N	Mobilgear SHC XMP 680	-	Carter SH 680
		-20 ... +50	460	Degol PAS 460	Energol EP-XF 460	Alphasyn T 460	Klübersynth GEM 4-460 N	Mobilgear SHC XMP 460	Omala HD 460	Carter SH 460
		-25 ... +40	320	Degol PAS 320	Energol EP-XF 320	Alphasyn T 320	Klübersynth GEM 4-320 N	Mobilgear SHC XMP 320	Omala HD 320	Carter SH 320
		-30 ... +30	220	Degol PAS 220	Energol EP-XF 220	Alphasyn T 220	Klübersynth GEM 4-220 N	Mobilgear SHC XMP 220	Omala HD 220	Carter SH 220
		-35 ... +20	150	Degol PAS 150	Energol EP-XF 150	Alphasyn T 150	Klübersynth GEM 4-150 N	Mobilgear SHC XMP 150	Omala HD 150	Carter SH 150
		-40 ... +10	100	-	-	-	Klübersynth GEM 4-100 N	-	-	-
Gıda Uyumlu Yağ Food Grade Oil Lebensmittelöl	CLP NSF H1	-15 ... +25	320	-	-	Optileb GT 320	Klüberoil 4 UH1-320 N	Mobil SHC Cibus 320	Cassida Fluid GL-320	Nevastane SL 320
Çevre Dostu Yağ Biodegradable Oil Biologisch abbaubares Öl	CLP E	-25 ... +40	320	-	-	Tribol BioTop 1418-320	Klübersynth GEM 2-320	-	-	Carter Bio 320
Mineral Gresler [ -20 .... +120 Çalışma Sıcaklığı °C] Mineral Grease [ -20 ..... +120 Working Temperature °C] Mineral-Fett [ -20 ..... +120 Betriebstemperatur °C]				Aralub HL3	Energol LS 3	Speerol AP3	Centoplex 2 EP	Mobilux EP 3	Alvania RL3	Multis Complex EP 2
Sentetik Gresler [ -30 .... +100 Çalışma Sıcaklığı °C] Synthetic Grease [ -30 ..... +100 Working Temperature °C] Synthetisches Fett [ -30 ..... +100 Betriebstemperatur °C]				-	Energol SY 2202	-	Petamo GHY 133 N	Mobiltemp SHC 100	Cassida RLS 2	Multis Complex SHD 220

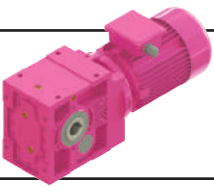

# Genel Bilgiler

## General Information

### Einführung



Montaj Pozisyonları / Mounting Positions / Bauformen

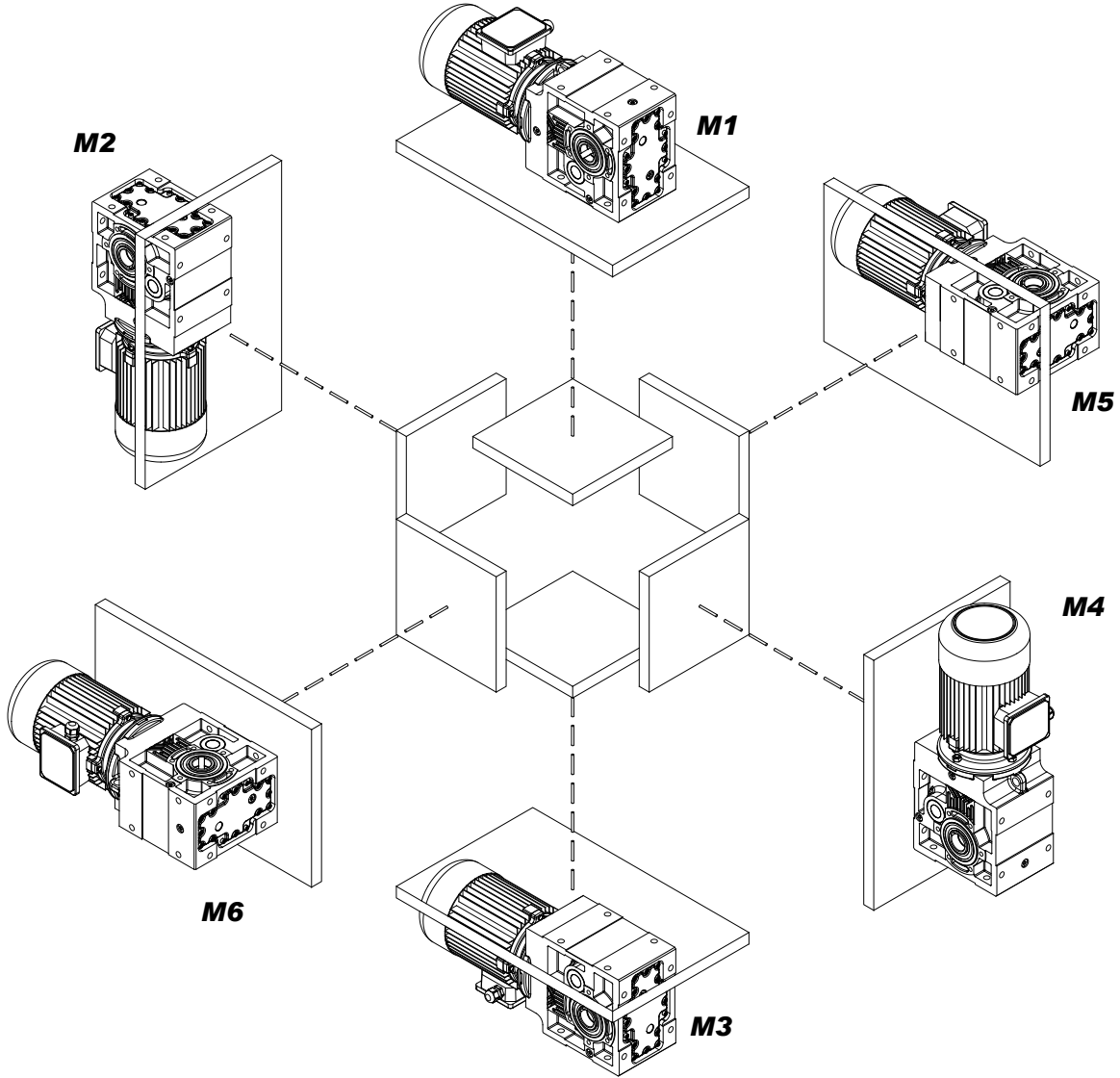

**M1....M6 'ya kadar belirtilen montaj pozisyonları redüktörün duruş yönü referans alınarak belirlenmiştir. Montaj yüzeyleri bağlayıcı değildir.**  
*Figured mounting positions of M1 to M6 are determined as reference of directional position of the gearbox. Mounting surfaces are not binding.*  
Dargestellte Montagepositionen M1 bis M6 wurden nach der Stehrichtung von Getriebe bestimmt. Montageoberflächen sind unverbindlich.

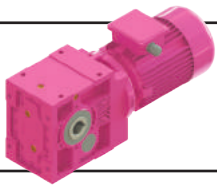

# Genel Bilgiler

## General Information

### Einführung



#### K.00. - K.20. İki - Üç Kademeli Helisel-Konik Dişli Redüktörler Yağ Seviye Tapaları

K.00. - K.20. Two - Three Stage Helical-Bevel Geared Gearboxes Oil Level Plugs

K.00. - K.20. Zwei-Dreistufige Stirn-Kegelradgetriebe Ölverschlußschrauben

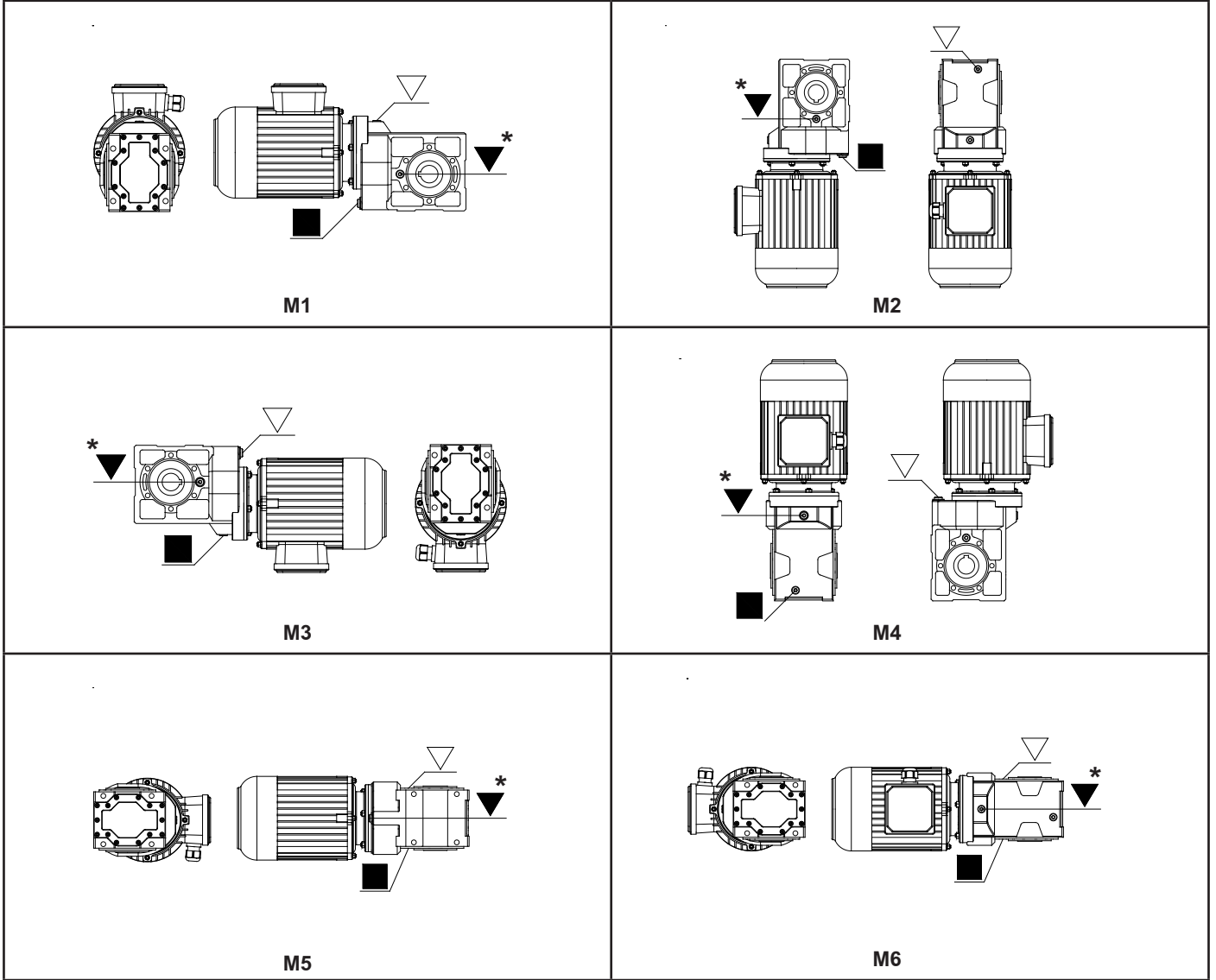

\* : K002 ve K003'de bu tapa yoktur. Lütfen yağ miktarına göre yağ koyunuz.

\* : For K002 and K003 this plug doesn't exist. Please refer to oil quantities.

\* : Bei K002 und K003 existiert dieser Ölstandschaube nicht. Bitte nach Ölmenge füllen.

#### Yağ Miktarları (lt) / Oil Quantities (lt) / Ölmengen (liter)

Tip / Type / Typ	M1	M2	M3	M4	M5	M6
K.00.	0.3	0,45	0,5	0.6	0.4	0.35
K.10.	0.6	0.8	0.7	0.8	0.7	0.7
K.20.	1.0	1.5	1.6	1.7	1.2	1.1

Semboller : : Yağ boşaltma

Symbols : ■ : Drain plug

Symbole : : Ölauslass

▽ : Yağ doldurma ve havalandırma

▽ : Oil Filling and Vent plug

: Öfüllung und Entlüftung

▼ : Yağ seviyesi

▼ : Oil level

: Ölstand

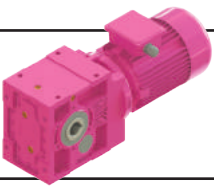

# Genel Bilgiler

## General Information

### Einführung



#### K.273 - K.873 Üç Kademeli Helisel-Konik Dişli Redüktörler Yağ Seviye Tapaları

K.273 - K.873 Three Stage Helical-Bevel Geared Gearboxes Oil Level Plugs

K.273 - K.873 Dreistufig Stirn-Kegelradgetriebe Ölverschlußschrauben

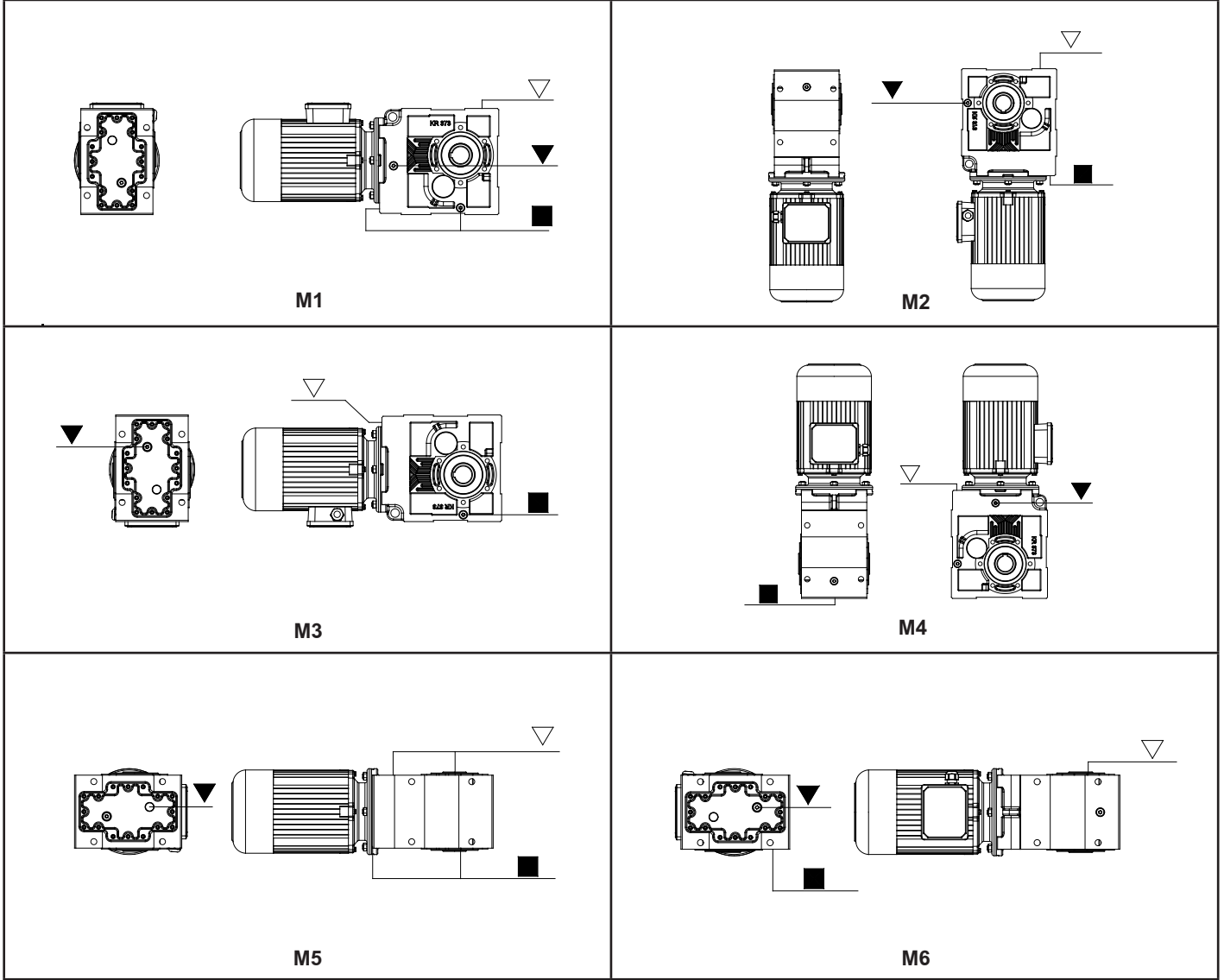

Yağ Miktarları (lt) / Oil Quantities (lt) / Ölmenge (liter)

Tip / Type / Typ	M1	M2	M3	M4	M5	M6
K.273	1,3	2,0	2,0	2,1	1,5	1,3
K.373	2,1	3,3	3,2	3,7	2,4	2,8
K.473	5,0	6,5	6,0	7,0	4,8	5,5
K.573	6,5	9,5	9,5	10,0	7,5	8,0
K.673	15,0	19,0	19,0	20,5	18,0	17,0
K.773	21,0	31,0	29,0	34,0	25,0	21,0
K.873	37,0	50,0	50,0	60,0	45,0	39,0

Semboller : : Yağ boşaltma  
Symbols : ■ : Drain plug  
Symbole : : Ölauslass

▽ : Yağ doldurma ve havalandırma  
▽ : Oil Filling and Vent plug  
▽ : Ölfüllung und Entlüftung

▽ : Yağ seviyesi  
▽ : Oil level  
▽ : Ölstand

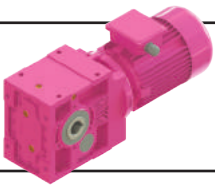

# Genel Bilgiler

## General Information

### Einführung



**K.374 - K.874 Dört Kademeli Helisel-Konik Dişli Redüktörler Yağ Seviye Tapaları**  
**K.374 - K.874 Four Stage Reduction Helical-Bevel Geared Gearboxes Oil Level Plugs**  
**K.374 - K.874 Vierstufig Stirn-Kegelradgetriebe Ölverschlußschrauben**

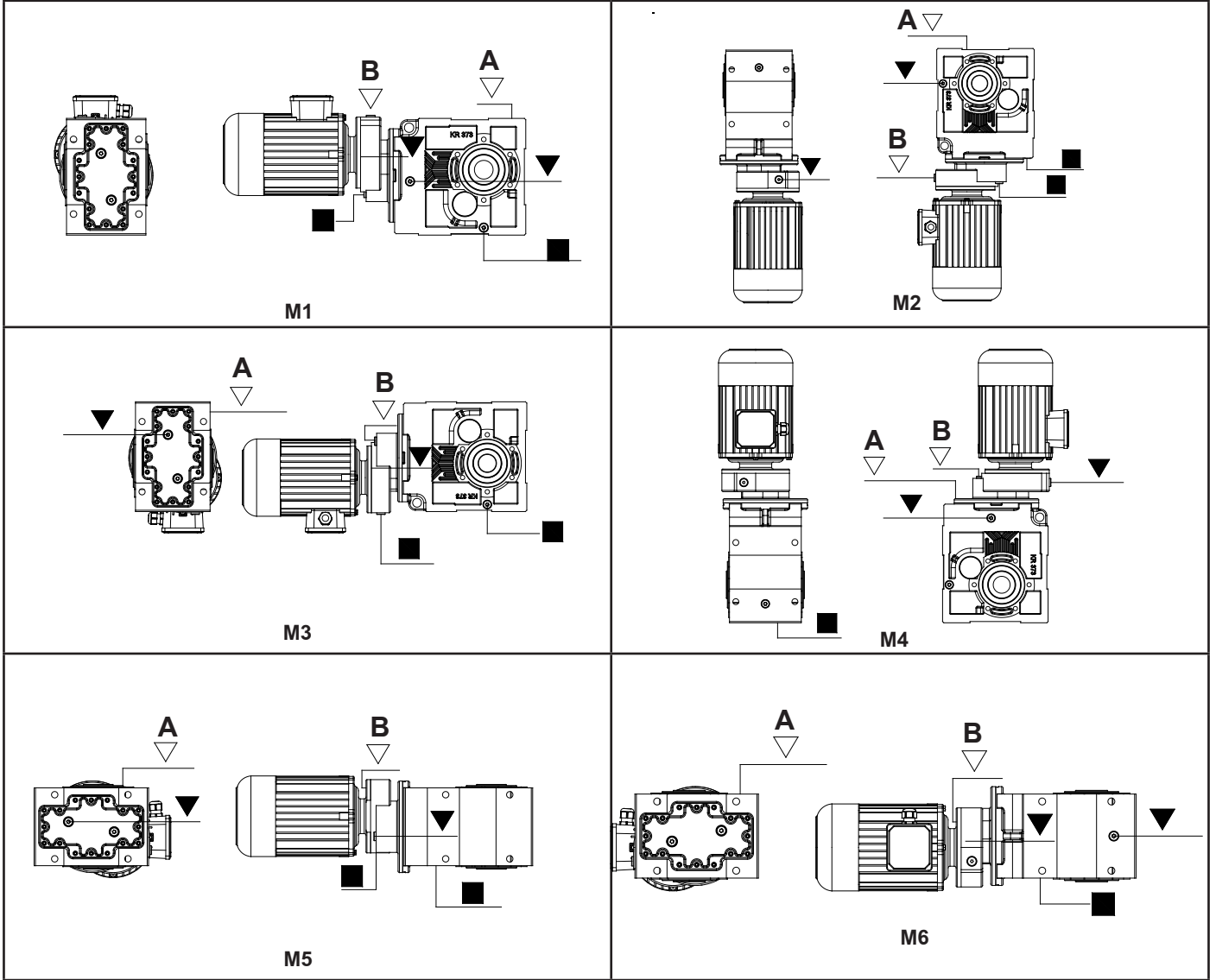

**Yağ Miktarları (lt) / Oil Quantities (lt) / Ölmenge (liter)**

Tip / Type / Typ	M1 A / B	M2 A / B	M3 A / B	M4 A / B	M5 A / B	M6 A / B
<b>K.374</b>	2,1 / 0,25	3,3 / 0,7	3,2 / 0,25	3,7 / 0,25	2,4 / 0,25	2,8 / 0,25
<b>K.474</b>	5,0 / 0,4	6,5 / 1,5	6,0 / 0,4	7,0 / 0,4	4,8 / 0,4	5,5 / 0,4
<b>K.574</b>	6,5 / 0,5	9,5 / 1,5	9,5 / 0,5	10,0 / 0,5	7,5 / 0,5	8,0 / 0,5
<b>K.674</b>	15,0 / 0,9	19,0 / 4,0	19,0 / 0,9	20,5 / 0,9	18,0 / 0,9	17,0 / 1,0
<b>K.774</b>	21,0 / 1,0	29,0 / 4,0	29,0 / 1,0	34,0 / 1,0	25,0 / 1,0	21,0 / 1,0
<b>K.874</b>	37,0 / 2,15	50,0 / 4,0	50,0 / 2,15	60,0 / 2,15	45,0 / 2,15	39,0 / 2,15

**Semboller :** : Yağ boşaltma  
**Symbols :** ■ : Drain plug  
**Symbole :** : Ölauslass

**▽ :** Yağ doldurma ve havalandırma  
**▽ :** Oil Filling and Vent plug  
**▽ :** Öfüllung und Entlüftung

**▼ :** Yağ seviyesi  
**▼ :** Oil level  
**▼ :** Ölstand

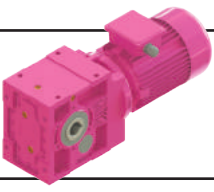

# Genel Bilgiler

## General Information

### Einführung



**K.27. - K.87. Beş-Altı Kademeli Helisel-Konik Dişli Redüktörler Yağ Seviye Tapaları**  
K.27. - K.87. Five-Six Stage Helical-Bevel Geared Gearboxes Oil Level Plugs  
K.27. - K.87. Fünf-Sechsstufig Stirn-Kegelradgetriebe Ölverschlußschrauben

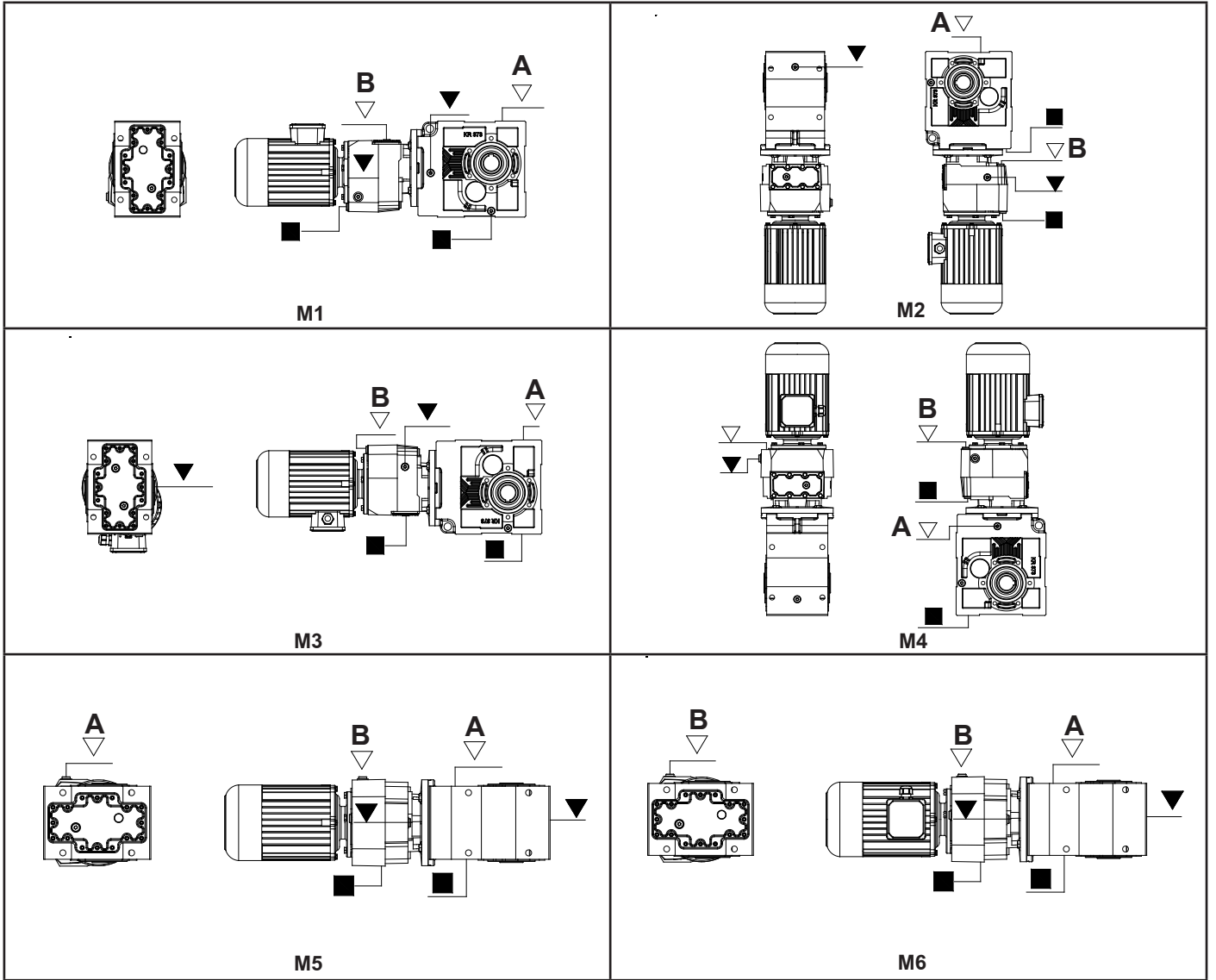

**Yağ Miktarları (lt.) / Oil Quantities. (lt) / Ölmengen (liter)**

Tip / Type / Typ	M1 A / B	M2 A / B	M3 A / B	M4 A / B	M5 A / B	M6 A / B
K.275-276	1,3 / 0,4	2,0/0,4	2,0 / 0,4	2,1 / 0,4	1,3 / 0,4	1,5 / 0,4
K.375-376	2,10 / 0,7	3,3 / 0,85	3,2 / 0,7	3,7 / 0,7	2,8 / 0,7	2,4 / 0,7
K.475-476	5 / 1,2	6,5 / 1,9	6,0 / 1,2	7,0 / 1,2	5,5 / 1,2	4,8 / 1,2
K.575-576	6,5 / 1,2	9,5 / 1,75	9,5 / 1,2	10,0 / 1,2	8,0 / 1,2	7,5 / 1,2
K.675-676	15,0 / 2,0	19,0 / 3,1	19,0 / 2,0	20,5 / 2,0	17,0 / 2,0	18,0 / 2,0
K.775-776	21 / 2,0	31,0 / 3,1	29,0 / 2,0	34,0 / 2,0	21,0 / 2,0	25,0 / 2,0
K.875-876	37,0 / 2,0	50,0 / 3,1	50,0 / 2,0	60,0 / 2,0	39,0 / 2,0	45,0 / 2,0

**Semboller :** ■ : Yağ boşaltma  
**Symbols :** ■ : Drain plug  
**Symbole :** ■ : Ölauslass

▽ : Yağ doldurma ve havalandırma  
▽ : Oil Filling and Vent plug  
▽ : Öfüllung und Entlüftung

▼ : Yağ seviyesi  
▼ : Oil level  
▼ : Ölstand

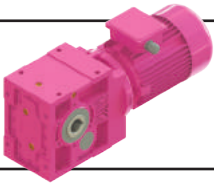

# Genel Bilgiler

## General Information

### Einführung



#### MOTORLAR

##### AC Motorlar

##### a- Genel Özellikler:

Basit konstrüksiyonlu, bakım gerektirmez, güvenilirliği yüksek ve uygun fiyatlı olmaları nedeni ile trifaze asenkron motorlar en çok kullanılan motor cinsidir. Bu motorların çalışma karakteristikleri moment-hız eğrisi ile belirlenir. Aşağıda bu karakteristik eğrisine bir örnek verilmiştir.

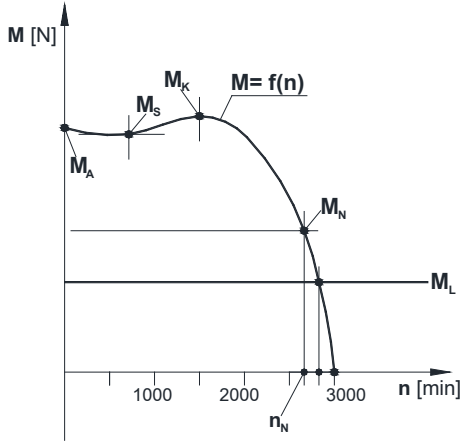

Motorun her start yapılmasında bu eğriye uygun hareket eder ve yük momenti  $M_L$  ile bu eğrinin çakıştığı nokta, motorun çalışma anındaki moment ve devirini verir.

Statorun manyetik alanı senkron hızla  $n_s$  döner. Kutuplar arasındaki faz kayması 3 fazlı motorlarda  $120^\circ$  'dir.

$$n_s = 120 \times \frac{f}{p_s}$$

$f$ .....: şebeke frekansı [Hz]  
 $p_s$ .....: statorun kutup sayısı

Rotorun değişken manyetik alanı rotorun statorun manyetik alanının dönüşü yönünde dönmeye başlamasını sağlar. Rotor bu hareketinde statorun manyetik alanını takip eder ama hiçbir zaman yakalayamaz. Rotor statorun manyetik alanının hızından yavaş döner. Rotorun bu hızına baz hız  $n_N$  denir. Yükün azalması rotorun hızının artmasını sağlar, aynı zamanda sapma azalır. Sapma aşağıdaki gibi belirlenmiştir:

$$s = \frac{n_s - n_N}{n_s} \times 100$$

Sapmanın miktarına göre motorun nominal değerlerinde şu farklılıklar olabilir.

Sapma  $s$  .....:  $\pm 20\%$   
Kalkış Akımı.....:  $\pm 20\%$   
Kalkış Momenti.....:  $-15/+25\%$   
Kütle Atalet Momenti.....:  $\pm 10\%$   
Verim (37 kW'a kadar).....:  $-0,15 (1-\eta)$

#### MOTORS

##### AC Motors

##### a- General Specifications:

On account of its simple and maintenance free construction, good reliability and price, the three phase squirrel cage motor is one of the most frequently employed electric motors. The run up behavior of a three phase squirrel cage motor is described by the torque-speed characteristic curve. An example is shown below.

$M_A$ : Start momenti / Starting torque / Anlaufmoment

$M_S$ : Demeraj momenti / Pull-up torque / Anziehungsmoment

$M_K$ : Frenleme momenti / Pull-out torque / Bremsmoment

$M_N$ : Motorun ilettiği moment / Motor rated torque / Treibmoment

$M_L$ : Yük momenti / Load torque / Lastmoment

The motor follows this torque characteristics up to its stable operating point every time, when it is switched on. Operating point is that point, where the moment speed curve intersects with load torque  $M_L$  line.

The magnetic field in the stator rotates at a synchronous speed  $n_s$ . Phase shift of each pole is  $120^\circ$  at 3 phase motors.

$$n_s = 120 \times \frac{f}{p_s}$$

$f$ .....: supply frequency [Hz]  
 $p_s$ .....: number of stator poles

Because of the alternating magnetic field in the rotor, the rotor starts running in the same direction of the stator flux and tries to catch up with the rotating flux. The rotor never catches up the stator field. The rotor runs slower than the speed of the stator field. This speed is called the base speed  $n_N$ .

A decrease in load will cause the rotor to speed up or decrease slip. The slip is defined as follows:

$$s = \frac{n_s - n_N}{n_s} \times 100$$

According to the slip, the nominal values of the electric motor can alter as follows:

Slip  $s$  .....:  $\pm 20\%$   
Starting current .....:  $\pm 20\%$   
Starting torque .....:  $-15/+25\%$   
Moment of inertia.....:  $\pm 10\%$   
Efficiency (up to 37 kW).....:  $-0,15 (1-\eta)$

#### MOTOREN

##### Drehstrommotoren:

##### a- Allgemeine Eigenschaften

Wegen die wartungsarme und leichte Konstruktion, hohe Sicherheit bei Nutzung und günstige Preise werden die asynchrone Drehstrommotoren am meisten benutzt. Motoranlaufverhalten wird mit Moment-Drehzahl-Kurve charakterisiert. Ein Beispiel ist unten angegeben.

Der Drehstrommotor läuft diese Kurve bei jeder Anlauf, bis dem stabilen Betriebspunkt erreicht wird. Betriebspunkt ist der Zustand, bei dem die Moment-Drehzahl-Kurve sich mit der Linie von erforderlichen Moment  $M_L$  schneidet.

Magnetisches Feld von Stator dreht sich mit synchroner Geschwindigkeit  $n_s$ . Phasenverschiebung von den Polen ist  $120^\circ$  bei 3phasigen Drehstrommotoren.

$$n_s = 120 \times \frac{f}{p_s}$$

$f$ .....: Frequenz der Spannung [Hz]  
 $p_s$ .....: Anzahl der Polen von Stator

Durch das magnetische Wechselfeld in den Rotor, beginnt der Rotor sich in der gleichen Richtung des Statorflusses zu drehen und versucht diese Bewegung aufzuholen. Der Rotor kann den Statorfeld nie aufholen. Die Rotorgeschwindigkeit nennt man Basisgeschwindigkeit  $n_N$ . Eine Abnahme der Belastung bewirkt, dass der Rotor sich beschleunigt und der Schlupf sich verringert. Der Schlupf wird wie folgt definiert:

$$s = \frac{n_s - n_N}{n_s} \times 100$$

Für die nominale Werte der Drehstrommotoren sind folgende Abweichungen zulässig:

Schlupf  $s$  .....:  $\pm 20\%$   
Anzugsstrom .....:  $\pm 20\%$   
Anzugsmoment .....:  $-15/+25\%$   
Massentägheitsmoment .....:  $\pm 10\%$   
Wirkungsgrad (bis 37 kW).....:  $-0,15 (1-\eta)$

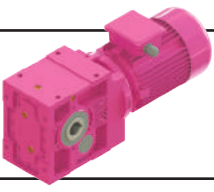

# Genel Bilgiler

## General Information

### Einführung



#### b- Çalışma Türleri

Katalogta verilen tüm redüktörlerin motorları S1 çalışma türüne uygun verilmektedir. Diğer çalışma türleri aşağıdaki tabloda gösterilmiştir.

#### b-Modes of Operation

All motors of the catalogue have been laid out for duty S1 (continuous operation). Other duty types are given on the following table.

#### b-Betriebsarten

Die im Katalog angeführten Motoren sind für Betriebsart S1 (Dauerbetrieb) ausgelegt. Andere Betriebsarten sind unten angegeben.

Çalışma Türü Operation Betriebsarten	Açıklama Explanation Erläuterung	Yük Grafiği Load Graphic Lastverläufe
S1	<b>Sabit yükte sürekli çalışma</b> Continuous operation under constant load Dauerbetrieb mit konstanter Belastung	
S2	<b>Sabit yükte kısa süreli çalışma</b> Short-time duty under constant load Kurzbetrieb mit konstanter Belastung	
S3	<b>Yolvermede sıcaklık artımı olmadan periyodik çalışma</b> Periodic duty without influence of start-up on temperature Aussetzbetrieb ohne Einfluß des Anlaufens auf die Temperatur	
S4	<b>Yolvermede sıcaklık artımı olan periyodik çalışma</b> Periodic duty with influence of start up on temperature Aussetzbetrieb mit Einfluß des Anlaufens auf die Temperatur	
S5	<b>Yolvermede ve frenlemede sıcaklık artımlı periyodik çalışma</b> Periodic duty with influence of startup and braking on temp. Aussetzbetrieb mit Einfluß des Anlaufens / Bremsung auf die Temp.	
S6	<b>Sürekli orta darbeleri çalışma</b> Continuous operation with intermittent loading Durchlaufbetrieb mit Aussetzungsbelastung	
S7	<b>Elektriksel frenlemeli sürekli orta darbeleri çalışma</b> Continuous operation with intermittent loading and braking Ununterbrochener Betrieb mit Anlauf und Bremsung	
S8	<b>Devir ve yük değişimli sürekli çalışma</b> Continuous operation duty type with related load-speed changes Ununterbrochener periodischer Betrieb mit Drehzahländerung	

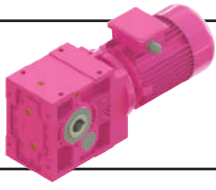

# Genel Bilgiler

## General Information

### Einführung



#### c- Koruma Sınıfı:

Yılmaz Redüktörde standart olarak IP54 (IEC 34-5) koruma sınıfı motorlar kullanılmaktadır. Diğer koruma sınıfları istendiğinde firmamıza danışınız.

#### d- İzolasyon Sınıfı:

Yılmaz Redüktörde kullanılan standart izolasyon sınıfı F (IEC 317-8) dir. İstek üzerine H sınıfı yapılabilmektedir.

#### e- Verim Sınıfları:

Üç fazlı az gerilim asenkron motorların verim sınıfı ölçümü IEC 60034-2-1:2007 normu ile belirlenmiştir. Yeni IE verim sınıfı 0,75 kW'tan 375 kW'a kadar güç aralığında çalışan AC motorlar için geçerlidir. EFF verim sınıfından farklı olarak IE verim sınıfı 6 kutup sayılı motorlar içinde kullanılabilir. Aşağıda verim sınıfları sıralanmıştır. Bölgeler dışında verim sınıfı zorunlulukları ülkelere göre farklılık gösterebilir. Lütfen firmamıza danışınız. Başka ürünlere entegre olmuş ve bu nedenle motorun veriminin bağımsız belirlenmediği sistemlerde (redüktör pompa gibi) verim sınıflandırması geçerli değildir.

#### c- Protection Class:

Yılmaz Redüktör uses IP54 (IEC 34-5) protection class electric motors for standard products. If different kind of protection class is requested please contact us.

#### d- Insulation Class:

Yılmaz Redüktör uses F (IEC 317-8) insulation class electric motors for standard products. H insulation class is available upon request.

#### e- Efficiency Classes:

The method for measuring the efficiency of low voltage three-phase asynchronous motors was revised with the new IEC 60034-2-1:2007 standard. The new IE classes is valid for AC Motors in power range from 0,75 to 375 kW. Unlike the EFF classes IE classes can be used for 6-pole AC motors. Bellow is the table of efficiency classes. The instructions for efficiency classes can differ from country to country. Please contact with us for more information. For the motors, which are fully integrated into a product (for example gear, pump) so their energy efficiency can not be recognized independently, the requirements of efficiency are not valid in Europe.

#### c- Schutzarten:

Yılmaz Redüktör Getriebemotoren werden serienmäßig mit Schutzart IP54 (IEC34-5) ausgeführt. Für andere Schutzarten bitte rückfragen.

#### d- Isolationsklasse:

Yılmaz Redüktör Getriebemotoren werden serienmäßig in Wärmeklasse F (IEC317-8) ausgeführt. H Wärmeklasse ist möglich auf Kundenwunsch.

#### e- Energieeffizienzklassen:

Die Methode für Messung die Effizienz von drei phasigen gering Spannung Asynchronmotoren hat neu mit IEC 60034-2-1:2007 Norm festgelegt. Die neue IE-Klassen gelten für alle Drehstrommotoren im Leistungsbereich von 0,75 bis 375 kW. Anders als EFF-Klassen die IE-Klassen können auch für 6-polige Drehstrommotoren verwendet werden. Unten steht die Tabelle der Effizienzklassen. Die Richtlinien für Effizienzklassen können sich je nach dem Land unterscheiden. Bitte mit unserem Firma Kontakt aufnehmen. Für die Motoren, die vollständig in ein Produkt (zum Beispiel Getriebe, Pumpe) eingebaut sind und deren Energieeffizienz nicht unabhängig von diesem Produkt erfasst werden kann, gelten in Europa die Anforderungen der Effizienzklassen nicht.

Verim Sınıfları Efficiency Classes Energieeffizienzklassen			4 Kutuplu Motor Verim Değeri Hesabı Calculating Efficiency Values of Motors with 4 Poles Berechnung der Wirkungsgrade von Elektromotoren mit 4 Polen	
IE1	EFF 2	<b>Standart Verim</b> Standart Efficiency Standarte Energieeffizienz	A=0,5234 B=-5,0499 C=17,4180 D=74,3171	$\eta_{Mn} = A \times [\log_{10}(P_L)] + B \times [\log_{10}(P_L)]^2 + C \times \log_{10}(P_L) + D$ <p><math>P_L</math> :Anma Yüğü [kW] / Nominal Load [kW] / Nennlast [kW]</p> <p><math>\eta_{Mn}</math> :Nominal verim / Nominal Efficiency [kW] / Sollwirkungsgrad</p>
IE2	EFF 1	<b>Yüksek Verim</b> High Efficiency Hohe Energieeffizienz	A=0,0278 B=-1,9247 C=10,4395 D=80,9761	
IE3	-	<b>Premium Verim</b> Premium Efficiency Premium Energieeffizienz	A=0,0773 B=-1,8951 C=9,2984 D=83,7025	
IE4	-	<b>Süper Premium Verim</b> Super Premium Efficiency Super Premium Energieeffizienz	-	

4 Kutuplu Motor Verim Değeri Efficiency Values of Motor with 4 poles Sollwirkungsgrad des Motors mit 4 Polen	Anma Yüğü [kW] Nominal Load [kW] Nennlast [kW]	Verim Sınıfı / Efficiency Class / Energieeffizienzklassen		
		IE1	IE2	IE3
	0,75	72,1 %	79,6 %	82,5 %
	1,5	77,2 %	82,8 %	85,3 %
	3	81,5 %	85,5 %	87,7 %
	7,5	86 %	88,7 %	90,4 %
	15	88,7 %	90,6 %	92,1 %
	22	89,9 %	91,6 %	93 %
	37	91,2 %	92,7 %	93,9 %
	45	91,7 %	93,1 %	94,2 %
	75	92,7 %	94 %	95 %
	90	93 %	94,2 %	95,2 %
	330	94 %	95,1 %	96 %

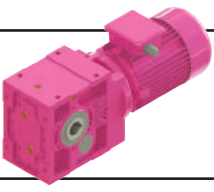

# Genel Bilgiler General Information Einführung



## f- AC Frekans Invertörler

Doğru Akımı (DC), alternatif akıma (AC) çeviren elektronik çeviricilere invertör denilmektedir. AC motorlar için elektronik hız kontrol cihazları genellikle AC giriş akımını doğrultucu diyotlarla DC akıma çevirir ve daha sonra çevirici diyotlar vasıtasıyla bu akımı tekrar AC akıma çevirir. Doğrultucu diyotlar ile çevirici diyotlar arasındaki bağlantı DC-bağ olarak tanımlanmaktadır. DC kontrol cihazının (genellikle invertör olarak isimlendirilir) elektriksel blok şeması aşağıda verilmiştir.

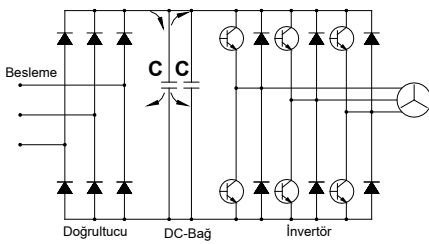

Tam dalga doğrultucuları besleyen üç faz besleme akımı DC-bağ kapasitörlerine iletilir. Kapasitörler voltajdaki dalgalanmaları azaltır ve kısa süreli ağıdaki akım kesintilerinde enerji sağlar. Kapasitörlerdeki voltaj kontrolsüzdür ve gelen AC akımın pik akım değerlerine bağlıdır. DC akım tekrar AC akıma, Puls genişliği modülasyonu (PWM) kullanılarak çevrilir. İstenen dalga formu, sabit bir frekansta (Puls frekansında), çıkış transistörlerinin (İzole edilmiş geçit Bipolar transistörleri; IGBT'ler) açılıp kapatılması ile oluşturulur. IGBT'lerin açma kapama zamanlarının değişimi ile istenen akım oluşturulabilir. Çıkış voltajı bir seri kare dalga pulslardır ve motor sargılarının indüktansı ile sinusoidal bir motor akımı oluşur. Puls genişliği modülasyonu aşağıda gösterilmiştir.

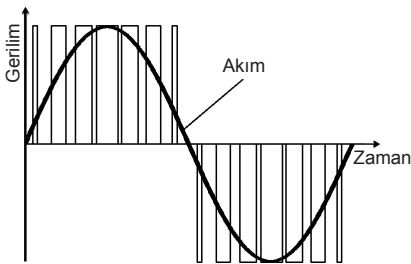

## f- AC Frequency Inverters

An electronic converter is a device which converts Direct Current (DC) to Alternating Current (AC) is known as an inverter. Electronic speed controllers for AC motors usually convert the AC supply to DC using a rectifier, and then convert it back to a variable frequency, variable voltage AC supply using an inverter bridge. The connection between the rectifier and inverter is called the DC link. The block diagram of a speed controller (often called an inverter) is shown below.

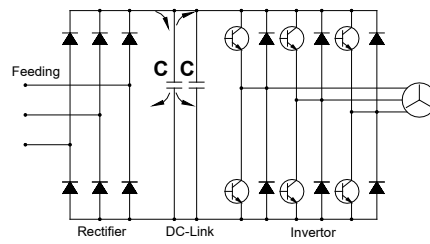

The three phase supply is fed into a full wave rectifier which supplies the DC link capacitors. The capacitors reduce the voltage ripple (especially on single supplies) and supply energy for short mains breaks. The voltage on the capacitors is uncontrolled and depends on the peak AC supply voltage. The DC voltage is converted back to AC using Pulse Width Modulation (PWM). The desired waveform is built up by switching the output transistors (Insulated Gate Bipolar Transistors; IGBTs) on and off at a fixed frequency (the switching frequency). By varying the on and off time of the IGBTs the desired current can be generated. The output voltage is still a series of square wave pulses and the inductance of the motor windings results in a sinusoidal motor current. Pulse Width Modulation is shown in the figure below.

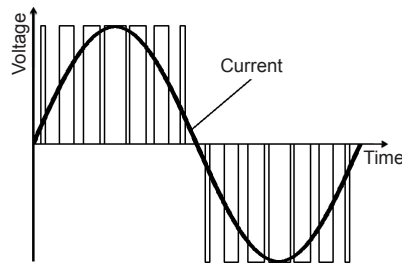

## f- AC Frequenz Umrichter

Ein elektronischer Wandler, der den Gleichstrom (DC) in Wechselstrom (AC) umwandelt, wird als Umrichter bezeichnet. Ein Frequenzumrichter benutzt einen ungesteuerten Eingangsgleichrichter, um die Netzspannung in Gleichspannung umzuwandeln. Diese wird dann in den Zwischenkreiskondensatoren gespeichert. An diesem Gleichspannungszwischenkreis ist ein Wechselrichter angeschlossen. Dieser Wechselrichter erzeugt am Ausgang eine variable Frequenz und eine variable Spannung. Der Anschluss zwischen dem Gleichrichter und dem Wechselrichter nennt man Gleichstromverbindung. Das Blockschaltbild von diesem System wurde unten dargestellt:

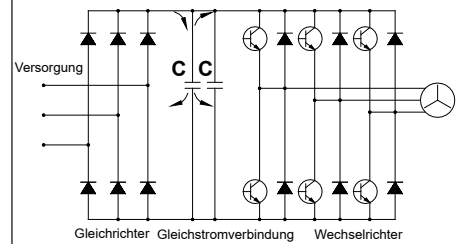

Auch bei dreiphasiger Versorgung wird die gleichrichtete Netzspannung den Zwischenkreiskondensatoren zugeführt. Die Kondensatoren reduzieren die Oberwelligkeit der Spannung (was besonders bei einphasiger Versorgung entscheidend ist) und liefern Energie, die kurze Unterbrechungen der Netzstromversorgung ermöglicht. Die Spannung der Kondensatoren ist vom Spitzenwert der Wechselspannung abhängig. Die Gleichspannung wird im Wechselrichter durch Pulsweitenmodulation (PWM) in Wechselspannung umgewandelt. Die gewünschte Wellenform wird durch Ein- und Ausschalten der Ausgangstransistoren (IGBT's Isolierte Gate Bipolar Transistoren) mit einer festen Frequenz (der Pulsfrequenz) erzeugt. Der gewünschte Strom kann durch die Variation der Ein- und Ausschaltzeit der Ausgangstransistoren generiert werden. Die Ausgangsspannung ist dadurch eine Reihe von Spannungsimpulsen, die in Verbindung mit der Induktivität der Motorspulen zu einem sinusförmigen Motorstrom führt. Die Pulsweitenmodulation wird wie folgt dargestellt

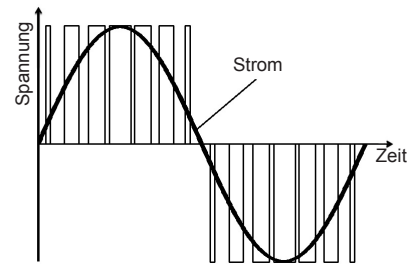

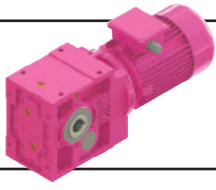

# Genel Bilgiler

## General Information

### Einführung



#### DC MOTORLAR

##### a- Genel Özellikler

DC motorlar, elektronik parçalardaki gelişmeler nedeni ile yeni uygulama alanları bulmuştur. Daha önce çok pahalı olan ve ekonomik olmayan kontrol sistemlerinin yerini ucuz ve kompakt güç kontrol üniteleri almıştır. Yol vermenin kontrol altına alınabildiği, tork ve akım izlenebilirliği, aşırı yüklenmeye karşı elektronik koruma sağlanabilmesi ve daha birçok pahalı olmayan uygulamalar DC motorlarını cazip kılmaya başlamıştır.

##### b- DC Motorların Çalışma İlkeleri

DC motorlar için DC çıkış veren bir doğrultucuya ihtiyaç vardır. Motor armatür sargıları, alan sargıları, komutasyon sargıları ve kompanse sargılar olmak üzere rotorda ve statorda bulunan sargılardan oluşur. Rotora voltaj ve akım karbon fırçalar ve komutator sargılarla ulaştırılır. Bu karbon fırçalar aşındığından DC motorlar belirli periyotlarla bakıma alınmalıdır. İyi kontrol edilebilir özelliklerinden dolayı DC motorlar otomasyon teknolojisinde sıkça kullanılmaktadır.

##### c- DC Motor Çeşitleri

Temel olarak Şönt (Shunt) ve seri sargılı DC motorlar bulunmaktadır. Bu sargıların çeşidine göre moment eğrisi değişmektedir.

##### d- DC Motorlarda Hız Kontrolü

Bu motorlarda devir değişimi DC voltajın değiştirilmesi ile yapılır. Şönt sarımlı DC motorların sıfır yük ile maksimum yük arasındaki davranışı AC motorlara benzer. Devir artan yükte beraber düşer. Bu devir farkı ufak güçlü motorlarda büyük, büyük güçlü motorlarda ise ufaktır. Fakat bu hız farkı DC doğrultucu cihazda armatür voltajı ( $I \times R$ ) ile oynanarak kompanse edilebilir. Hassas hız kontrol gereksinimi olduğunda, tako jeneratörler kullanılabilir. DC motorların gücü aşağıdaki formülden hesaplanır;

$$P_g = U \times I = \frac{P_c}{\eta}$$

$P_g$  : Giriş gücü W  
 $P_c$  : Çıkış gücü W  
 $U$  : Armatür gerilimi V  
 $I$  : Armatür akımı A  
 $\eta$  : Motor verimi

#### DC MOTORS

##### a- General Specifications of DC Motors

*DC drive systems have found new possible applications with the development of the electronic components sector. What was previously extremely expensive and in some cases not economically feasible is nowadays realized by miniaturised power converter technology. Additional functions such as guided startup after a predetermined time, torque and current monitoring with electronic protection against overloading, and many inexpensive special applications have made DC drive systems more attractive.*

##### b- Operating principles of the DC Motors

*The DC motor requires, a converter with DC output. The motor includes windings, such as armature, field, commutation and compensation windings, which are arranged in the stator as well as on rotor. Voltage and current are supplied to the rotor via the carbon brushes and the commutator. The carbon brushes are wearing parts therefore a DC motor requires maintenance at service intervals. While its good control properties, the DC motor is an essential item in automation technology.*

##### c- Types of DC Motors

*Depending on the wiring of the exciting winding or field winding, two basically different variants are regards torque speed characteristics may be distinguished.*

##### d- Speed Control of DC motors

*In DC motors the speed is adjusted by altering the DC voltage. DC shunt wounded motors behave similar to three phase induction motors between no load operation and maximum load. The speed drops with increasing loading of the motor. This difference is greater in small motors and smaller in larger motors. The speed difference can be compensated in the DC converter device by adjusting ( $I \times R$ ). If great control accuracy is required, a speed control with measurement of the actual values by a tachogenerator can be used. The power of DC motor;*

$$P_g = U \times I = \frac{P_c}{\eta}$$

$P_g$  : Input Power W  
 $P_c$  : Output Power W  
 $U$  : Armature Voltage V  
 $I$  : Armature Current A  
 $\eta$  : Motor efficiency

#### DC MOTOREN

##### a- Eigenschaften von DC Motoren

Mit den Entwicklungen bei elektronischen Komponenten haben DC Motoren neue Anwendungsbereiche gefunden. Regelungssysteme, die früher sehr teuer und im manchen Anwendungsfällen ungünstig waren, sind jetzt kompakt und günstig. Bei den DC Motoren ist kontrolliertes Anlauf, Moment- und Stromüberwachung mit Überlastschutz möglich. Es gibt viele günstige Sonderanwendungen für diese Motoren. Wegen oben genannten Eigenschaften werden die DC Motoren immer mehr bei unterschiedlichen Anwendungen benutzt.

##### b- Funktionsprinzip der DC Motoren

Bei DC Motoren ist eine Kommutatorwicklung im Rotor angeordnet, während der magnetische Fluss vom Stator erzeugt wird. Dies kann wiederum mittels einer Erregerwicklung oder durch Permanentmagnete geschehen. Wie bei der Synchronmaschine wird durch das Erregerfeld in der Ankerwicklung eine Wechsellspannung, die bei der Gleichstrommaschine jedoch durch den mechanischen Kommutator und die darauf schleifenden Bürsten in eine Gleichspannung umgeformt wird, induziert.

##### c- Arten von DC Motoren

Es gibt zwei verschiedene Wicklungen, nämlich Shunt- und Serial-Wicklung. Das Drehmoment-Drehzahl-Verhältnis ist für beide Wicklungen unterschiedlich.

##### d- Drehzahl Kontrolle für DC Motoren

Drehzahl von DC Motoren kann man mit Steuerung der DC Spannung ändern. DC Motoren mit Shunt Wicklungen ist ähnlich zu drei phasen AC Motoren zwischen maximalen Last und ohne Last. Drehzahl wird mit der Last reduziert. Mit kleineren Motoren wird dieser Differenz höher mit größeren Motoren kleiner. Der Drehzahlunterschied kann geregelt werden mit ( $I \times R$ ) Veränderung. Wenn eine genaue Kontrolle gebraucht, soll ein Tachogenerator benutzt werden. Leistung des DC Motors;

$$P_g = U \times I = \frac{P_c}{\eta}$$

$P_g$  : Eingangsleistung W  
 $P_c$  : Ausgangsleistung W  
 $U$  : Ankerspannung V  
 $I$  : Ankerstrom A  
 $\eta$  : Wirkungsgrad des Motors

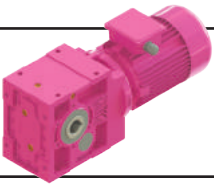

# Genel Bilgiler

## General Information

### Einführung



#### Elektromanyetik Frenler

Bu tip frenlerin iki sürtünme yüzeyi vardır. Fren torku, voltaj uygulanmadığı zaman yayların kuvveti ile oluşturulur. Fren elektromanyetik alanın oluşumu ile serbest kalır. Bobinin beslenmesi ile mıknatıslanan balata baskı pulu, elektromıknatısa doğru çekilir. Bu hareket yayları baskı altına alır ve rotor mili üzerine takılan çoklu kama üzerinde aksiyal yönde serbest hareket edebilen balata serbest kalır. Akım kesildiğinde yayların baskısıyla, balata baskı pulu fren balatasına doğru itilir ve bu hareket rotoru frenler.

#### Fren Çeşitleri

##### a) Soğutmasız tip frenler

Motor fanı çıkarılıp motor kapağı arkasına akupile edilerek kullanılan frenler; genellikle sıkça açılıp kapanmayan ve kısa zaman aralıklarında çalışan sistemlerde tercih edilir.

##### b) Soğutmalı tip frenler

Motor fanı çıkarılıp motor kapağı arkasına akupile edilen ve motorun mili uzatılarak fren ve motorun arkasına alınan fan sayesinde daimi bir hava sirkülasyonu sağlanarak kullanılan frenlerdir. Genellikle uzun süreli çalışan ve kapalı mekanlarda kullanılan sistemlerde tercih edilir.

##### c) Manuel kol sistemli frenler

Çalışma sistemi olarak her iki fren tipinde de kullanılabilir (soğutmalı veya soğutmasız). Özel durumlarda (elektrik kesilmesi; mekanik problemler) üzerinde bulunan bir kol vasıtası ile sistemi yay baskısından kurtararak serbest kalmasını sağlayan frenlerdir. Genellikle manuel olarak sistemin açılması gereken yerlerde (otomatik giriş kapıları, dış cepe boyama asansörleri v.b.) tercih edilir.

#### Fren çalışma voltajları

Elektromanyetik frenler 230V AC veya 400V AC beslemeli olarak sipariş edilebilir. Frenler DC fren olmaları nedeni ile besleme ile fren bobini arasında fren tipine bağlı olarak, yarım dalga, tam dalga doğrultucular veya trafolar kullanılır. Özel olarak belirtilmedikçe 230V beslemeli ve yarım dalga doğrultuculu frenler kullanılmaktadır. Özel durumlar için YILMAZ Redüktöre danışınız.

##### a) 230V AC ile beslenen frenler

Motor klemens kutusundan alınan 230V'luk AC besleme fren tipine bağlı olarak yarım dalga veya tam dalga doğrultucu ile fren bobininin voltajına düşürülür. Fren bobin DC voltajı etiketi üzerinde belirtilmiştir.

##### b) 400V AC ile beslenen DC frenler

Motor klemens kutusundan alınan 400V'luk AC besleme, yarım dalga doğrultucu ile fren bobininin voltajına düşürülür. Fren bobininin DC voltajı etiket üzerinde belirtilmiştir.

##### c) 24V DC Frenler

Kullanılan fren momentinin büyüklüğüne göre besleme transformatörü seçilir. Şebekeden veya motorun klemens kutusundan alınan besleme voltajı transformatörde 29 V'a çevrilen gerilim tam dalga doğrultuculardan geçerek 24V DC'ye çevrilir ve fren bobini beslenir.

#### Electromagnetic Brakes

*This type of brakes has two friction surfaces. Brake torque is generated by springs when no voltage is applied. The brake is electromagnetically released. On exciting the electromagnet means of the current, the armature plate is pulled towards the electromagnet itself, thrust loading the pressure spring and enabling the friction disc which is axially movable on the key, to turn freely. When current fails, the pressured springs drive the armature plate towards the disc, thus braking the motor shaft.*

#### Brake Types

##### a) Brakes without cooling

*This type of brakes are assembled on the back cover of the electric motor. There is no fan on the backside. This brake type is mostly preferred in short working times and short working cycles.*

##### b) Fan cooled brakes

*This type of brakes are assembled on the back cover of electric motor by removing the electric motor fan. A fan is coupled to the backside of the brake by extending the rotor shaft of the electric motor. Fan cooled brakes are preferred in long working times and closed places without airflow.*

##### c) Brakes with hand release

*This brakes can be released by help of an arm. It can be applied to both of the above mentioned brakes and used in special cases (fail of electric current, mechanical problems etc.) These brakes are mostly preferred if operation (re-lasing) without a current is needed (automatic controlled doors, gates, building wall painting elevators etc.).*

#### Working Voltages

*Electromagnetic brakes can be ordered with 230V AC or 400V AC supply voltage. The coil of brakes needs DC voltage and therefore depending on brake type a half wave, a full wave rectifier or transformer should be used between supply and coil voltage. As standard the brakes will be delivered with 230V supply voltage and half wave rectifier, if there is no special request. For special cases please contact YILMAZ Redüktör.*

##### a) Brakes with 230V supply voltage

*230V AC supply voltage from the motor terminal box will be reduced to the coil voltage depending on the brake type with half-wave or full-wave rectifier. DC brake coil voltage is indicated on the label.*

##### b) Brakes with 400V supply voltage

*400V AC supply voltage from the motor terminal box will be reduced to the coil voltage with half-wave rectifier. DC brake coil voltage indicated on the label.*

##### c) 24V DC Brakes

*The transformer's size is selected according to value of brake torque. The current is taken from the electric motor terminal box or from the electric panel and is transformed to 29V DC current. This current is transferred to 24V DC current with full-wave rectifier and supplies brake coil.*

#### Elektromagnetische Bremsen

Die Bremse hat zwei Reibflächen und arbeitet nach dem Ruhestromprinzip. Im stromlosen Zustand wird das Bremsmoment durch den Druck der Feder erzeugt, während die Bremse beim Betrieb elektromagnetisch losgelassen wird. Durch die Erregung der Elektromagneten wird die Ankerscheibe zu den Elektromagneten gezogen und die Feder zusammagedrückt. Dadurch kann sich die Bremsenscheibe, die axial beweglich auf dem Mitnehmer angeordnet ist, frei drehen. Wird der Strom unterbrochen, drücken die Feder die Ankerscheibe gegen die Bremsenscheibe und halten die Motorwelle an.

#### Bremsearten:

##### a) Bremsen ohne Kühlung

Diese Bremsen sind für Kurzlaufzeiten geeignet. Die Lüfterhaube und Lüfter des Motors ist ausgebaut und die Bremse ist an dem Ende der Motorwelle befestigt.

##### b) Bremsen mit Kühlung

Diese Bremsen sind für lange Laufzeiten und kleine, abgedeckte Räume geeignet. Durch die Verlängerung der Motorwelle wurde Lüfter hinter dem Bremse und dem Motor verbunden. Somit wurde eine konstante Lüftung ermöglicht.

##### c) Bremsen mit Hebelarm

Diese Bremsenart kann mit oder ohne Kühlung verwendet werden. Diese Bremsen sind bei der speziellen Fälle, wie keine Spannung an der Leitung, mechanische Probleme usw., anwendbar. Die Bremse wird mit einem Hebelarm manuell betätigt. Diese Bremsen werden am meisten an den Stellen, wo die Lüftung ohne Spannung erfolgen soll, benutzt (automatische Türe, Wandaufzüge).

#### Betriebsspannungen

Elektromagnetische Bremsen können mit 230V AC oder 400V AC Versorgungsspannung bestellt werden. Die Wicklungen der Bremsen brauchen Gleichspannung und deswegen abhängig von Bremsenart zwischen Versorgungsspannung und Wicklungsspannung soll Halbwellen-, Vollweggleichrichter oder Transformator verwendet werden. Als Standard die Bremsen werden mit 230V Versorgungsspannung und Halbwellengleichrichter geliefert.

##### a) Bremsen mit 230V Versorgungsspannung

230V AC Versorgungsspannung von Klemmenkasten wird auf die Wicklungsspannung abhängig von der Bremsentyp mit Halbwellen- oder Vollweggleichrichter reduziert. Wicklungsspannung ist auf dem Etikett angegeben.

##### b) Bremsen mit 400V Versorgungsspannung

400V AC Versorgungsspannung von Klemmenkasten wird auf die Wicklungsspannung mit Halbwellengleichrichter reduziert. Wicklungsspannung ist auf dem Etikett angegeben.

##### c) 24 V DC Bremsen

Die Spannung wird von den Klemmkasten des Motors oder Elektrischrank entnommen. Diese Spannung wird zuerst mittels Transformator zu 24 V reduziert. Danach wird diese Spannung mit Hilfe von Gleichrichter zu Gleichstromspannung umgewandelt. Die Größe des Transformators ist abhängig von der Größe des Bremsmoments.

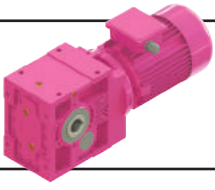

# Genel Bilgiler

## General Information

### Einführung



#### d) Şok ikazlı trafolar

Büyük güçteki ve momentteki frenlerin manyetik doyuma ulaşmaları uzun zaman alır. Şok ikazlı trafolar frenin yay baskısını yenmede gecikmesini engellemek için kullanılır ve zaman rölesi yardımı ile çok kısa bir süre normal besleme voltajının iki katı ile (48V DC) beslenip sistemin ani açılmasını sağlar. Bu sayede gecikmeli açılımda ortaya çıkacak sürtünmeyi engellemeye yarayan bir trafo şeklindedir.

#### Fren bağlantı şekli

##### a) Gecikmeli frenleme

Genellikle sistemin yavaş ve kaydırılarak durması gereken yerlerde tercih edilen bağlantı şeklidir. Vinç yürütme motorlarındaki sarsıntıyı önlemek için gecikmeli bağlantı şekli kullanılır. Frenler fabrika çıkışında gecikmeli bağlantıya uygun ayarlanır.

##### b) Ani frenleme

Genellikle sistemin enerjisi kesildiği anda ani olarak durdurulması gereken sistemlerde kullanılan bağlantı şeklidir. Vinç kaldırma sistemleri, asansör motorlarında kullanılan bağlantı şeklidir.

#### d) Shock voltage supply transformer

Brakes which consist of high power and torques take long time to get in electromagnetic field. Shock voltage supply transformers with time relay are aiming to overcome spring pressure delaying for brakes. Also this transformers provide to open system suddenly by feeding double(48V DC) voltage in a short time and preventing to frictional losses occurring in delayed opening.

#### Connection Types

##### a) Delayed Braking

Generally this type of connection uses in slow and sliding brake intended systems. Delayed connection type using to prevent shock loadings in crane driving systems. Brakes are setting up to delayed connection if any other types are not specified by customer

##### b) Sudden Braking

This type of connections are mostly used in systems when short braking times are needed. The braking torque will be produced as soon as the current fails. These brakes are mostly used in hoisting of lifting units and elevators.

#### d) Trafos mit Schock-Spannung

Diese Transformatoren werden bei großen Bremsen mit hohen Momenten verwendet. Da die große Bremsen eine lange Zeit braucht, um die erforderliche magnetische Feld zu erzeugen, wird an der Bremse kurz 48V Gleichstromspannung angelegt, um die Zeit zur Bildung von magnetischem Feld zu kürzen. Dies ermöglicht kürzere Reibungszeiten beim Start.

#### Schaltungsarten:

##### a) Verspätetes Bremsen

Diese Schaltung wird benutzt, wenn ein langsames und gleitendes Bremsen erforderlich ist. Am meisten wird es bei Fahrtriebemotoren von Aufzügen verwendet. Wenn keine Angabe bei der Bestellung gegeben wird, werden die Bremsen mit verspäteter Schaltung geliefert.

##### b) Schnelles Bremsen:

Allgemein verwendet man diese Schaltung bei Bedarf an plötzlichen Bremsen in dem Augenblick, in dem das System keine Energie mehr erhält. Diese Schaltungsart wird meist bei Kräne und Motoren von Aufzüge verwendet.

**Gecikmeli Frenleme / Delayed Running Brake / Verspätete Bremsung**  
(230 V)

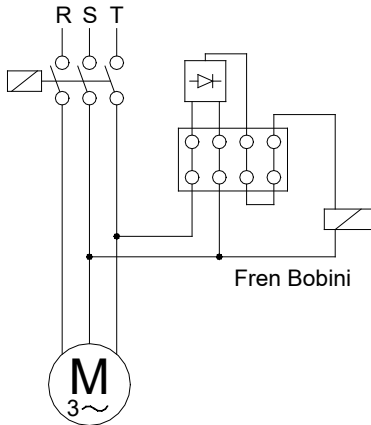

**Ani Frenleme / Sudden Brake / Plötzliche Bremsung**  
(230 V)

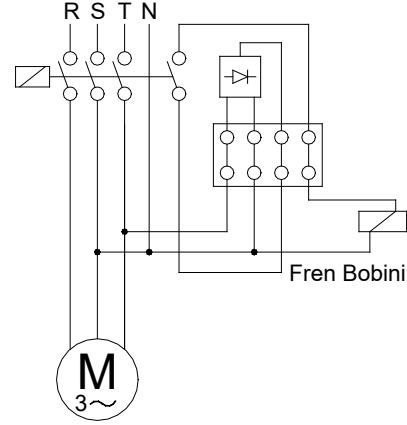

**Gecikmeli Frenleme / Delayed Running Brake / Verspätete Bremsung**  
(24 V)

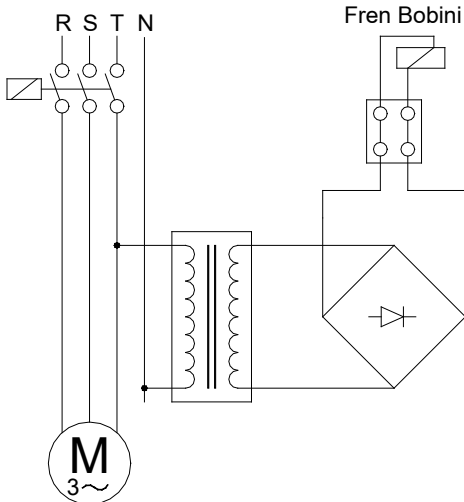

**Ani Frenleme / Sudden Brake / Plötzliche Bremsung**  
(24 V)

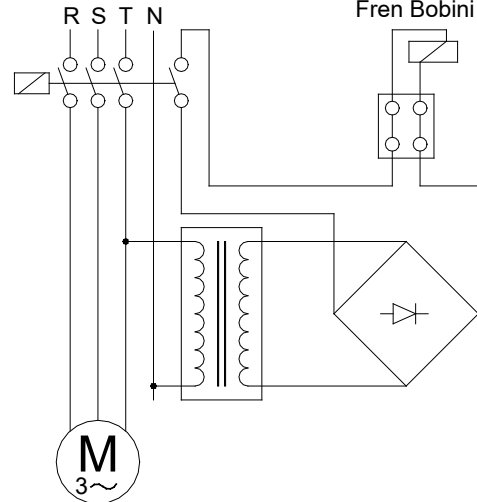

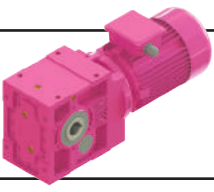

# Genel Bilgiler

## General Information

### Einführung



#### Fren Seçimi:

Doğru bir fren seçimi için aşağıdaki parametreler bilinmelidir.

- $I_{tot}$  [kg.m<sup>2</sup>] : Motor miline indirgenmiş toplam atalet momenti
- $n_0$  [d/dak] : Maksimum motor devir sayısı
- $t_f$  [s] : İstenilen en uzun frenleme zamanı
- $c_t$  : Anahtarın devreye girme zamanı katsayısı (ortalama 0,995).
- $M_L$  [Nm] : Sistemin statik tork ihtiyacı.
- $C_s$  : Emniyet katsayısı ( $C_s \geq 2$  olmalı)

Gerekli fren momenti aşağıdaki şekilde hesaplanır:

a)  $M_L$  Statik yük torku, motor dönüş yönünde (motorun dönüşüne yardımcı olarak, yükün indirilmesi veya hızlandırıcı sabit yük momenti hali):

$$M_{fc} = \frac{(2\pi \times n_0 \div 60) \times I_{tot}}{t_f \times c_t} + M_L$$

b)  $M_L$  Statik yük torku, motor aksi dönüş yönünde (motorun dönüşüne engel olarak, yükün yukarı kaldırılması veya frenleyici sabit yük/direnç momenti hali):

$$M_{fc} = \frac{(2\pi \times n_0 \div 60) \times I_{tot}}{t_f \times c_t} - M_L$$

Yukarıda bulunan sonuç  $C_s$  katsayısı ile çarpılarak ( $C_s \geq 2$ ), fren momenti seçilir;

$$M_f = M_{fc} \times C_s$$

#### Yaklaşım Yolu ile Fren Seçimi:

Eğer yalnızca motorun gücü ve en yüksek devri biliniyor ise :

W [Watt]: Motorun nominal gücü

$$M_f = \frac{W}{\left(\frac{2\pi \times n_0}{60}\right)} \times C_s \quad (C_s \geq 2)$$

#### Brake Selection:

To select a brake correctly the following data are necessary;

- $I_{tot}$  [kg . m<sup>2</sup>] : The total inertia of rotating parts reduced at the motor shaft
- $n_0$  [rpm] : Maximum motor speed.
- $t_f$  [s] : The maximum admitted time of the braking.
- $c_t$  : Coefficient of switch on time (average 0,995).
- $M_L$  [Nm] : Required static torque of system.
- $C_s$  : Safety coefficient ( $C_s \geq 2$ )

The necessary braking torque calculates below;

a) The static load torque  $M_L$ , same direction of motor rotation (Descent of a load or steady resisting torque which favours the rotation of the motor)

$$M_{fc} = \frac{(2\pi \times n_0 \div 60) \times I_{tot}}{t_f \times c_t} + M_L$$

b) The static load torque  $M_L$ , opposes the rotation of the motor (Lifting of a load or steady resisting torque which opposes the rotation of the motor)

$$M_{fc} = \frac{(2\pi \times n_0 \div 60) \times I_{tot}}{t_f \times c_t} - M_L$$

The necessary braking torque will result from the following equation using  $C_s$  ( $C_s \geq 2$ );

$$M_f = M_{fc} \times C_s$$

#### Approximated Brake Selection

Its only the motor power and its maximum speed are known:

W [Watt]: Motor Nominal Power

$$M_f = \frac{W}{\left(\frac{2\pi \times n_0}{60}\right)} \times C_s \quad (C_s \geq 2)$$

#### Bremswahl:

Um die richtige Bremse auszuwählen, braucht man unten aufgelistete Variablen;

- $I_{tot}$  [kg . m<sup>2</sup>] : Die Gesamtträgheit der rotierenden Teile (siehe Anwendungsbeispiele)
- $n_0$  [U/min] : Die höchste Drehzahl des Motors
- $t_f$  [s] : Die längste zulässige Bremszeit
- $c_t$  : Reduktionskoeffizient der Tätigkeitszeit (gemittelt 0,995).
- $M_L$  [Nm] : Vom system benötigtes, statisches Drehmoment.
- $C_s$  : Sicherheitskoeffizient ( $C_s \geq 2$ )

Die benötigte Bremskraft wird wie folgt berechnet:

a) konstantes Belastungsmoment  $M_L$ , das die Motordrehung fördert (konstante Erhöhung der Motorgeschwindigkeit oder Herunterlassen der Last)

$$M_{fc} = \frac{(2\pi \times n_0 \div 60) \times I_{tot}}{t_f \times c_t} + M_L$$

b) konstantes Belastungsmoment  $M_L$ , das sich entgegen der Motordrehung widersetzt (konstante Verminderung der Motorgeschwindigkeit oder Aufheben der Last)

$$M_{fc} = \frac{(2\pi \times n_0 \div 60) \times I_{tot}}{t_f \times c_t} - M_L$$

Wenn die Bremskraft mit dem Sicherheitskoeffizient  $C_s$  ( $C_s \geq 2$ ) multipliziert wird, erhält man die erforderliche Bremskraft;

$$M_f = M_{fc} \times C_s$$

#### Abschätzung zur Bremswahl

Wenn man nur die Motorleistung und die höchste Drehzahl kennt, kann die Bremskraft mit der folgenden Formel annähernd berechnet werden:  
W [Watt] : Nennleistung des Motors

$$M_f = \frac{W}{\left(\frac{2\pi \times n_0}{60}\right)} \times C_s \quad (C_s \geq 2)$$

#### Standart Frenler / Standard Brakes / Standart Bremsen

<b>Fren statik momenti [Nm]</b> Brake Static Torque [Nm] Statische Bremskraft [Nm]	4,5	8	12	16	35	60	80	150	200
<b>Fren Dinamik Momenti [Nm]</b> Brake Dynamic Torque [Nm] Dynamische Bremskraft [Nm]	3,6	6,4	9,6	12,8	28	48	64	120	160
<b>Maksimum Motor Hızı [d/dak]</b> Maximum Motor Speed [rpm] Maximale Motordrehzahl [U/min]	3000	3000	3000	3000	3000	3000	3000	1500	1500
<b>Giriş Gücü [W]</b> Input Power [W] Antriebsleistung [W]	15	20	25	30	45	50	55	60	65

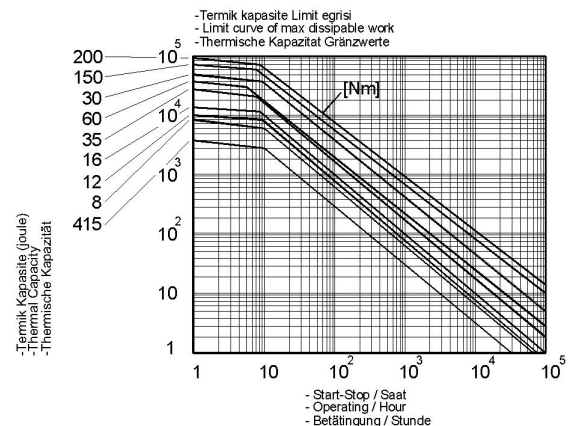

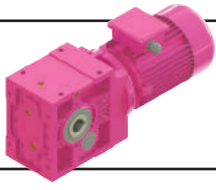

# Genel Bilgiler

## General Information

### Einführung



#### Frenin Termik Kapasitesi

Yukarıdaki seçime ek olarak frenin termik kapasitesinin kontrol edilmesi gerekir. L (joule) olarak gerekli soğutma işi aşağıdaki formüller ile hesaplanır ve "Termik kapasite limit eğrisi" kullanılarak eğrinin altında kalıp kalmadığı kontrol edilir.

a)  $M_L$  Statik yük torku motor dönüş yönünde (motorun dönüşüne yardımcı olarak, yükün indirilmesi hali)

$$L = \frac{I_{tot} \times (2 \pi \times n_0 \div 60)^2}{2} \times \left( \frac{M_f}{M_f - M_L} \right)$$

b)  $M_L$  Statik yük torku motor aksi dönüş yönünde (motorun dönüşüne engel olarak, yükün kaldırılması hali):

$$L = \frac{I_{tot} \times (2 \pi \times n_0 \div 60)^2}{2} \times \frac{M_f}{M_f + M_L}$$

c)  $M_L$  Statik yük torku sabit, motor yönünde veya aksi yönde (kaldırma ve indirme harici hızlandırıcı veya frenleyici sabit bir yük momenti hali).

$$L = \frac{I_{tot} \times (2 \pi \times n_0 \div 60)^2}{2}$$

#### Fren Hava Boşluğunun Ayarı:

Frenin sürekli aynı performansın alınabilmesi için, fren balatasının aşınmasına bağlı olarak, fren hava boşluğu belirli zaman aralıklarında yeniden ayarlanmalıdır. Fren hava boşluğu ayar zaman aralığı ve ayarın yapılması için firmamıza danışınız.

#### Fren Seçim Örneği:

İstenilen en uzun frenleme zamanı: 0,5 sn.  
Motor devri: 1400 d/dak  
Motora indirgenmiş toplam atalet momenti: 0,08 kgm<sup>2</sup>

Gerekli çalışma momenti: 50 Nm

Yük Durumu: Yük motor dönüş yönü ile aynı (Vinçten yük indirilmesi: Saatte dur-kalk sayısı:30)

$$M_{fc} = \frac{(2 \pi \times 1400 \div 60)}{0,5 \times 0,995} + 50 = 73,6 \text{ Nm}$$

$$M_f = 73,6 \times 2 = 147,2 \text{ Nm}$$

Standart frenler tablosundan 150 Nm lik fren seçilebilir.

Gerekli termik kapasite;

$$L = \frac{0,08 \times (2 \pi \times 1400 \div 60)^2}{2} \times \left( \frac{147,2}{147,2 - 50} \right)$$

=1302,0 < 18000 Joule (150 Nm eğrisinden)  
150 Nm lik fren uygun görülüyor.

#### The Thermal Capacity of Brake

The thermal capacity of the brake must also be checked after the above mentioned calculations. The heat dissipation energy L (joule) can be calculated from the following equation and must be checked if the result is under the limit curve shown on "Limit curve of may dissipable work".

a) The static load torque  $M_L$ , favours the rotation of the motor (Descent of a load which favours the rotation of the motor)

$$L = \frac{I_{tot} \times (2 \pi \times n_0 \div 60)^2}{2} \times \left( \frac{M_f}{M_f - M_L} \right)$$

b) The static load torque  $M_L$ , opposes the rotation of the motor (Lifting of a load which opposes the rotation of the motor)

$$L = \frac{I_{tot} \times (2 \pi \times n_0 \div 60)^2}{2} \times \frac{M_f}{M_f + M_L}$$

c) The static load torque  $M_L$ , is constant and opposes or favours the rotation of the motor (except lifting of a load)

$$L = \frac{I_{tot} \times (2 \pi \times n_0 \div 60)^2}{2}$$

#### Adjustment of the air-gap:

In order to obtain the same performance from the brake during its lifetime, the air-gap of the brake must be re-adjusted after a limited time of operation. For the air-gap and the time interval of the adjustment please contact us.

#### Selection Example:

The maximum admitted time for braking 0,5 s  
Motor speed: 1400 rpm  
Total inertia reduced at motor shaft: 0,08 kgm<sup>2</sup>

Required operating torque: 50 Nm

Nature of load: Load direction is same as motor direction (Unloading process: Start-stop time per hour :30)

$$M_{fc} = \frac{(2 \pi \times 1400 \div 60)}{0,5 \times 0,995} + 50 = 73,6 \text{ Nm}$$

$$M_f = 73,6 \times 2 = 147,2 \text{ Nm}$$

From the brake selection table a standard brake of 150 Nm is selected.

Necessary thermal capacity

$$L = \frac{0,08 \times (2 \pi \times 1400 \div 60)^2}{2} \times \left( \frac{147,2}{147,2 - 50} \right)$$

=1302,0 < 18000 Joule (from 150 Nm curve)  
The selected brake with 150 Nm is suitable.

#### Thermische Kapazität der Bremsen

Nach den oben genannten Berechnungen muss die Thermische Kapazität überprüft werden. Die Wärme, d.h. die gebrauchte Energie L, werden mit den folgenden Formeln berechnet. Die gerechnete Kapazitätswerte sollen unter dem Grenzkurve "Thermische Kapazität Grenzwerte" der gewählten Bremse liegen.

a) Konstantes Belastungsmoment  $M_L$ , das die Motordrehung fördert (Herunterlassen der Last)

$$L = \frac{I_{tot} \times (2 \pi \times n_0 \div 60)^2}{2} \times \left( \frac{M_f}{M_f - M_L} \right)$$

b) Konstantes Belastungsmoment  $M_L$ , das sich entgegen der Motordrehung widersetzt (Aufheben der Last)

$$L = \frac{I_{tot} \times (2 \pi \times n_0 \div 60)^2}{2} \times \frac{M_f}{M_f + M_L}$$

c) Konstantes Belastungsmoment  $M_L$ , das sich gegen der Motorbewegung widersetzt oder die Motorrotation fördert (Konstante Verminderung oder Erhöhung der Motorgeschwindigkeit, kein Herunterlassen oder Aufheben der Last)

$$L = \frac{I_{tot} \times (2 \pi \times n_0 \div 60)^2}{2}$$

#### Einstellung des Luftspaltes:

Um eine immer konstant bleibende Bremsfähigkeit zu erhalten, muss das Luftspalt nach einer bestimmten Arbeitszeit neu eingestellt werden. Für die Bestimmung des Luftspaltes und die Einstellzeiten bitten wir Sie um Rückfrage.

#### Beispiel für eine Auswahl:

Die höchste zulässige Bremszeit: 0,5 s  
Motordrehzahl: 1400 U/min  
Gesamträgheit der rotierenden Teile: 0,08 kgm<sup>2</sup>  
Das auf das System wirkende Drehmoment: 50 Nm  
Belastungsart: Drehmoment, das die Motorrotation fördert (Herunterlassen der Last)  
Betätigungen pro Stunde: 30

$$M_{fc} = \frac{(2 \pi \times 1400 \div 60)}{0,5 \times 0,995} + 50 = 73,6 \text{ Nm}$$

$$M_f = 73,6 \times 2 = 147,2 \text{ Nm}$$

Eine Bremse von 150 Nm kann man auswählen.

Die thermische Kapazität;

$$L = \frac{0,08 \times (2 \pi \times 1400 \div 60)^2}{2} \times \left( \frac{147,2}{147,2 - 50} \right)$$

=1302,0 < 18000 Joule (von 150 Nm Kurve) Die ausgewählte 150 Nm Bremse ist ausreichend.



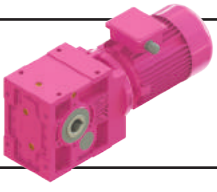

# Güç ve Devir Tabloları

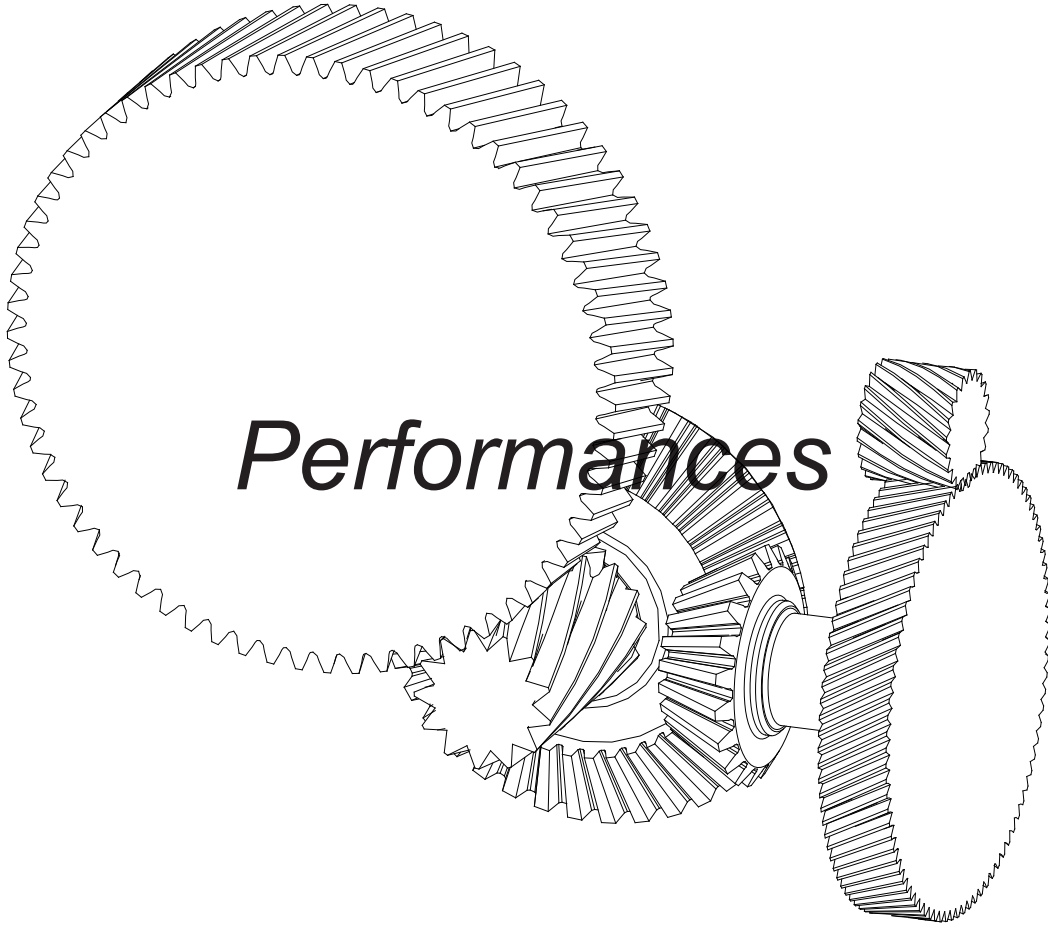

## Leistung und Drehzahlübersicht

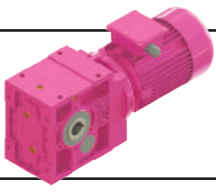

# K Serisi Motorlu Güç Devir Sayfaları

## K Series Geared Motors Performance Tables

### K Serien Getriebemotoren Leistung und Drehzahlübersicht

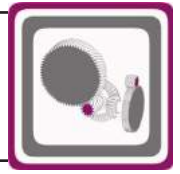

Güç	Çıkış Devri	Çıkış Momenti	Çevrim Oranı	Güv. Rad. Yük Çıkış	Servis Faktörü	Tipi	Anma Akımı	Ağırlık	Ölçü Sayfası	Fiyat Kodu
Power	Output Speeds	Output Torque	Ratio	Per.O. Loads (Output)	Service Factors	Type	Rated Current	Weight	Dim. Page	Price Ref.
Leistung P <sub>g</sub> [kW] P <sub>g</sub> [HP]	Abtriebswelle Drehzahlen n <sub>2</sub> [r.p.m]	Abtriebswelle Drehmomente M <sub>2</sub> [Nm]	Übersetzung i	Zul.Querkräfte (Abtrieb) F <sub>qam</sub> [N]	Betriebsfaktor f <sub>s</sub>	Typ	Nennstrom [A]	Gewicht ~ [kg]	Maße Seite	Preis No.
0,12 0,18	0.25	3535	<b>5587.93</b>	9748	0.8	<b>KR576-63/4a</b>	0,41	156	138	KR001
	0.35	2560	<b>4047.32</b>	24010	1.1					
	0.39	2277	<b>3597.31</b>	26480	1.2					
	0.51	1747	<b>2755.47</b>	30240	1.5					
	0.60	1478	<b>2328.84</b>	31839	1.8					
0.63	1447	<b>2236.28</b>	32013	1.9	<b>KR575-63/4a</b>	0,41	151	138	KR002	
	0.74	1224	<b>1890.04</b>	33217						2.2
	1.02	887	<b>1368.95</b>	34789						3.0
0.49	1825	<b>2873.07</b>	13584	0.8	<b>KR476-63/4a</b>	0,41	113	126	KR003	
	0.53	1696	<b>2663.91</b>	15125						0.9
	0.56	1588	<b>2495.47</b>	16249						1.0
	0.64	1392	<b>2183.54</b>	17982						1.1
0.79	1144	<b>1767.90</b>	19850	1.4	<b>KR475-63/4a</b>	0,41	109	126	KR004	
	0.95	957	<b>1476.60</b>	21035						1.6
	1.0	904	<b>1395.04</b>	21342						1.7
	1.1	791	<b>1218.61</b>	21975						2.0
	1.2	743	<b>1142.99</b>	22193						2.1
	1.4	632	<b>971.77</b>	22775						2.5
	1.6	587	<b>901.03</b>	22985						2.6
	1.7	550	<b>844.06</b>	23155						2.8
0.82	1077	<b>1699.70</b>	8023	0.8	<b>KR376-63/4a</b>	0,41	68	114	KR005	
	0.93	953	<b>1500.87</b>	10240						0.9
	1.0	891	<b>1401.91</b>	11141						0.9
	1.2	753	<b>1184.90</b>	12814						1.1
1.3	709	<b>1094.97</b>	13298	1.2	<b>KR375-63/4a</b>	0,41	64	114	KR006	
	1.4	628	<b>968.01</b>	14079						1.3
	1.7	528	<b>814.20</b>	14948						1.6
	2.0	450	<b>692.22</b>	15540						1.8
	2.4	385	<b>593.11</b>	15995						2.1
	2.6	349	<b>536.75</b>	16225						2.4
	3.0	309	<b>473.96</b>	16497						2.7
	3.2	289	<b>442.71</b>	16597						2.8
	1.6	559	<b>881.79</b>	11261						0.8
1.9		467	<b>735.42</b>	11955	1.0					
1.9	467	<b>719.79</b>	11953	1.0	<b>KR275-63/4a</b>	0,41	29	102	KR008	
	2.1	438	<b>675.13</b>	12142						1.0
	2.4	372	<b>573.99</b>	12551						1.2
	2.8	324	<b>498.55</b>	12822						1.4
	3.2	283	<b>436.24</b>	13025						1.6
	3.9	235	<b>360.73</b>	13251						1.9
	4.7	196	<b>300.85</b>	13434						2.3
	5.6	164	<b>252.20</b>	13566						2.7
	6.5	141	<b>215.91</b>	13659						3.2
	7.0	131	<b>200.35</b>	13683						3.4
	10.6	86	<b>131.68</b>	13856						4.0
10	104	<b>138.53</b>	10321	2,7	<b>KR203-63/4a</b>	0,41	16	94	KR234	
	12	90	<b>119,62</b>	9903						3,1
11	97	<b>129,27</b>	6771	1,4	<b>KR103-63/4a</b>	0,41	12	90	KR235	

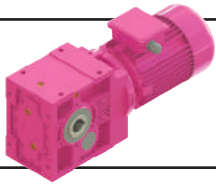

# K Serisi Motorlu Güç Devir Sayfaları

## K Series Geared Motors Performance Tables

### K Serien Getriebemotoren Leistung und Drehzahlübersicht



Güç	Çıkış Devri	Çıkış Momenti	Çevrim Oranı	Güv. Rad. Yük Çıkış	Servis Faktörü	Tipi	Anma Akımı	Ağırlık	Ölçü Sayfası	Fiyat Kodu						
Power	Output Speeds	Output Torque	Ratio	Per.O. Loads (Output)	Service Factors	Type	Rated Current	Weight	Dim. Page	Price Ref.						
Leistung P <sub>g</sub> [kW] P <sub>g</sub> [HP]	Abtriebswelle Drehzahlen n <sub>2</sub> [r.p.m]	Abtriebswelle Drehmomente M <sub>2</sub> [Nm]	Übersetzung i	Zul.Querkräfte (Abtrieb) F <sub>qam</sub> [N]	Betriebsfaktor f <sub>s</sub>	Typ	Nennstrom [A]	Gewicht ~ [kg]	Maße Seite	Preis No.						
0,12 0,18	12	88	<b>118,19</b>	6898	1,6	<b>KR103-63/4a</b>	0,41	12	90	KR235						
	13	79	<b>105,26</b>	7032	1,8											
	16	67	<b>88,87</b>	7176	2,1											
	18	57	<b>76,13</b>	7272	2,5											
	21	50	<b>67,22</b>	7326	2,8											
	22	47	<b>62,79</b>	7350	3,0											
	12	14	74	<b>98,44</b>	4265	1,1	<b>KR003-63/4a</b>	0,41	11	86	KR236					
		16	67	<b>89,62</b>	4452	1,2										
		17	60	<b>80,66</b>	4622	1,3										
		21	51	<b>67,44</b>	4830	1,6										
		25	43	<b>57,16</b>	4964	1,9										
		29	37	<b>48,93</b>	5045	2,2										
		31	34	<b>45,41</b>	5082	2,3										
		40	27	<b>35,34</b>	4816	3,0										
		47	23	<b>29,95</b>	4604	3,6										
55		19	<b>25,64</b>	4409	4,0											
59		18	<b>23,79</b>	4317	4,0											
70	87	12	<b>16,18</b>	4027	4,0	<b>KR002-63/4a</b>	0,41	10	86	KR237						
	95	11	<b>14,73</b>	3906	4,0											
	106	10	<b>13,26</b>	3775	4,0											
	126	8,4	<b>11,09</b>	3561	4,0											
	149	7,1	<b>9,40</b>	3374	4,0											
	174	6,1	<b>8,04</b>	3206	4,0											
	188	5,7	<b>7,46</b>	3128	4,0											
	0,18 0,25	0.11	12428	<b>7938.12</b>	94659						1.2	<b>KR876-71/6a</b>	0,61	644	174	KR009
		0.13	11003	<b>7017.76</b>	100297						1.4					
		0.15	9273	<b>5902.70</b>	106729						1.6					
		0.18	7898	<b>5018.35</b>	111162						1.9					
		0.21	6779	<b>4299.81</b>	114488						2.2					
		0.23	6142	<b>3891.23</b>	116267						2.4					
0.26		5366	<b>3396.71</b>	118321	2.8											
0.30		4737	<b>2996.39</b>	119954	3.2											
0.34		4217	<b>2665.68</b>	121165	3.6											
0.38		3780	<b>2387.89</b>	122196	4.0											
0.43		3281	<b>2074.42</b>	123375	4.0											
0.39		3604	<b>3597.31</b>	7639	0.7	<b>KR576-63/4b</b>	0,60	156	138	KR010						
		0.51	2766	<b>2755.47</b>	21967						1.0					
		0.60	2340	<b>2328.84</b>	25955						1.2					
0.63		2291	<b>2236.28</b>	26363	1.2	<b>KR575-63/4b</b>	0,60	152	138	KR011						
		0.74	1938	<b>1890.04</b>	29009						1.4					
		1.0	1404	<b>1368.95</b>	32301						1.9					
		1.2	1248	<b>1216.74</b>	33070						2.2					
	1.5	959	<b>932.00</b>	34457	2.8											
	1.8	812	<b>787.70</b>	35097	3.3											
0.79	1812	<b>1767.90</b>	13800	0.9	<b>KR475-63/4b</b>	0,60	110	126	KR012							
	0.95	1515	<b>1476.60</b>	16919						1.0						
	1.0	1432	<b>1395.04</b>	17652						1.1						
	1.1	1253	<b>1218.61</b>	19066						1.2						
	1.2	1176	<b>1142.99</b>	19617						1.3						
	1.4	1000	<b>971.77</b>	20767						1.5						
	1.6	929	<b>901.03</b>	21199						1.7						

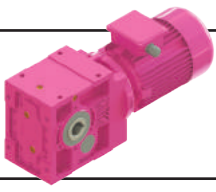

# K Serisi Motorlu Güç Devir Sayfaları

## K Series Geared Motors Performance Tables

### K Serien Getriebemotoren Leistung und Drehzahlübersicht

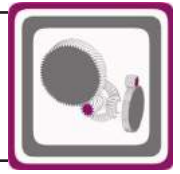

Güç	Çıkış Devri	Çıkış Momenti	Çevrim Oranı	Güv. Rad. Yük Çıkış	Servis Faktörü	Tipi	Anma Akımı	Ağırlık	Ölçü Sayfası	Fiyat Kodu
Power	Output Speeds	Output Torque	Ratio	Per.O. Loads (Output)	Service Factors	Type	Rated Current	Weight	Dim. Page	Price Ref.
Leistung P <sub>g</sub> [kW] P <sub>g</sub> [HP]	Abtriebswelle Drehzahlen n <sub>2</sub> [r.p.m]	Abtriebswelle Drehmomente M <sub>2</sub> [Nm]	Übersetzung i	Zul.Querkräfte (Abtrieb) F <sub>qam</sub> [N]	Betriebsfaktor f <sub>s</sub>	Typ	Nennstrom [A]	Gewicht ~ [kg]	Maße Seite	Preis No.
0,18 0,25	1.7	870	<b>844.06</b>	21557	1.8	<b>KR475-63/4b</b>	0,60	110	126	KR012
	1.9	777	<b>472.63</b>	22032	2.0	<b>KR474-71/6a</b>	0,61	98	122	KR013
	2.1	695	<b>422.88</b>	22449	2.2					
	2.4	611	<b>371.35</b>	22851	2.5					
	2.9	511	<b>310.16</b>	23301	3.0					
	3.1	483	<b>293.03</b>	23456	3.2					
	1.3	1123	<b>1094.97</b>	6953	0.7	<b>KR375-63/4b</b>	0,60	70	114	KR014
	1.4	994	<b>968.01</b>	9575	0.8					
	1.7	837	<b>814.20</b>	11846	1.0					
	2.0	712	<b>692.22</b>	13265	1.2					
2.4	610	<b>593.11</b>	14238	1.3						
2.4	604	<b>367.43</b>	14278	1.4	<b>KR374-71/6a</b>	0,61	60	110	KR015	
3.0	486	<b>295.76</b>	15262	1.7						
3.5	427	<b>259.36</b>	15695	1.9						
3.8	388	<b>367.43</b>	15965	2.1	<b>KR374-63/4b</b>	0,60	59	110	KR016	
4.7	313	<b>295.76</b>	16444	2.6						
5.4	274	<b>259.36</b>	16666	3.0						
2.4	589	<b>573.99</b>	11013	0.8	<b>KR275-63/4b</b>	0,60	29	102	KR017	
2.8	512	<b>498.55</b>	11626	0.9						
3.2	449	<b>436.24</b>	12072	1.0						
3.9	371	<b>360.73</b>	12546	1.2						
4.7	310	<b>300.85</b>	12878	1.5						
5.6	260	<b>252.20</b>	13141	1.7						
6.5	223	<b>215.91</b>	13314	2.0						
7.0	207	<b>200.35</b>	13385	2.2						
7.9	190	<b>113.65</b>	13452	2.4						<b>KR273-71/6a</b>
9.3	162	<b>96.68</b>	13566	2.8						
11	140	<b>83.48</b>	13649	3.2						
12	122	<b>113.65</b>	13715	3.7	<b>KR273-63/4b</b>	0,60	21	98	KR228	
14	104	<b>96.68</b>	13795	4.0						
6,5	244	<b>138,53</b>	8460	1,1	<b>KR203-71/6a</b>	0,61	17	94	KR238	
7,5	211	<b>119,62</b>	9139	1,3						
8,6	185	<b>104,49</b>	9589	1,5						
9,2	173	<b>98,01</b>	9751	1,6						
10	157	<b>138,53</b>	9876	1,8	<b>KR203-63/4b</b>	0,60	16	94	KR239	
12	135	<b>119,62</b>	9522	2,1						
13	118	<b>104,49</b>	9196	2,4						
14	111	<b>98,01</b>	9042	2,5						
17	94	<b>83,32</b>	8656	3,0						
8,5	185	<b>105,26</b>	4121	0,8	<b>KR103-71/6a</b>	0,61	13	90	KR240	
10	157	<b>88,87</b>	5320	0,9						
11	146	<b>129,27</b>	5662	1,0	<b>KR103-63/4b</b>	0,60	12	90	KR241	
12	133	<b>118,19</b>	6004	1,0						
13	119	<b>105,26</b>	6349	1,2						

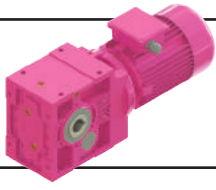

# K Serisi Motorlu Güç Devir Sayfaları

## K Series Geared Motors Performance Tables

### K Serien Getriebemotoren Leistung und Drehzahlübersicht



Güç	Çıkış Devri	Çıkış Momenti	Çevrim Oranı	Güv. Rad. Yük Çıkış	Servis Faktörü	Tipi	Anma Akımı	Ağırlık	Ölçü Sayfası	Fiyat Kodu					
Power	Output Speeds	Output Torque	Ratio	Per.O. Loads (Output)	Service Factors	Type	Rated Current	Weight	Dim. Page	Price Ref.					
Leistung P <sub>g</sub> [kW] P <sub>g</sub> [HP]	Abtriebswelle Drehzahlen n <sub>2</sub> [r.p.m]	Abtriebswelle Drehmomente M <sub>2</sub> [Nm]	Übersetzung i	Zul.Querkräfte (Abtrieb) F <sub>qam</sub> [N]	Betriebsfaktor f <sub>s</sub>	Typ	Nennstrom [A]	Gewicht ~ [kg]	Maße Seite	Preis No.					
0,18 0,25	16	100	88,87	6706	1,4	KR103-63/4b	0,60	12	90	KR241					
	18	86	76,13	6934	1,6										
	21	76	67,22	7065	1,8										
	22	71	62,79	7124	2,0										
	26	60	53,07	6921	2,3										
	32	50	44,32	6581	2,8										
	37	43	38,22	6308	3,1										
	16	101	89,62	3074	0,8						KR003-63/4b	0,60	11	86	KR242
	17	91	80,66	3594	0,9										
	21	76	67,44	4178	1,0										
	25	65	57,16	4515	1,2										
	29	55	48,93	4727	1,4										
	31	52	45,41	4832	1,6										
	40	40	35,34	4575	2,0										
	47	34	29,95	4399	2,4										
	55	29	25,64	4233	2,7										
	59	27	23,79	4153	3,0										
	70	23	19,88	4266	3,5	KR002-63/4b	0,60	10	86	KR243					
	87	19	16,18	3997	4,0										
	95	17	14,73	3879	4,0										
	106	15	13,26	3751	4,0										
	126	13	11,09	3541	4,0										
	149	11	9,40	3357	4,0										
	174	9,2	8,04	3192	4,0										
	188	8,6	7,46	3116	4,0										
	211	7,5	13,26	2998	4,0	KR002-63/2a	0,50	10	86	KR244					
	253	6,3	11,09	2828	4,0										
	298	5,3	9,40	2679	4,0										
	348	4,5	8,04	2546	4,0										
	375	4,2	7,46	2484	4,0										
0,25 0,34	0.15	12900	9052.24	92529	1.2	KR876-71/4a	0,61	646	174	KR019					
	0.18	11330	7938.12	99220	1.3										
	0.20	10031	7017.76	104090	1.5										
	0.24	8454	5902.70	109411	1.8										
	0.28	7201	5018.35	113257	2.1										
	0.33	6180	4299.81	116157	2.4										
	0.36	5599	3891.23	117714	2.7										
	0.41	4892	3396.71	119644	3.1										
	0.47	4319	2996.39	120946	3.5										
	0.53	3845	2665.68	122163	3.9										
	0.59	3446	2387.89	122934	4.0										
	0.20	10178	7156.22	38854	0.8	KR776-71/4a	0,81	390	162	KR020					
	0.22	9079	6380.72	47778	0.9										
	0.25	7996	5610.63	54772	1.0										
	0.31	6444	4516.30	62939	1.2										
	0.35	5660	3960.44	66228	1.4										
	0.40	5012	3501.26	68794	1.6										
	0.44	4690	3203.12	70062	1.7	KR775-71/4a	0,81	390	162	KR021					
	0.49	4155	2838.16	71888	1.9										
	0.55	3720	2539.01	73301	2.2										
	0.68	3035	2066.04	75398	2.6										
	0.78	2620	1786.65	76571	3.1										

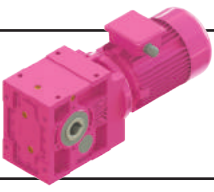

# K Serisi Motorlu Güç Devir Sayfaları

## K Series Geared Motors Performance Tables

### K Serien Getriebemotoren Leistung und Drehzahlübersicht

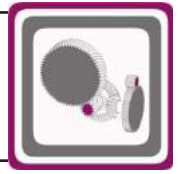

Güç	Çıkış Devri	Çıkış Momenti	Çevrim Oranı	Güv. Rad. Yük Çıkış	Servis Faktörü	Tipi	Anma Akımı	Ağırlık	Ölçü Sayfası	Fiyat Kodu
Power	Output Speeds	Output Torque	Ratio	Per.O. Loads (Output)	Service Factors	Type	Rated Current	Weight	Dim. Page	Price Ref.
Leistung P <sub>g</sub> [kW] P <sub>g</sub> [HP]	Abtriebswelle Drehzahlen n <sub>2</sub> [r.p.m]	Abtriebswelle Drehmomente M <sub>2</sub> [Nm]	Übersetzung i	Zul.Querkräfte (Abtrieb) F <sub>qam</sub> [N]	Betriebsfaktor f <sub>s</sub>	Typ	Nennstrom [A]	Gewicht ~ [kg]	Maße Seite	Preis No.
0,25 0,34	0.36	5475	<b>3844.04</b>	10354	0.8	KR676-71/4a	0,81	316	150	KR022
	0.41	4847	<b>3398.35</b>	22218	0.9					
	0.49	4085	<b>2858.39</b>	30366	1.1					
	0.58	3480	<b>2430.14</b>	35155	1.2					
	0.67	2987	<b>2082.19</b>	38434	1.4					
0.75	0.75	2746	<b>1875.03</b>	39846	1.6	KR675-71/4a	0,81	314	150	KR023
	0.88	2335	<b>1597.25</b>	42037	1.8					
	1.0	2010	<b>1373.07</b>	43655	2.1					
	1.2	1746	<b>1191.60</b>	44795	2.5					
	1.3	1527	<b>1041.68</b>	45771	2.8					
	1.5	1343	<b>915.75</b>	46442	3.2					
0.63	0.63	3248	<b>2236.28</b>	15721	0.8	KR575-71/4a	0,81	154	138	KR024
	0.74	2748	<b>1890.04</b>	22192	1.0					
	1.0	1991	<b>1368.95</b>	28627	1.4					
	1.2	1770	<b>1216.74</b>	30138	1.5					
	1.5	1360	<b>932.00</b>	32506	2.0					
	1.8	1151	<b>787.70</b>	33550	2.3					
1.9	1.9	1096	<b>469.74</b>	33805	2.5	KR574-71/6b	0,83	162	134	KR025
	2.3	927	<b>397.01</b>	34574	2.9					
1.0	1.0	2030	<b>1395.04</b>	10695	0.8	KR475-71/4a	0,81	111	126	KR026
	1.1	1776	<b>1218.61</b>	14231	0.9					
	1.2	1667	<b>1142.99</b>	15434	0.9					
	1.4	1418	<b>971.77</b>	17787	1.1					
	1.6	1318	<b>901.03</b>	18580	1.2					
	1.7	1234	<b>844.06</b>	19201	1.3					
1.9	1.9	1103	<b>472.63</b>	20113	1.4	KR474-71/6b	0,61	116	122	KR027
	2.1	986	<b>422.88</b>	20850	1.6					
	2.4	867	<b>371.35</b>	21545	1.8					
3.0	3.0	709	<b>472.63</b>	22383	2.2	KR474-71/4a	0,81	96	122	KR028
	3.3	634	<b>422.88</b>	22746	2.4					
	3.8	557	<b>371.35</b>	23098	2.8					
	4.5	466	<b>310.16</b>	23530	3.3					
2.0	2.0	1009	<b>692.22</b>	9346	0.8	KR375-71/4a	0,81	70	114	KR029
	2.4	865	<b>593.11</b>	11511	0.9					
2.4	2.4	856	<b>367.43</b>	11607	1.0	KR374-71/6b	0,83	62	110	KR030
	3.0	690	<b>295.76</b>	13487	1.2					
	3.5	605	<b>259.36</b>	14299	1.4					
3.8	3.8	550	<b>367.43</b>	14758	1.5	KR374-71/4a	0,81	62	110	KR031
	4.7	443	<b>295.76</b>	15579	1.8					
	5.4	389	<b>259.36</b>	15953	2.1					
6.1	6.1	354	<b>148.75</b>	16200	2.3	KR373-71/6b	0,83	57	106	KR032
	7.1	303	<b>127.30</b>	16507	2.7					
	8.1	264	<b>110.61</b>	16745	3.1					
3.9	527	<b>360.73</b>	11505	0.9	KR275-71/4a	0,81	32	102	KR033	

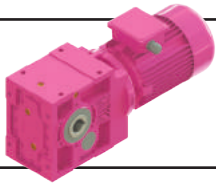

# K Serisi Motorlu Güç Devir Sayfaları

## K Series Geared Motors Performance Tables

### K Serien Getriebemotoren Leistung und Drehzahlübersicht



Güç	Çıkış Devri	Çıkış Momenti	Çevrim Oranı	Güv. Rad. Yük Çıkış	Servis Faktörü	Tipi	Anma Akımı	Ağırlık	Ölçü Sayfası	Fiyat Kodu
Power	Output Speeds	Output Torque	Ratio	Per.O. Loads (Output)	Service Factors	Type	Rated Current	Weight	Dim. Page	Price Ref.
Leistung P <sub>g</sub> [kW] P <sub>g</sub> [HP]	Abtriebswelle Drehzahlen n <sub>2</sub> [r.p.m]	Abtriebswelle Drehmomente M <sub>2</sub> [Nm]	Übersetzung i	Zul.Querkräfte (Abtrieb) F <sub>qam</sub> [N]	Betriebsfaktor f <sub>s</sub>	Typ	Nennstrom [A]	Gewicht ~ [kg]	Maße Seite	Preis No.
0,25 0,34	4.7	440	300.85	12124	1.0	KR275-71/4a	0,81	32	102	KR033
	5.6	369	252.20	12552	1.2					
	6.5	316	215.91	12852	1.4					
	7.0	294	200.35	12972	1.5					
7.9	270	113.65	13103	13103	1.7	KR273-71/6b	0,83	22	98	KR034
	9.3	230	96.68	13279	2.0					
	11	199	83.48	13421	2.3					
12	174	113.65	13533	13533	2.6	KR273-71/4a	0,81	23	98	KR035
	14	148	96.68	13625	3.0					
	17	128	83.48	13706	3.5					
	19	112	72.92	13766	4.0					
6,5	340	138,53	5143	5143	0,8	KR203-71/6b	0,61	18	94	KR245
	7,5	294	119,62	7074	1,0					
	8,6	257	104,49	8142	1,1					
	9,2	241	98,01	8524	1,2					
10	218	138,53	8995	8995	1,3	KR203-71/4a	0,81	17	94	KR246
	12	189	119,62	9058	1,5					
	13	165	104,49	8795	1,7					
	14	155	98,01	8667	1,8					
	17	132	83,32	8341	2,1					
	19	115	72,37	8053	2,4					
	22	100	63,33	7781	2,8					
	27	83	52,37	7396	3,4					
	12	186	118,19	4075	4075					
13		166	105,26	4989	0,8					
16		140	88,87	5832	1,0					
18		120	76,13	6319	1,2					
21		106	67,22	6602	1,3					
22		99	62,79	6721	1,4					
26		84	53,07	6681	1,7					
32		70	44,32	6382	2,0					
37		61	38,22	6137	2,2					
40		56	35,22	6004	2,4					
43		52	32,90	5893	2,5					
50		44	27,81	5624	2,8					
55		41	25,50	5493	5493	2,9	KR102-71/4a	0,81	12	90
	66	34	21,25	5210	3,4					
	72	31	19,43	5074	3,5					
21	106	67,44	2736	2736	0,8	KR003-71/4a	0,81	12	86	KR249
	25	90	57,16	3638	0,9					
	29	77	48,93	4139	1,0					
	31	72	45,41	4313	1,1					
	40	56	35,34	4292	1,4					
	47	47	29,95	4159	1,7					
	55	41	25,64	4028	2,0					
	59	38	23,79	3962	2,1					
70	32	19,88	4216	4216	2,5	KR002-71/4a	0,81	11	86	KR250
	87	26	16,18	3958	2,9					
	95	24	14,73	3845	3,2					

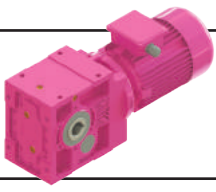

# K Serisi Motorlu Güç Devir Sayfaları

## K Series Geared Motors Performance Tables

### K Serien Getriebemotoren Leistung und Drehzahlübersicht

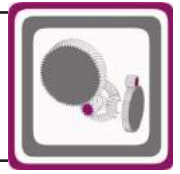

Güç	Çıkış Devri	Çıkış Momenti	Çevrim Oranı	Güv. Rad. Yük Çıkış	Servis Faktörü	Tipi	Anma Akımı	Ağırlık	Ölçü Sayfası	Fiyat Kodu
Power	Output Speeds	Output Torque	Ratio	Per.O. Loads (Output)	Service Factors	Type	Rated Current	Weight	Dim. Page	Price Ref.
Leistung P <sub>g</sub> [kW] P <sub>g</sub> [HP]	Abtriebswelle Drehzahlen n <sub>2</sub> [r.p.m]	Abtriebswelle Drehmomente M <sub>2</sub> [Nm]	Übersetzung i	Zul.Querkräfte (Abtrieb) F <sub>qam</sub> [N]	Betriebsfaktor f <sub>s</sub>	Typ	Nennstrom [A]	Gewicht ~ [kg]	Maße Seite	Preis No.
0,25 0,34	106	21	13,26	3720	3,5	KR002-71/4a	0,81	11	86	KR250
	126	18	11,09	3517	4,0					
	149	15	9,40	3337	4,0					
	174	13	8,04	3175	4,0					
	188	12	7,46	3100	4,0					
	190	12	14,73	3087	4,0	KR002-63/2b	0,67	10	86	KR251
	211	11	13,26	2985	4,0					
	253	8,8	11,09	2817	4,0					
	298	7,5	9,40	2670	4,0					
	348	6,4	8,04	2538	4,0					
375	5,9	7,46	2477	4,0						
0,37 0,50	0.24	12899	5902.70	92531	1.2	KR876-71/4b	1,15	646	174	KR036
	0.28	10986	5018.35	100551	1.4					
	0.33	9429	4299.81	106215	1.6					
	0.36	8543	3891.23	109166	1.8					
	0.41	7464	3396.71	112666	2.0					
	0.47	6590	2996.39	115092	2.3					
	0.53	5866	2665.68	117025	2.6					
	0.59	5258	2387.89	118644	2.9					
	0.67	4564	2074.42	120365	3.3					
	0.74	4239	1891.08	121100	3.5	KR875-71/4b	1,15	644	174	KR037
	0.84	3752	1671.18	122215	4.0					
	0.94	3358	1495.27	123073	4.0					
	0.31	9832	4516.30	41784	0.8	KR776-71/4b	1,15	388	162	KR038
	0.35	8636	3960.44	50902	0.9					
	0.40	7646	3501.26	56756	1.0					
	0.44	7155	3203.12	59387	1.1	KR775-71/4b	1,15	386	162	KR039
	0.49	6340	2838.16	63320	1.3					
	0.55	5675	2539.01	66183	1.4					
	0.68	4631	2066.04	70229	1.7					
	0.78	3997	1786.65	72415	2.0					
	0.90	3465	1547.01	74091	2.3					
	1,0	3033	1353.02	75375	2.6					
	1.2	2676	1192.77	76371	3.0					
	0.58	5309	2430.14	14518	0.8	KR676-71/4b	1,15	228	150	KR040
	0.67	4557	2082.19	25704	0.9					
	0.75	4190	1875.03	29457	1.0	KR675-71/4b	1,15	245	150	KR041
	0.88	3563	1597.25	34566	1.2					
	1.0	3066	1373.07	37921	1.4					
	1.2	2663	1191.60	40327	1.6					
	1.3	2330	1041.68	42055	1.8					
1.5	2050	915.75	43465	2.1						
1.7	1815	809.27	44489	2.4						
1.9	1624	724.08	45302	2.6						
2.2	1429	635.86	46089	3.0						
1.0	3037	1368.95	18825	0.9	KR575-71/4b					
1.2	2701	1216.74	22600	1.0						
1.5	2076	932.00	28025	1.3						
1.8	1756	787.70	30194	1.5						

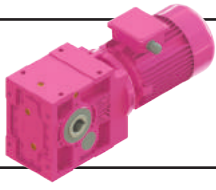

# K Serisi Motorlu Güç Devir Sayfaları

## K Series Geared Motors Performance Tables

### K Serien Getriebemotoren Leistung und Drehzahlübersicht



Güç	Çıkış Devri	Çıkış Momenti	Çevrim Oranı	Güv. Rad. Yük Çıkış	Servis Faktörü	Tipi	Anma Akımı	Ağırlık	Ölçü Sayfası	Fiyat Kodu
Power	Output Speeds	Output Torque	Ratio	Per.O. Loads (Output)	Service Factors	Type	Rated Current	Weight	Dim. Page	Price Ref.
Leistung P <sub>g</sub> [kW] P <sub>g</sub> [HP]	Abtriebswelle Drehzahlen n <sub>2</sub> [r.p.m]	Abtriebswelle Drehmomente M <sub>2</sub> [Nm]	Übersetzung i	Zul.Querkräfte (Abtrieb) F <sub>qam</sub> [N]	Betriebsfaktor f <sub>s</sub>	Typ	Nennstrom [A]	Gewicht ~ [kg]	Maße Seite	Preis No.
0,37 0,50	1.9	1672	<b>469.74</b>	30703	1.6	<b>KR574-80/6a</b>	1,1	159	134	KR043
	2.3	1415	<b>397.01</b>	32180	1.9					
	2.7	1174	<b>328.56</b>	33425	2.3					
	3.0	1075	<b>469.74</b>	33903	2.5	<b>KR574-71/4b</b>	1,15	151	134	KR044
	3.5	910	<b>397.01</b>	34652	3.0					
	1.9	1682	<b>472.63</b>	15277	0.9	<b>KR474-80/6a</b>	1,1	98	122	KR045
	2.1	1505	<b>422.88</b>	17013	1.0					
	2.4	1323	<b>371.35</b>	18554	1.2					
	3.0	1081	<b>472.63</b>	20251	1.4	<b>KR474-71/4b</b>	1,15	96	122	KR046
	3.3	967	<b>422.88</b>	20964	1.6					
	3.8	850	<b>371.35</b>	21636	1.8					
	4.5	711	<b>310.16</b>	22369	2.2					
	4.8	672	<b>293.03</b>	22563	2.3					
	5.9	558	<b>153.47</b>	23177	2.8	<b>KR473-80/6a</b>	1,1	91	118	KR047
	6.6	494	<b>135.98</b>	23440	3.1					
	8.1	403	<b>110.65</b>	23809	3.8					
	3.0	1052	<b>295.76</b>	8519	0.8	<b>KR374-80/6a</b>	1,1	64	110	KR048
	3.5	924	<b>259.36</b>	10673	0.9					
	3.8	840	<b>367.43</b>	11812	1.0	<b>KR374-71/4b</b>	1,15	62	110	KR049
	4.7	676	<b>295.76</b>	13621	1.2					
	5.4	594	<b>259.36</b>	14382	1.4					
	6.1	525	<b>229.29</b>	14954	1.6					
	7.1	462	<b>127.30</b>	15458	1.8	<b>KR373-80/6a</b>	1,1	60	106	KR050
	8.1	402	<b>110.61</b>	15879	2.0					
	9.4	348	<b>148.75</b>	16242	2.4	<b>KR373-71/4b</b>	1,15	58	106	KR051
	11	298	<b>127.30</b>	16546	2.8					
	13	259	<b>110.61</b>	16776	3.2					
	4.7	671	<b>300.85</b>	10276	0.7	<b>KR275-71/4b</b>	1,15	32	102	KR052
	5.6	563	<b>252.20</b>	11244	0.8					
	6.5	483	<b>215.91</b>	11844	0.9					
	7.0	449	<b>200.35</b>	12067	1.0					
	9.3	351	<b>96.68</b>	12650	1.3	<b>KR273-80/6a</b>	1,1	35	98	KR053
	11	303	<b>83.48</b>	12923	1.5					
	12	266	<b>113.65</b>	13113	1.7	<b>KR273-71/4b</b>	1,15	24	98	KR054
	14	226	<b>96.68</b>	13296	2.0					
	17	196	<b>83.48</b>	13429	2.3					
	19	171	<b>72.92</b>	13530	2.6					
	20	161	<b>68.40</b>	13571	2.8					
	24	137	<b>58.15</b>	13662	3.3					
	28	119	<b>50.51</b>	13726	3.8					
	32	104	<b>44.20</b>	13794	4.0					

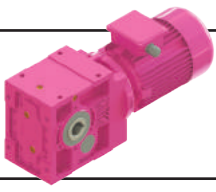

# K Serisi Motorlu Güç Devir Sayfaları

## K Series Geared Motors Performance Tables

### K Serien Getriebemotoren Leistung und Drehzahlübersicht

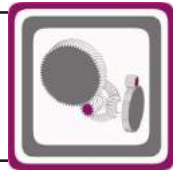

Güç	Çıkış Devri	Çıkış Momenti	Çevrim Oranı	Güv. Rad. Yük Çıkış	Servis Faktörü	Tipi	Anma Akımı	Ağırlık	Ölçü Sayfası	Fiyat Kodu
Power	Output Speeds	Output Torque	Ratio	Per.O. Loads (Output)	Service Factors	Type	Rated Current	Weight	Dim. Page	Price Ref.
Leistung P <sub>g</sub> [kW] P <sub>g</sub> [HP]	Abtriebswelle Drehzahlen n <sub>2</sub> [r.p.m]	Abtriebswelle Drehmomente M <sub>2</sub> [Nm]	Übersetzung i	Zul.Querkräfte (Abtrieb) F <sub>qam</sub> [N]	Betriebsfaktor f <sub>s</sub>	Typ	Nennstrom [A]	Gewicht ~ [kg]	Maße Seite	Preis No.
0,37 0,50	9,2	357	98,01	4160	0,8	KR203-80/6a	1,10	20	94	KR252
	10	324	138,53	5913	0,9	KR203-71/4b	1,15	18	94	KR253
	12	280	119,62	7486	1,0					
	13	245	104,49	8073	1,1					
	14	230	98,01	7994	1,2					
	17	196	83,32	7778	1,4					
	19	170	72,37	7570	1,6					
	22	149	63,33	7362	1,9					
	27	123	52,37	7054	2,3					
	32	103	43,67	6753	2,7					
	38	86	36,61	6458	3,2					
	18	178	76,13	4454	0,8	KR103-71/4b	1,15	14	90	KR254
	21	158	67,22	5283	0,9					
	22	147	62,79	5610	1,0					
	26	125	53,07	6252	1,1					
	32	104	44,32	6029	1,3					
	37	90	38,22	5836	1,5					
	40	83	35,22	5728	1,6					
	43	77	32,90	5636	1,7					
	50	65	27,81	5409	1,9					
	55	61	25,50	5307	2,0					
	66	51	21,25	5055	2,3					
	72	46	19,43	4933	2,4					
	81	41	17,30	4777	2,7					
	96	35	14,61	4554	3,2					
	31	107	45,41	2720	0,8	KR003-71/4b	1,15	13	86	KR256
	40	83	35,34	3809	1,0					
	47	70	29,95	3749	1,1					
	55	60	25,64	3676	1,3					
	59	56	23,79	3636	1,4					
	70	47	19,88	4117	1,7	KR002-71/4b	1,15	12	86	KR257
	87	39	16,18	3882	1,9					
	95	35	14,73	3777	2,1					
	106	32	13,26	3661	2,4					
	126	27	11,09	3469	2,8					
	149	22	9,40	3298	3,1					
	174	19	8,04	3143	3,4					
	188	18	7,46	3070	3,6					
190	18	14,73	3058	3,4	KR002-71/2a					
211	16	13,26	2959	3,8						
253	13	11,09	2796	4,0						
298	11	9,40	2652	4,0						
348	9,6	8,04	2524	4,0						
375	8,9	7,46	2464	4,0						
0,55 0,75	0.41	11095	3396.71	100240	1.4	KR876-80/4a	1,1	652	174	KR055
	0.47	9795	2996.39	105018	1.5					
	0.53	8720	2665.68	108622	1.7					
	0.59	7816	2387.89	111455	1.9					
	0.67	6784	2074.42	114492	2.2					
	0.74	6301	1891.08	115874	2.4	KR875-80/4a	1,1	648	174	KR056

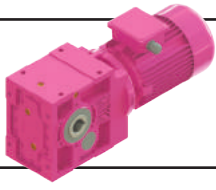

# K Serisi Motorlu Güç Devir Sayfaları

## K Series Geared Motors Performance Tables

### K Serien Getriebemotoren Leistung und Drehzahlübersicht



Güç	Çıkış Devri	Çıkış Momenti	Çevrim Oranı	Güv. Rad. Yük Çıkış	Servis Faktörü	Tipi	Anma Akımı	Ağırlık	Ölçü Sayfası	Fiyat Kodu
Power	Output Speeds	Output Torque	Ratio	Per.O. Loads (Output)	Service Factors	Type	Rated Current	Weight	Dim. Page	Price Ref.
Leistung P <sub>g</sub> [kW] P <sub>g</sub> [HP]	Abtriebswelle Drehzahlen n <sub>2</sub> [r.p.m]	Abtriebswelle Drehmomente M <sub>2</sub> [Nm]	Übersetzung i	Zul.Querkräfte (Abtrieb) F <sub>qam</sub> [N]	Betriebsfaktor f <sub>s</sub>	Typ	Nennstrom [A]	Gewicht ~ [kg]	Maße Seite	Preis No.
0,55 0,75	0.84	5578	1671.18	117767	2.7	KR875-80/4a	1,1	648	174	KR056
	0.94	4992	1495.27	119246	3.0					
	1.1	4391	1313.07	120680	3.4					
	1.3	3676	1096.71	122279	4.0					
	1.5	3213	957.34	123454	4.0					
0,55 0,75	0.44	10636	3203.12	34128	0.8	KR775-80/4a	1,1	390	162	KR057
	0.49	9424	2838.16	45311	0.8					
	0.55	8436	2539.01	52216	0.9					
	0.68	6884	2066.04	60727	1.2					
	0.78	5942	1786.65	65067	1.3					
	0.90	5150	1547.01	68285	1.6					
	1.0	4508	1353.02	70633	1.8					
	1.2	3978	1192.77	72440	2.0					
	1.3	3531	1058.16	73857	2.3					
	1.5	3150	943.49	74993	2.5					
0,55 0,75	1.7	2789	833.78	76015	2.9	KR675-80/4a	1,1	317	150	KR058
	1.9	2496	746.01	76918	3.2					
	0.88	5297	1597.25	14881	0.8					
	1.0	4558	1373.07	25741	0.9					
	1.2	3959	1191.60	31458	1.1					
	1.3	3464	1041.68	35315	1.2					
	1.5	3047	915.75	38041	1.4					
0,55 0,75	1.7	2697	809.27	40111	1.6	KR674-80/6b	1,5	204	146	KR059
	1.9	2414	724.08	41693	1.8					
	2.2	2124	635.86	43065	2.0					
	2.5	1939	363.81	43918	2.2					
	2.8	1717	321.51	44897	2.5					
0,55 0,75	3.3	1461	273.88	45969	2.9	KR575-80/4a	1,1	152	138	KR060
	3.8	1257	235.44	46774	3.4					
	1.5	3085	932.00	18145	0.9					
	1.8	2611	787.70	23541	1.0					
0,55 0,75	1.9	2485	469.74	24708	1.1	KR574-80/6b	1,5	155	134	KR061
	2.3	2103	397.01	27837	1.3					
	2.7	1745	328.56	30251	1.5					
0,55 0,75	3.0	1598	469.74	31147	1.7	KR574-80/4a	1,1	152	134	KR062
	3.5	1352	397.01	32517	2.0					
	4.3	1122	328.56	33679	2.4					
	5.0	960	281.00	34445	2.8					
	5.7	843	246.42	34969	3.2					
0,55 0,75	2.4	1966	371.35	11705	0.8	KR474-80/6b	1,5	100	122	KR063
	3.0	1608	472.63	16042	1.0					
	3.3	1438	422.88	17603	1.1					
	3.8	1264	371.35	19018	1.2					
	4.5	1057	310.16	20407	1.5					
0,55 0,75	4.8	999	293.03	20770	1.6	KR474-80/4a	1,1	98	122	KR064
	5.9	831	153.47	21838	1.9					
	6.6	736	135.98	22314	2.1					
	5.9	831	153.47	21838	1.9					
6.6	736	135.98	22314	2.1						

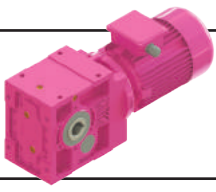

# K Serisi Motorlu Güç Devir Sayfaları

## K Series Geared Motors Performance Tables

### K Serien Getriebemotoren Leistung und Drehzahlübersicht

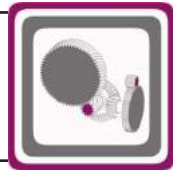

Güç	Çıkış Devri	Çıkış Momenti	Çevrim Oranı	Güv. Rad. Yük Çıkış	Servis Faktörü	Tipi	Anma Akımı	Ağırlık	Ölçü Sayfası	Fiyat Kodu
Power	Output Speeds	Output Torque	Ratio	Per.O. Loads (Output)	Service Factors	Type	Rated Current	Weight	Dim. Page	Price Ref.
Leistung P <sub>g</sub> [kW] P <sub>g</sub> [HP]	Abtriebswelle Drehzahlen n <sub>2</sub> [r.p.m]	Abtriebswelle Drehmomente M <sub>2</sub> [Nm]	Übersetzung i	Zul.Querkräfte (Abtrieb) F <sub>qam</sub> [N]	Betriebsfaktor f <sub>s</sub>	Typ	Nennstrom [A]	Gewicht ~ [kg]	Maße Seite	Preis No.
0,55 0,75	8.1	600	110.65	22954	2.6	KR473-80/6b	1,5	92	118	KR065
	9.1 10 13	535 474 386	153.47 135.98 110.65	23280 23531 23881	2.9 3.3 4.0	KR473-80/4a	1,6	91	118	KR066
4.7 5.4 6.1	1005	295.76	9356	0.8	KR374-80/4a	1,6	64	110	KR067	
	883	259.36	11251	0.9	KR374-80/4a	1,6	64	110	KR067	
	781	229.29	12512	1.0						
7.1 8.1 9.3	688	127.30	13553	1.2	KR373-80/6b	1,5	62	106	KR068	
	599	110.61	14370	1.4	KR373-80/6b	1,5	62	106	KR068	
	527	97.26	16830	1.6						
11 13 14 18	443	127.30	15607	1.9	KR373-80/4a	1,6	60	106	KR069	
	386	110.61	16002	2.1	KR373-80/4a	1,6	60	106	KR069	
	339	97.26	16299	2.4						
	273	78.29	16696	3.0						
7.0	667	200.35	10316	0.7	KR275-80/4a	1,5	35	102	KR070	
9.3 11 12	523	96.68	11531	0.9	KR273-80/6b	1,5	26	98	KR071	
	452	83.48	12043	1.0	KR273-80/6b	1,5	26	98	KR071	
	395	72.92	12399	1.1						
14 17 19 20 24 28 32 38 46	337	96.68	12745	1.3	KR273-80/4a	1,6	27	98	KR072	
	291	83.48	12986	1.5	KR273-80/4a	1,6	27	98	KR072	
	255	72.92	13166	1.8						
	239	68.40	13239	1.9						
	203	58.15	13397	2.2						
	177	50.51	13507	2.5						
	155	44.20	13594	2.9						
	128	36.55	13693	3.5						
	107	30.48	13783	4.0						
	13 14 17 19 22 27 32 38 44 53	365	104.49	3564						0,8
342		98,01	5035	0,8	KR203-80/4a	1,6	20	94	KR259	
291		83,32	6876	1,0						
253		72,37	6800	1,1						
222		63,33	6698	1,3						
183		52,37	6516	1,5						
153		43,67	6311	1,8						
129		36,61	6093	2,2						
111		31,55	5900	2,5						
93		26,31	5656	2,9						
59	84	23,79	5543	3,3	KR202-80/4a	1,6	19	94	KR260	
26 32 37 40 43 50	185	53,07	4116	0,8	KR103-80/4a	1,6	16	90	KR261	
	155	44,32	5373	0,9	KR103-80/4a	1,6	16	90	KR261	
	134	38,22	5361	1,0						
	123	35,22	5293	1,1						
	115	32,90	5233	1,1						
	97	27,81	5073	1,3						

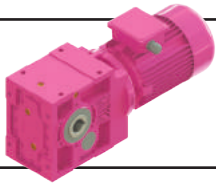

# K Serisi Motorlu Güç Devir Sayfaları

## K Series Geared Motors Performance Tables

### K Serien Getriebemotoren Leistung und Drehzahlübersicht



Güç	Çıkış Devri	Çıkış Momenti	Çevrim Oranı	Güv. Rad. Yük Çıkış	Servis Faktörü	Tipi	Anma Akımı	Ağırlık	Ölçü Sayfası	Fiyat Kodu					
Power	Output Speeds	Output Torque	Ratio	Per.O. Loads (Output)	Service Factors	Type	Rated Current	Weight	Dim. Page	Price Ref.					
Leistung P <sub>g</sub> [kW] P <sub>g</sub> [HP]	Abtriebswelle Drehzahlen n <sub>2</sub> [r.p.m]	Abtriebswelle Drehmomente M <sub>2</sub> [Nm]	Übersetzung i	Zul.Querkräfte (Abtrieb) F <sub>qam</sub> [N]	Betriebsfaktor f <sub>s</sub>	Typ	Nennstrom [A]	Gewicht ~ [kg]	Maße Seite	Preis No.					
0,55 0,75	55	90	25,50	5026	1,3	KR102-80/4a	1,6	15	90	KR262					
	66	75	21,25	4821	1,5										
	72	69	19,43	4719	1,6										
	81	61	17,30	4587	1,8										
	96	52	14,61	4394	2,1										
	112	45	12,51	4218	2,4										
	127	39	11,05	4078	2,5										
	136	37	10,32	4002	2,7										
	161	31	8,72	3819	3,1										
	47	105	29,95	2852	0,8										
	55	90	25,64	3150	0,9										
	59	83	23,79	3147	1,0										
	70	70	19,88	3935	1,1										
	87	57	16,18	3745	1,3										
95	52	14,73	3656	1,4											
106	47	13,26	3556	1,6											
126	39	11,09	3386	1,9											
149	33	9,40	3230	2,1											
174	29	8,04	3087	2,3											
188	27	7,46	3020	2,4											
0,75 1,0	190	26	14,73	3009	2,3	KR002-71/2b	1,27	12	86	KR265					
	211	24	13,26	2915	2,6										
	253	20	11,09	2761	3,0										
	298	17	9,40	2624	3,3										
	348	13	8,04	2500	3,8										
	375	13	7,46	2442	4,0										
	0.47	13357	2996.39	90499	1.1						KR876-80/4b	2,0	650	174	KR073
	0.53	11891	2665.68	96965	1.3										
	0.59	10658	2387.89	101819	1.4										
	0.67	9251	2074.42	106925	1.6										
	0.74	8593	1891.08	109015	1.7						KR875-80/4b	2,0	648	174	KR074
	0.84	7606	1671.18	112150	2.0										
	0.94	6807	1495.27	114417	2.2										
	1.1	5988	1313.07	116660	2.5										
1.3	5013	1096.71	119136	3.0											
1.5	4381	957.34	120635	3.4											
1.7	3868	844.51	121974	3.9											
1.9	3445	751.30	122940	4.0											
0.68	9387	2066.04	45517	0.9	KR775-80/4b	2,0	390	162	KR076						
0.78	8103	1786.65	54213	1.0											
0.90	7023	1547.01	60051	1.1											
1.0	6148	1353.02	64159	1.3											
1.2	5424	1192.77	67308	1.5											
1.3	4815	1058.16	69520	1.7											
1.5	4296	943.49	71358	1.9											
1.7	3803	833.78	72985	2.1											
1.9	3404	746.01	74223	2.4											
2.1	2995	655.11	75424	2.7											
2.3	2889	396.00	75799	2.8						KR774-90S/6	2,1	403	158	KR077	
2.5	2585	354.32	76663	3.1											
2.9	2274	311.14	77510	3.5											

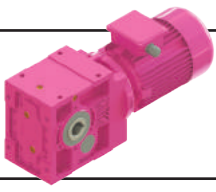

# K Serisi Motorlu Güç Devir Sayfaları

## K Series Geared Motors Performance Tables

### K Serien Getriebemotoren Leistung und Drehzahlübersicht

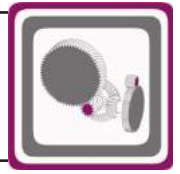

Güç	Çıkış Devri	Çıkış Momenti	Çevrim Oranı	Güv. Rad. Yük Çıkış	Servis Faktörü	Tipi	Anma Akımı	Ağırlık	Ölçü Sayfası	Fiyat Kodu
Power	Output Speeds	Output Torque	Ratio	Per.O. Loads (Output)	Service Factors	Type	Rated Current	Weight	Dim. Page	Price Ref.
Leistung P <sub>g</sub> [kW] P <sub>g</sub> [HP]	Abtriebswelle Drehzahlen n <sub>2</sub> [r.p.m]	Abtriebswelle Drehmomente M <sub>2</sub> [Nm]	Übersetzung i	Zul.Querkräfte (Abtrieb) F <sub>qam</sub> [N]	Betriebsfaktor f <sub>s</sub>	Typ	Nennstrom [A]	Gewicht ~ [kg]	Maße Seite	Preis No.
0,75 1,0	1.2	5399	1191.60	12692	0.8	KR675-80/4b	2,0	318	150	KR078
	1.3	4723	1041.68	23802	0.9					
	1.5	4155	915.75	29712	1.0					
	1.7	3678	809.27	33713	1.2					
	1.9	3292	724.08	36460	1.3					
	2.2	2896	635.86	38983	1.5					
	2.5	2644	363.81	40390	1.6	KR674-90S/6	2,1	297	146	KR079
	2.8	2341	321.51	41994	1.8					
	3.3	1992	273.88	43684	2.2					
	3.9	1700	363.81	44967	2.5	KR674-80/4b	2,0	293	146	KR080
	4.4	1505	321.51	45780	2.9					
	5.1	1280	273.88	46681	3.4					
	1.9	3389	469.74	13357	0.8	KR574-90S/6	2,1	155	134	KR081
	2.3	2868	397.01	20842	0.9					
	2.7	2380	328.56	25633	1.1					
	3.0	2179	469.74	27261	1.2	KR574-80/4b	2,0	153	134	KR082
	3.5	1844	397.01	29618	1.5					
	4.3	1530	328.56	31540	1.8					
	5.0	1309	281.00	32748	2.1					
	5.7	1150	246.42	33557	2.3					
	5.9	1109	237.97	33756	2.4					
6.6	987	211.51	34333	2.7						
3.3	1961	422.88	11790	0.8	KR474-80/4b					
3.8	1724	371.35	14829	0.9						
4.5	1442	310.16	17575	1.1						
4.8	1362	293.03	18241	1.1						
5.9	1133	153.47	20034	1.4	KR473-90S/6	2,1	95	118	KR085	
6.6	1003	135.98	20831	1.5						
8.1	818	119.65	21864	1.9						
9.1	731	153.47	22362	2.1	KR473-80/4b	2,0	92	118	KR086	
10	647	135.98	22755	2.4						
13	528	110.65	23289	2.9						
14	467	97.79	23564	3.3						
6.1	1065	229.29	8243	0.8	KR374-80/4b	2,0	65	110	KR087	
8.1	816	110.61	12158	1.0						KR373-90S/6
9.3	718	97.26	16200	1.1						
11	605	127.30	14339	1.4	KR373-80/4b	2,0	61	106	KR089	
13	527	110.61	14985	1.6						
14	463	97.26	15461	1.8						
18	373	78.29	16101	2.2						
20	328	68.65	16380	2.5						
23	290	60.69	16602	2.8						
11	616	83.48	10783	0.7						KR273-90S/6
12	539	72.92	11416	0.8						

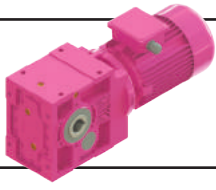

# K Serisi Motorlu Güç Devir Sayfaları

## K Series Geared Motors Performance Tables

### K Serien Getriebemotoren Leistung und Drehzahlübersicht



Güç	Çıkış Devri	Çıkış Momenti	Çevrim Oranı	Güv. Rad. Yük Çıkış	Servis Faktörü	Tipi	Anma Akımı	Ağırlık	Ölçü Sayfası	Fiyat Kodu						
Power	Output Speeds	Output Torque	Ratio	Per.O. Loads (Output)	Service Factors	Type	Rated Current	Weight	Dim. Page	Price Ref.						
Leistung P <sub>g</sub> [kW] P <sub>g</sub> [HP]	Abtriebswelle Drehzahlen n <sub>2</sub> [r.p.m]	Abtriebswelle Drehmomente M <sub>2</sub> [Nm]	Übersetzung i	Zul.Querkräfte (Abtrieb) F <sub>qam</sub> [N]	Betriebsfaktor f <sub>s</sub>	Typ	Nennstrom [A]	Gewicht ~ [kg]	Maße Seite	Preis No.						
0,75 1,0	15	460	96,68	11992	1,0	KR273-80/4b	2,0	28	98	KR091						
	17	398	83,48	12386	1,1											
	19	348	72,92	12668	1,3											
	21	326	68,40	12802	1,4											
	24	277	58,15	13055	1,6											
	28	241	50,51	13228	1,9											
	32	211	44,20	13362	2,1											
	38	175	36,55	13514	2,6											
	46	146	30,48	13627	3,1											
	55	123	25,55	13799	3,5											
	61	111	23,08	13908	3,7											
	73	92	19,08	14033	4,0											
		19	345	72,37	4860						0,8	KR203-80/4b	2,0	21	94	KR266
22		303	63,33	5904	0,9											
27		251	52,37	5876	1,1											
32		209	43,67	5790	1,3											
38		176	36,61	5665	1,6											
44		151	31,55	5537	1,9											
53		126	26,31	5357	2,1											
		59	115	23,79	5301	2,4	KR202-80/4b	2,0	20	94	KR267					
	69	98	20,23	5109	2,9											
	80	85	17,47	4933	3,2											
	40	168	35,22	4778	0,8	KR103-80/4b	2,0	16	90	KR268						
	43	157	32,90	4756	0,8											
	50	133	27,81	4678	0,9											
	55	123	25,50	4709	1,0	KR102-80/4b	2,0	15	90	KR269						
	66	103	21,25	4557	1,1											
	72	94	19,43	4478	1,2											
	81	84	17,30	4374	1,3											
	96	71	14,61	4213	1,6											
	112	61	12,51	4064	1,7											
	127	54	11,05	3942	1,9											
	136	50	10,32	3875	2,0											
	161	42	8,72	3712	2,2											
	192	36	7,29	3538	2,5											
	223	31	6,28	3397	2,9											
		253	27	11,05	3279						3,2	KR102-80/2a	1,8	14	90	KR270
		271	25	10,32	3216						3,2					
	70	96	19,88	3348	0,8	KR002-80/4b	2,0	14	86	KR271						
	87	78	16,18	3557	1,0											
	95	71	14,73	3491	1,0											
	106	64	13,26	3414	1,2											
	126	54	11,09	3275	1,4											
	149	46	9,40	3142	1,5											
	174	39	8,04	3015	1,7											
	188	36	7,46	2954	1,8											
		211	32	13,26	2861						1,9	KR002-80/2a	1,8	13	86	KR272
		253	27	11,09	2717						2,2					
298		23	9,40	2588	2,4											
348		20	8,04	2471	2,8											
375		18	7,46	2415	3,0											

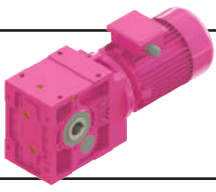

# K Serisi Motorlu Güç Devir Sayfaları

## K Series Geared Motors Performance Tables

### K Serien Getriebemotoren Leistung und Drehzahlübersicht

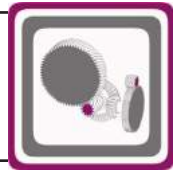

Güç	Çıkış Devri	Çıkış Momenti	Çevrim Oranı	Güv. Rad. Yük Çıkış	Servis Faktörü	Tipi	Anma Akımı	Ağırlık	Ölçü Sayfası	Fiyat Kodu
Power	Output Speeds	Output Torque	Ratio	Per.O. Loads (Output)	Service Factors	Type	Rated Current	Weight	Dim. Page	Price Ref.
Leistung P <sub>g</sub> [kW] P <sub>g</sub> [HP]	Abtriebswelle Drehzahlen n <sub>2</sub> [r.p.m]	Abtriebswelle Drehmomente M <sub>2</sub> [Nm]	Übersetzung i	Zul.Querkräfte (Abtrieb) F <sub>qam</sub> [N]	Betriebsfaktor f <sub>s</sub>	Typ	Nennstrom [A]	Gewicht ~ [kg]	Maße Seite	Preis No.
1,1 1,5	0.74	12603	<b>1891.08</b>	94084	1.2	<b>KR875-90S/4</b>	2,6	652	174	KR093
	0.84	11155	<b>1671.18</b>	99924	1.3					
	0.94	9983	<b>1495.27</b>	104294	1.5					
	1.1	8782	<b>1313.07</b>	108577	1.7					
	1.3	7352	<b>1096.71</b>	112817	2.0					
	1.5	6425	<b>957.34</b>	115438	2.3					
	1.7	5674	<b>844.51</b>	117428	2.6					
	1.9	5052	<b>751.30</b>	118989	3.0					
2.1 2.3 2.7	4686	<b>438.70</b>	88709	3.2	<b>KR874-90L/6</b>	2,7	645	170	KR094	
	4110	<b>383.99</b>	90572	3.6						
	3642	<b>339.70</b>	92130	4.0						
0.9 1.0 1.2 1.3 1.5 1.7 1.9 2.1	10301	<b>1547.01</b>	37673	0.8	<b>KR775-90S/4</b>	2,6	394	162	KR096	
	9017	<b>1353.02</b>	48196	0.9						
	7955	<b>1192.77</b>	55013	1.0						
	7062	<b>1058.16</b>	59852	1.1						
	6301	<b>943.49</b>	63565	1.3						
	5578	<b>833.78</b>	66563	1.4						
	4992	<b>746.01</b>	68852	1.6						
	4392	<b>655.11</b>	71017	1.8						
2.3 2.5 2.9 3.2	4237	<b>396.00</b>	71573	1.9	<b>KR774-90L/6</b>	3,0	344	158	KR097	
	3792	<b>354.32</b>	73057	2.1						
	3336	<b>311.14</b>	74491	2.4						
	2988	<b>278.35</b>	75616	2.7						
3.5 4.0	2724	<b>396.00</b>	76275	2.9	<b>KR774-90S/4</b>	2,6	365	158	KR098	
	2438	<b>354.32</b>	77070	3.3						
1.7 1.9 2.2	5395	<b>809.27</b>	12748	0.8	<b>KR675-90S/4</b>	2,6	252	150	KR099	
	4828	<b>724.08</b>	22352	0.9						
	4248	<b>635.86</b>	28869	1.0						
2.5 2.8 3.3	3879	<b>363.81</b>	32128	1.1	<b>KR674-90L/6</b>	3,0	267	146	KR100	
	3433	<b>321.51</b>	35505	1.3						
	2921	<b>273.88</b>	38803	1.5						
3.9 4.4 5.1 6.0 6.9	2493	<b>363.81</b>	41205	1.7	<b>KR674-90S/4</b>	2,6	265	146	KR101	
	2207	<b>321.51</b>	42659	1.9						
	1878	<b>273.88</b>	44206	2.3						
	1617	<b>235.44</b>	45341	2.7						
	1405	<b>204.32</b>	46205	3.1						
3.0 3.5 4.3 5.0 5.7 5.9 6.7 7.7 8.8 10 12	3195	<b>469.74</b>	16549	0.8	<b>KR574-90S/4</b>	2,6	154	134	KR102	
	2704	<b>397.01</b>	22613	1.0						
	2244	<b>328.56</b>	26756	1.2						
	1920	<b>281.00</b>	29110	1.4						
	1687	<b>246.42</b>	30614	1.6						
	1627	<b>237.97</b>	30976	1.7						
	1447	<b>211.51</b>	32059	1.9						
	1239	<b>180.90</b>	33143	2.2						
	1088	<b>158.64</b>	33871	2.5						
	964	<b>140.24</b>	34445	2.8						
	813	<b>117.96</b>	35107	3.3						
5.9	1664	<b>153.47</b>	15735	0.9	<b>KR473-90L/6</b>	3,0	98	118	KR103	

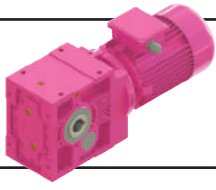

# K Serisi Motorlu Güç Devir Sayfaları

## K Series Geared Motors Performance Tables

### K Serien Getriebemotoren Leistung und Drehzahlübersicht



Güç	Çıkış Devri	Çıkış Momenti	Çevrim Oranı	Güv. Rad. Yük Çıkış	Servis Faktörü	Tipi	Anma Akımı	Ağırlık	Ölçü Sayfası	Fiyat Kodu
Power	Output Speeds	Output Torque	Ratio	Per.O. Loads (Output)	Service Factors	Type	Rated Current	Weight	Dim. Page	Price Ref.
Leistung P <sub>g</sub> [kW] P <sub>g</sub> [HP]	Abtriebswelle Drehzahlen n <sub>2</sub> [r.p.m]	Abtriebswelle Drehmomente M <sub>2</sub> [Nm]	Übersetzung i	Zul.Querkräfte (Abtrieb) F <sub>qam</sub> [N]	Betriebsfaktor f <sub>s</sub>	Typ	Nennstrom [A]	Gewicht ~ [kg]	Maße Seite	Preis No.
1,1 1,5	6.6	1474	<b>135.98</b>	17461	1.1	<b>KR473-90L/6</b>	3,0	98	118	KR103
	8.1	1202	<b>110.65</b>	19524	1.3					
	9.1	1072	<b>153.47</b>	20444	1.4	<b>KR473-90S/4</b>	2,6	96	118	KR104
	10	950	<b>135.98</b>	21166	1.6					
	13	775	<b>110.65</b>	22110	2.0					
	14	685	<b>97.79</b>	22573	2.3					
	16	613	<b>87.49</b>	22899	2.5					
	18	539	<b>76.83</b>	23251	2.9					
	22	451	<b>64.17</b>	23612	3.4					
		8.1	1199	<b>110.61</b>	4985					
9.2		1055	<b>97.26</b>	8585	0.8					
12		850	<b>78.29</b>	11723	1.0					
	13	773	<b>110.61</b>	12699	1.1	<b>KR373-90S/4</b>	2,6	65	106	KR106
	14	680	<b>97.26</b>	13655	1.2					
	18	548	<b>78.29</b>	14817	1.5					
	20	481	<b>68.65</b>	15331	1.7					
	23	426	<b>60.69</b>	15726	1.9					
	27	359	<b>51.05</b>	16173	2.3					
	32	305	<b>43.40</b>	16514	2.7					
	38	262	<b>37.19</b>	16759	3.1					
	17	583	<b>83.48</b>	11082	0.8	<b>KR273-90S/4</b>	2,6	31	98	KR107
	19	510	<b>72.92</b>	11637	0.9					
	20	479	<b>68.40</b>	11862	0.9					
	24	407	<b>58.15</b>	12328	1.1					
	28	354	<b>50.51</b>	12633	1.3					
	32	310	<b>44.20</b>	12888	1.5					
	38	257	<b>36.55</b>	13155	1.8					
	46	215	<b>30.48</b>	13348	2.1					
	55	180	<b>25.55</b>	13573	2.4					
	61	163	<b>23.08</b>	13711	2.5					
	73	135	<b>19.08</b>	13895	2.9					
	88	113	<b>15.92</b>	14030	3.3					
	105	95	<b>13.34</b>	14141	3.7					
	117	85	<b>12.00</b>	14289	2.9					
141	70	<b>9.92</b>	13589	3.4						
169	59	<b>8.28</b>	12942	3.9						
202	49	<b>6.94</b>	12334	4.0						
	27	367	<b>52,37</b>	3288	0,8	<b>KR203-90S/4</b>	2,6	24	94	KR273
	32	307	<b>43,67</b>	4803	0,9					
	38	258	<b>36,61</b>	4860	1,1					
	44	222	<b>31,55</b>	4859	1,3					
	53	186	<b>26,31</b>	4805	1,4					
	59	169	<b>23,79</b>	4871	1,7	<b>KR202-90S/4</b>	2,6	23	94	KR274
	69	144	<b>20,23</b>	4745	1,9					
	80	125	<b>17,47</b>	4619	2,2					
	92	109	<b>15,26</b>	4496	2,4					
	98	102	<b>14,32</b>	4436	2,5					
	115	87	<b>12,17</b>	4281	2,8					
	132	76	<b>10,57</b>	4142	3,1					
	62	162	<b>14,61</b>	4111	0,8	<b>KR102-90L/6</b>	3,0	20	90	KR275
	72	139	<b>12,51</b>	4051	0,9					

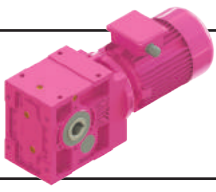

# K Serisi Motorlu Güç Devir Sayfaları

## K Series Geared Motors Performance Tables

### K Serien Getriebemotoren Leistung und Drehzahlübersicht

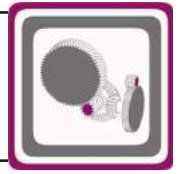

Güç	Çıkış Devri	Çıkış Momenti	Çevrim Oranı	Güv. Rad. Yük Çıkış	Servis Faktörü	Tipi	Anma Akımı	Ağırlık	Ölçü Sayfası	Fiyat Kodu
Power	Output Speeds	Output Torque	Ratio	Per.O. Loads (Output)	Service Factors	Type	Rated Current	Weight	Dim. Page	Price Ref.
Leistung P <sub>g</sub> [kW] P <sub>g</sub> [HP]	Abtriebswelle Drehzahlen n <sub>2</sub> [r.p.m]	Abtriebswelle Drehmomente M <sub>2</sub> [Nm]	Übersetzung i	Zul.Querkräfte (Abtrieb) F <sub>qam</sub> [N]	Betriebsfaktor f <sub>s</sub>	Typ	Nennstrom [A]	Gewicht ~ [kg]	Maße Seite	Preis No.
1,1 1,5	81	123	17,30	3994	0,9	KR102-90S/4	2,6	18	90	KR276
	96	104	14,61	3894	1,1					
	112	89	12,51	3791	1,2					
	127	79	11,05	3702	1,3					
	136	74	10,32	3651	1,4					
	161	62	8,72	3523	1,5					
	192	52	7,29	3381	1,7					
	223	45	6,28	3262	2,0					
	253	39	11,05	3160	2,2	KR102-80/2b	2,4	15	90	KR277
	271	37	10,32	3105	2,2					
	321	31	8,72	2970	2,6					
	384	26	7,29	2828	2,9					
	446	22	6,28	2714	3,1					
	106	94	13,26	3099	0,8	KR002-90S/4	2,6	17	86	KR278
	126	79	11,09	3033	0,9					
	149	67	9,40	2951	1,0					
	174	58	8,04	2862	1,1					
	188	53	7,46	2816	1,2					
	211	47	13,26	2744	1,3	KR002-80/2b	2,4	14	86	KR279
	253	40	11,09	2626	1,5					
	298	34	9,40	2515	1,6					
	348	29	8,04	2410	1,9					
	375	27	7,46	2360	2,1					
	1,5 2,0	0.94	13614	1495.27	89316	1.1	KR875-90L/4	3,5	654	174
1.1		11976	1313.07	96588	1.3					
1.3		10026	1096.71	99692	1.5					
1.5		8762	957.34	103733	1.7					
1.7		7737	844.51	106807	1.9					
1.9		6889	751.30	109174	2.2					
2.1		6391	438.70	110488	2.3	KR874-100L/6				
2.3		5605	383.99	112542	2.7					
2.6		4967	339.70	114124	3.0					
1.3		9630	1058.16	43553	0.8	KR775-90L/4	3,5	423	162	KR112
1.5		8592	943.49	51103	0.9					
1.7		7606	833.78	56993	1.1					
1.9		6808	746.01	61179	1.2					
2.1		5989	655.11	64836	1.3					
2.3		5778	396.00	65738	1.4	KR774-100L/6	3,5	410	158	KR113
2.5		5171	354.32	68182	1.5					
2.9		4549	311.14	70492	1.8					
3.2		4074	278.35	72208	2.0					
3.5		3714	396.00	73306	2.2	KR774-90L/4	3,5	405	158	KR114
4.0		3324	354.32	74526	2.4					
4.5		2924	311.14	75815	2.7					
5.0		2619	278.35	76632	3.1					
5.8		2262	240.71	77566	3.5					
2.5		5289	363.81	15099	0.8	KR674-100L/6	3,5	304	146	KR115
2.8		4682	321.51	24242	0.9					

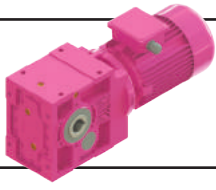

# K Serisi Motorlu Güç Devir Sayfaları

## K Series Geared Motors Performance Tables

### K Serien Getriebemotoren Leistung und Drehzahlübersicht



Güç	Çıkış Devri	Çıkış Momenti	Çevrim Oranı	Güv. Rad. Yük Çıkış	Servis Faktörü	Tipi	Anma Akımı	Ağırlık	Ölçü Sayfası	Fiyat Kodu				
Power	Output Speeds	Output Torque	Ratio	Per.O. Loads (Output)	Service Factors	Type	Rated Current	Weight	Dim. Page	Price Ref.				
Leistung P <sub>g</sub> [kW] P <sub>g</sub> [HP]	Abtriebswelle Drehzahlen n <sub>2</sub> [r.p.m]	Abtriebswelle Drehmomente M <sub>2</sub> [Nm]	Übersetzung i	Zul.Querkräfte (Abtrieb) F <sub>qam</sub> [N]	Betriebsfaktor f <sub>s</sub>	Typ	Nennstrom [A]	Gewicht ~ [kg]	Maße Seite	Preis No.				
1,5 2,0	3.3	3983	<b>273.88</b>	31251	1.1	<b>KR674-100L/6</b>	3,5	304	146	KR115				
	3.8	3400	<b>363.81</b>	35740	1.3	<b>KR674-90L/4</b>	3,5	298	146	KR116				
	4.4	3010	<b>321.51</b>	38334	1.4									
	5.1	2561	<b>273.88</b>	40848	1.7									
	5.9	2205	<b>235.44</b>	42678	2.0									
	6.9	1916	<b>204.32</b>	44093	2.2									
	7.8	1677	<b>178.62</b>	45118	2.6									
	8.9	1476	<b>157.02</b>	45936	2.9									
	4.3	3059	<b>328.56</b>	18493	0.9	<b>KR574-90L/4</b>	3,5	158	134	KR117				
	5.0	2618	<b>281.00</b>	23465	1.0									
5.7	2300	<b>246.42</b>	26295	1.2										
5.9	2218	<b>237.97</b>	26951	1.2										
6.6	1974	<b>211.51</b>	28762	1.4										
7.2	1857	<b>125.51</b>	29594	1.5	<b>KR573-100L/6</b>	3,5	151	130	KR118					
8.2	1627	<b>109.86</b>	31010	1.7										
9.3	1441	<b>97.19</b>	32115	1.9										
11	1219	<b>82.14</b>	33229	2.2										
13	1000	<b>67.37</b>	34273	2.7										
15	884	<b>59.49</b>	34795	3.1										
8.1	1638	<b>110.65</b>	15902	0.9						<b>KR473-100L/6</b>	3,5	105	118	KR119
9.1	1464	<b>153.47</b>	17616	1.1										
10	1297	<b>135.98</b>	18904	1.2	<b>KR473-90L/4</b>	3,5	98	118	KR120					
13	1057	<b>110.65</b>	20504	1.5										
14	935	<b>97.79</b>	21250	1.7										
16	837	<b>87.49</b>	21778	1.9										
18	736	<b>76.83</b>	22263	2.1										
22	615	<b>64.17</b>	22880	2.5										
23	582	<b>60.63</b>	23035	2.7										
13	1055	<b>110.61</b>	8645	0.8						<b>KR373-90L/4</b>	3,5	67	106	KR121
14	928	<b>97.26</b>	10733	0.9										
18	748	<b>78.29</b>	12947	1.1										
20	657	<b>68.65</b>	13855	1.2										
23	581	<b>60.69</b>	14526	1.4										
27	489	<b>51.05</b>	15258	1.7										
32	417	<b>43.40</b>	15795	2.0										
38	357	<b>37.19</b>	16179	2.3										
42	324	<b>33.65</b>	16391	2.5										
24	556	<b>58.15</b>	11297	0.8	<b>KR273-90L/4</b>	3,5	33	98	KR122					
28	483	<b>50.51</b>	11830	0.9										
32	423	<b>44.20</b>	12228	1.1										
38	351	<b>36.55</b>	12652	1.3										
46	293	<b>30.48</b>	12978	1.5										
55	246	<b>25.55</b>	13298	1.7										
61	223	<b>23.08</b>	13483	1.8										
73	184	<b>19.08</b>	13706	2.1										
88	154	<b>15.92</b>	13898	2.4										
105	129	<b>13.34</b>	14041	2.7										
117	116	<b>12.00</b>	14005	2.2										
141	96	<b>9.92</b>	13354	2.5										
169	80	<b>8.28</b>	12746	2.9										
202	67	<b>6.94</b>	12170	3.3										

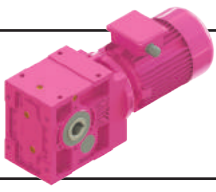

# K Serisi Motorlu Güç Devir Sayfaları

## K Series Geared Motors Performance Tables

### K Serien Getriebemotoren Leistung und Drehzahlübersicht

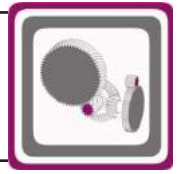

Güç	Çıkış Devri	Çıkış Momenti	Çevrim Oranı	Güv. Rad. Yük Çıkış	Servis Faktörü	Tipi	Anma Akımı	Ağırlık	Ölçü Sayfası	Fiyat Kodu	
Power	Output Speeds	Output Torque	Ratio	Per.O. Loads (Output)	Service Factors	Type	Rated Current	Weight	Dim. Page	Price Ref.	
Leistung P <sub>g</sub> [kW] P <sub>g</sub> [HP]	Abtriebswelle Drehzahlen n <sub>2</sub> [r.p.m]	Abtriebswelle Drehmomente M <sub>2</sub> [Nm]	Übersetzung i	Zul.Querkräfte (Abtrieb) F <sub>qam</sub> [N]	Betriebsfaktor f <sub>s</sub>	Typ	Nennstrom [A]	Gewicht ~ [kg]	Maße Seite	Preis No.	
1,5 2,0	38	352	<b>36,61</b>	3844	0,8	KR203-90L/4	3,5	26	94	KR280	
	44	303	<b>31,55</b>	4010	0,9						
	53	253	<b>26,31</b>	4121	1,0						
	59	231	<b>23,79</b>	4370	1,2	KR202-90L/4	3,5	25	94	KR281	
	69	197	<b>20,23</b>	4321	1,4						
	80	170	<b>17,47</b>	4254	1,6						
	92	149	<b>15,26</b>	4178	1,7						
	98	140	<b>14,32</b>	4139	1,8						
	115	119	<b>12,17</b>	4029	2,1						
	132	103	<b>10,57</b>	3924	2,3						
	151	91	<b>9,25</b>	3819	2,5						
	183	75	<b>7,65</b>	3664	2,9						
	220	63	<b>6,38</b>	3512	3,3						
	96	142	<b>14,61</b>	3521	0,8	KR102-90L/4	3,5	21	90	KR282	
	112	121	<b>12,51</b>	3473	0,9						
	127	108	<b>11,05</b>	3422	0,9						
	136	101	<b>10,32</b>	3391	1,0						
	161	85	<b>8,72</b>	3304	1,1						
	192	71	<b>7,29</b>	3198	1,3						
	223	61	<b>6,28</b>	3105	1,5						
		253	54	<b>11,05</b>	3024						1,6
271		50	<b>10,32</b>	2978	1,6						
321		42	<b>8,72</b>	2863	1,9						
384		36	<b>7,29</b>	2739	2,1						
446		31	<b>6,28</b>	2637	2,3						
	149	92	<b>9,40</b>	2671	0,8	KR002-90L/4	3,5	20	86	KR284	
	174	79	<b>8,04</b>	2640	0,8						
	188	73	<b>7,46</b>	2618	0,9						
	298	46	<b>9,40</b>	2414	1,2	KR002-90S/2	3,3	18	86	KR285	
	348	39	<b>8,04</b>	2329	1,4						
	375	36	<b>7,46</b>	2287	1,5						
2,2 3,0	1.5	12851	<b>957.34</b>	88777	1.2	KR875-100L/4a	5,1	680	174	KR124	
	1.7	11348	<b>844.51</b>	94943	1.3						
	1.9	10104	<b>751.30</b>	99325	1.5						
	2.1	9058	<b>673.01</b>	102788	1.7						
		2.3	8221	<b>383.99</b>	105381	1.8	KR874-112M/6	5,1	677	170	KR125
		2.7	7285	<b>339.70</b>	108113	2.1					
		3.2	6026	<b>438.70</b>	111461	2.5	KR874-100L/4a	5,1	689	170	KR126
		3.7	5285	<b>383.99</b>	113349	2.8					
		4.1	4683	<b>339.70</b>	114803	3.2					
		4.9	3967	<b>287.10</b>	116446	3.8					
		6.0	3258	<b>235.47</b>	118066	4.0					
		1.9	9985	<b>746.01</b>	40584	0.8	KR775-100L/4a	5,1	402	162	KR127
		2.1	8785	<b>655.11</b>	49825	0.9					
		2.3	8474	<b>396.00</b>	51853	0.9	KR774-112M/6	5,1	386	158	KR128
		2.5	7584	<b>354.32</b>	57118	1.1					

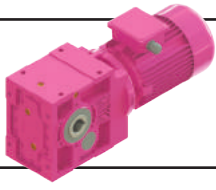

# K Serisi Motorlu Güç Devir Sayfaları

## K Series Geared Motors Performance Tables

### K Serien Getriebemotoren Leistung und Drehzahlübersicht



Güç	Çıkış Devri	Çıkış Momenti	Çevrim Oranı	Güv. Rad. Yük Çıkış	Servis Faktörü	Tipi	Anma Akımı	Ağırlık	Ölçü Sayfası	Fiyat Kodu					
Power	Output Speeds	Output Torque	Ratio	Per.O. Loads (Output)	Service Factors	Type	Rated Current	Weight	Dim. Page	Price Ref.					
Leistung P <sub>g</sub> [kW] P <sub>g</sub> [HP]	Abtriebswelle Drehzahlen n <sub>2</sub> [r.p.m]	Abtriebswelle Drehmomente M <sub>2</sub> [Nm]	Übersetzung i	Zul.Querkräfte (Abtrieb) F <sub>qam</sub> [N]	Betriebsfaktor f <sub>s</sub>	Typ	Nennstrom [A]	Gewicht ~ [kg]	Maße Seite	Preis No.					
2,2 3,0	2.9	6672	311.14	61797	1.2	KR774-112M/6	5,1	386	158	KR128					
	3.2	5975	278.35	64946	1.3										
	3.5	5447	396.00	67094	1.5	KR774-100L/4a	5,1	375	158	KR129					
	4.0	4875	354.32	69412	1.6										
	4.5	4289	311.14	71470	1.9										
	5.0	3841	278.35	72940	2.1										
	5.8	3318	240.71	74563	2.4										
	6.7	2877	208.42	75853	2.8										
	7.7	2520	182.29	76924	3.2										
	3.9	4987	363.81	20298	0.9	KR674-100L/4a	5,1	272	146	KR130					
	4.4	4414	321.51	27260	1.0										
	5.1	3756	273.88	33105	1.1										
	6.0	3234	235.44	36863	1.3										
	6.9	2810	204.32	39478	1.5										
	7.0	2800	128.24	39572	1.5	KR673-112M/6	5,1	227	142	KR131					
	8.9	2204	100.90	42770	2.0										
	10	1973	90.21	43814	2.2										
	11	1806	128.24	44531	2.4	KR673-100L/4a	5,1	215	142	KR229					
	14	1422	100.90	46131	3.0										
	16	1273	90.21	46707	3.4										
	5.7	3373	246.42	13572	0.8	KR574-100L/4a	5,1	163	134	KR132					
	5.9	3254	237.97	15643	0.8										
	6.6	2895	211.51	20454	0.9										
	7.7	2478	180.90	24775	1.1										
	8.2	2389	109.86	25640	1.1	KR573-112M/6	5,1	158	130	KR133					
	9.3	2116	97.19	27777	1.3										
	11	1758	125.51	30269	1.5	KR573-100L/4a	5,1	148	130	KR134					
	13	1541	109.86	31595	1.8										
	15	1365	97.19	32524	2.0										
	17	1155	82.14	33531	2.3										
	21	948	67.37	34536	2.8										
	24	838	59.49	35013	3.2										
	13	1551	110.65	16830	1.0						KR473-100L/4a	5,1	103	118	KR135
	14	1372	97.79	18310	1.1										
16	1228	87.49	19362	1.3											
18	1080	76.83	20338	1.4											
22	903	64.17	21391	1.7											
23	854	60.63	21666	1.8											
24	832	59.19	21782	1.9											
27	721	51.22	22388	2.1											
31	629	44.64	22814	2.5											
36	552	39.11	23162	2.8											
47	427	30.11	23702	3.6											
	18	1097	78.29	7744	0.7	KR373-100L/4a	5,1	74	106	KR136					
	20	964	68.65	10182	0.9										
	23	853	60.69	11716	1.0										
	27	718	51.05	13236	1.1										

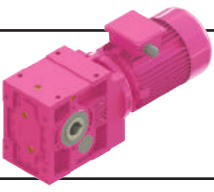

# K Serisi Motorlu Güç Devir Sayfaları

## K Series Geared Motors Performance Tables

### K Serien Getriebemotoren Leistung und Drehzahlübersicht

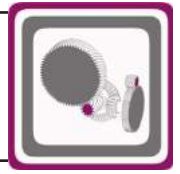

Güç	Çıkış Devri	Çıkış Momenti	Çevrim Oranı	Güv. Rad. Yük Çıkış	Servis Faktörü	Tipi	Anma Akımı	Ağırlık	Ölçü Sayfası	Fiyat Kodu					
Power	Output Speeds	Output Torque	Ratio	Per.O. Loads (Output)	Service Factors	Type	Rated Current	Weight	Dim. Page	Price Ref.					
Leistung P <sub>g</sub> [kW] P <sub>g</sub> [HP]	Abtriebswelle Drehzahlen n <sub>2</sub> [r.p.m]	Abtriebswelle Drehmomente M <sub>2</sub> [Nm]	Übersetzung i	Zul.Querkräfte (Abtrieb) F <sub>qam</sub> [N]	Betriebsfaktor f <sub>s</sub>	Typ	Nennstrom [A]	Gewicht ~ [kg]	Maße Seite	Preis No.					
2,2 3,0	32	611	43.40	14269	1.3	KR373-100L/4a	5,1	74	106	KR136					
	38	525	37.19	14983	1.6										
	42	475	33.65	15337	1.7										
	49	407	28.85	15848	2.0										
	57	349	24.72	16230	2.3										
	64	311	21.90	16477	2.6										
	75	265	18.62	16739	3.1										
	32	621	44.20	10738	0.7	KR273-100L/4a	5,1	38	98	KR137					
	38	515	36.55	11587	0.9										
	46	430	30.48	12188	1.0										
	55	361	25.55	12723	1.2										
	61	327	23.08	13008	1.3										
	73	271	19.08	13365	1.4										
	88	226	15.92	13627	1.6										
	105	190	13.34	13844	1.8										
	117	170	12.00	13507	1.5										
	141	141	9.92	12943	1.7										
	169	118	8.28	12403	2.0										
	202	99	6.94	11882	2.2										
	210	95	13.34	14058	3.2						KR273-90L/2	4,65	35	98	KR138
	233	85	12.00	13507	2.6										
282	71	9.92	12943	3.0											
338	59	8.28	12403	3.4											
404	49	6.94	11882	3.8											
64	312	22.06	3075	0,8	KR203-100L/4a	5,1	29	94	KR286						
92	219	15,26	3611	1,2	KR202-100L/4a	5,1	28	94	KR287						
98	205	14,32	3608	1,2											
115	174	12,17	3581	1,4											
132	152	10,57	3536	1,5											
151	133	9,25	3481	1,7											
183	110	7,65	3386	2,0											
220	92	6,38	3280	2,2											
262	77	5,35	3169	2,5											
303	66	9,25	3074	2,8	KR202-90L/2	4,65	25	94	KR288						
366	55	7,65	2944	3,2											
439	46	6,38	2817	3,6											
524	38	5,35	2693	4,0											
3,0 4,0	2.1	12352	673.01	90953	1.2	KR875-100L/4b	6,45	664	174	KR139					
	2.4	10725	584.66	97131	1.4										
	2.7	9934	339.70	99909	1.5	KR874-132S/6	6,9	685	170	KR140					
	3.2	8217	438.70	105388	1.8	KR874-100L/4b	6,45	645	170	KR141					
	3.7	7207	383.99	108332	2.1										
	4.1	6386	339.70	110569	2.3										
	4.9	5410	287.10	113067	2.8										
	6.0	4442	235.47	115440	3.4										
	6.8	3930	207.95	116560	3.8										
	7.6	3498	184.83	117485	4.0										
	2.9	9098	311.14	47811	0.9	KR774-132S/6	6,9	400	158	KR142					

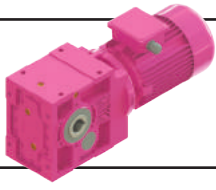

# K Serisi Motorlu Güç Devir Sayfaları

## K Series Geared Motors Performance Tables

### K Serien Getriebemotoren Leistung und Drehzahlübersicht



Güç	Çıkış Devri	Çıkış Momenti	Çevrim Oranı	Güv. Rad. Yük Çıkış	Servis Faktörü	Tipi	Anma Akımı	Ağırlık	Ölçü Sayfası	Fiyat Kodu	
Power	Output Speeds	Output Torque	Ratio	Per.O. Loads (Output)	Service Factors	Type	Rated Current	Weight	Dim. Page	Price Ref.	
Leistung P <sub>g</sub> [kW] P <sub>g</sub> [HP]	Abtriebswelle Drehzahlen n <sub>2</sub> [r.p.m]	Abtriebswelle Drehmomente M <sub>2</sub> [Nm]	Übersetzung i	Zul.Querkräfte (Abtrieb) F <sub>qam</sub> [N]	Betriebsfaktor f <sub>s</sub>	Typ	Nennstrom [A]	Gewicht ~ [kg]	Maße Seite	Preis No.	
3,0 4,0	3.2	8148	<b>278.35</b>	53872	1.0	<b>KR774-132S/6</b>	6,9	400	158	KR142	
	3.5	7428	<b>396.00</b>	57962	1.1	<b>KR774-100L/4b</b>	6,45	380	158	KR143	
	4.0	6648	<b>354.32</b>	61897	1.2						
	4.5	5849	<b>311.14</b>	65476	1.4						
	5.0	5238	<b>278.35</b>	67947	1.5						
	5.8	4524	<b>240.71</b>	70592	1.8						
	6.7	3924	<b>208.42</b>	72636	2.0						
	7.7	3437	<b>182.29</b>	74253	2.3						
	8.1	3330	<b>111.63</b>	74513	2.4	<b>KR773-132S/6</b>	6,9	382	154	KR144	
	9.1	2957	<b>99.00</b>	75617	2.7						
	10	2648	<b>88.57</b>	76488	3.0						
	12	2288	<b>76.59</b>	77512	3.5						
	5.1	5121	<b>273.88</b>	18223	18223	0.8	<b>KR674-100L/4b</b>	6,45	275	146	KR145
	6.0	4409	<b>235.44</b>	27179	27179	1.0					
	6.9	3832	<b>204.32</b>	32506	32506	1.1					
	7.0	3815	<b>128.24</b>	32717	32717	1.1	<b>KR673-132S/6</b>	6,9	232	142	KR146
	8.9	3003	<b>100.90</b>	38324	38324	1.4					
	10	2688	<b>90.21</b>	40196	40196	1.6					
	11	2464-	<b>128.24</b>	41421	41421	1.7	<b>KR673-100L/4b</b>	6,45	217	142	KR230
	14	1940	<b>100.90</b>	43864	43864	2.2					
16	1736	<b>90.21</b>	44832	44832	2.5						
17	1549	<b>80.38</b>	45620	45620	2.8						
7.7	3379	<b>180.90</b>	13438	13438	0.8	<b>KR574-100L/4b</b>	6,45	166	134	KR147	
9.3	2883	<b>97.19</b>	20736	20736	0.9	<b>KR574-132S/6</b>	6,9	178	134	KR148	
11	2399	<b>125.51</b>	25717	25717	1.1	<b>KR573-100L/4b</b>	6,45	151	130	KR149	
13	2102	<b>109.86</b>	27992	27992	1.3						
14	1862	<b>97.19</b>	29610	29610	1.5						
17	1576	<b>82.14</b>	31337	31337	1.7						
21	1293	<b>67.37</b>	32874	32874	2.1						
24	1143	<b>59.49</b>	33619	33619	2.4						
27	1017	<b>52.88</b>	34244	34244	2.7						
29	931	<b>97.19</b>	34621	34621	2.9	<b>KR573-100L/2</b>	6,0	149	130	KR150	
34	788	<b>82.14</b>	35608	35608	3.3						
14	1873	<b>97.79</b>	13340	13340	0.8	<b>KR473-100L/4b</b>	6,45	107	118	KR151	
16	1675	<b>87.49</b>	15567	15567	0.9						
18	1473	<b>76.83</b>	17437	17437	1.1						
22	1232	<b>64.17</b>	19260	19260	1.3						
23	1165	<b>60.63</b>	19785	19785	1.3						
24	1136	<b>59.19</b>	19957	19957	1.4						
27	984	<b>51.22</b>	20938	20938	1.6						
31	859	<b>44.64</b>	21638	21638	1.8						
36	753	<b>39.11</b>	22191	22191	2.1						
56	488	<b>25.15</b>	23442	23442	3.2						

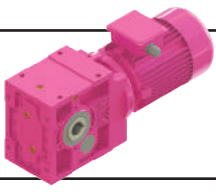

# K Serisi Motorlu Güç Devir Sayfaları

## K Series Geared Motors Performance Tables

### K Serien Getriebemotoren Leistung und Drehzahlübersicht

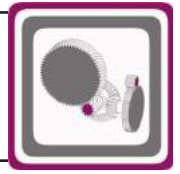

Güç	Çıkış Devri	Çıkış Momenti	Çevrim Oranı	Güv. Rad. Yük Çıkış	Servis Faktörü	Tipi	Anma Akımı	Ağırlık	Ölçü Sayfası	Fiyat Kodu					
Power	Output Speeds	Output Torque	Ratio	Per.O. Loads (Output)	Service Factors	Type	Rated Current	Weight	Dim. Page	Price Ref.					
Leistung P <sub>g</sub> [kW] P <sub>g</sub> [HP]	Abtriebswelle Drehzahlen n <sub>2</sub> [r.p.m]	Abtriebswelle Drehmomente M <sub>2</sub> [Nm]	Übersetzung i	Zul.Querkräfte (Abtrieb) F <sub>qam</sub> [N]	Betriebsfaktor f <sub>s</sub>	Typ	Nennstrom [A]	Gewicht ~ [kg]	Maße Seite	Preis No.					
3,0 4,0	27	980	51.05	9894	0.8	KR373-100L/4b	6,45	77	106	KR152					
	32	834	43.40	11945	1.0										
	38	716	37.19	13261	1.1										
	42	648	33.65	13915	1.3										
	49	555	28.85	14728	1.5										
	57	476	24.72	15349	1.7										
	64	425	21.90	15732	1.9										
	75	362	18.62	16147	2.3										
	88	311	15.96	16473	2.6										
	97	281	14.44	16646	2.9										
	46	586	30.48	11059	0.8						KR273-100L/4b	6,45	42	98	KR153
	55	492	25.55	11907	0.9										
	61	446	23.08	12336	0.9										
	73	369	19.08	12892	1.1										
88	309	15.92	13286	1.2											
105	259	13.34	13513	1.4											
117	232	12.00	12939	1.1											
141	192	9.92	12473	1.2											
169	161	8.28	12011	1.4											
202	135	6.94	11554	1.6											
210	130	13.34	13513	2.3	KR273-100L/2	6,0	38	98	KR154						
233	116	12.00	12939	1.9											
282	96	9.92	12473	2.2											
338	80	8.28	12011	2.5											
404	67	6.94	11554	2.8											
92	298	15,26	2944	0,9	KR202-100L/4b	6,45	32	94	KR289						
98	280	14,32	2984	0,9											
115	238	12,17	3055	1,0											
132	207	10,57	3083	1,1											
151	181	9,25	3086	1,3											
183	150	7,65	3061	1,4											
220	125	6,38	3011	1,6											
262	105	5,35	2944	1,9											
303	91	9,25	2883	2,0						KR202-100L/2	6,0	29	94	KR290	
366	75	7,65	2786	2,3											
439	63	6,38	2685	2,6											
524	53	5,35	2583	3,0											
4,0 5,5	2.7	12586	514.05	89993	1.2	KR875-112M/4	8,2	670	174	KR155					
	3.0	11366	463.83	94758	1.3										
	3.6	9609	383.99	101005	1.6	KR874-112M/4	8,2	654	170	KR156					
	4.1	8515	339.70	104504	1.8										
	4.9	7213	287.10	108474	2.1										
	5.9	5923	235.47	111834	2.5										
	6.7	5240	207.95	113509	2.9										
	7,7	4622	115,87	114819	3,2	KR873-132M/6a	9,0	650	166	KR233					
	8,7	4123	103,24	116096	3,6										
	9,7	3710	92,80	117008	4,0										
	3.5	9904	396.00	41117	0.8	KR774-112M/4	8,2	387	158	KR157					
	4.0	8864	354.32	49280	0.9										
	4.5	7798	311.14	55914	1.0										

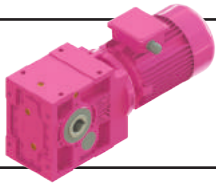

# K Serisi Motorlu Güç Devir Sayfaları

## K Series Geared Motors Performance Tables

### K Serien Getriebemotoren Leistung und Drehzahlübersicht



Güç	Çıkış Devri	Çıkış Momenti	Çevrim Oranı	Güv. Rad. Yük Çıkış	Servis Faktörü	Tipi	Anma Akımı	Ağırlık	Ölçü Sayfası	Fiyat Kodu
Power	Output Speeds	Output Torque	Ratio	Per.O. Loads (Output)	Service Factors	Type	Rated Current	Weight	Dim. Page	Price Ref.
Leistung P <sub>g</sub> [kW] P <sub>g</sub> [HP]	Abtriebswelle Drehzahlen n <sub>2</sub> [r.p.m]	Abtriebswelle Drehmomente M <sub>2</sub> [Nm]	Übersetzung i	Zul.Querkräfte (Abtrieb) F <sub>qam</sub> [N]	Betriebsfaktor f <sub>s</sub>	Typ	Nennstrom [A]	Gewicht ~ [kg]	Maße Seite	Preis No.
4,0 5,5	5.0	6984	<b>278.35</b>	60237	1.1	<b>KR774-112M/4</b>	8,2	387	158	KR157
	5.8	6032	<b>240.71</b>	64660	1.3					
	6.7	5232	<b>208.42</b>	67951	1.5					
	7.7	4582	<b>182.29</b>	70443	1.7					
8.1	8.1	4445	<b>111.63</b>	70973	1.8	<b>KR773-132M/6a</b>	9,0	401	154	KR158
	9.1	3946	<b>99.00</b>	72563	2.0					
	10	3534	<b>88.57</b>	73876	2.3					
	12	3054	<b>76.59</b>	75378	2.6					
	14	2648	<b>66.32</b>	76492	3.0					
	16	2319	<b>58.00</b>	77404	3.4					
7.0	7.0	5091	<b>128.24</b>	19073	0.8	<b>KR673-132M/6a</b>	9,0	232	142	KR159
	8.9	4008	<b>100.90</b>	31129	1.1					
	10.0	3587	<b>90.21</b>	34457	1.2					
11	11	3286	<b>128.24</b>	36660	1.3	<b>KR673-112M/4</b>	8,2	227	142	KR160
	14	2588	<b>100.90</b>	40811	1.7					
	16	2316	<b>90.21</b>	42194	1.9					
	17	2066	<b>80.38</b>	43322	2.1					
13	13	2804	<b>109.86</b>	21813	1.0	<b>KR573-112M/4</b>	8,2	158	130	KR161
	14	2484	<b>97.19</b>	24908	1.1					
	17	2102	<b>82.14</b>	27930	1.3					
	21	1725	<b>67.37</b>	30497	1.6					
	24	1525	<b>59.49</b>	31617	1.8					
	26	1357	<b>52.88</b>	32561	2.0					
	31	1150	<b>44.73</b>	33973	2.3					
	37	982	<b>38.16</b>	35260	2.5					
42	42	864	<b>67.37</b>	35960	2.8	<b>KR573-112M/2</b>	7,8	154	130	KR162
	47	764	<b>59.49</b>	36700	3.1					
22	22	1644	<b>64.17</b>	15837	0.9	<b>KR473-112M/4</b>	8,2	114	118	KR163
	23	1554	<b>60.63</b>	16692	1.0					
	24	1515	<b>59.19</b>	17042	1.0					
	27	1313	<b>51.22</b>	18715	1.2					
	31	1146	<b>44.64</b>	19888	1.4					
	36	1005	<b>39.11</b>	20778	1.5					
	46	778	<b>30.11</b>	22058	2.0					
	56	651	<b>25.15</b>	22805	2.4					
	59	615	<b>23.76</b>	22529	2.5					
	60	600	<b>23.19</b>	22412	2.6					
	70	520	<b>20.07</b>	21705	2.9					
	80	454	<b>17.49</b>	21029	3.1					
	32	32	1113	<b>43.40</b>	7361					
38		955	<b>37.19</b>	10281	0.9					
42		865	<b>33.65</b>	11543	0.9					
49		741	<b>28.85</b>	12988	1.1					
57		636	<b>24.72</b>	14054	1.3					
64		567	<b>21.90</b>	14639	1.4					
75		483	<b>18.62</b>	15299	1.7					
88		414	<b>15.96</b>	15789	2.0					
97		375	<b>14.44</b>	16059	2.2					
113		322	<b>12.38</b>	16395	2.5					
132		276	<b>10.60</b>	16295	2.9					

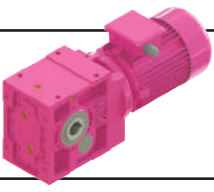

# K Serisi Motorlu Güç Devir Sayfaları

## K Series Geared Motors Performance Tables

### K Serien Getriebemotoren Leistung und Drehzahlübersicht

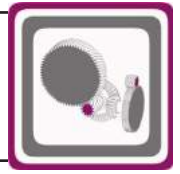

Güç	Çıkış Devri	Çıkış Momenti	Çevrim Oranı	Güv. Rad. Yük Çıkış	Servis Faktörü	Tipi	Anma Akımı	Ağırlık	Ölçü Sayfası	Fiyat Kodu					
Power	Output Speeds	Output Torque	Ratio	Per.O. Loads (Output)	Service Factors	Type	Rated Current	Weight	Dim. Page	Price Ref.					
Leistung P <sub>g</sub> [kW] P <sub>g</sub> [HP]	Abtriebswelle Drehzahlen n <sub>2</sub> [r.p.m]	Abtriebswelle Drehmomente M <sub>2</sub> [Nm]	Übersetzung i	Zul.Querkräfte (Abtrieb) F <sub>qam</sub> [N]	Betriebsfaktor f <sub>s</sub>	Typ	Nennstrom [A]	Gewicht ~ [kg]	Maße Seite	Preis No.					
4,0 5,5	61	595	23.08	11305	0.7	KR273-112M/4	8,2	49	98	KR165					
	73	493	19.08	12169	0.8										
	88	412	15.92	12773	0.9										
	105	346	13.34	12831	1.0										
	117	310	12.00	12228	0.8										
	141	256	9.92	11885	0.9										
	169	214	8.28	11521	1.1										
	202	180	6.94	11143	1.2										
	210	173	13.34	12831	1.7	KR273-112M/2	7,8	44	98	KR166					
	233	155	12.00	12228	1.4										
	282	129	9.92	11885	1.6										
	338	107	8.28	11521	1.9										
	404	90	6.94	11143	2.1										
	132	276	10,57	2501	0,9	KR202-112M/4	8,2	38	94	KR291					
	151	242	9,25	2581	1,0										
	183	200	7,65	2647	1,1										
	220	167	6,38	2669	1,2										
	262	140	5,35	2659	1,4										
	303	121	9,25	2637	1,5	KR202-112M/2	7,8	34	94	KR292					
	366	100	7,65	2584	1,7										
	439	84	6,38	2518	2,0										
	524	70	5,35	2443	2,2										
	5.5 7.5	4.1	11708	339.70	93538	1.3	KR874-132S/4	11,3	643	170	KR167				
		4.9	9918	287.10	100050	1.5									
		5.9	8144	235.47	105670	1.8									
		6.7	7205	207.95	108370	2.1									
		7.8	6360	115.87	110541	2.4	KR873-132M/6b	12,3	645	166	KR231				
		8.7	5673	103.24	112371	2.6									
9.7		5105	92.80	113801	2.9										
11		4456	81.06	115346	3.4										
5.0		9603	278.35	43675	0.8	KR774-132S/4	15,3	412	158	KR168					
5.8		8295	240.71	53122	1.0										
6.7		7194	208.42	59303	1.1										
7.7		6301	182.29	63537	1.3										
8.1		6116	111.63	64329	1.3	KR773-132M/6b	12,3	400	154	KR169					
9.1		5431	99.00	67180	1.5										
10		4863	88.57	69355	1.6										
12		4202	76.59	71755	1.9										
13		3946	111.63	72628	2.0	KR773-132S/4	11,3	382	154	KR170					
14		3504	99.00	74025	2.3										
16		3138	88.57	75182	2.5										
18		2712	76.59	76358	2.9										
21		2352	66.32	77301	3.4	10	4936	90.21	21007	0.9	KR673-132M/6b	12,3	232	142	KR171
11		4519	128.24	26442	1.0										
14		3558	100.90	34778	1.2										

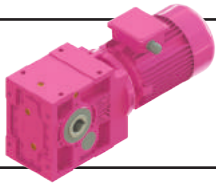

# K Serisi Motorlu Güç Devir Sayfaları

## K Series Geared Motors Performance Tables

### K Serien Getriebemotoren Leistung und Drehzahlübersicht



Güç	Çıkış Devri	Çıkış Momenti	Çevrim Oranı	Güv. Rad. Yük Çıkış	Servis Faktörü	Tipi	Anma Akımı	Ağırlık	Ölçü Sayfası	Fiyat Kodu
Power	Output Speeds	Output Torque	Ratio	Per.O. Loads (Output)	Service Factors	Type	Rated Current	Weight	Dim. Page	Price Ref.
Leistung P <sub>g</sub> [kW] P <sub>g</sub> [HP]	Abtriebswelle Drehzahlen n <sub>2</sub> [r.p.m]	Abtriebswelle Drehmomente M <sub>2</sub> [Nm]	Übersetzung i	Zul.Querkräfte (Abtrieb) F <sub>qam</sub> [N]	Betriebsfaktor f <sub>s</sub>	Typ	Nennstrom [A]	Gewicht ~ [kg]	Maße Seite	Preis No.
5.5 7.5	16	3185	90.21	37287	1.4	KR673-132S/4	11,3	232	142	KR172
	17	2841	80.38	39360	1.5					
	20	2419	68.47	41659	1.8					
	24	2083	58.86	43360	2.1					
	27	1810	51.08	44559	2.4					
	31	1584	44.65	45501	2.7					
	14	3415	97.19	13241	0.8	KR573-132S/4	11,3	163	130	KR173
	17	2891	82.14	20804	0.9					
	21	2372	67.37	25809	1.1					
	24	2097	59.49	27974	1.3					
	26	1866	52.88	29553	1.4					
	31	1581	44.73	31750	1.7					
	37	1350	38.16	33588	1.9					
	40	1249	35.34	34340	1.9					
	46	1071	30.25	35323	2.1					
	54	919	25.78	34181	2.5					
	62	813	22.77	33277	2.7					
	27	1805	51.22	14043	0.9	KR473-132S/4	11,3	121	118	KR174
	31	1576	44.64	16466	1.0					
	36	1382	39.11	18136	1.1					
	46	1070	30.11	20362	1.4					
	56	895	25.15	21410	1.7					
	59	846	23.76	21514	1.8					
	60	825	23.19	21421	1.9					
	70	715	20.07	20847	2.1					
	80	624	17.49	20281	2.3					
	91	548	15.33	19726	2.5					
	102	489	13.71	18654	2.1					
	118	424	11.87	18116	2.3					
	135	370	10.34	17593	2.5					
154	324	9.06	17085	2.8						
187	268	7.48	16347	3.2						
49	1019	28.85	9205	0.8	KR373-132S/4	11,3	86	106	KR175	
57	874	24.72	11379	0.9						
64	780	21.90	12560	1.1						
75	664	18.62	13755	1.2						
88	570	15.96	14577	1.4						
97	516	14.44	15039	1.6						
113	442	12.38	15586	1.9						
132	379	10.60	15679	2.1						
140	356	9.97	15125	1.8						
164	306	8.54	14683	2.1						
181	277	7.73	14389	2.2						
211	237	6.63	13927	2.5						
247	204	5.68	13456	2.8						
7.5 10	4.9	13525	287.10	85808						1.1
	6.0	11106	235.47	95759	1.4					
	6.7	9825	207.95	100298	1.5					
	7.6	8746	184.83	103797	1.7					
	8.7	7648	161.34	107224	2.0					
	9.9	6757	142.32	109621	2.2					
	7.8	8675	115.87	104040	1.7	KR873-160M/6	15,2	725	166	KR178
	8.7	7738	103.24	106688	1.9					
	9.7	6963	92.80	109012	2.2					
	11	6078	81.06	111369	2.5					

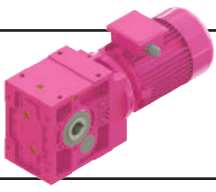

# K Serisi Motorlu Güç Devir Sayfaları

## K Series Geared Motors Performance Tables

### K Serien Getriebemotoren Leistung und Drehzahlübersicht

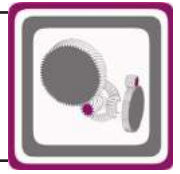

Güç	Çıkış Devri	Çıkış Momenti	Çevrim Oranı	Güv. Rad. Yük Çıkış	Servis Faktörü	Tipi	Anma Akımı	Ağırlık	Ölçü Sayfası	Fiyat Kodu
Power	Output Speeds	Output Torque	Ratio	Per.O. Loads (Output)	Service Factors	Type	Rated Current	Weight	Dim. Page	Price Ref.
Leistung P <sub>g</sub> [kW] P <sub>g</sub> [HP]	Abtriebswelle Drehzahlen n <sub>2</sub> [r.p.m]	Abtriebswelle Drehmomente M <sub>2</sub> [Nm]	Übersetzung i	Zul.Querkräfte (Abtrieb) F <sub>qam</sub> [N]	Betriebsfaktor f <sub>s</sub>	Typ	Nennstrom [A]	Gewicht ~ [kg]	Maße Seite	Preis No.
7.5 10	13	5313	70.76	113407	2.8	KR873-160M/6	15,2	725	166	KR178
	14	4693	62.42	114803	3.2					
	12	5598	115.87	112586	2.7	KR873-132M/4	15,3	665	166	KR232
	14	4994	103.24	114025	3.0					
	15	4494	92.80	115152	3.3					
	17	3923	81.06	116543	3.8					
	8.0	8342	111.63	52779	1.0	KR773-160M/6	15,2	460	154	KR179
	9.1	7407	99.00	58094	1.1					
	10	6633	88.57	61977	1.2					
	12	5732	76.59	66002	1.4					
	13	5383	111.63	67469	1.5	KR773-132M/4	15,3	400	154	KR180
	14	4780	99.00	69839	1.7					
	16	4281	88.57	71539	1.9					
	18	3699	76.59	73414	2.2					
	21	3208	66.32	74953	2.5					
	24	2810	58.00	76073	2.8					
	27	2480	51.13	76937	3.2					
	14	4854	100.90	22556	0.9					
16	4344	90.21	28184	1.0						
17	3876	80.38	32322	1.1						
20	3299	68.47	36485	1.3						
24	2841	58.86	39388	1.5						
27	2469	51.08	41402	1.7						
31	2161	44.65	42928	2.0						
43	1589	32.68	45421	2.7						
50	1368	28.10	46361	3.1						
	21	3236	67.37	16282	0.8	KR573-132M/4	15,3	180	130	KR182
	24	2861	59.49	21103	0.9					
	27	2546	52.88	24270	1.1					
	31	2157	44.73	28085	1.2					
	37	1842	38.16	30935	1.4					
	40	1704	35.34	32073	1.4					
	46	1461	30.25	33479	1.6					
	54	1253	25.78	32609	1.8					
	62	1108	22.77	31889	2.0					
	69	986	20.24	31179	2.1					
	75	915	18.80	30724	2.2					
	88	775	15.88	29664	2.5					
	104	661	13.53	28636	2.8					
	121	566	11.58	27636	3.0					
	36	1885	39.11	13067	0.8	KR473-132M/4	15,3	138	118	KR183
	46	1459	30.11	17453	1.1					
	56	1221	25.15	19321	1.3					
	59	1154	23.76	19794	1.3					
	60	1126	23.19	19989	1.4					
	70	976	20.07	19703	1.5					
	80	852	17.49	19284	1.7					
	91	747	15.33	18852	1.8					
	102	667	13.71	17655	1.5					
	118	578	11.87	17251	1.7					
	135	504	10.34	16840	1.9					
	154	443	9.06	16425	2.0					
	187	366	7.48	15802	2.4					
	225	304	6.21	15179	2.7					

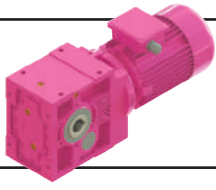

# K Serisi Motorlu Güç Devir Sayfaları

## K Series Geared Motors Performance Tables

### K Serien Getriebemotoren Leistung und Drehzahlübersicht



Güç	Çıkış Devri	Çıkış Momenti	Çevrim Oranı	Güv. Rad. Yük Çıkış	Servis Faktörü	Tipi	Anma Akımı	Ağırlık	Ölçü Sayfası	Fiyat Kodu	
Power	Output Speeds	Output Torque	Ratio	Per.O. Loads (Output)	Service Factors	Type	Rated Current	Weight	Dim. Page	Price Ref.	
Leistung P <sub>g</sub> [kW] P <sub>g</sub> [HP]	Abtriebswelle Drehzahlen n <sub>2</sub> [r.p.m]	Abtriebswelle Drehmomente M <sub>2</sub> [Nm]	Übersetzung i	Zul.Querkräfte (Abtrieb) F <sub>qam</sub> [N]	Betriebsfaktor f <sub>s</sub>	Typ	Nennstrom [A]	Gewicht ~ [kg]	Maße Seite	Preis No.	
7.5 10	236	290	11.87	17251	2.7	KR473-132S/2b	14,6	121	118	KR184	
	271	253	10.34	16840	3.0						
	309	222	9.06	16425	3.3						
	64	1064	21.90	8360	0.8	KR373-132M/4	15,3	105	106	KR185	
		75	906	18.62	10966						0.9
		88	777	15.96	12574						1.1
		97	704	14.44	13340						1.2
		113	603	12.38	14293						1.4
		132	518	10.60	14854						1.6
		140	486	9.97	14220						1.3
		164	417	8.54	13909						1.5
		181	378	7.73	13689						1.6
		211	324	6.63	13328						1.8
		247	278	5.68	12943						2.1
		11 15	264	259	10.60						14854
281	244		9.97	14220	2.2						
328	209		8.54	13909	2.4						
362	189		7.73	13689	2.6						
423	162		6.63	13328	3.0						
7.6	12828		184.83	88871	1.2	KR874-160M/4	21,5	746	170	KR187	
	8.7		11217	161.34	95464						1.3
	9.8		9910	142.32	100048						1.5
7.8	12730		115.87	89385	1.2	KR873-160L/6	22	746	166	KR188	
	8.7		11356	103.24	94825						1.3
	9.7		10218	92.80	98922						1.5
	11		8919	81.06	103233						1.7
12	8213		115.87	105498	1.8	KR873-160M/4	21,5	725	166	KR189	
	14		7327	103.24	108095						2.0
	15		6593	92.80	110090						2.3
	17	5756	81.06	112392	2.6						
	20	5032	70.76	114064	3.0						
	22	4445	62.42	115398	3.4						
	10	9735	88.57	42764	0.8						KR773-160L/6
12		8412	76.59	52182	1.0						
13	7897	111.63	55500	1.0	KR773-160M/4	21,5	460	154	KR191		
	14	7012	99.00	60322						1.1	
	16	6280	88.57	63717						1.3	
	18	5427	76.59	67275						1.5	
	21	4707	66.32	69977						1.7	
	24	4123	58.00	72021						1.9	
	27	3639	51.13	73568						2.2	
	31	3232	45.36	73881						2.5	
	35	2885	40.44	72236						2.8	
	36	2780	39.00	71706						2.9	
	41	2411	33.78	69585						3.3	
20	4840	68.47	22665	0.9	KR673-160M/4	21,5	306	142	KR192		
	24	4168	58.86	29790						1.0	
	27	3622	51.08	34245						1.2	
	31	3171	44.65	37332						1.4	

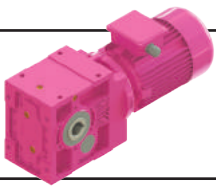

# K Serisi Motorlu Güç Devir Sayfaları

## K Series Geared Motors Performance Tables

### K Serien Getriebemotoren Leistung und Drehzahlübersicht

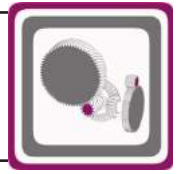

Güç	Çıkış Devri	Çıkış Momenti	Çevrim Oranı	Güv. Rad. Yük Çıkış	Servis Faktörü	Tipi	Anma Akımı	Ağırlık	Ölçü Sayfası	Fiyat Kodu						
Power	Output Speeds	Output Torque	Ratio	Per.O. Loads (Output)	Service Factors	Type	Rated Current	Weight	Dim. Page	Price Ref.						
Leistung P <sub>g</sub> [kW] P <sub>g</sub> [HP]	Abtriebswelle Drehzahlen n <sub>2</sub> [r.p.m]	Abtriebswelle Drehmomente M <sub>2</sub> [Nm]	Übersetzung i	Zul.Querkräfte (Abtrieb) F <sub>qam</sub> [N]	Betriebsfaktor f <sub>s</sub>	Typ	Nennstrom [A]	Gewicht ~ [kg]	Maße Seite	Preis No.						
11 15	36	2791	39.26	39583	1.5	KR673-160M/4	21,5	306	142	KR192						
	43	2331	32.68	42035	1.8											
	50	2008	28.10	43626	2.1											
	57	1745	24.38	42628	2.5											
	66	1528	21.32	41620	2.8											
	75	1345	18.74	40611	3.2											
	31	3164	44.73	18368	0.8	KR573-160M/4	21,5	241	130	KR193						
		37	2703	38.16	24612						0.9					
		40	2500	35.34	26928						1.0					
		46	2143	30.25	30251						1.1					
		54	1839	25.78	29858						1.3					
		62	1626	22.77	29459						1.4					
		69	1447	20.24	29020						1.5					
		75	1342	18.80	28718						1.5					
		88	1136	15.88	27970						1.7					
		104	969	13.53	27193						1.9					
		121	831	11.58	26400						2.0					
		125	802	11.22	25849						1.8					
		148	679	9.48	25015						2.0					
		173	579	8.07	24193						2.2					
		203	497	6.91	23384						2.5					
	60	1651	23.19	15670	0.9	KR473-160M/4	21,5	198	118	KR194						
		70	1432	20.07	17700						1.0					
		80	1250	17.49	17539						1.1					
		91	1096	15.33	17323						1.2					
		102	978	13.71	15907						1.0					
		118	848	11.87	15738						1.1					
		135	740	10.34	15521						1.3					
		155	649	9.06	15270						1.4					
		187	537	7.48	14848						1.6					
225		447	6.21	14387	1.9											
15 20		8.7	15487	103.24	76049						1.0	KR873-180L/6	29	769	166	KR195
		9.7	13936	92.80	83893						1.1					
		11	12165	81.06	91406						1.2					
		12	11201	115.87	95567						1.3	KR873-160L/4	29	746	166	KR196
			14	9993	103.24						99993					
	15		8993	92.80	103117	1.7										
	17		7850	81.06	106695	1.9										
	20		6864	70.76	109386	2.2										
	22		6063	62.42	111466	2.5										
	25		5401	55.53	113164	2.8										
	28		4844	49.75	114473	3.1										
	14		9564	99.00	44581	0.8	KR773-160L/4	29	481	154	KR197					
			16	8566	88.57	51538										
		18	7402	76.59	58258	1.1										
		21	6420	66.32	62973	1.2										
		24	5623	58.00	66466	1.4										
		27	4963	51.13	69022	1.6										
		31	4409	45.36	69715	1.8										
		35	3935	40.44	68522	2.0										
		36	3792	39.00	68124	2.1										
		41	3289	33.78	66482	2.4										
		48	2866	29.40	64802	2.8										
		53	2590	26.52	63510	3.1										
		60	2301	23.52	61978	3.5										

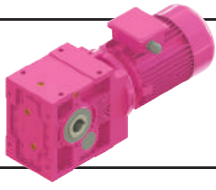

# K Serisi Motorlu Güç Devir Sayfaları

## K Series Geared Motors Performance Tables

### K Serien Getriebemotoren Leistung und Drehzahlübersicht



Güç	Çıkış Devri	Çıkış Momenti	Çevrim Oranı	Güv. Rad. Yük Çıkış	Servis Faktörü	Tipi	Anma Akımı	Ağırlık	Ölçü Sayfası	Fiyat Kodu							
Power	Output Speeds	Output Torque	Ratio	Per.O. Loads (Output)	Service Factors	Type	Rated Current	Weight	Dim. Page	Price Ref.							
Leistung P <sub>g</sub> [kW] P <sub>g</sub> [HP]	Abtriebswelle Drehzahlen n <sub>2</sub> [r.p.m]	Abtriebswelle Drehmomente M <sub>2</sub> [Nm]	Übersetzung i	Zul.Querkräfte (Abtrieb) F <sub>qam</sub> [N]	Betriebsfaktor f <sub>s</sub>	Typ	Nennstrom [A]	Gewicht ~ [kg]	Maße Seite	Preis No.							
15 20	27	4940	51.08	21269	0.9	KR673-160L/4	29	343	142	KR198							
	31	4324	44.65	28276	1.0												
	36	3806	39.26	32748	1.1												
	43	3179	32.68	37199	1.4												
	50	2738	28.10	39935	1.6												
	57	2380	24.38	39775	1.8												
	66	2084	21.32	39126	2.1												
	75	1834	18.74	38419	2.3												
	85	1622	16.54	37671	2.7												
	97	1414	14.49	36425	2.1												
	112	1218	12.46	35458	2.3												
	130	1059	10.81	34507	2.6												
	148	927	9.45	33577	2.8												
	169	816	8.31	32670	3.1												
	15 20	54	2508	25.78	26714						0.9	KR573-160L/4	29	261	130	KR199	
		62	2218	22.77	26683						1.0						
		69	1974	20.24	26552						1.1						
		74	1831	18.80	26426						1.1						
88		1550	15.88	26033	1.2												
104		1322	13.53	25544	1.4												
121		1134	11.58	24988	1.5												
125		1094	11.22	24339	1.3												
148		926	9.48	23739	1.5												
173		790	8.07	23107	1.6												
203		678	6.91	22454	1.8												
15 20		80	1704	17.49	15545	0.8	KR473-160L/4	29	220	118	KR200						
		91	1495	15.33	15576	0.9											
		102	1334	13.71	13909	0.8											
	118	1157	11.87	14009	0.8												
	135	1010	10.34	14014	0.9												
	154	886	9.06	13949	1.0												
	187	733	7.48	13757	1.2												
	225	610	6.21	13482	1.4												
	18.5 25	12	13317	113.42	86740	1.1						KR874-180M/4	36	794	170	KR201	
		14	11571	98.53	94026	1.3											
		18.5 25	11	15001	81.06	78573						1.0	KR873-200L/6a	36	787	166	KR202
			13	13115	70.76	87503						1.1					
		18.5 25	14	12325	103.24	91172						1.2	KR873-180M/4	36	777	166	KR203
			15	11092	92.80	95940						1.4					
17			9683	81.06	100974	1.5											
20			8466	70.76	104770	1.8											
22			7479	62.42	107639	2.0											
25			6662	55.53	109915	2.3											
28			5975	49.75	111691	2.5											
32			5192	43.22	114214	2.8											
37			4571	38.00	113404	3.1											
18.5 25			18	9130	76.59	47707	0.9	KR773-180M/4	36	510	154	KR204					
		21	7919	66.32	55288	1.0											
		24	6936	58.00	60593	1.2											
		27	6122	51.13	64329	1.3											
		31	5438	45.36	66070	1.5											
	35	4854	40.44	65271	1.6												
	36	4677	39.00	64990	1.7												

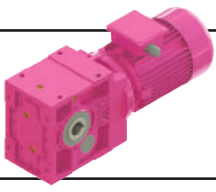

# K Serisi Motorlu Güç Devir Sayfaları

## K Series Geared Motors Performance Tables

### K Serien Getriebemotoren Leistung und Drehzahlübersicht

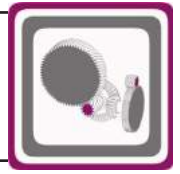

Güç	Çıkış Devri	Çıkış Momenti	Çevrim Oranı	Güv. Rad. Yük Çıkış	Servis Faktörü	Tipi	Anma Akımı	Ağırlık	Ölçü Sayfası	Fiyat Kodu						
Power	Output Speeds	Output Torque	Ratio	Per.O. Loads (Output)	Service Factors	Type	Rated Current	Weight	Dim. Page	Price Ref.						
Leistung P <sub>g</sub> [kW] P <sub>g</sub> [HP]	Abtriebswelle Drehzahlen n <sub>2</sub> [r.p.m]	Abtriebswelle Drehmomente M <sub>2</sub> [Nm]	Übersetzung i	Zul.Querkräfte (Abtrieb) F <sub>qam</sub> [N]	Betriebsfaktor f <sub>s</sub>	Typ	Nennstrom [A]	Gewicht ~ [kg]	Maße Seite	Preis No.						
18.5 25	41	4057	33.78	63767	2.0	KR773-180M/4	36	510	154	KR204						
	48	3535	29.40	62439	2.3											
	53	3195	26.52	61379	2.5											
	60	2838	23.52	60087	2.8											
	67	2534	20.97	58800	3.2											
	69	2441	20.23	58383	3.2											
	31	31	5334	44.65	14592	0.8	KR673-180M/4	36	372	142	KR205					
		36	4695	39.26	24378	0.9										
		43	3922	32.68	31859	1.1										
		50	3377	28.10	35929	1.3										
		57	2936	24.38	37279	1.5										
		66	2570	21.32	36944	1.7										
		75	2263	18.74	36500	1.9										
		85	2000	16.54	35977	2.1										
		97	1744	14.49	34850	1.7										
112		1502	12.46	34104	1.9											
130		1306	10.81	33332	2.1											
148		1143	9.45	32550	2.3											
169		1007	8.31	31766	2.5											
62		62	2736	22.77	24253	0.8						KR573-180M/4	36	294	130	KR206
		69	2435	20.24	24392	0.9										
	75	2258	18.80	24420	0.9											
	88	1912	15.88	24338	1.0											
	104	1631	13.53	24101	1.1											
	121	1399	11.58	23753	1.2											
	125	1350	11.22	23019	1.1											
	148	1143	9.48	22623	1.2											
	173	975	8.07	22156	1.3											
	203	836	6.91	21641	1.5											
	155	155	1093	9.06	12794	0.8	KR473-180M/4	36	252	118	KR207					
		187	904	7.48	12803	1.0										
		225	752	6.21	12690	1.1										
	22 30	11	17843	81.06	61164	0.8	KR873-200L/6b	43	807	166	KR208					
		13	15599	70.76	75326	1.0										
14	14	14658	103.24	80674	1.0	KR873-180L/4	36	817	166	KR209						
	15	13191	92.80	87445	1.1											
	17	11515	81.06	94430	1.3											
	20	10068	70.76	99593	1.5											
	22	8894	62.42	103409	1.7											
	25	7923	55.53	106246	1.9											
	28	7106	49.75	108679	2.1											
	32	6175	43.22	111799	2.4											
	37	5436	38.00	111045	2.6											
	41	4911	34.28	108671	2.8											
	21	21	9417	66.32	45602						0.8	KR773-180L/4	36	551	154	KR210
		24	8248	58.00	53423						1.0					
		27	7281	51.13	58806						1.1					
		31	6467	45.36	62424						1.2					
		35	5773	40.44	62021						1.4					
36		5562	39.00	61856	1.4											
41		4825	33.78	61052	1.7											
48		4205	29.40	60077	1.9											
53		3800	26.52	59249	2.1											
60		3375	23.52	58197	2.4											

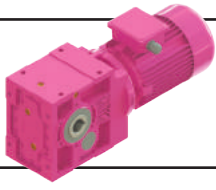

# K Serisi Motorlu Güç Devir Sayfaları

## K Series Geared Motors Performance Tables

### K Serien Getriebemotoren Leistung und Drehzahlübersicht



Güç	Çıkış Devri	Çıkış Momenti	Çevrim Oranı	Güv. Rad. Yük Çıkış	Servis Faktörü	Tipi	Anma Akımı	Ağırlık	Ölçü Sayfası	Fiyat Kodu						
Power	Output Speeds	Output Torque	Ratio	Per.O. Loads (Output)	Service Factors	Type	Rated Current	Weight	Dim. Page	Price Ref.						
Leistung P <sub>g</sub> [kW] P <sub>g</sub> [HP]	Abtriebswelle Drehzahlen n <sub>2</sub> [r.p.m]	Abtriebswelle Drehmomente M <sub>2</sub> [Nm]	Übersetzung i	Zul.Querkräfte (Abtrieb) F <sub>qam</sub> [N]	Betriebsfaktor f <sub>s</sub>	Typ	Nennstrom [A]	Gewicht ~ [kg]	Maße Seite	Preis No.						
22 30	67	3013	20.97	57114	2.7	KR773-180L/4	36	551	154	KR210						
	69	2903	20.23	56758	2.7											
	80	2519	17.52	55300	3.0											
	92	2195	15.25	53829	3.3											
30 40	43	4664	32.68	24657	0.9	KR673-180L/4	36	412	142	KR211						
	50	4017	28.10	31053	1.1											
	57	3492	24.38	34783	1.2											
	66	3057	21.32	34761	1.4											
	75	2691	18.74	34582	1.6											
	85	2379	16.54	34283	1.8											
	97	2074	14.49	33275	1.4											
	112	1787	12.46	32749	1.6											
	130	1553	10.81	32156	1.7											
	148	1360	9.45	31523	1.9											
	169	1197	8.31	30863	2.1											
	30 40	88	2274	15.88	22643						0.8	KR573-180L/4	36	334	130	KR212
104		1940	13.53	22658	0.9											
121		1663	11.58	22518	1.0											
125		1605	11.22	21698	0.9											
148		1359	9.48	21506	1.0											
173		1160	8.07	21206	1.1											
203		994	6.91	20827	1.2											
30 40		187	1075	7.48	11849	0.8	KR473-180L/4	36	292	118	KR213					
	225	894	6.21	11898	0.9											
30 40	17	15704	81.06	75080	1.0	KR873-200L/4	54	837	166	KR214						
	20	13730	70.76	85077	1.1											
	22	12130	62.42	91916	1.2											
	25	10805	55.53	96855	1.4											
	28	9690	49.75	100818	1.5											
	32	8421	43.22	105597	1.8											
	37	7414	38.00	105651	1.9											
	41	6698	34.28	103805	2.1											
	47	5844	29.88	101215	2.3											
	58	4755	24.28	97124	3.0											
	30 40	27	9929	51.13	41528						0.8	KR773-200L/4	54	570	154	KR215
		31	8820	45.36	49772						0.9					
		35	7873	40.44	54591						1.0					
		36	7585	39.00	54691						1.1					
		41	6580	33.78	54846						1.2					
		48	5734	29.40	54676						1.4					
		53	5182	26.52	54378						1.5					
		60	4603	23.52	53876						1.7					
67		4110	20.97	53261	1.9											
69		3960	20.23	53043	2.0											
80		3435	17.52	52082	2.2											
92		2994	15.25	51029	2.4											
109		2525	12.89	48032	1.8											
122		2243	11.44	47150	2.0											
137		2003	10.20	46248	2.1											
142		1929	9.83	45952	2.2											
164		1674	8.52	44746	2.4											
189		1459	7.41	43534	2.7											
30 40	57	4762	24.38	23534	0.9	KR673-200L/4	54	429	142	KR216						

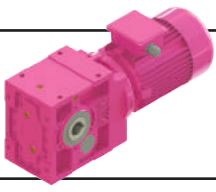

# K Serisi Motorlu Güç Devir Sayfaları

## K Series Geared Motors Performance Tables

### K Serien Getriebemotoren Leistung und Drehzahlübersicht

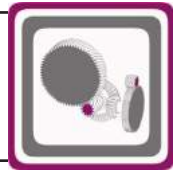

Güç	Çıkış Devri	Çıkış Momenti	Çevrim Oranı	Güv. Rad. Yük Çıkış	Servis Faktörü	Tipi	Anma Akımı	Ağırlık	Ölçü Sayfası	Fiyat Kodu						
Power	Output Speeds	Output Torque	Ratio	Per.O. Loads (Output)	Service Factors	Type	Rated Current	Weight	Dim. Page	Price Ref.						
Leistung P <sub>g</sub> [kW] P <sub>g</sub> [HP]	Abtriebswelle Drehzahlen n <sub>2</sub> [r.p.m]	Abtriebswelle Drehmomente M <sub>2</sub> [Nm]	Übersetzung i	Zul.Querkräfte (Abtrieb) F <sub>qam</sub> [N]	Betriebsfaktor f <sub>s</sub>	Typ	Nennstrom [A]	Gewicht ~ [kg]	Maße Seite	Preis No.						
30 40	66	4169	21.32	29773	1.0	KR673-200L/4	54	429	142	KR216						
	75	3670	18.74	30196	1.2											
	85	3244	16.54	30412	1.3											
	97	2829	14.49	29673	1.0											
	112	2437	12.46	29654	1.1											
	130	2118	10.81	29470	1.3											
	148	1855	9.45	29174	1.4											
	169	1633	8.31	28799	1.5											
37 50	25	13327	55.53	86648	1.1	KR873-225S/4	66	885	166	KR217						
	28	11952	49.75	92596	1.3											
	32	10386	43.22	99278	1.4											
	37	9145	38.00	100930	1.6											
	41	8261	34.28	99545	1.7											
	47	7209	29.88	97504	1.8											
	58	5865	24.28	94109	2.4											
	66	5164	21.34	91866	2.6											
	73	4665	19.26	90019	2.8											
	83	4071	16.78	87493	3.1											
	101	3372	13.93	82770	2.6											
	114	2969	12.25	80495	2.8											
	127	2682	11.05	78665	3.0											
		35	9710	40.44	43215	0.8	KR773-225S/4	66	608	154	KR218					
		36	9356	39.00	45952	0.9										
		41	8116	33.78	49416	1.0										
		48	7073	29.40	49950	1.1										
		53	6392	26.52	50115	1.3										
		60	5678	23.52	50094	1.4										
		67	5069	20.97	49890	1.6										
69		4884	20.23	49792	1.6											
80		4237	17.52	49266	1.8											
92		3693	15.25	48578	2.0											
109		3115	12.89	45587	1.4											
122		2767	11.44	44981	1.6											
137		2470	10.20	44314	1.7											
142		2380	9.83	44087	1.8											
164		2065	8.52	43131	2.0											
189		1799	7.41	42129	2.2											
		66	5142	21.32	18017	0.8						KR673-225S/4	66	467	142	KR219
		75	4527	18.74	26359	0.9										
	85	4001	16.54	27024	1.1											
	112	3006	12.46	26945	0.9											
	130	2613	10.81	27119	1.0											
	148	2288	9.45	27119	1.1											
	169	2014	8.31	26992	1.2											
	45 60	25	16209	55.53	72072	0.9	KR873-225M/4	80	911	166	KR220					
28		14537	49.75	81083	1.0											
32		12633	43.22	90803	1.2											
37		11123	38.00	95532	1.3											
41		10048	34.28	94675	1.4											
47		8768	29.88	93261	1.5											
58		7133	24.28	90663	2.0											
66		6281	21.34	88836	2.2											
73		5674	19.26	87285	2.3											
83		4951	16.78	85111	2.5											
101		4102	13.93	80525	2.1											
114		3612	12.25	78522	2.3											
127		3263	11.05	76885	2.5											
145		2847	9.63	74658	2.8											

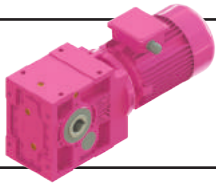

# K Serisi Motorlu Güç Devir Sayfaları

## K Series Geared Motors Performance Tables

### K Serien Getriebemotoren Leistung und Drehzahlübersicht



Güç	Çıkış Devri	Çıkış Momenti	Çevrim Oranı	Güv. Rad. Yük Çıkış	Servis Faktörü	Tipi	Anma Akımı	Ağırlık	Ölçü Sayfası	Fiyat Kodu						
Power	Output Speeds	Output Torque	Ratio	Per.O. Loads (Output)	Service Factors	Type	Rated Current	Weight	Dim. Page	Price Ref.						
Leistung P <sub>g</sub> [kW] P <sub>g</sub> [HP]	Abtriebswelle Drehzahlen n <sub>2</sub> [r.p.m]	Abtriebswelle Drehmomente M <sub>2</sub> [Nm]	Übersetzung i	Zul.Querkräfte (Abtrieb) F <sub>qam</sub> [N]	Betriebsfaktor f <sub>s</sub>	Typ	Nennstrom [A]	Gewicht ~ [kg]	Maße Seite	Preis No.						
45 60	41	9872	33.78	41799	0.8	KR773-225M/4	80	637	154	KR221						
	48	8603	29.40	44549	0.9											
	53	7775	26.52	45244	1.0											
	60	6906	23.52	45773	1.2											
	67	6165	20.97	46037	1.3											
	69	5940	20.23	46076	1.3											
	80	5154	17.52	46048	1.5											
	92	4491	15.25	45777	1.6											
	109	3788	12.89	42793	1.2											
	122	3365	11.44	42502	1.3											
	137	3005	10.20	42104	1.4											
	142	2895	9.83	41956	1.5											
	164	2511	8.52	41285	1.6											
	189	2189	7.41	40522	1.8											
	85 97 112 130 148 169	85	4867	16.54	22060						0.9	KR673-225M/4	80	496	142	KR222
		97	4244	14.49	22921						0.7					
		112	3656	12.46	23849						0.8					
		130	3178	10.81	24432						0.8					
148		2783	9.45	24770	0.9											
169		2450	8.31	24927	1.0											
55 75		25	19812	55.53	44582	0.8	KR873-250M/4	97	1023	166	KR223					
	28	17768	49.75	62040	0.8											
	32	15440	43.22	77807	1.0											
	37	13595	38.00	88781	1.0											
	41	12281	34.28	88585	1.1											
	47	10717	29.88	87954	1.2											
	58	8719	24.28	86353	1.6											
	66	7677	21.34	85047	1.8											
	73	6935	19.26	83867	1.9											
	83	6052	16.78	82133	2.1											
	101	5013	13.93	77718	1.7											
	114	4414	12.25	76054	1.9											
	127	3988	11.05	74658	2.0											
	145	3480	9.63	72718	2.3											
	53 60 67 69 80 92 109 122 137 142 164 189	53	9502	26.52	39154	0.8						KR773-250M/4	97	748	154	KR224
		60	8441	23.52	40371	0.9										
		67	7536	20.97	41220	1.1										
		69	7261	20.23	41431	1.1										
80		6299	17.52	42025	1.2											
92		5490	15.25	42276	1.3											
109		4631	12.89	39300	1.0											
122		4114	11.44	39403	1.1											
137		3672	10.20	39341	1.2											
142		3538	9.83	39292	1.2											
164		3070	8.52	38977	1.3											
189		2675	7.41	38514	1.5											
75 97	37	18539	38.00	61980	0.8	KR873-280S/4	133	1173	166	KR225						
	41	16748	34.28	76393	0.8											
	47	14615	29.88	77334	0.9											
	58	11890	24.28	77727	1.2											
	66	10470	21.34	77465	1.3											
	73	9458	19.26	77027	1.4											
	83	8253	16.78	76173	1.5											
	101	6837	13.93	72100	1.3											
	114	6020	12.25	71116	1.4											
	127	5439	11.05	70203	1.5											
	145	4746	9.63	68837	1.7											

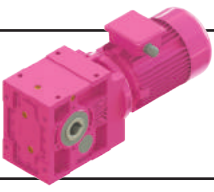

## K Serisi Motorlu Güç Devir Sayfaları

### K Series Geared Motors Performance Tables

### K Serien Getriebemotoren Leistung und Drehzahlübersicht



Güç	Çıkış Devri	Çıkış Momenti	Çevrim Oranı	Güv. Rad. Yük Çıkış	Servis Faktörü	Tipi	Anma Akımı	Ağırlık	Ölçü Sayfası	Fiyat Kodu
Power	Output Speeds	Output Torque	Ratio	Per.O. Loads (Output)	Service Factors	Type	Rated Current	Weight	Dim. Page	Price Ref.
Leistung P <sub>g</sub> [kW] P <sub>g</sub> [HP]	Abtriebswelle Drehzahlen n <sub>2</sub> [r.p.m]	Abtriebswelle Drehmomente M <sub>2</sub> [Nm]	Übersetzung i	Zul.Querkräfte (Abtrieb) F <sub>qam</sub> [N]	Betriebsfaktor f <sub>s</sub>	Typ	Nennstrom [A]	Gewicht ~ [kg]	Maße Seite	Preis No.
<b>90</b>	47	17538	<b>29.88</b>	69361	0.8	<b>KR873-280M/4</b>	158	1237	166	KR226
117	58	14269	<b>24.28</b>	71253	1.0					
	66	12564	<b>21.34</b>	71775	1.1					
	73	11350	<b>19.26</b>	71894	1.2					
	83	9905	<b>16.78</b>	71701	1.3					
	101	8205	<b>13.93</b>	67884	1.1					
	114	7225	<b>12.25</b>	67410	1.2					
	127	6527	<b>11.05</b>	66860	1.2					
	145	5696	<b>9.63</b>	65924	1.4					

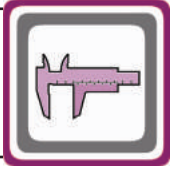
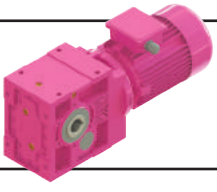

# Ölçü Sayfaları

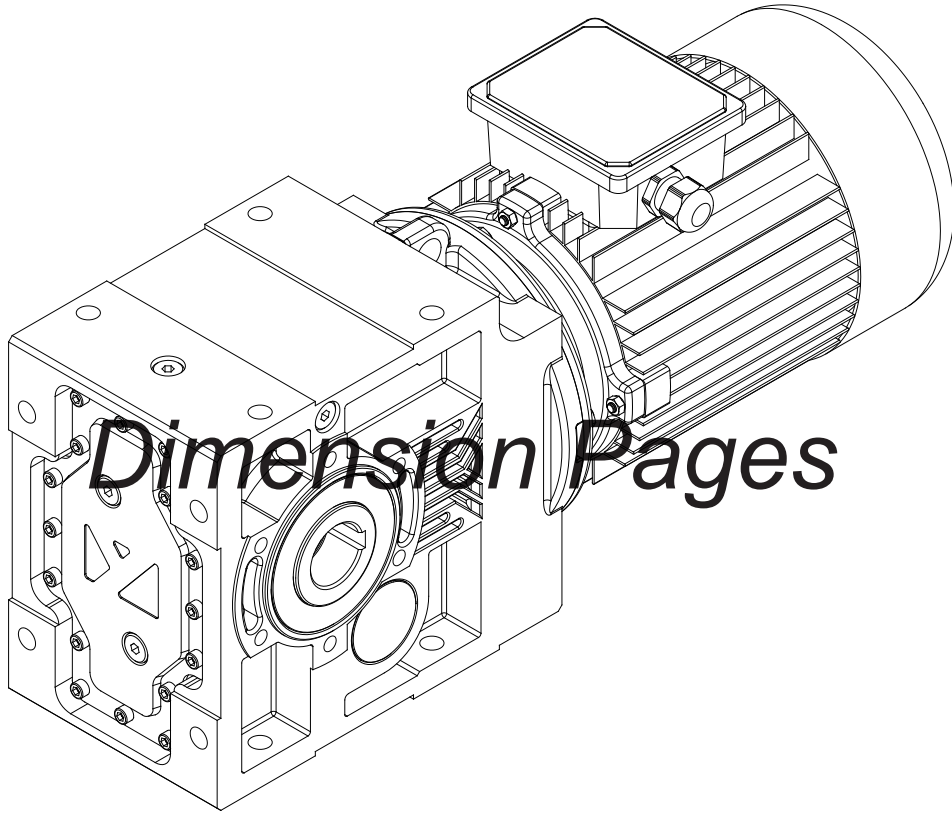

Abmessungsseiten

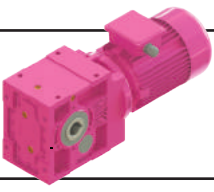

# Ölçü Sayfaları Dimension Pages Abmessungsseiten

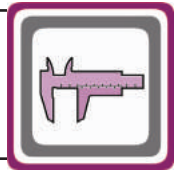

-Mil ucu çekirtme deliği DIN 332 sayfa 2 / Tapped center hole to DIN 332, sheet 2 / Zentrierung mit gewinde DIN 332, Blatt 2

KR002.00  
KR003.00

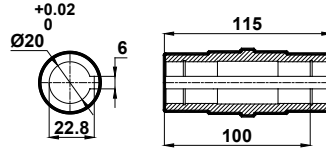
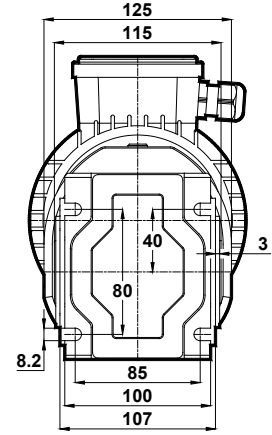
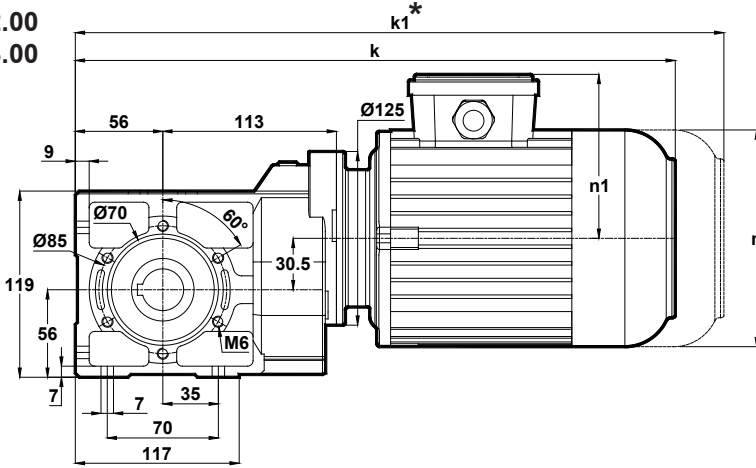

	63	71	80	90S	90L
k	366	385	413	441	466
k1	419	505	533	566	591
n	116	138	156	176	176
n1	97	110	118	126	126

Klemens Pozisyonları  
Terminal Box Positions  
Klemmenkasten Positionen

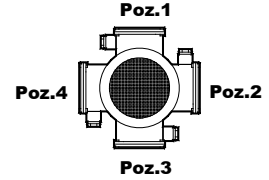

63-71-80-90  
Tip / Type / Typ

KR002.01  
KR003.01

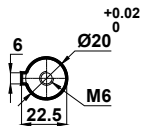
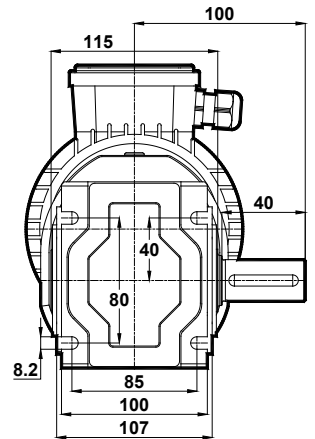
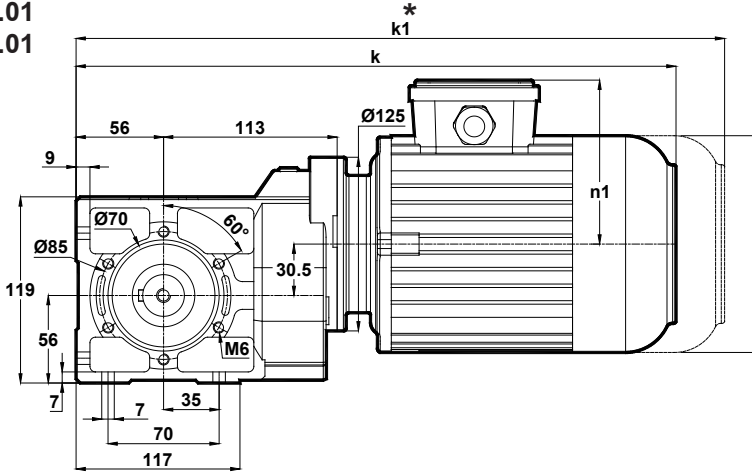

	63	71	80	90S	90L
k	366	385	413	441	466
k1	419	505	533	566	591
n	116	138	156	176	176
n1	97	110	118	126	126

\* "k1" Ölçüsü frenli redüktörlere aittir.  
Dimension "k1" is for motors with brake.  
Maße "k1" ist für Bremsenmotoren.

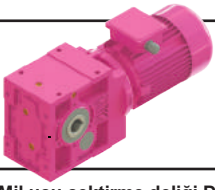

# Ölçü Sayfaları Dimension Pages Abmessungsseiten

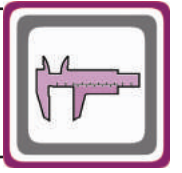

-Mil ucu çektirme deliği DIN 332 sayfa 2 / Tapped center hole to DIN 332, sheet 2 / Zentrierung mit gewinde DIN 332, Blatt 2

KR002.02  
KR003.02

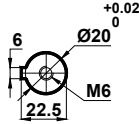
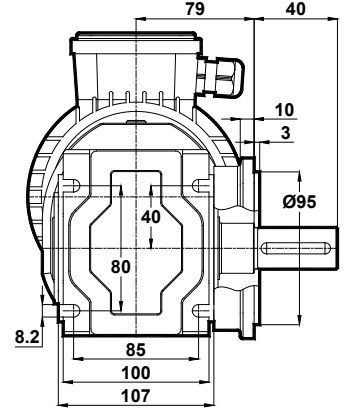
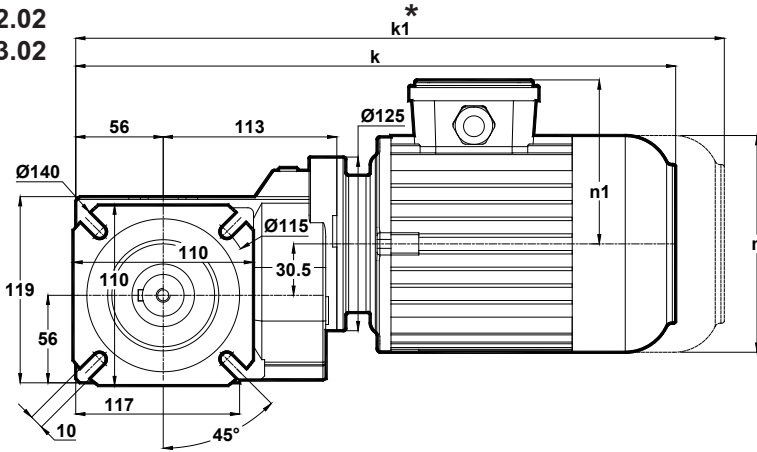

	63	71	80	90S	90L
k	366	385	413	441	466
k1	419	505	533	566	591
n	116	138	156	176	176
n1	97	110	118	126	126

Klemens Pozisyonları  
Terminal Box Positions  
Klemmenkasten Positionen

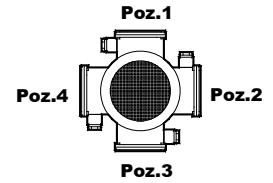

63-71-80-90  
Tip / Type / Typ

KR002.03  
KR003.03

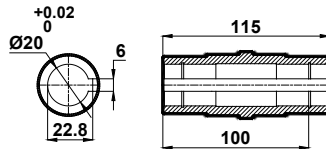
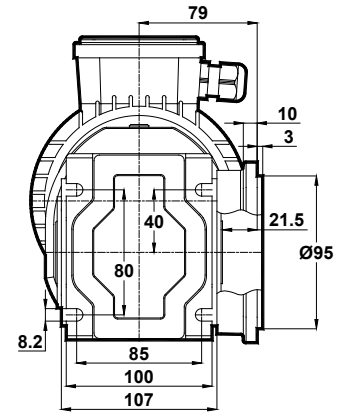
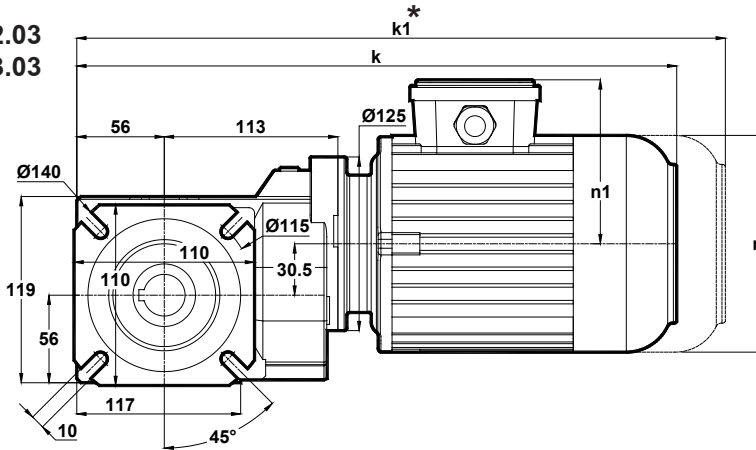

	63	71	80	90S	90L
k	366	385	413	441	466
k1	419	505	533	566	591
n	116	138	156	176	176
n1	97	110	118	126	126

\* " k1 " Ölçüsü frenli redüktörlere aittir.  
Dimension " k1 " is for motors with brake.  
Maße " k1 " ist für Bremsenmotoren.

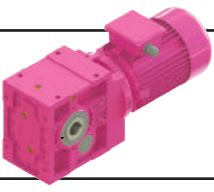

# Ölçü Sayfaları Dimension Pages Abmessungsseiten

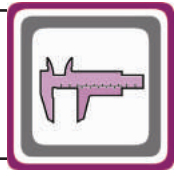

-Mil ucu çektirme deliği DIN 332 sayfa 2 / Tapped center hole to DIN 332, sheet 2 / Zentrierung mit gewinde DIN 332, Blatt 2

KR002.04  
KR003.04

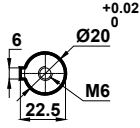
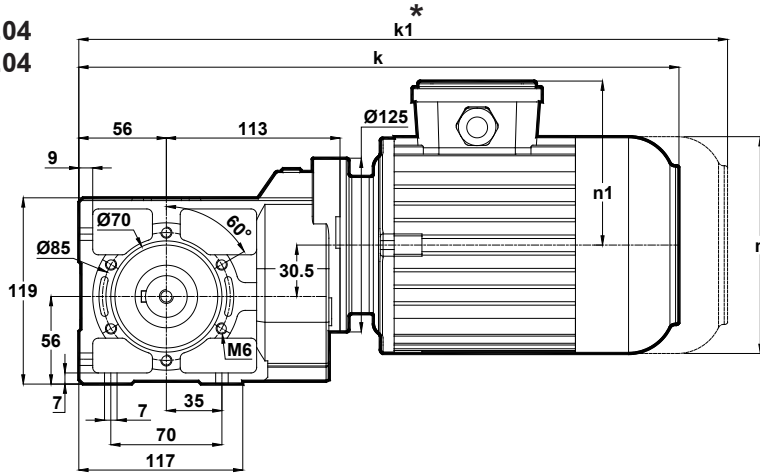

	63	71	80	90S	90L
k	366	385	413	441	466
k1	419	505	533	566	591
n	116	138	156	176	176
n1	97	110	118	126	126

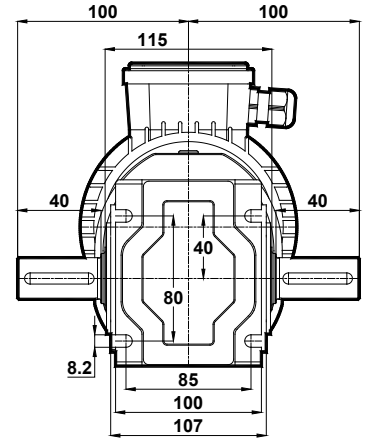

Klemens Pozisyonları  
Terminal Box Positions  
Klemmenkasten Positionen

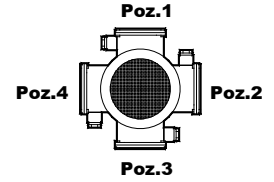

63-71-80-90  
Tip / Type / Typ

KR002.05  
KR003.05

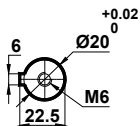
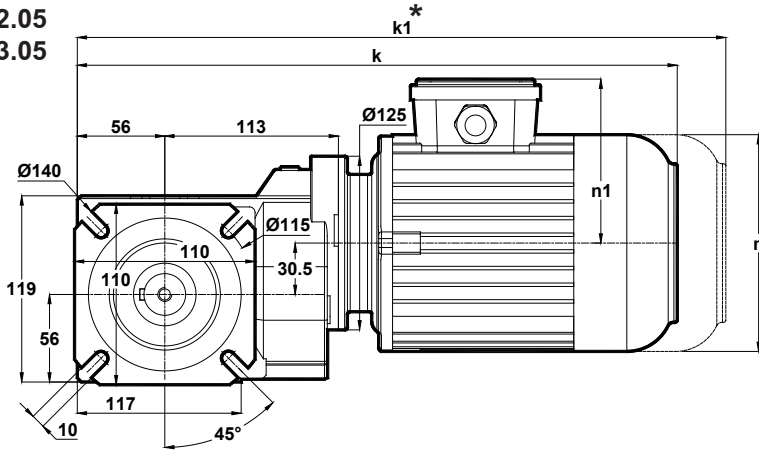

	63	71	80	90S	90L
k	366	385	413	441	466
k1	419	505	533	566	591
n	116	138	156	176	176
n1	97	110	118	126	126

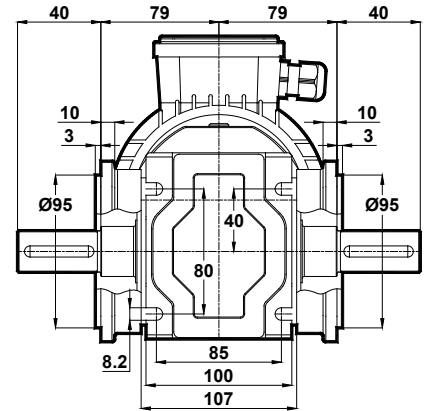

\* "k1" Ölçüsü frenli redüktörlere aittir.  
Dimension "k1" is for motors with brake.  
Maße "k1" ist für Bremsenmotoren.

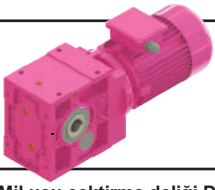

# Ölçü Sayfaları Dimension Pages Abmessungsseiten

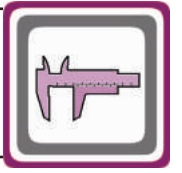

-Mil ucu çektirme deliği DIN 332 sayfa 2 / Tapped center hole to DIN 332, sheet 2 / Zentrierung mit gewinde DIN 332, Blatt 2

KR002.08  
KR003.08

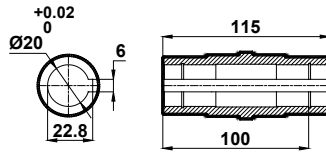
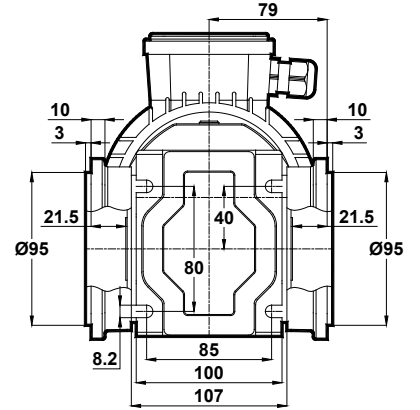
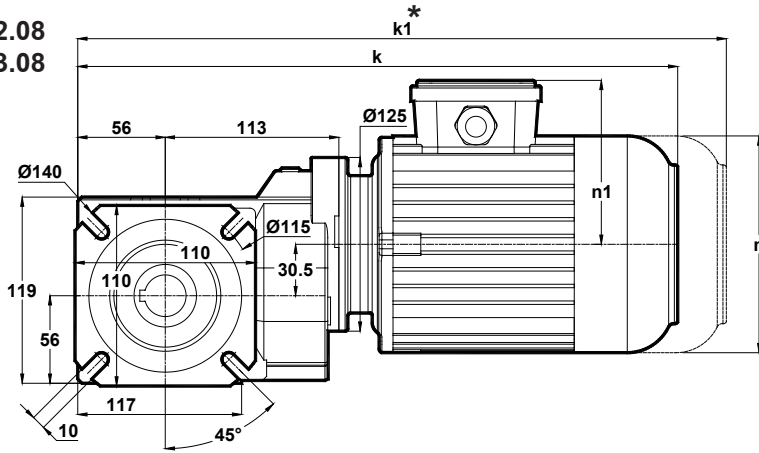

Klemens Pozisyonları  
Terminal Box Positions  
Klemmenkasten Positionen

	63	71	80	90S	90L
k	366	385	413	441	466
k1	419	505	533	566	591
n	116	138	156	176	176
n1	97	110	118	126	126

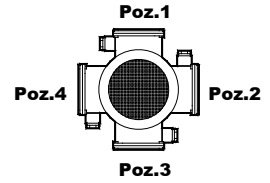

63-71-80-90  
Tip / Type / Typ

\* " k1 " Ölçüsü frenli redüktörlere aittir.  
Dimension " k1 " is for motors with brake.  
Maße " k1 " ist für Bremsenmotoren.

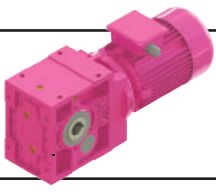

# Ölçü Sayfaları

## Dimension Pages

### Abmessungsseiten

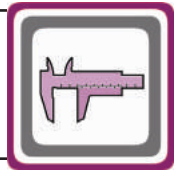

-Mil ucu çekirme deliği DIN 332 sayfa 2 / Tapped center hole to DIN 332, sheet 2 / Zentrierung mit gewinde DIN 332, Blatt 2

KR102.00  
KR103.00

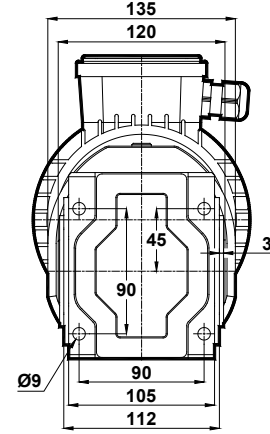
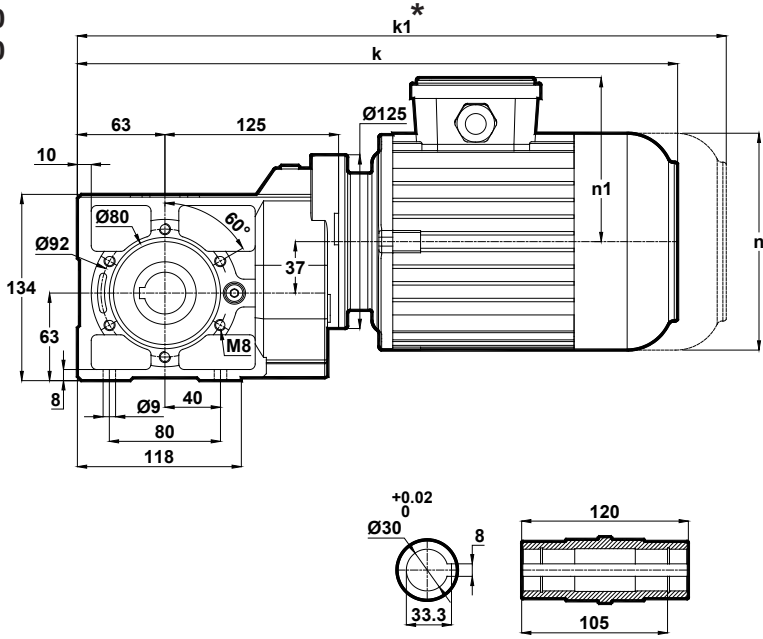

Klemens Pozisyonları  
Terminal Box Positions  
Klemmenkasten Positionen

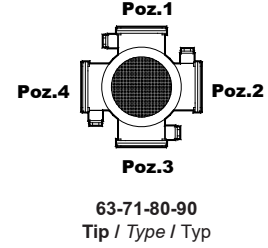

	63	71	80	90S	90L
k	385	404	432	460	485
k1	438	524	552	585	610
n	116	138	156	176	176
n1	97	110	118	126	126

KR102.01  
KR103.01

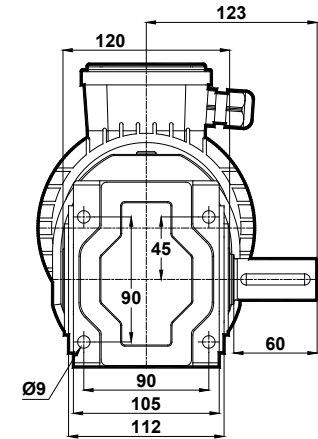
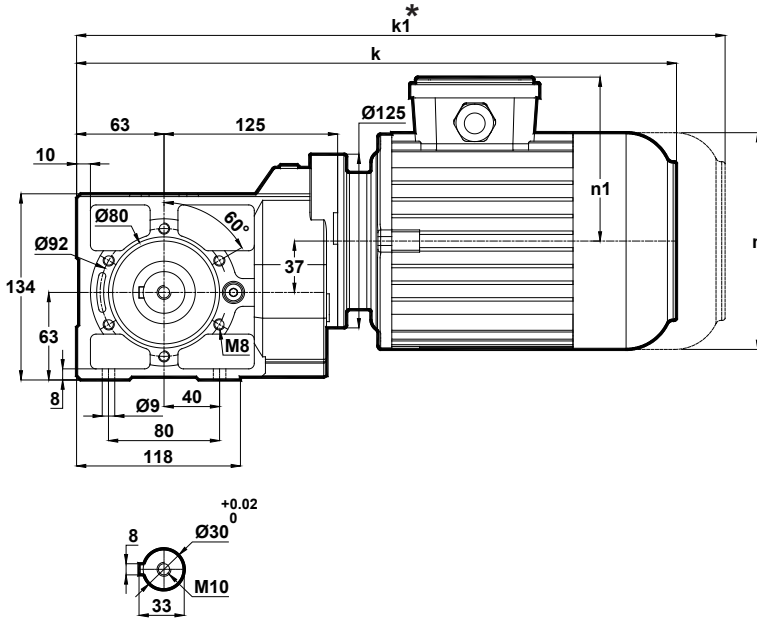

	63	71	80	90S	90L
k	385	404	432	460	485
k1	438	524	552	585	610
n	116	138	156	176	176
n1	97	110	118	126	126

\* "k1" Ölçüsü frenli redüktörlere aittir.  
Dimension "k1" is for motors with brake.  
Maße "k1" ist für Bremsenmotoren.

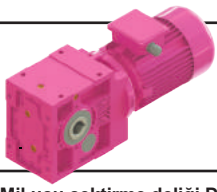

# Ölçü Sayfaları Dimension Pages Abmessungsseiten

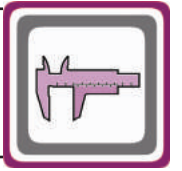

-Mil ucu çektirme deliği DIN 332 sayfa 2 / Tapped center hole to DIN 332, sheet 2 / Zentrierung mit gewinde DIN 332, Blatt 2

KR102.02  
KR103.02

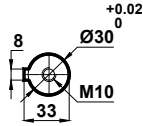
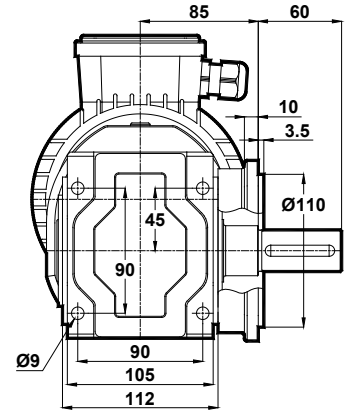
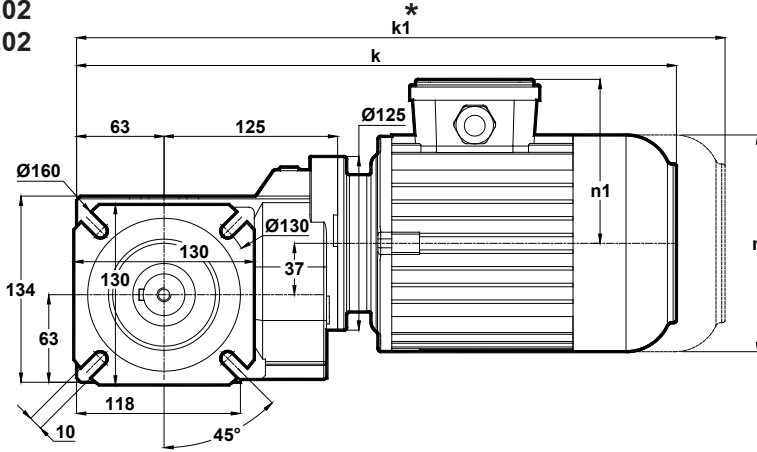

Klemens Pozisyonları  
Terminal Box Positions  
Klemmenkasten Positionen

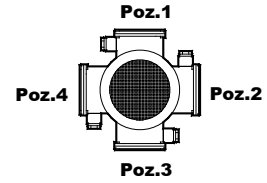

63-71-80-90  
Tip / Type / Typ

	63	71	80	90S	90L
k	385	404	432	460	485
k1	438	524	552	585	610
n	116	138	156	176	176
n1	97	110	118	126	126

KR102.03  
KR103.03

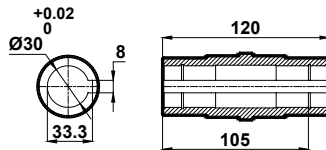
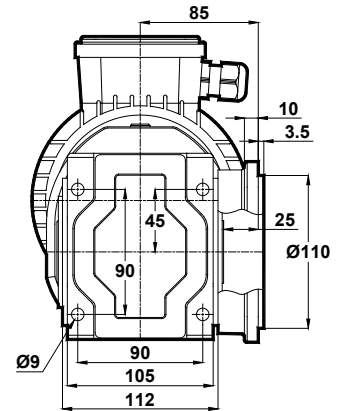
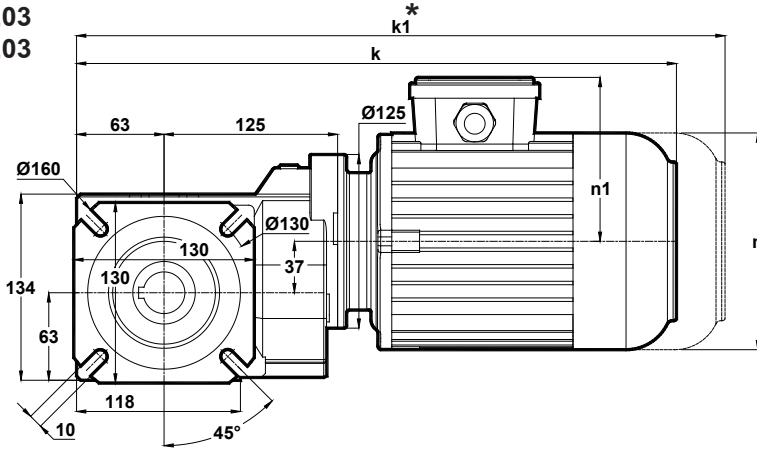

	63	71	80	90S	90L
k	385	404	432	460	485
k1	438	524	552	585	610
n	116	138	156	176	176
n1	97	110	118	126	126

\* "k1" Ölçüsü frenli redüktörlere aittir.  
Dimension "k1" is for motors with brake.  
Maße "k1" ist für Bremsenmotoren.

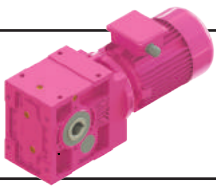

# Ölçü Sayfaları Dimension Pages Abmessungsseiten

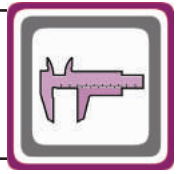

-Mil ucu çekirme deliği DIN 332 sayfa 2 / Tapped center hole to DIN 332, sheet 2 / Zentrierung mit gewinde DIN 332, Blatt 2

KR102.04  
KR103.04

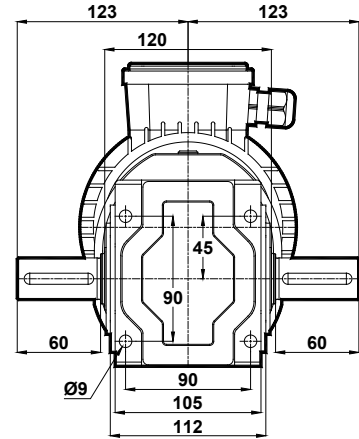
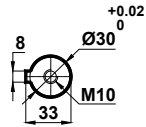
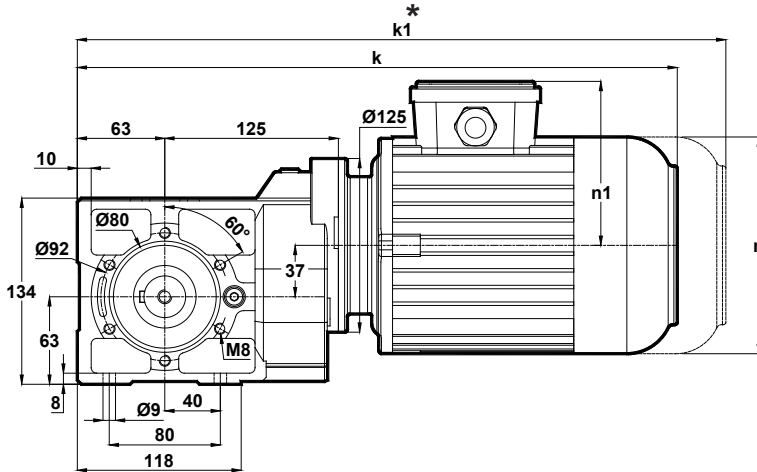

Klemens Pozisyonları  
Terminal Box Positions  
Klemmenkasten Positionen

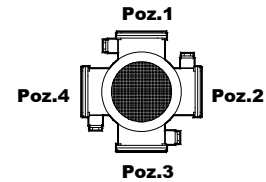

63-71-80-90  
Tip / Type / Typ

	63	71	80	90S	90L
k	385	404	432	460	485
k1	438	524	552	585	610
n	116	138	156	176	176
n1	97	110	118	126	126

KR102.05  
KR103.05

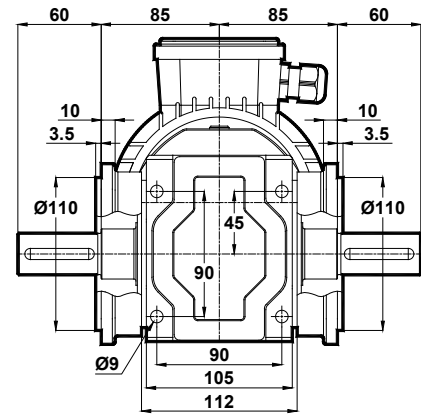
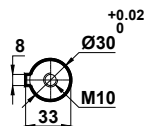
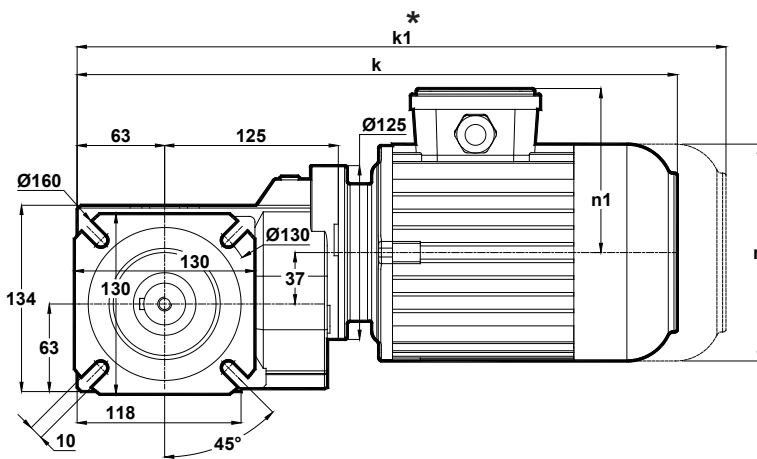

	63	71	80	90S	90L
k	385	404	432	460	485
k1	438	524	552	585	610
n	116	138	156	176	176
n1	97	110	118	126	126

\* "k1" Ölçüsü frenli redüktörlere aittir.  
Dimension "k1" is for motors with brake.  
Maße "k1" ist für Bremsenmotoren.

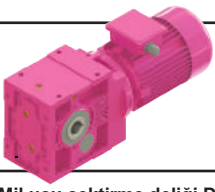

# Ölçü Sayfaları Dimension Pages Abmessungsseiten

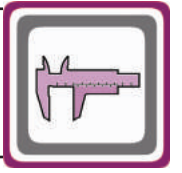

-Mil ucu çektirme deliği DIN 332 sayfa 2 / Tapped center hole to DIN 332, sheet 2 / Zentrierung mit gewinde DIN 332, Blatt 2

KR102.08  
KR103.08

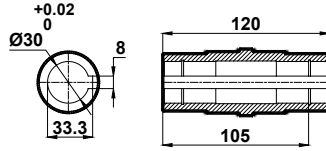
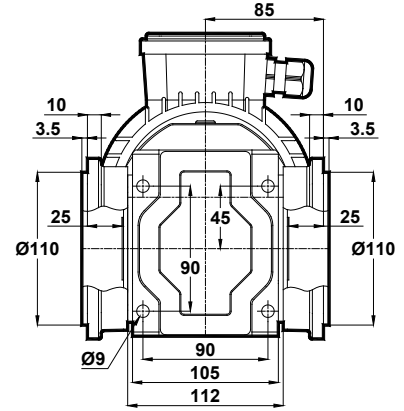
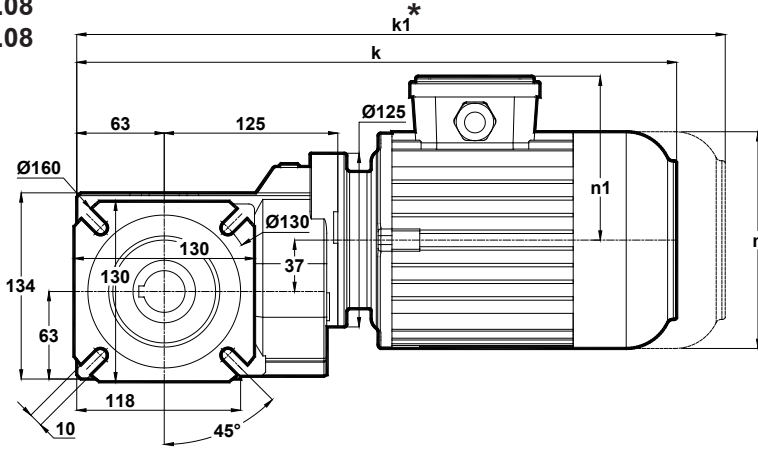

Klemens Pozisyonları  
Terminal Box Positions  
Klemmenkasten Positionen

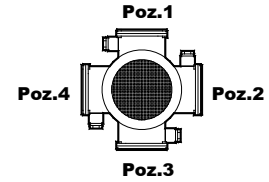

63-71-80-90  
Tip / Type / Typ

	63	71	80	90S	90L
k	385	404	432	460	485
k1	438	524	552	585	610
n	116	138	156	176	176
n1	97	110	118	126	126

\* " k1 " Ölçüsü frenli redüktörlere aittir.  
Dimension " k1 " is for motors with brake.  
Maße " k1 " ist für Bremsenmotoren.

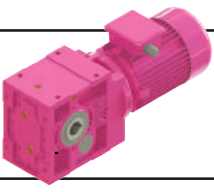

# Ölçü Sayfaları

## Dimension Pages

### Abmessungsseiten

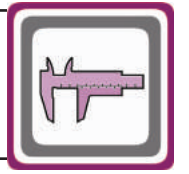

-Mil ucu çektirme deliği DIN 332 sayfa 2 / Tapped center hole to DIN 332, sheet 2 / Zentrierung mit gewinde DIN 332, Blatt 2

KR202.00  
KR203.00

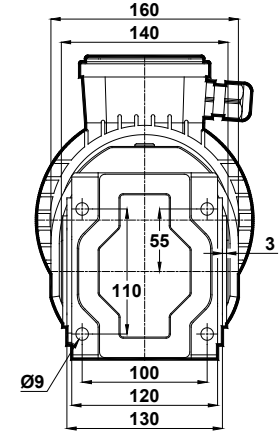
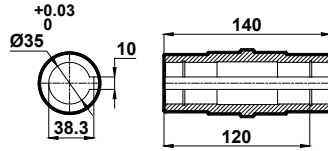
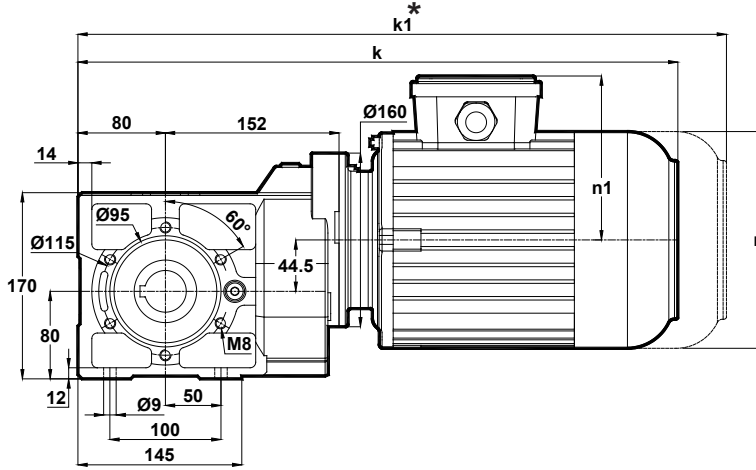

Klemens Pozisyonları  
Terminal Box Positions  
Klemmenkasten Positionen

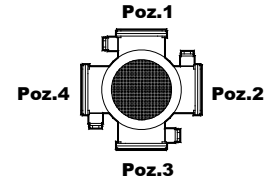

63-71-80-90-100-112  
Tip / Type / Typ

	63	71	80	90S	90L	100L	112M
k	425	444	473	500	525	566	589
k1	478	564	593	625	650	701	724
n	116	138	156	176	176	194	218
n1	97	110	118	126	126	135	146

KR202.01  
KR203.01

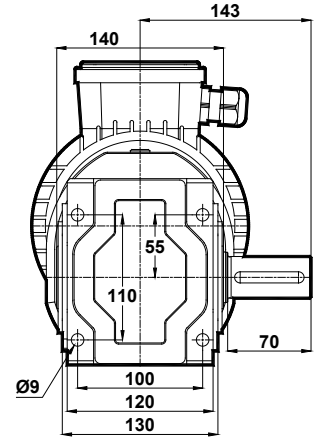
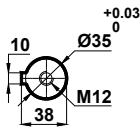
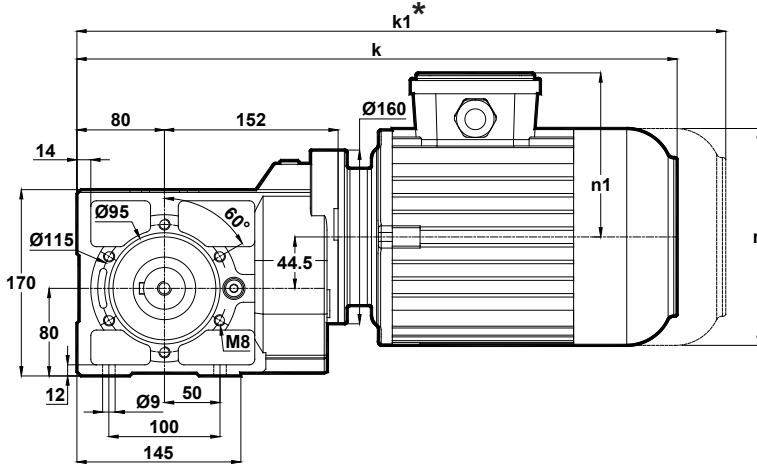

	63	71	80	90S	90L	100L	112M
k	425	444	473	500	525	566	589
k1	478	564	593	625	650	701	724
n	116	138	156	176	176	194	218
n1	97	110	118	126	126	135	146

\* "k1" Ölçüsü frenli redüktörlere aittir.  
Dimension "k1" is for motors with brake.  
Maße "k1" ist für Bremsmotoren.

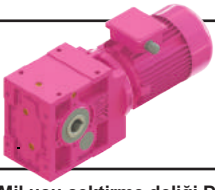

# Ölçü Sayfaları Dimension Pages Abmessungsseiten

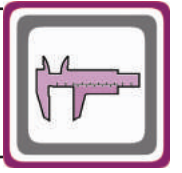

-Mil ucu çektirme deliği DIN 332 sayfa 2 / Tapped center hole to DIN 332, sheet 2 / Zentrierung mit gewinde DIN 332, Blatt 2

KR202.02  
KR203.02

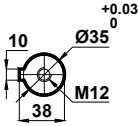
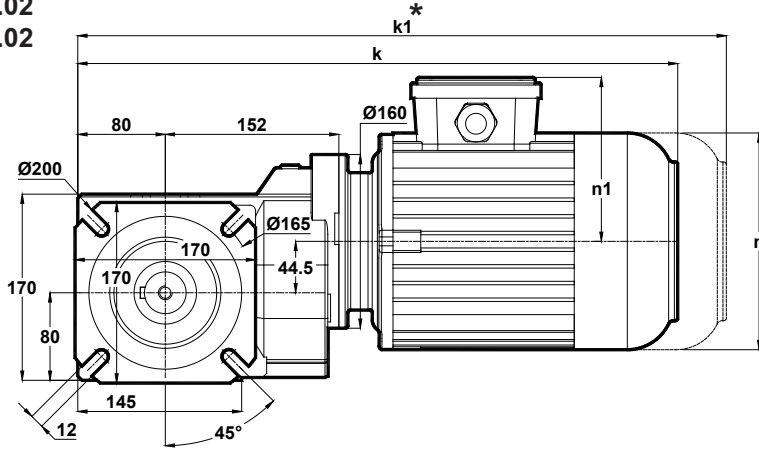

	63	71	80	90S	90L	100L	112M
k	425	444	473	500	525	566	589
k1	478	564	593	625	650	701	724
n	116	138	156	176	176	194	218
n1	97	110	118	126	126	135	146

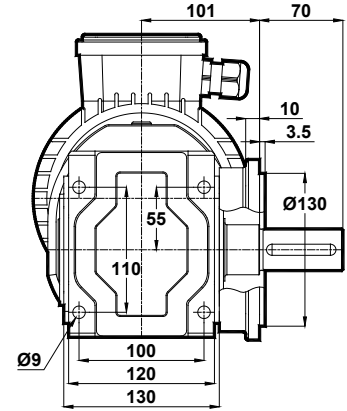

Klemens Pozisyonları  
Terminal Box Positions  
Klemmenkasten Positionen

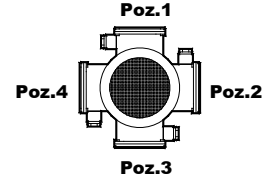

63-71-80-90-100-112  
Tip / Type / Typ

KR202.03  
KR203.03

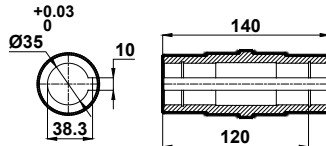
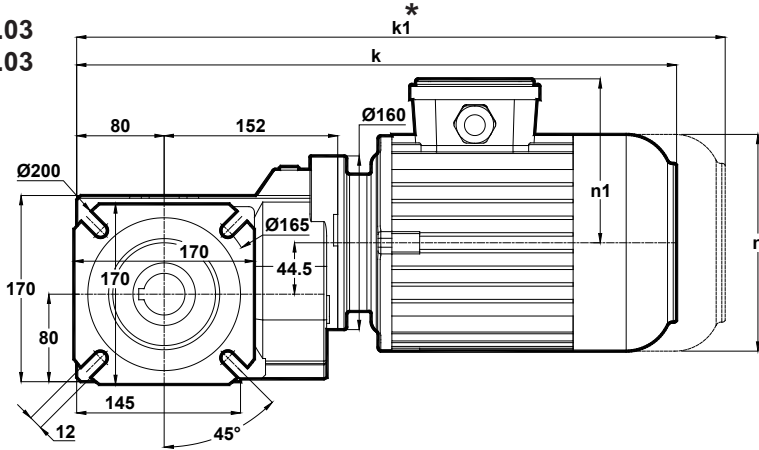

	63	71	80	90S	90L	100L	112M
k	425	444	473	500	525	566	589
k1	478	564	593	625	650	701	724
n	116	138	156	176	176	194	218
n1	97	110	118	126	126	135	146

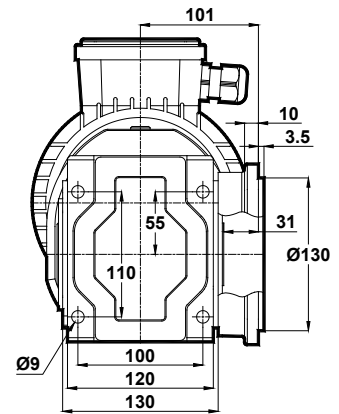

\* "k1" Ölçüsü frenli redüktörlere aittir.  
Dimension "k1" is for motors with brake.  
Maße "k1" ist für Bremsenmotoren.

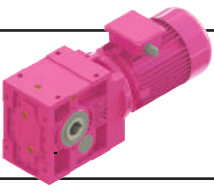

# Ölçü Sayfaları Dimension Pages Abmessungsseiten

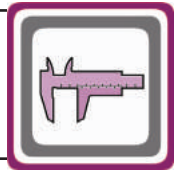

-Mil ucu çekirme deliği DIN 332 sayfa 2 / Tapped center hole to DIN 332, sheet 2 / Zentrierung mit gewinde DIN 332, Blatt 2

KR202.04  
KR203.04

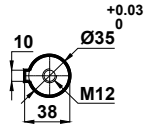
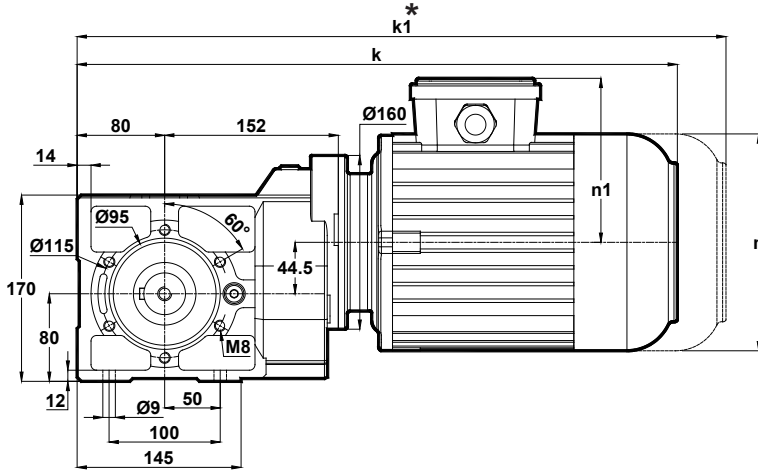

	63	71	80	90S	90L	100L	112M
k	425	444	473	500	525	566	589
k1	478	564	593	625	650	701	724
n	116	138	156	176	176	194	218
n1	97	110	118	126	126	135	146

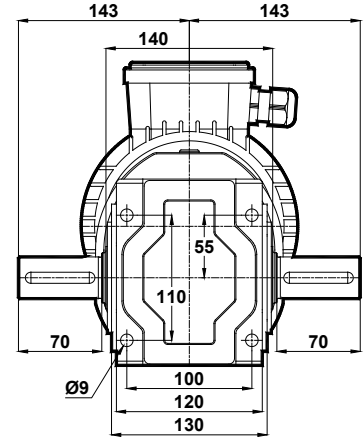

Klemens Pozisyonları  
Terminal Box Positions  
Klemmenkasten Positionen

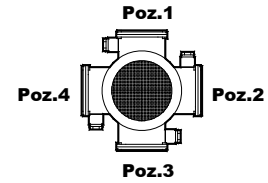

63-71-80-90-100-112  
Tip / Type / Typ

KR202.05  
KR203.05

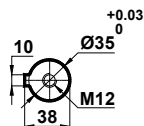
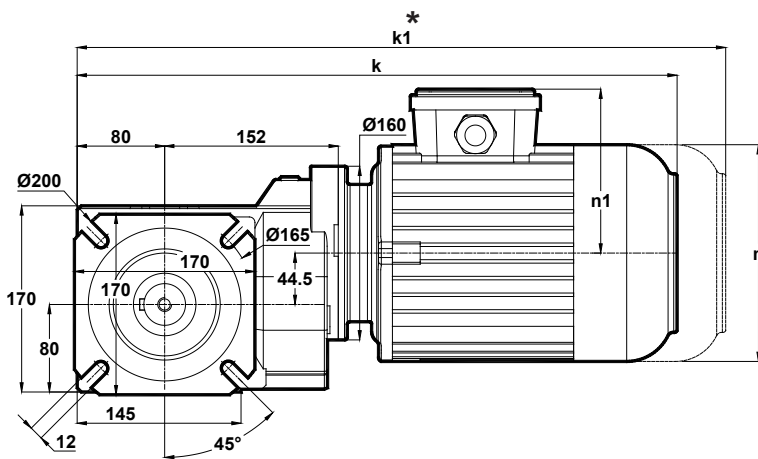

	63	71	80	90S	90L	100L	112M
k	425	444	473	500	525	566	589
k1	478	564	593	625	650	701	724
n	116	138	156	176	176	194	218
n1	97	110	118	126	126	135	146

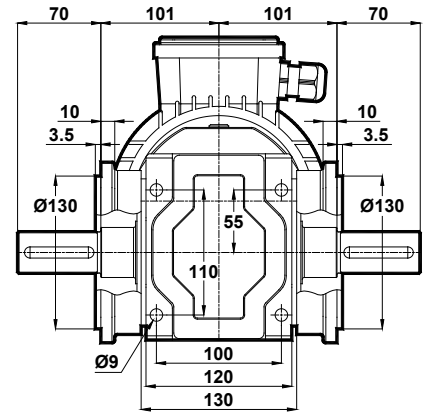

\* "k1" Ölçüsü frenli redüktörlere aittir.  
Dimension "k1" is for motors with brake.  
Maße "k1" ist für Bremsmotoren.

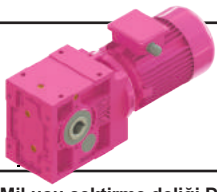

# Ölçü Sayfaları Dimension Pages Abmessungenseiten

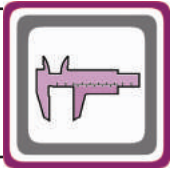

-Mil ucu çektirme deliği DIN 332 sayfa 2 / Tapped center hole to DIN 332, sheet 2 / Zentrierung mit gewinde DIN 332, Blatt 2

KR202.08  
KR203.08

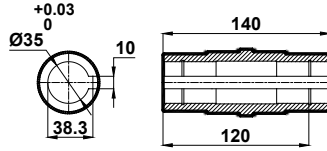
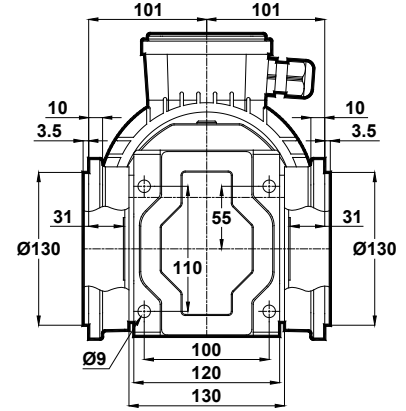
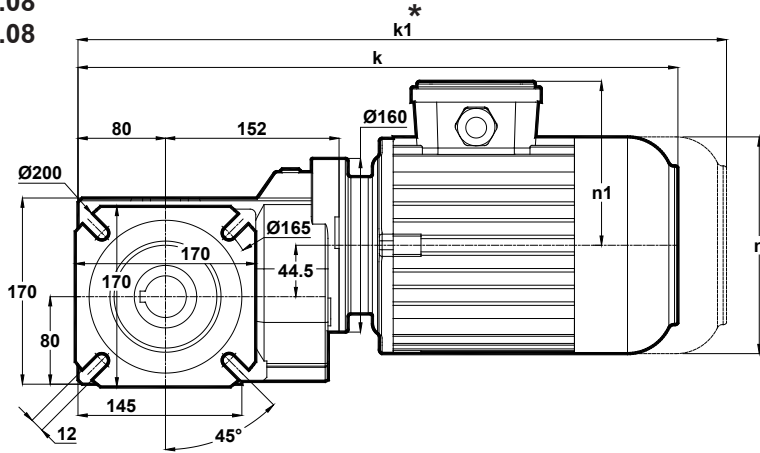

Klemens Pozisyonları  
Terminal Box Positions  
Klemmenkasten Positionen

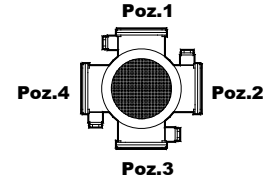

63-71-80-90-100-112  
Tip / Type / Typ

	63	71	80	90S	90L	100L	112M
k	425	444	473	500	525	566	589
k1	478	564	593	625	650	701	724
n	116	138	156	176	176	194	218
n1	97	110	118	126	126	135	146

\* " k1 " Ölçüsü frenli redüktörlere aittir.  
Dimension " k1 " is for motors with brake.  
Maße " k1 " ist für Bremsenmotoren.

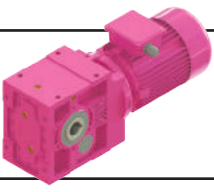

# Ölçü Sayfaları

## Dimension Pages

### Abmessungsseiten

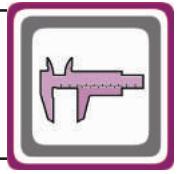

-Mil ucu çektirme deliği DIN 332 sayfa 2 / Tapped center hole to DIN 332, sheet 2 / Zentrierung mit gewinde DIN 332, Blatt 2

#### KR273.00

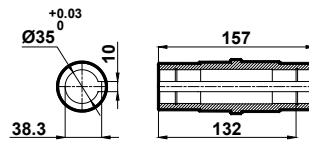
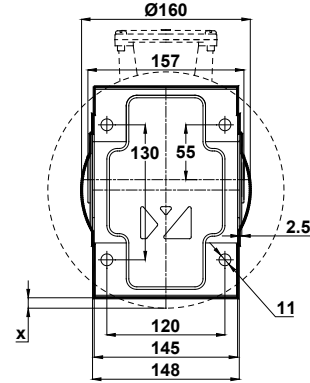
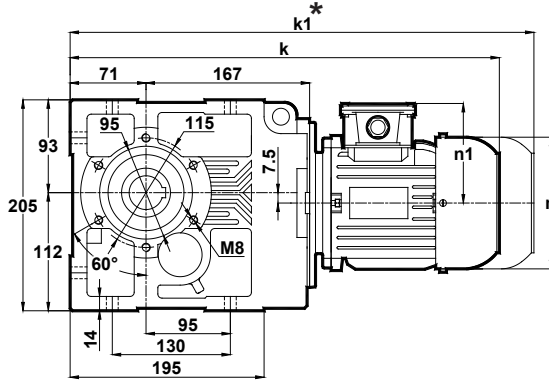

x: Motor Ayak bağlantı yüzeyinin altında ise  
x: If Motor is lower then foot mounting plane  
x:Wen motor ist nidriger den die Anschlußplatte

Klemens Pozisyonları  
Terminal Box Positions  
Klemmenkasten Positionen

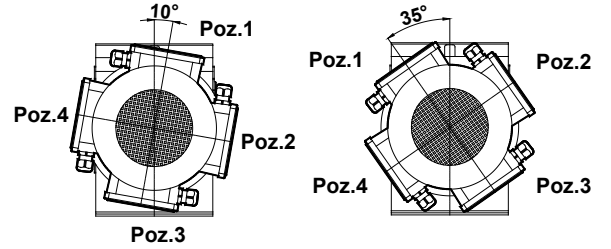

71  
Tip / Type / Typ

63-80-90-100-112  
Tip / Type / Typ

	63	71	80	90S	90L	100L	112M
k	431	449.5	478	506	531	572	595
k1	-	570	598	631	656	707	730
n	116	138	156	176	176	194	218
n1	97	110	118	126	126	135	146
x	-	-	-	-	-	-	4.5

#### KR273.01

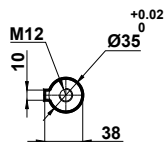
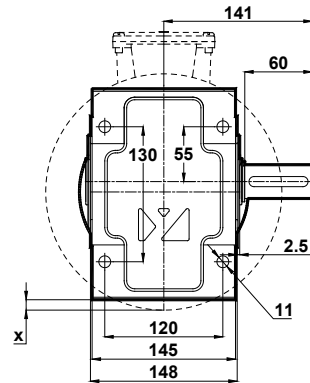
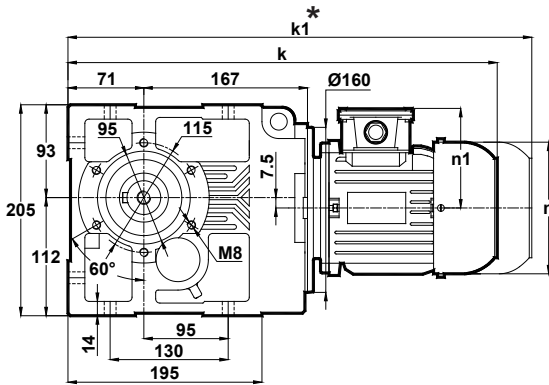

x: Motor Ayak bağlantı yüzeyinin altında ise  
x: If Motor is lower then foot mounting plane  
x:Wen motor ist nidriger den die Anschlußplatte

	63	71	80	90S	90L	100L	112M
k	431	449.5	478	506	531	572	595
k1	-	570	598	631	656	707	730
n	116	138	156	176	176	194	218
n1	97	110	118	126	126	135	146
x	-	-	-	-	-	-	4.5

\* " k1 " Ölçüsü frenli redüktörlere aittir.  
Dimension " k1 " is for motors with brake.  
Maße " k1 " ist für Bremsenmotoren.

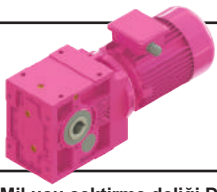

# Ölçü Sayfaları Dimension Pages Abmessungsseiten

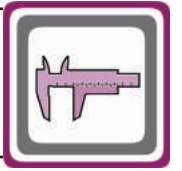

-Mil ucu çektirme deliği DIN 332 sayfa 2 / Tapped center hole to DIN 332, sheet 2 / Zentrierung mit gewinde DIN 332, Blatt 2

## KR273.02

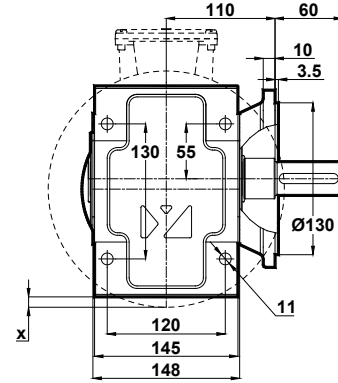
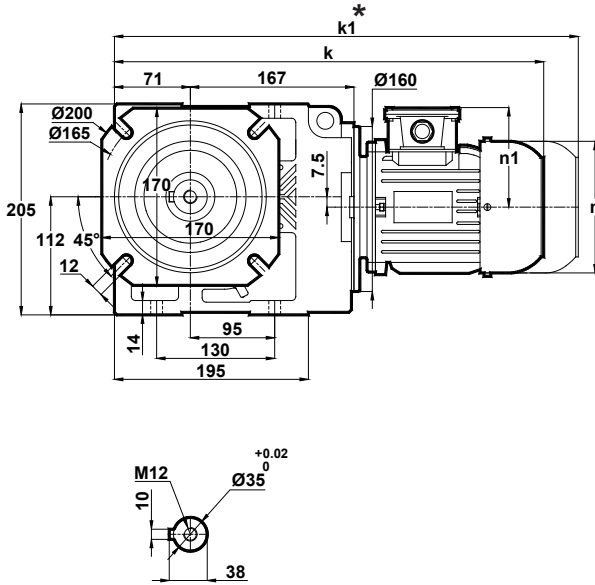

x: Motor Ayak bağlantı yüzeyinin altında ise  
x: If Motor is lower than foot mounting plane  
x:Wen motor ist nidriger den die Anschlußplatte

Klemens Pozisyonları  
Terminal Box Positions  
Klemmenkasten Positionen

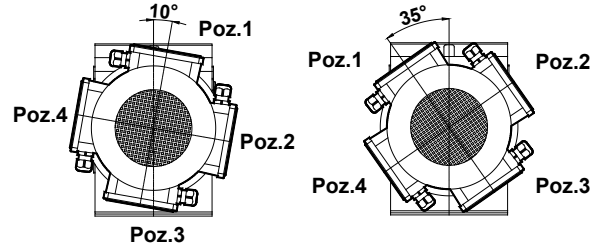

71  
Tip / Type / Typ

63-80-90-100-112  
Tip / Type / Typ

	63	71	80	90S	90L	100L	112M
k	431	449.5	478	506	531	572	595
k1	-	570	598	631	656	707	730
n	116	138	156	176	176	194	218
n1	97	110	118	126	126	135	146
x	-	-	-	-	-	-	4.5

## KR273.03

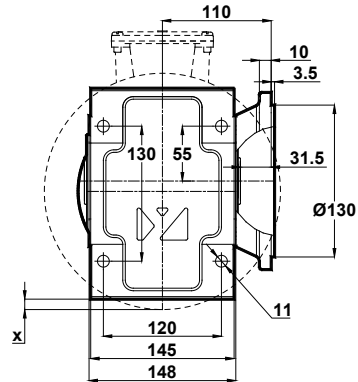
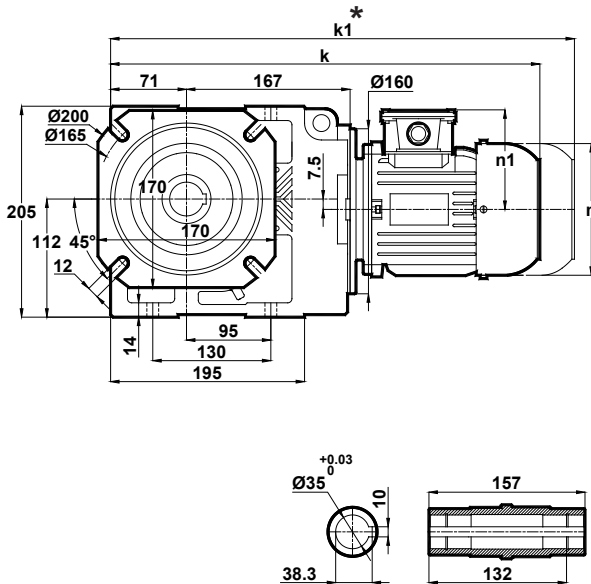

x: Motor Ayak bağlantı yüzeyinin altında ise  
x: If Motor is lower than foot mounting plane  
x:Wen motor ist nidriger den die Anschlußplatte

	63	71	80	90S	90L	100L	112M
k	431	449.5	478	506	531	572	595
k1	-	570	598	631	656	707	730
n	116	138	156	176	176	194	218
n1	97	110	118	126	126	135	146
x	-	-	-	-	-	-	4.5

\* " k1 " Ölçüsü frenli redüktörlere aittir.  
Dimension " k1 " is for motors with brake.  
Maße " k1 " ist für Bremsenmotoren.

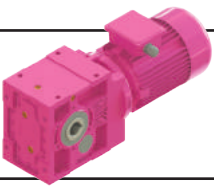

# Ölçü Sayfaları Dimension Pages Abmessungsseiten

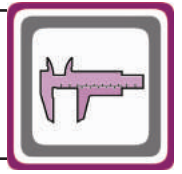

-Mil ucu çektirme deliği DIN 332 sayfa 2 / Tapped center hole to DIN 332, sheet 2 / Zentrierung mit gewinde DIN 332, Blatt 2

## KR273.04

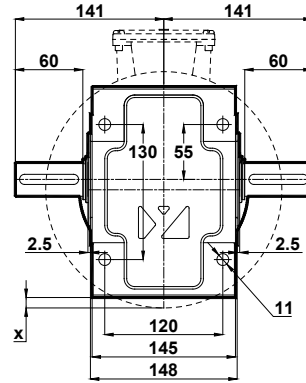
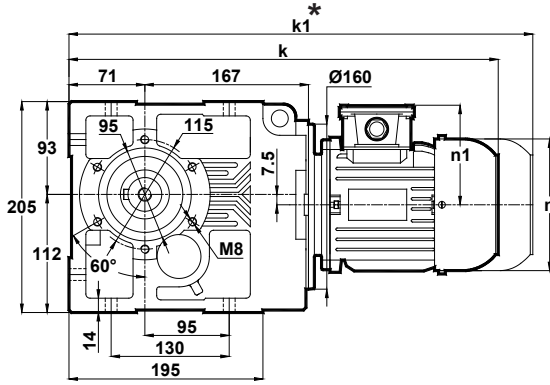

x: Motor Ayak bağlantı yüzeyinin altında ise  
x: If Motor is lower then foot mounting plane  
x: Wenn motor ist niedriger den die Anschlußplatte

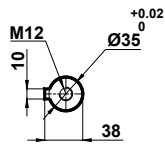

	63	71	80	90S	90L	100L	112M
k	431	449.5	478	506	531	572	595
k1	-	570	598	631	656	707	730
n	116	138	156	176	176	194	218
n1	97	110	118	126	126	135	146
x	-	-	-	-	-	-	4.5

Klemens Pozisyonları  
Terminal Box Positions  
Klemmenkasten Positionen

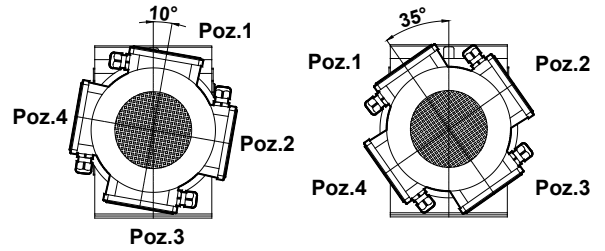

71  
Tip / Type / Typ

63-80-90-100-112  
Tip / Type / Typ

## KR273.05

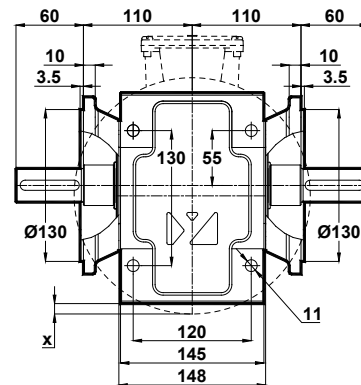
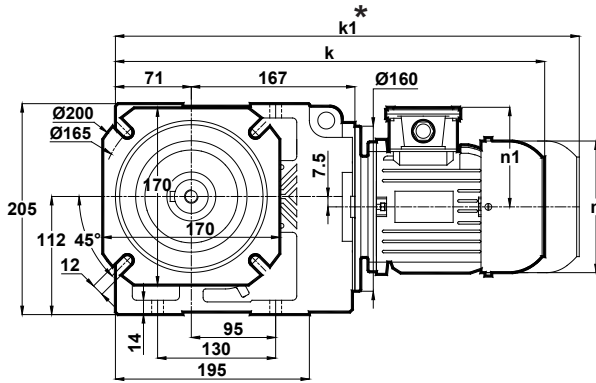

x: Motor Ayak bağlantı yüzeyinin altında ise  
x: If Motor is lower then foot mounting plane  
x: Wenn motor ist niedriger den die Anschlußplatte

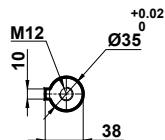

	63	71	80	90S	90L	100L	112M
k	431	449.5	478	506	531	572	595
k1	-	570	598	631	656	707	730
n	116	138	156	176	176	194	218
n1	97	110	118	126	126	135	146
x	-	-	-	-	-	-	4.5

\* " k1 " Ölçüsü frenli redüktörlere aittir.  
Dimension " k1 " is for motors with brake.  
Maße " k1 " ist für Bremsenmotoren.

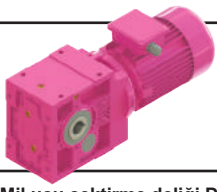

# Ölçü Sayfaları Dimension Pages Abmessungsseiten

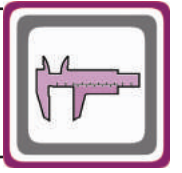

-Mil ucu çektirme deliği DIN 332 sayfa 2 / Tapped center hole to DIN 332, sheet 2 / Zentrierung mit gewinde DIN 332, Blatt 2

KR273.08

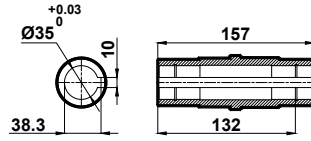
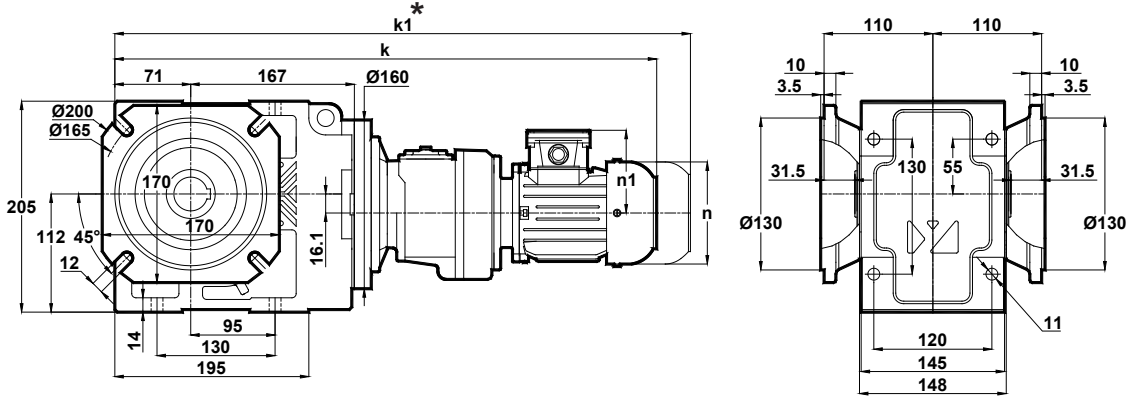

Klemens Pozisyonları  
Terminal Box Positions  
Klemmenkasten Positionen

	63	71	80	90S	90L	100L	112M
k	431	449.5	478	506	531	572	595
k1	-	570	598	631	656	707	730
n	116	138	156	176	176	194	218
n1	97	110	118	126	126	135	146
x	-	-	-	-	-	-	4.5

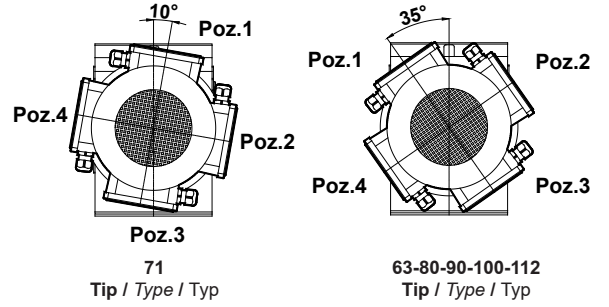

\* " k1 " Ölçüsü frenli redüktörlere aittir.  
Dimension " k1 " is for motors with brake.  
Maße " k1 " ist für Bremsenmotoren.

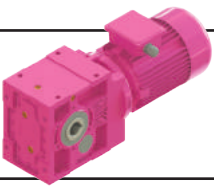

# Ölçü Sayfaları Dimension Pages Abmessungsseiten

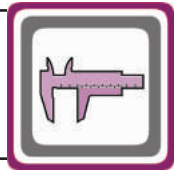

-Mil ucu çekirme deliği DIN 332 sayfa 2 / Tapped center hole to DIN 332, sheet 2 / Zentrierung mit gewinde DIN 332, Blatt 2

KR275.00  
KR276.00

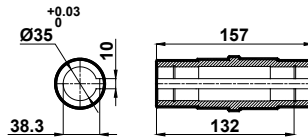
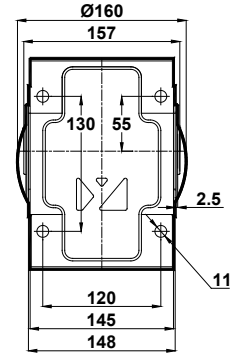
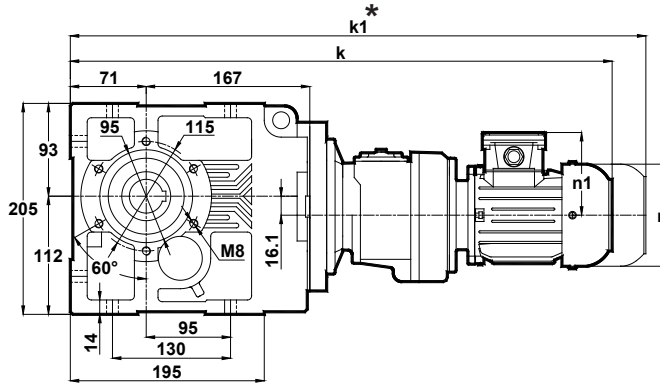

**Klemens Pozisyonları**  
Terminal Box Positions  
Klemmenkasten Positionen

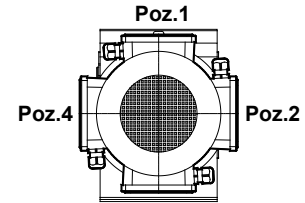

**Poz.3**

63-71-80  
Tip / Type / Typ

	63	71	80
k	581	600	628
k1	-	720	748
n	116	138	156
n1	97	110	118

KR275.01  
KR276.01

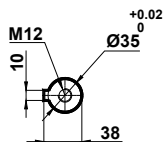
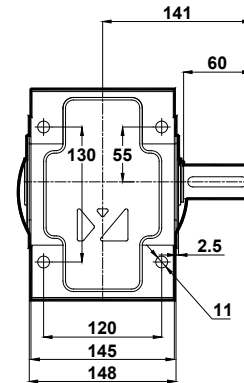
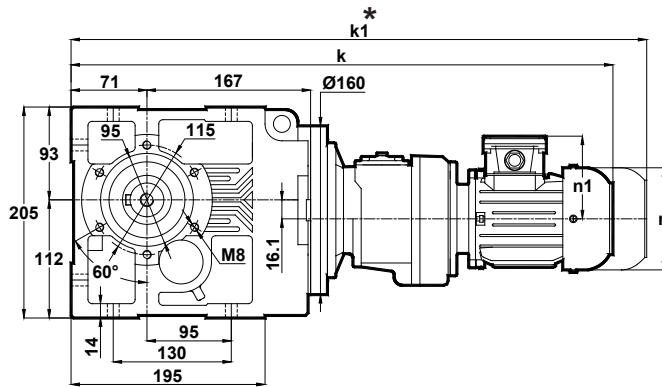

	63	71	80
k	581	600	628
k1	-	720	748
n	116	138	156
n1	97	110	118

\* "k1" Ölçüsü frenli redüktörlere aittir.  
Dimension "k1" is for motors with brake.  
Maße "k1" ist für Bremsenmotoren.

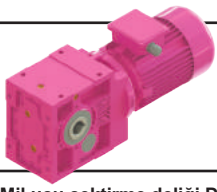

# Ölçü Sayfaları Dimension Pages Abmessungsseiten

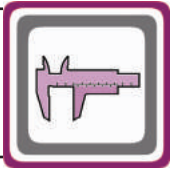

-Mil ucu çektirme deliği DIN 332 sayfa 2 / Tapped center hole to DIN 332, sheet 2 / Zentrierung mit gewinde DIN 332, Blatt 2

KR275.02  
KR276.02

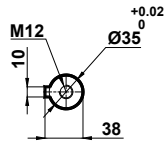
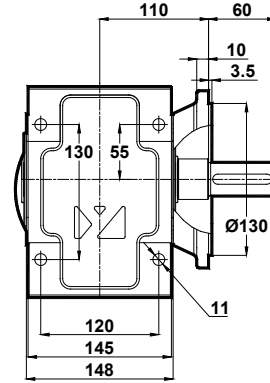
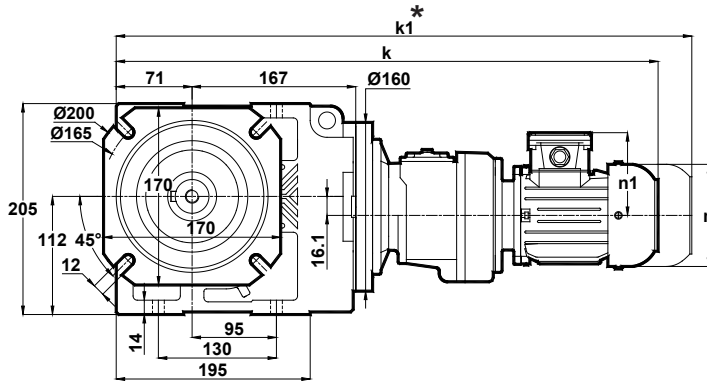

	63	71	80
k	581	600	628
k1	-	720	748
n	116	138	156
n1	97	110	118

Klemens Pozisyonları  
Terminal Box Positions  
Klemmenkasten Positionen

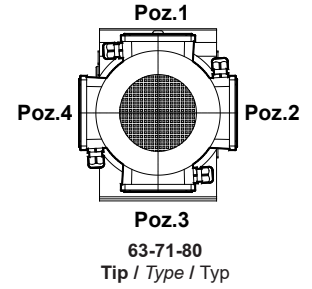

KR275.03  
KR276.03

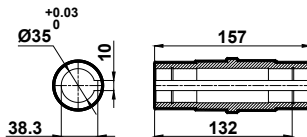
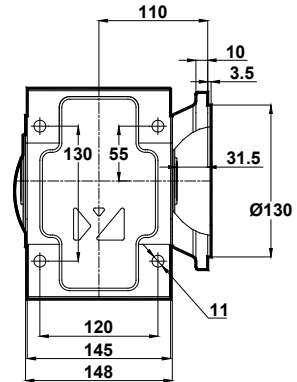
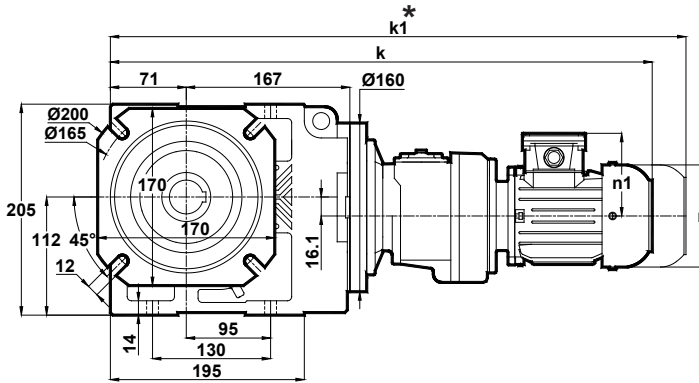

	63	71	80
k	581	600	628
k1	-	720	748
n	116	138	156
n1	97	110	118

\* " k1 " Ölçüsü frenli redüktörlere aittir.  
Dimension " k1 " is for motors with brake.  
Maße " k1 " ist für Bremsenmotoren.

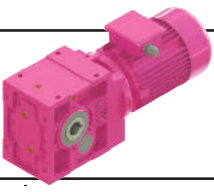

# Ölçü Sayfaları Dimension Pages Abmessungsseiten

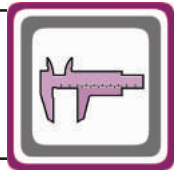

-Mil ucu çektirme deliği DIN 332 sayfa 2 / Tapped center hole to DIN 332, sheet 2 / Zentrierung mit gewinde DIN 332, Blatt 2

KR275.04  
KR276.04

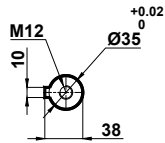
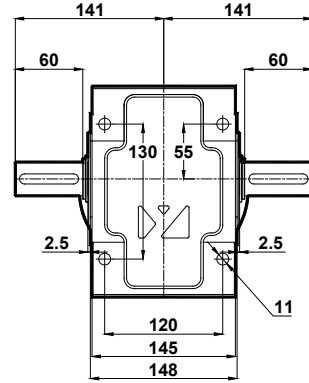
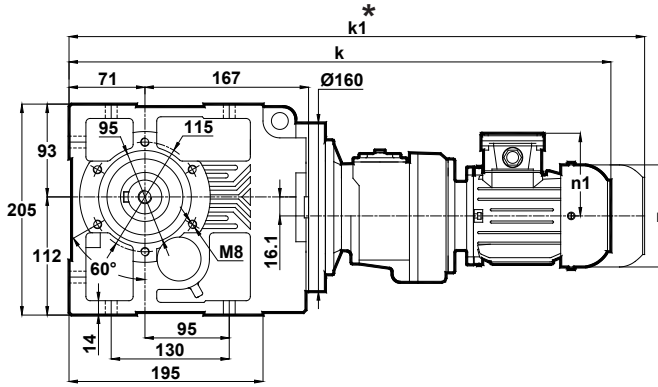

	63	71	80
k	581	600	628
k1	-	720	748
n	116	138	156
n1	97	110	118

Klemens Pozisyonları  
Terminal Box Positions  
Klemmenkasten Positionen

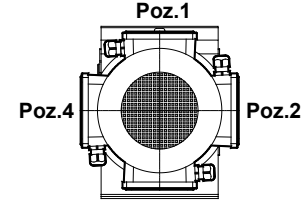

Poz.3  
63-71-80  
Tip / Type / Typ

KR275.05  
KR276.05

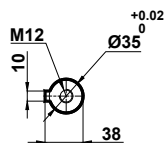
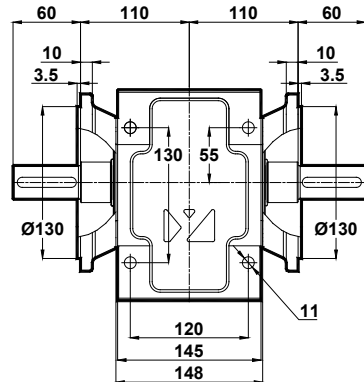
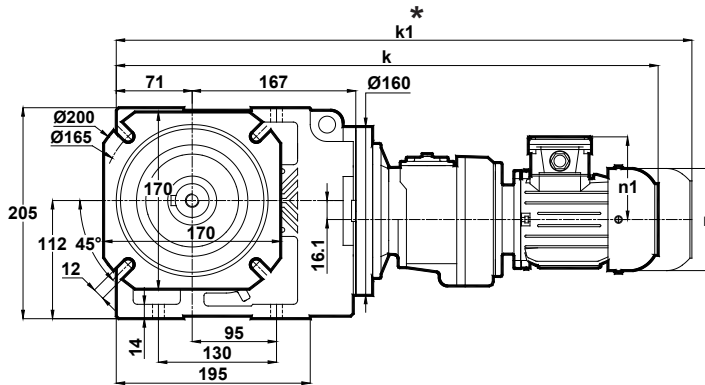

	63	71	80
k	581	600	628
k1	-	720	748
n	116	138	156
n1	97	110	118

\* "k1" Ölçüsü frenli redüktörlere aittir.  
Dimension "k1" is for motors with brake.  
Maße "k1" ist für Bremsenmotoren.

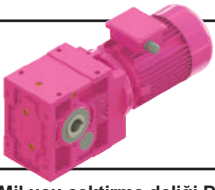

# Ölçü Sayfaları Dimension Pages Abmessungsseiten

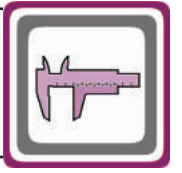

-Mil ucu çektirme deliği DIN 332 sayfa 2 / Tapped center hole to DIN 332, sheet 2 / Zentrierung mit gewinde DIN 332, Blatt 2

KR275.08  
KR276.08

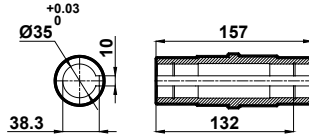
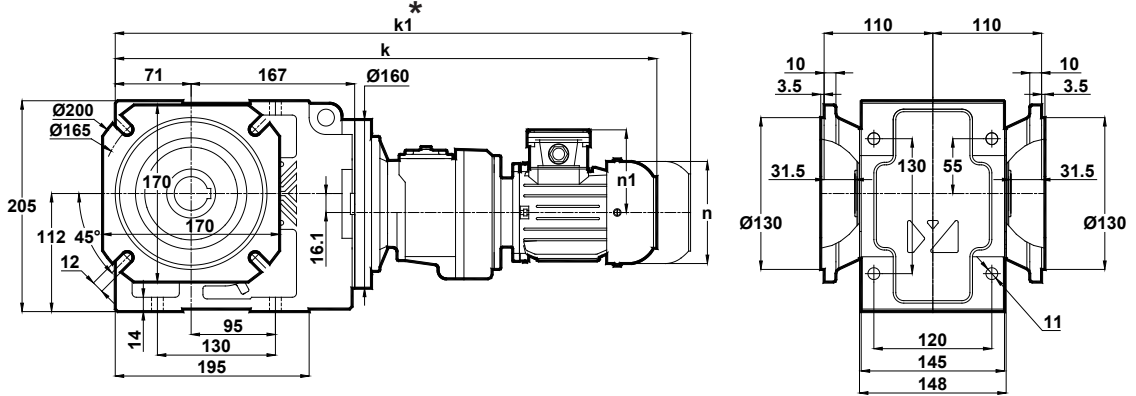

	63	71	80
k	581	600	628
k1	-	720	748
n	116	138	156
n1	97	110	118

**Klemens Pozisyonları**  
Terminal Box Positions  
Klemmenkasten Positionen

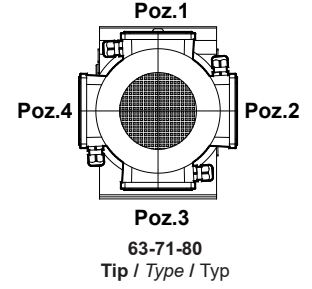

\* " k1 " Ölçüsü frenli redüktörlere aittir.  
Dimension " k1 " is for motors with brake.  
Maße " k1 " ist für Bremsenmotoren.

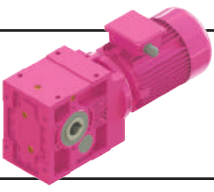

# Ölçü Sayfaları Dimension Pages Abmessungsseiten

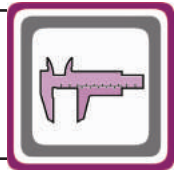

-Mil ucu çektirme deliği DIN 332 sayfa 2 / Tapped center hole to DIN 332, sheet 2 / Zentrierung mit gewinde DIN 332, Blatt 2

## KR373.00

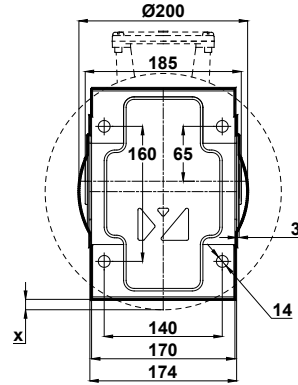
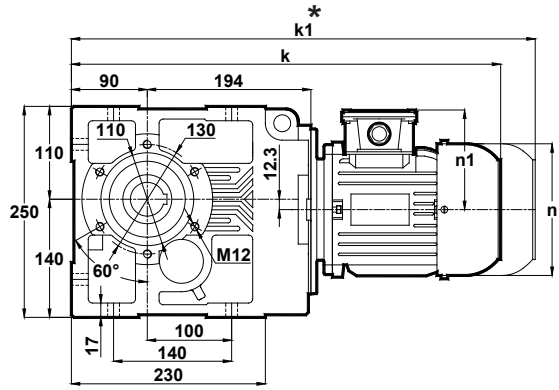

**Std.**

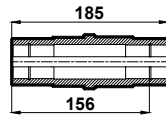
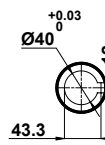

**Ops.**

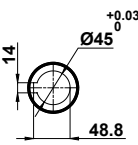

x: Motor Ayak bağlantı yüzeyinin altında ise  
x: If Motor is lower then foot mounting plane  
x:Wen motor ist nidriger den die Anschlußplatte

**Klemens Pozisyonları**  
Terminal Box Positions  
Klemmenkasten Positionen

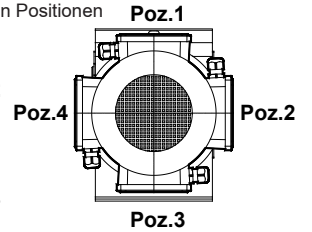
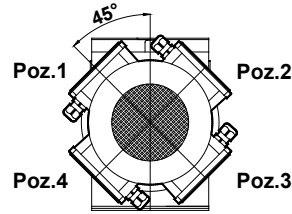

71-100-112-132  
Tip / Type / Typ

80-90  
Tip / Type / Typ

	71	80	90S	90L	100L	112M	132S	132M
k	487	515	544	569	609	632	686	724
k1	607	635	669	694	744	767	831	869
n	138	156	176	176	194	218	258	258
n1	110	118	126	126	135	146	168	168
x	-	-	-	-	-	-	1.3	1.3

## KR373.01

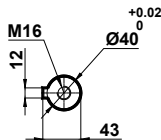
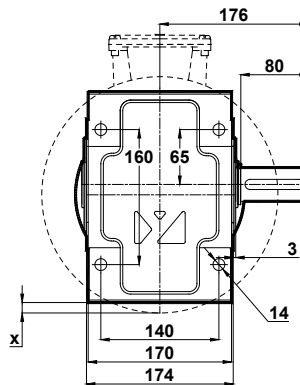
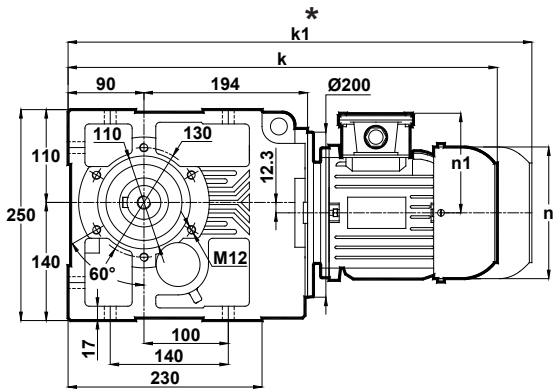

x: Motor Ayak bağlantı yüzeyinin altında ise  
x: If Motor is lower then foot mounting plane  
x:Wen motor ist nidriger den die Anschlußplatte

	71	80	90S	90L	100L	112M	132S	132M
k	487	515	544	569	609	632	686	724
k1	607	635	669	694	744	767	831	869
n	138	156	176	176	194	218	258	258
n1	110	118	126	126	135	146	168	168
x	-	-	-	-	-	-	1.3	1.3

\* " k1 " Ölçüsü frenli redüktörlere aittir.  
Dimension " k1 " is for motors with brake.  
Maße " k1 " ist für Bremsmotoren.

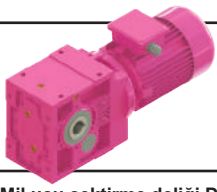

# Ölçü Sayfaları Dimension Pages Abmessungsseiten

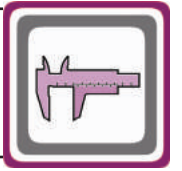

-Mil ucu çektirme deliği DIN 332 sayfa 2 / Tapped center hole to DIN 332, sheet 2 / Zentrierung mit gewinde DIN 332, Blatt 2

## KR373.02

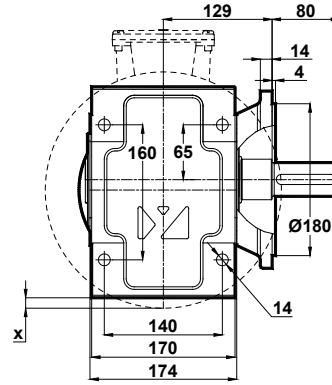
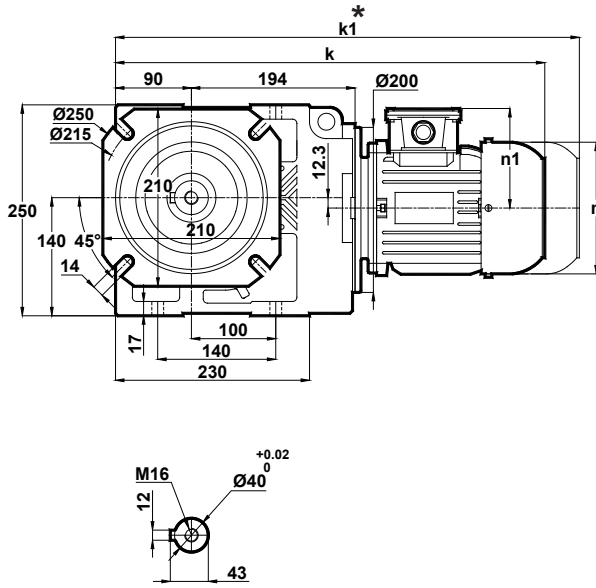

x: Motor Ayak bağlantı yüzeyinin altında ise  
x: If Motor is lower than foot mounting plane  
x: Wenn motor ist niedriger den die Anschlußplatte

	71	80	90S	90L	100L	112M	132S	132M
k	487	515	544	569	609	632	686	724
k1	607	635	669	694	744	767	831	869
n	138	156	176	176	194	218	258	258
n1	110	118	126	126	135	146	168	168
x	-	-	-	-	-	-	1.3	1.3

Klemens Pozisyonları  
Terminal Box Positions  
Klemmenkasten Positionen

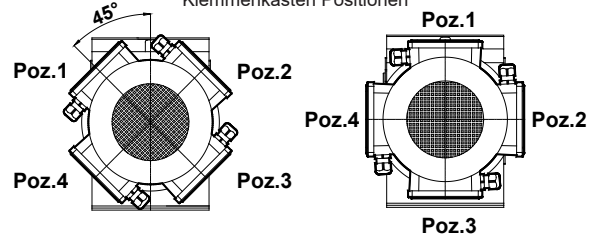

71-100-112-132  
Tip / Type / Typ

80-90  
Tip / Type / Typ

## KR373.03

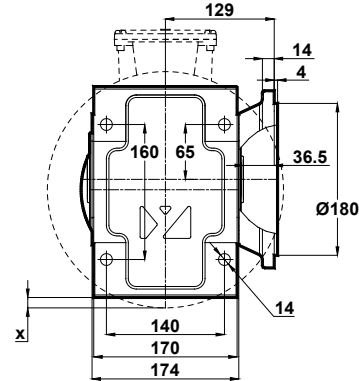
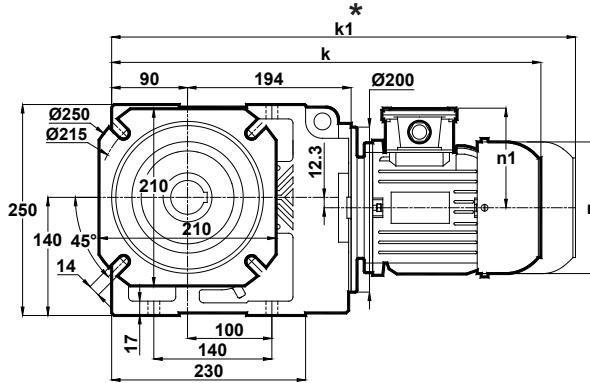

Std.

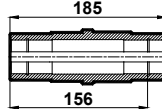
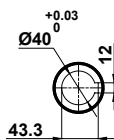

Ops.

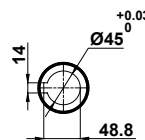

x: Motor Ayak bağlantı yüzeyinin altında ise  
x: If Motor is lower than foot mounting plane  
x: Wenn motor ist niedriger den die Anschlußplatte

	71	80	90S	90L	100L	112M	132S	132M
k	487	515	544	569	609	632	686	724
k1	607	635	669	694	744	767	831	869
n	138	156	176	176	194	218	258	258
n1	110	118	126	126	135	146	168	168
x	-	-	-	-	-	-	1.3	1.3

\* "k1" Ölçüsü frenli redüktörlere aittir.  
Dimension "k1" is for motors with brake.  
Maße "k1" ist für Bremsenmotoren.

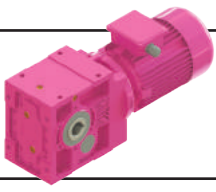

# Ölçü Sayfaları Dimension Pages Abmessungsseiten

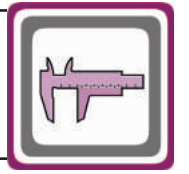

-Mil ucu çektirme deliği DIN 332 sayfa 2 / Tapped center hole to DIN 332, sheet 2 / Zentrierung mit gewinde DIN 332, Blatt 2

## KR373.04

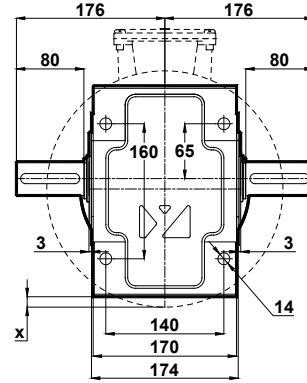
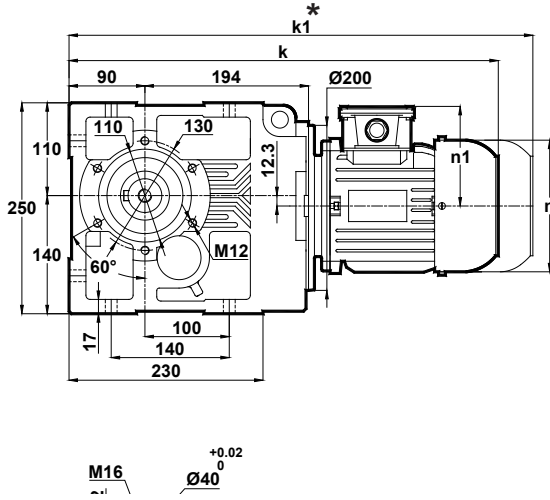

x: Motor Ayak bağlantı yüzeyinin altında ise  
x: If Motor is lower then foot mounting plane  
x: Wenn motor ist niedriger den die Anschlußplatte

	71	80	90S	90L	100L	112M	132S	132M
k	487	515	544	569	609	632	686	724
k1	607	635	669	694	744	767	831	869
n	138	156	176	176	194	218	258	258
n1	110	118	126	126	135	146	168	168
x	-	-	-	-	-	-	1.3	1.3

### Klemens Pozisyonları Terminal Box Positions Klemmenkasten Positionen

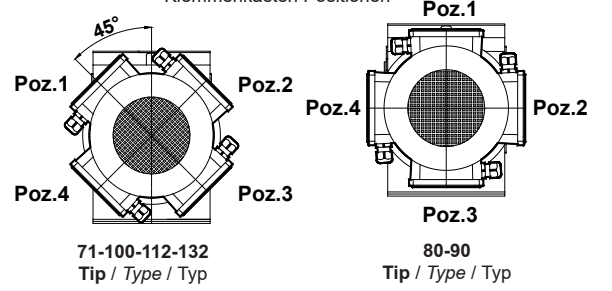

## KR373.05

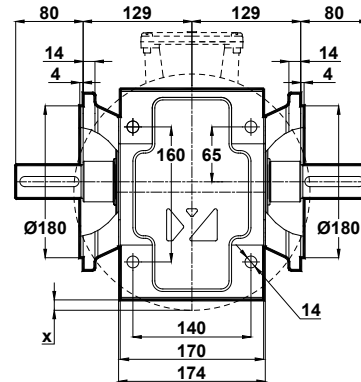
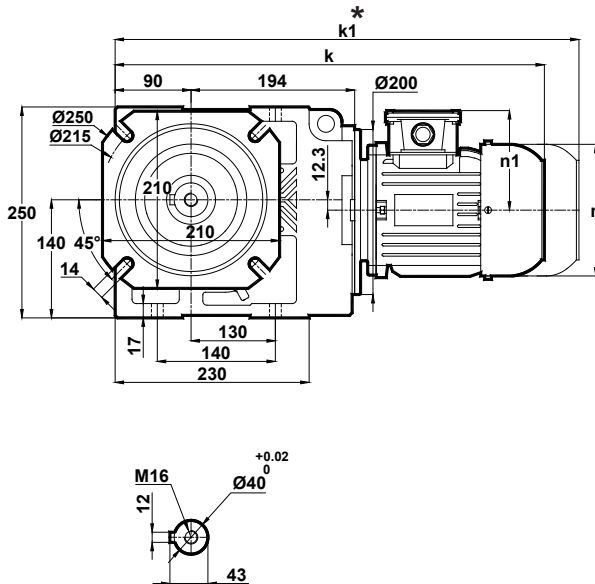

x: Motor Ayak bağlantı yüzeyinin altında ise  
x: If Motor is lower then foot mounting plane  
x: Wenn motor ist niedriger den die Anschlußplatte

	71	80	90S	90L	100L	112M	132S	132M
k	487	515	544	569	609	632	686	724
k1	607	635	669	694	744	767	831	869
n	138	156	176	176	194	218	258	258
n1	110	118	126	126	135	146	168	168
x	-	-	-	-	-	-	1.3	1.3

\* "k1" Ölçüsü frenli redüktörlere aittir.  
Dimension "k1" is for motors with brake.  
Maße "k1" ist für Bremsenmotoren.

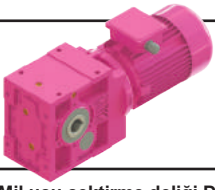

# Ölçü Sayfaları

## Dimension Pages

### Abmessungsseiten

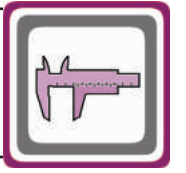

-Mil ucu çekirme deliği DIN 332 sayfa 2 / Tapped center hole to DIN 332, sheet 2 / Zentrierung mit gewinde DIN 332, Blatt 2

KR373.08

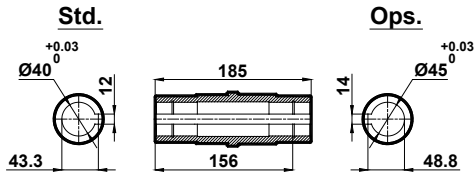
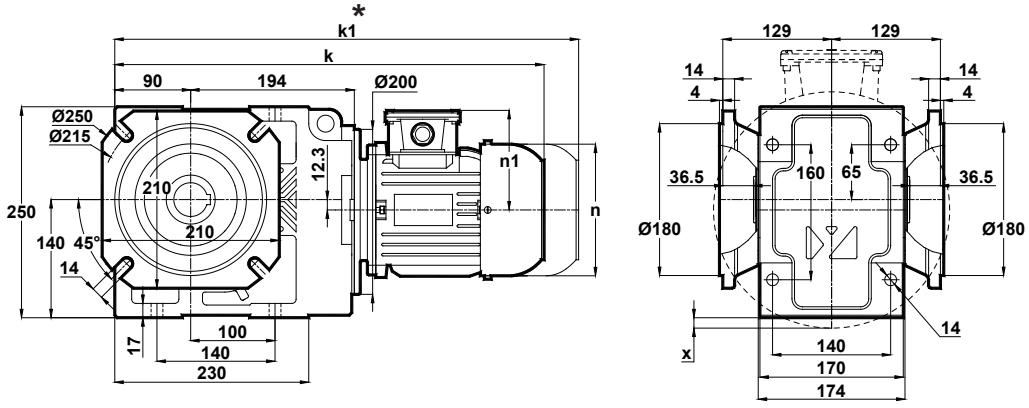

x: Motor Ayak bağlantı yüzeyinin altında ise  
x: If Motor is lower then foot mounting plane  
x: Wenn motor ist niedriger den die Anschlussplatte

	71	80	90S	90L	100L	112M	132S	132M
k	487	515	544	569	609	632	686	724
k1	607	635	669	694	744	767	831	869
n	138	156	176	176	194	218	258	258
n1	110	118	126	126	135	146	168	168
x	-	-	-	-	-	-	1.3	1.3

Klemens Pozisyonları  
Terminal Box Positions  
Klemmenkasten Positionen

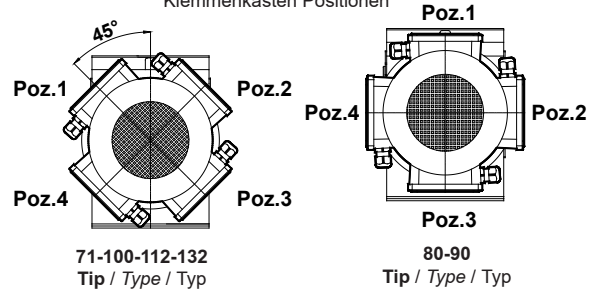

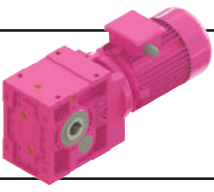

# Ölçü Sayfaları

## Dimension Pages

### Abmessungsseiten

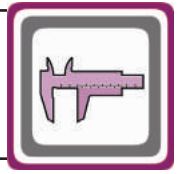

-Mil ucu çekirme deliği DIN 332 sayfa 2 / Tapped center hole to DIN 332, sheet 2 / Zentrierung mit gewinde DIN 332, Blatt 2

#### KR374.00

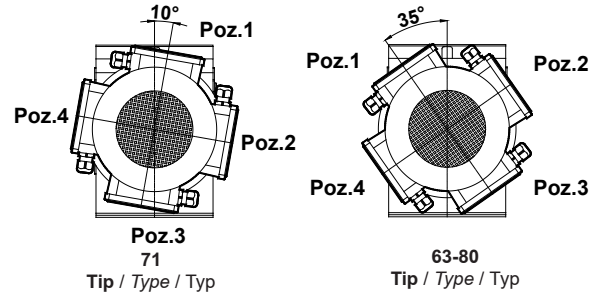
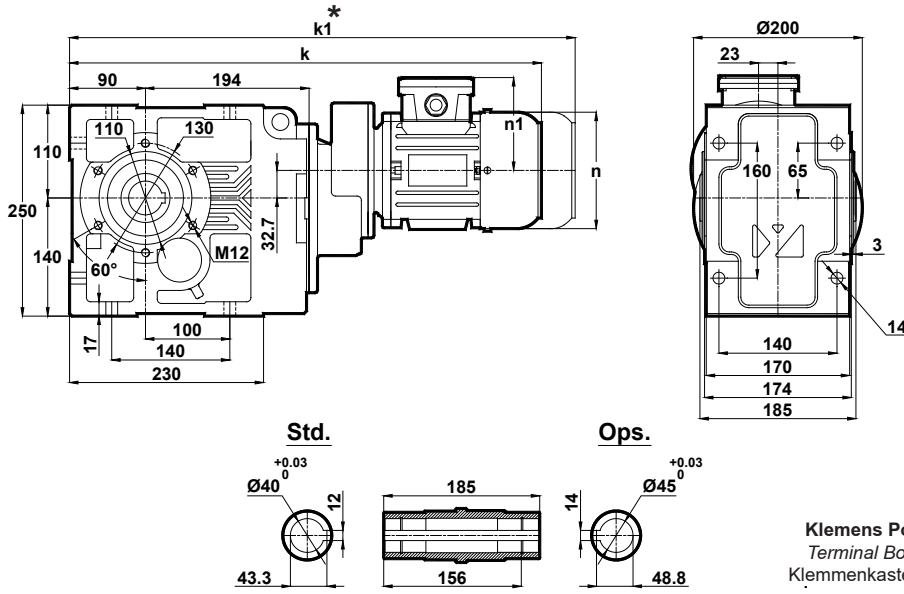

#### KR374.01

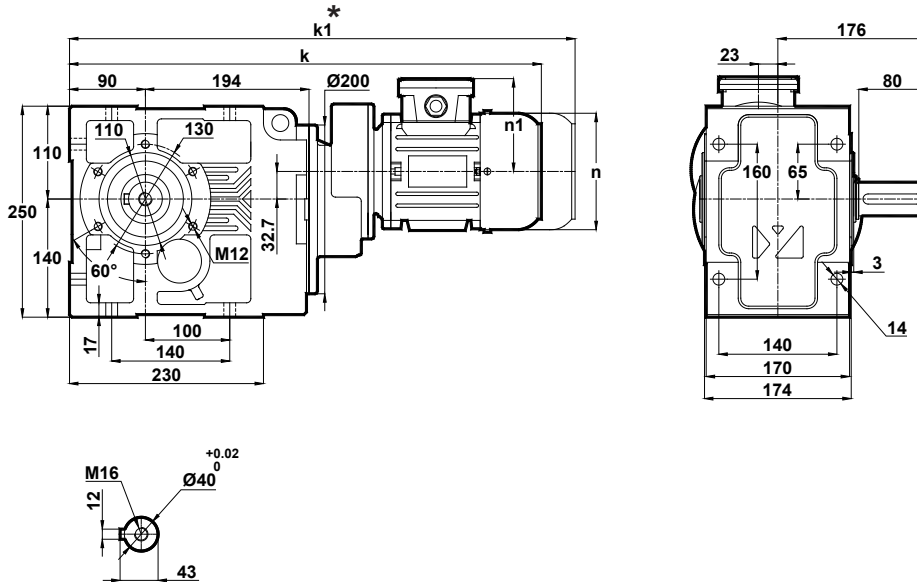

	63	71	80
k	547	566	594
k1	-	686	714
n	116	138	156
n1	97	110	118

\* " k1 " Ölçüsü frenli redüktörlere aittir.  
Dimension " k1 " is for motors with brake.  
Maße " k1 " ist für Bremsenmotoren.

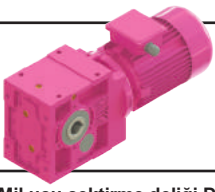

# Ölçü Sayfaları Dimension Pages Abmessungsseiten

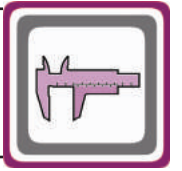

-Mil ucu çektirme deliği DIN 332 sayfa 2 / Tapped center hole to DIN 332, sheet 2 / Zentrierung mit gewinde DIN 332, Blatt 2

## KR374.02

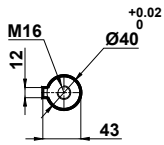
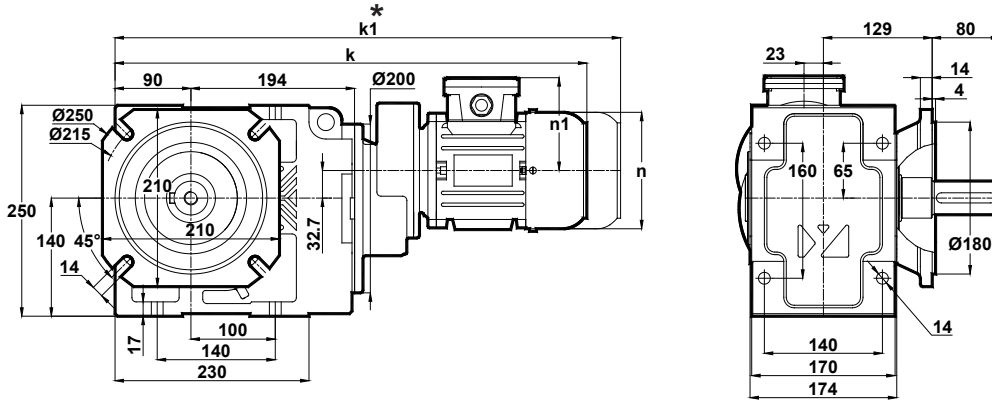

	63	71	80
k	547	566	594
k1	-	686	714
n	116	138	156
n1	97	110	118

Klemens Pozisyonları  
Terminal Box Positions  
Klemmenkasten Positionen

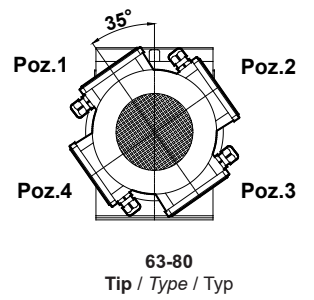
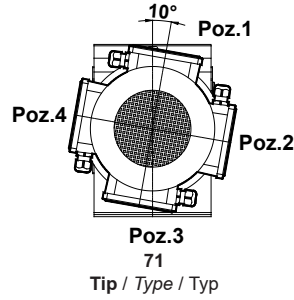

## KR374.03

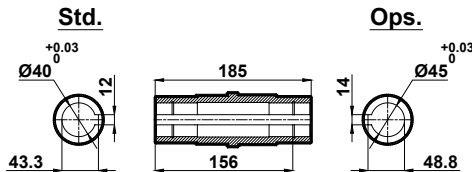
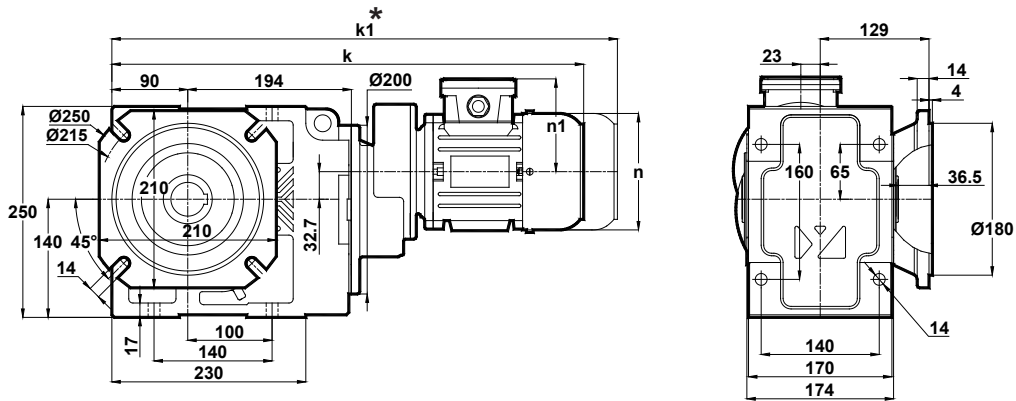

	63	71	80
k	547	566	594
k1	-	686	714
n	116	138	156
n1	97	110	118

\* " k1 " Ölçüsü frenli redüktörlere aittir.  
Dimension " k1 " is for motors with brake.  
Maße " k1 " ist für Bremsenmotoren.

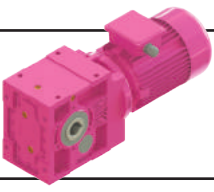

# Ölçü Sayfaları Dimension Pages Abmessungsseiten

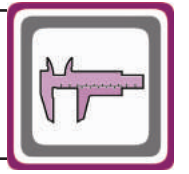

-Mil ucu çektirme deliği DIN 332 sayfa 2 / Tapped center hole to DIN 332, sheet 2 / Zentrierung mit gewinde DIN 332, Blatt 2

## KR374.04

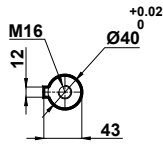
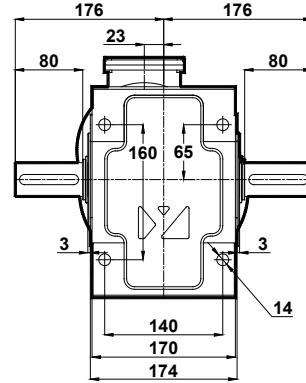
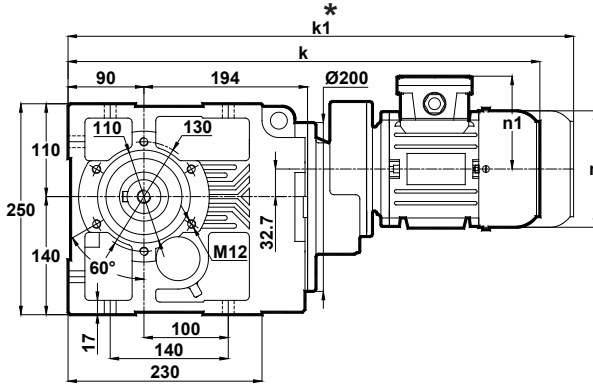

	63	71	80
k	547	566	594
k1	-	686	714
n	116	138	156
n1	97	110	118

Klemens Pozisyonları  
Terminal Box Positions  
Klemmenkasten Positionen

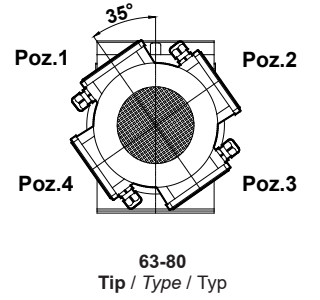
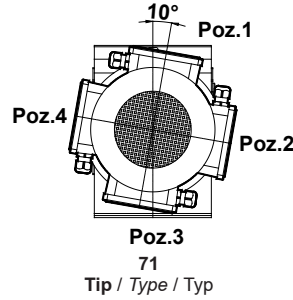

## KR374.05

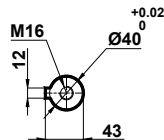
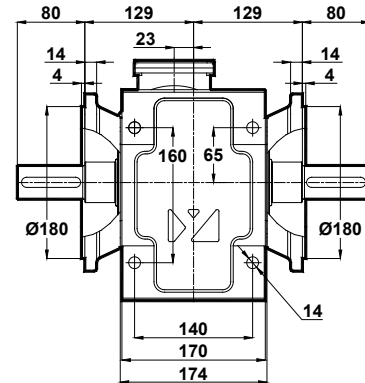
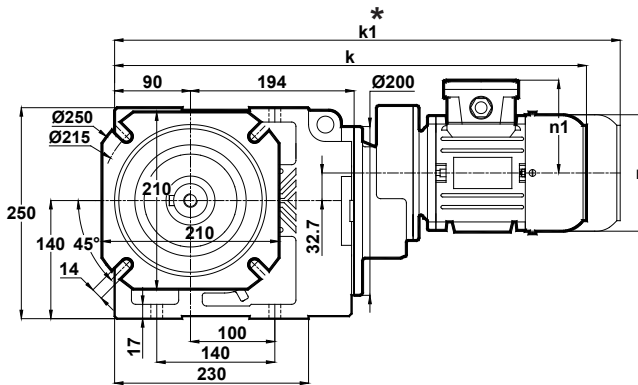

	63	71	80
k	547	566	594
k1	-	686	714
n	116	138	156
n1	97	110	118

\* "k1" Ölçüsü frenli redüktörlere aittir.  
Dimension "k1" is for motors with brake.  
Maße "k1" ist für Bremsmotoren.

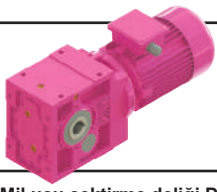

# Ölçü Sayfaları Dimension Pages Abmessungsseiten

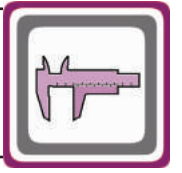

-Mil ucu çektirme deliği DIN 332 sayfa 2 / Tapped center hole to DIN 332, sheet 2 / Zentrierung mit gewinde DIN 332, Blatt 2

KR374.08

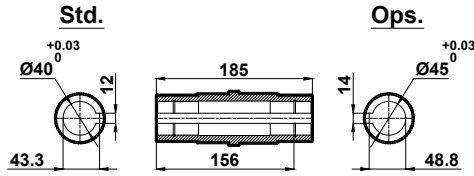
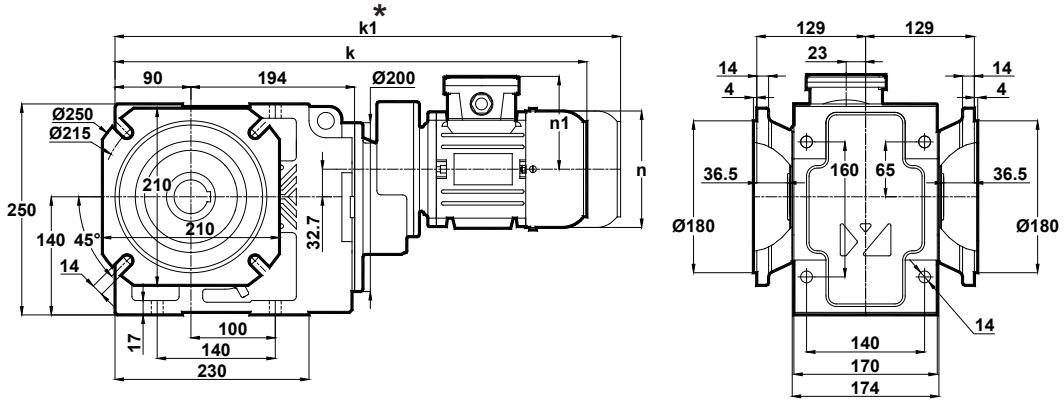

Klemens Pozisyonları  
Terminal Box Positions  
Klemmenkasten Positionen

	63	71	80
k	547	566	594
k1	-	686	714
n	116	138	156
n1	97	110	118

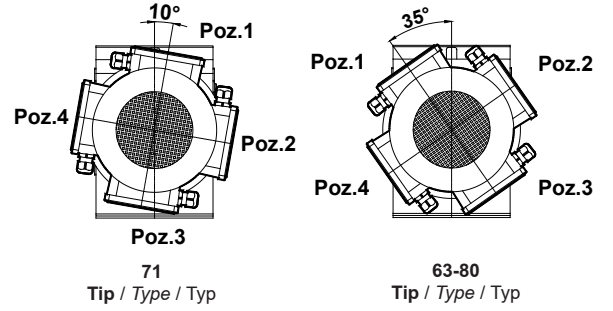

\* " k1 " Ölçüsü frenli redüktörlere aittir.  
Dimension " k1 " is for motors with brake.  
Maße " k1 " ist für Bremsenmotoren.

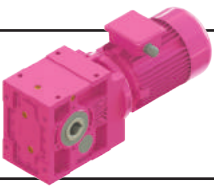

# Ölçü Sayfaları Dimension Pages Abmessungsseiten

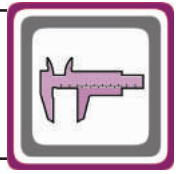

-Mil ucu çektirme deliği DIN 332 sayfa 2 / Tapped center hole to DIN 332, sheet 2 / Zentrierung mit gewinde DIN 332, Blatt 2

KR375.00  
KR376.00

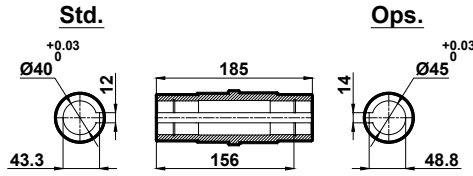
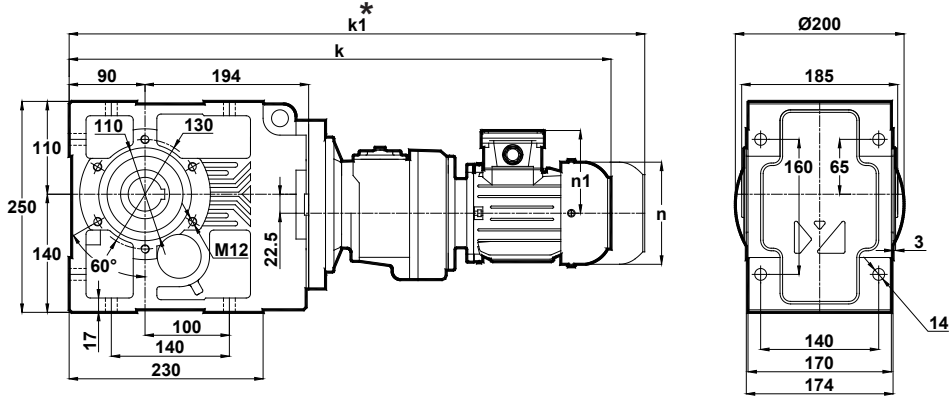

Klemens Pozisyonları  
Terminal Box Positions  
Klemmenkasten Positionen

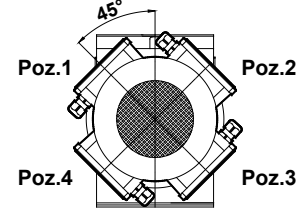

63-71  
Tip / Type / Typ

	63	71
k	647	666
k1	-	786
n	116	138
n1	97	110

KR375.01  
KR376.01

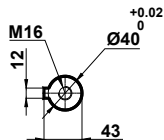
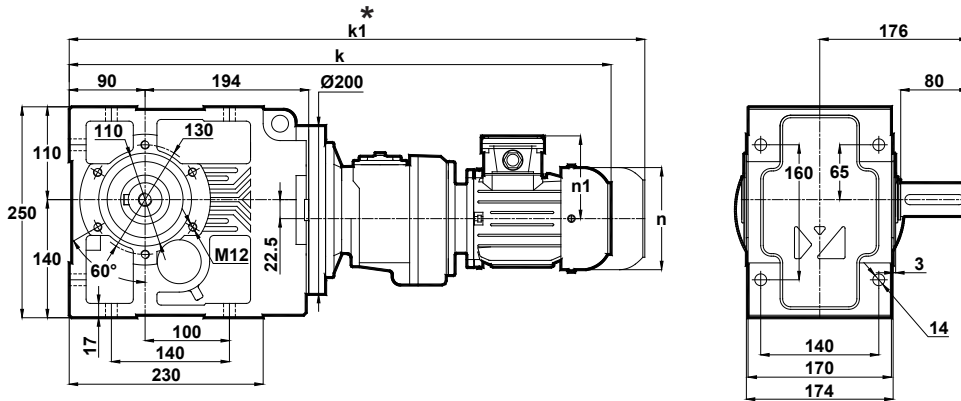

	63	71
k	647	666
k1	-	786
n	116	138
n1	97	110

\* "k1" Ölçüsü frenli redüktörlere aittir.  
Dimension "k1" is for motors with brake.  
Maße "k1" ist für Bremsenmotoren.

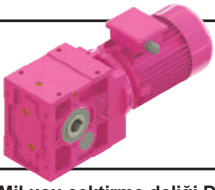

# Ölçü Sayfaları Dimension Pages Abmessungsseiten

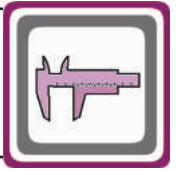

-Mil ucu çektirme deliği DIN 332 sayfa 2 / Tapped center hole to DIN 332, sheet 2 / Zentrierung mit gewinde DIN 332, Blatt 2

KR375.02  
KR376.02

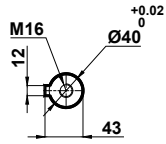
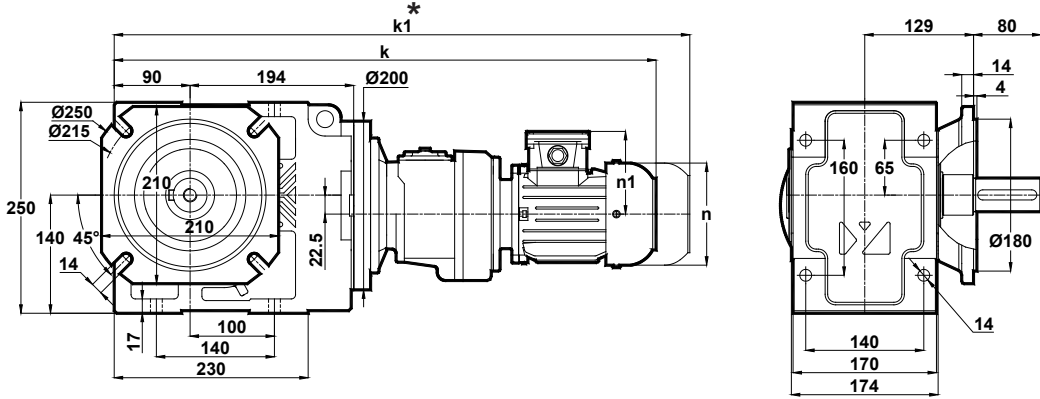

	63	71
k	647	666
k1	-	786
n	116	138
n1	97	110

Klemens Pozisyonları  
Terminal Box Positions  
Klemmenkasten Positionen

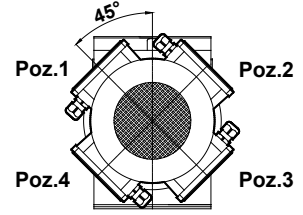

63-71  
Tip / Type / Typ

KR375.03  
KR376.03

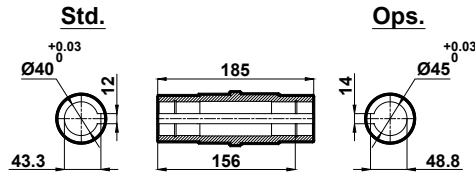
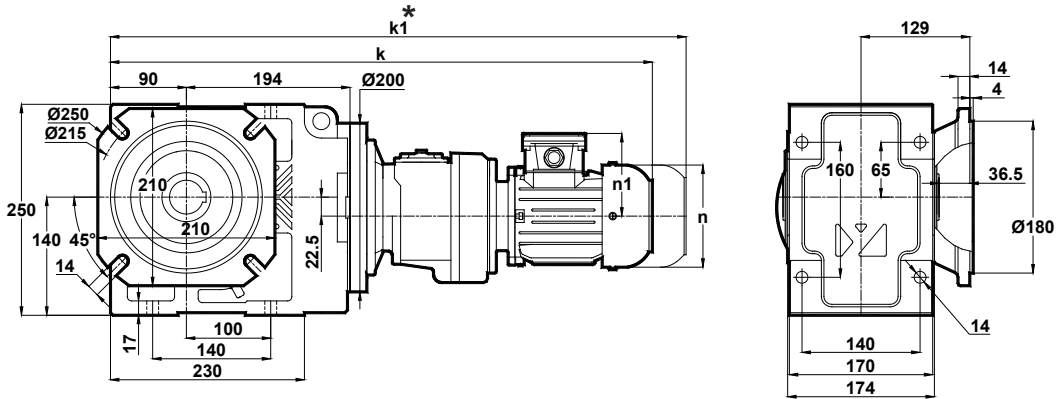

	63	71
k	647	666
k1	-	786
n	116	138
n1	97	110

\* " k1 " Ölçüsü frenli redüktörlere aittir.  
Dimension " k1 " is for motors with brake.  
Maße " k1 " ist für Bremsenmotoren.

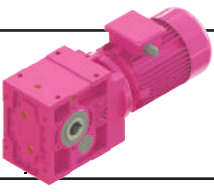

# Ölçü Sayfaları Dimension Pages Abmessungsseiten

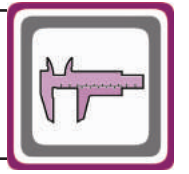

-Mil ucu çekirme deliği DIN 332 sayfa 2 / Tapped center hole to DIN 332, sheet 2 / Zentrierung mit gewinde DIN 332, Blatt 2

KR375.04  
KR376.04

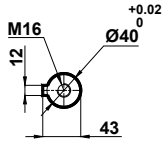
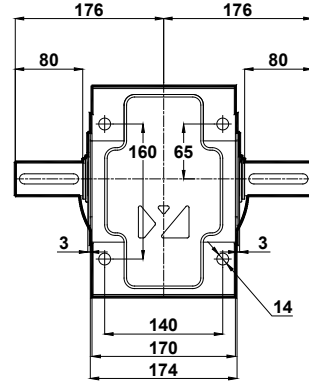
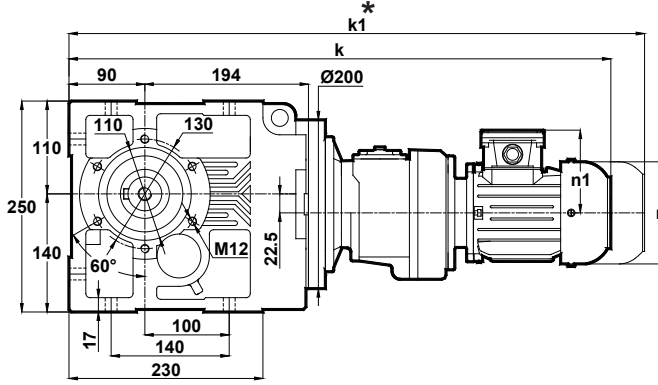

	63	71
k	647	666
k1	-	786
n	116	138
n1	97	110

Klemens Pozisyonları  
Terminal Box Positions  
Klemmenkasten Positionen

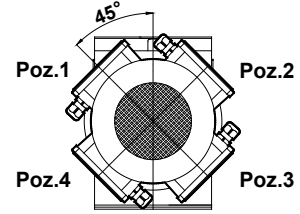

63-71  
Tip / Type / Typ

KR375.05  
KR376.05

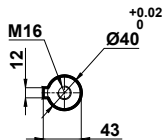
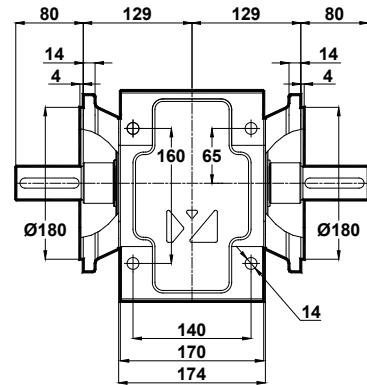
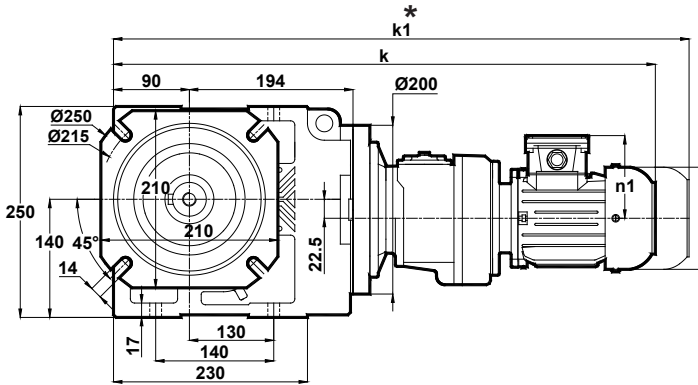

	63	71
k	647	666
k1	-	786
n	116	138
n1	97	110

\* "k1" Ölçüsü frenli redüktörlere aittir.  
Dimension "k1" is for motors with brake.  
Maße "k1" ist für Bremsenmotoren.

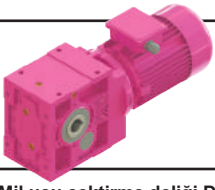

# Ölçü Sayfaları Dimension Pages Abmessungsseiten

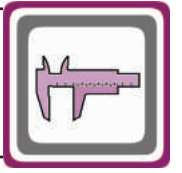

-Mil ucu çektirme deliği DIN 332 sayfa 2 / Tapped center hole to DIN 332, sheet 2 / Zentrierung mit gewinde DIN 332, Blatt 2

KR375.08  
KR376.08

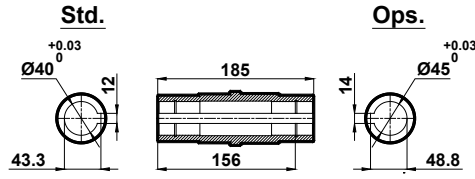
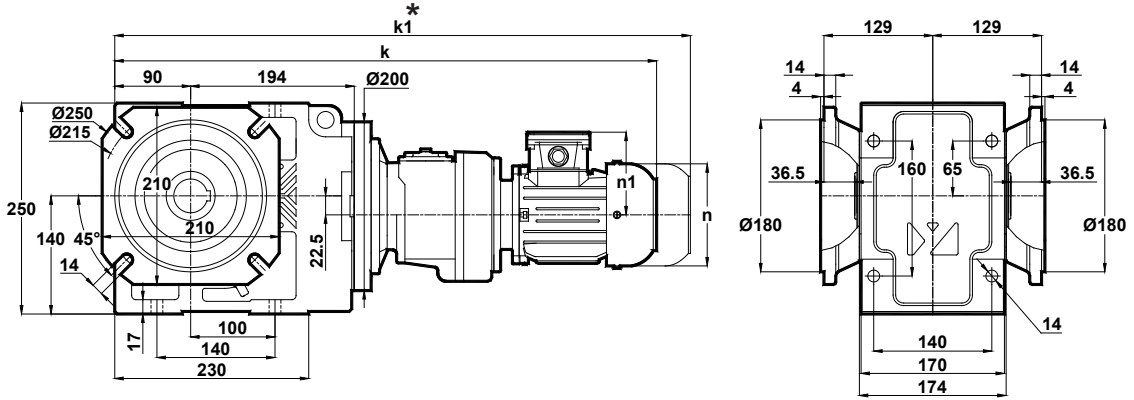

Klemens Pozisyonları  
Terminal Box Positions  
Klemmenkasten Positionen

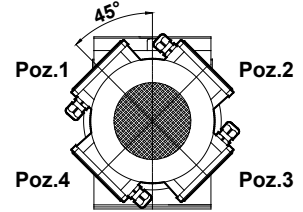

63-71  
Tip / Type / Typ

	63	71
k	647	666
k1	-	786
n	116	138
n1	97	110

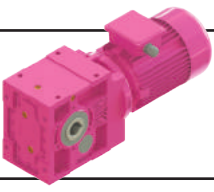

# Ölçü Sayfaları

## Dimension Pages

### Abmessungsseiten

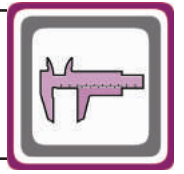

-Mil ucu çekirme deliği DIN 332 sayfa 2 / Tapped center hole to DIN 332, sheet 2 / Zentrierung mit gewinde DIN 332, Blatt 2

#### KR473.00

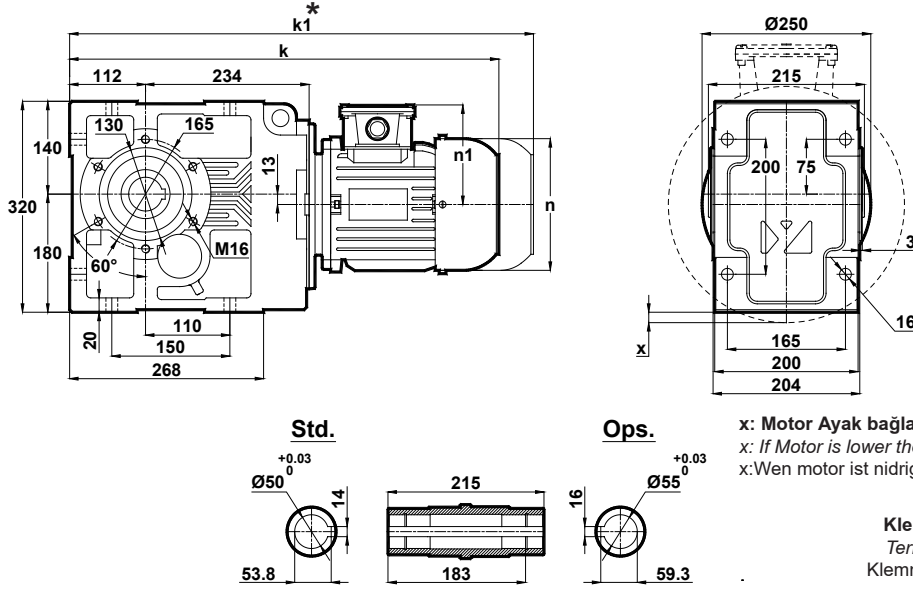

**Klemens Pozisyonları**  
Terminal Box Positions  
Klemmenkasten Positionen

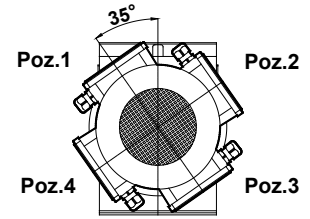

80-90-100-112-132-160-180  
Tip / Type / Typ

	80	90S	90L	100L	112M	132S	132M	160M	160L	180M	180L
k	572	600	625	663	689	738	776	851	895	912	950
k1	692	725	750	798	824	883	921	1021	1065	1082	1120
n	156	176	176	194	218	258	258	310	310	348	348
n1	118	126	126	135	146	168	168	225	225	241	241
x	-	-	-	-	-	-	-	-	-	7	7

#### KR473.01

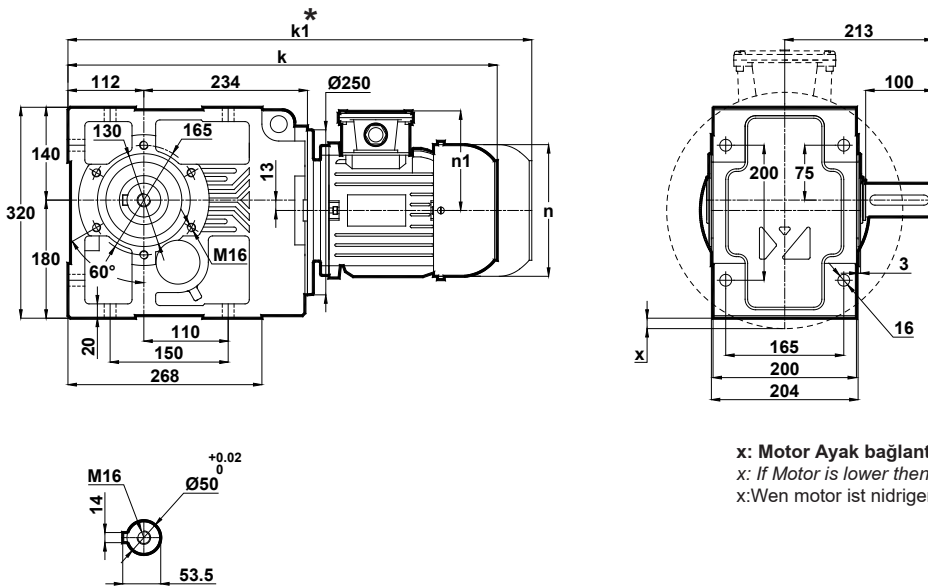

	80	90S	90L	100L	112M	132S	132M	160M	160L	180M	180L
k	572	600	625	663	689	738	776	851	895	912	950
k1	692	725	750	798	824	883	921	1021	1065	1082	1120
n	156	176	176	194	218	258	258	310	310	348	348
n1	118	126	126	135	146	168	168	225	225	241	241
x	-	-	-	-	-	-	-	-	-	7	7

\* "k1" Ölçüsü frenli redüktörlere aittir.  
Dimension "k1" is for motors with brake.  
Maße "k1" ist für Bremsenmotoren.

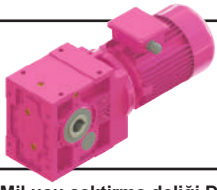

# Ölçü Sayfaları Dimension Pages Abmessungsseiten

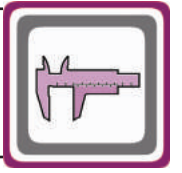

-Mil ucu çektirme deliği DIN 332 sayfa 2 / Tapped center hole to DIN 332, sheet 2 / Zentrierung mit gewinde DIN 332, Blatt 2

## KR473.02

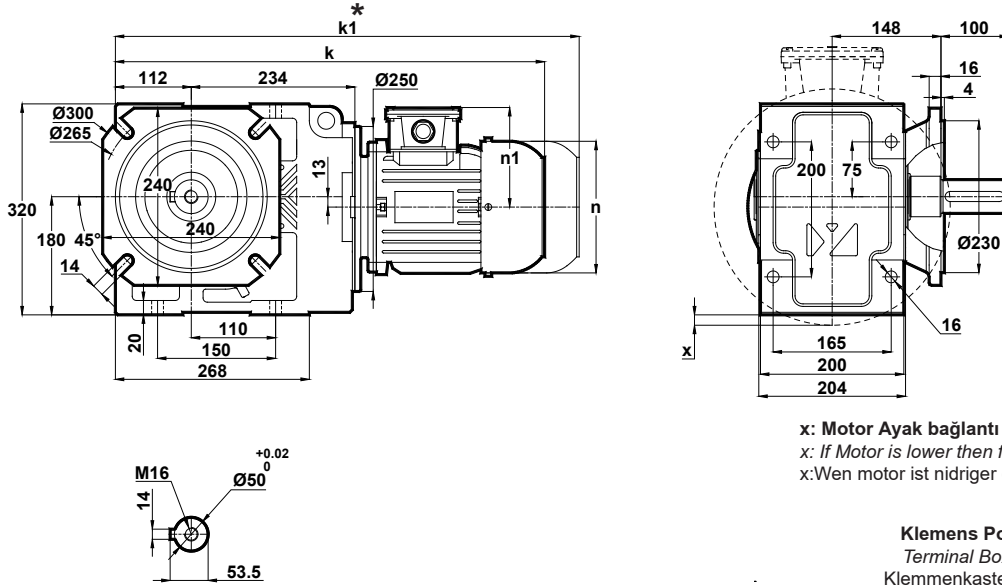

x: Motor Ayak bağlantı yüzeyinin altında ise  
x: If Motor is lower then foot mounting plane  
x: Wenn motor ist niedriger den die Anschlußplatte

Klemens Pozisyonları  
Terminal Box Positions  
Klemmenkasten Positionen

	80	90S	90L	100L	112M	132S	132M	160M	160L	180M	180L
k	572	600	625	663	689	738	776	851	895	912	950
k1	692	725	750	798	824	883	921	1021	1065	1082	1120
n	156	176	176	194	218	258	258	310	310	348	348
n1	118	126	126	135	146	168	168	225	225	241	241
x	-	-	-	-	-	-	-	-	-	7	7

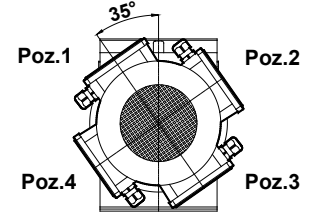

80-90-100-112-132-160-180  
Tip / Type / Typ

## KR473.03

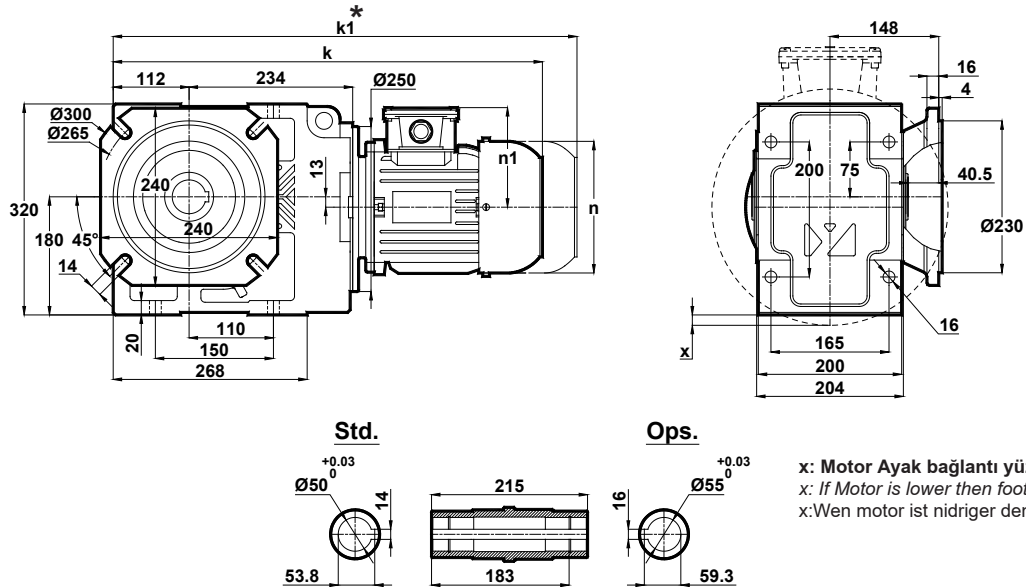

x: Motor Ayak bağlantı yüzeyinin altında ise  
x: If Motor is lower then foot mounting plane  
x: Wenn motor ist niedriger den die Anschlußplatte

	80	90S	90L	100L	112M	132S	132M	160M	160L	180M	180L
k	572	600	625	663	689	738	776	851	895	912	950
k1	692	725	750	798	824	883	921	1021	1065	1082	1120
n	156	176	176	194	218	258	258	310	310	348	348
n1	118	126	126	135	146	168	168	225	225	241	241
x	-	-	-	-	-	-	-	-	-	7	7

\* " k1 " Ölçüsü frenli redüktörlere aittir.  
Dimension " k1 " is for motors with brake.  
Maße " k1 " ist für Bremsenmotoren.

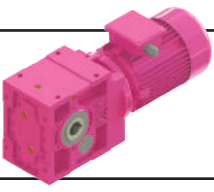

# Ölçü Sayfaları Dimension Pages Abmessungsseiten

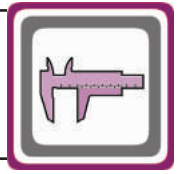

-Mil ucu çekirme deliği DIN 332 sayfa 2 / Tapped center hole to DIN 332, sheet 2 / Zentrierung mit gewinde DIN 332, Blatt 2

## KR473.04

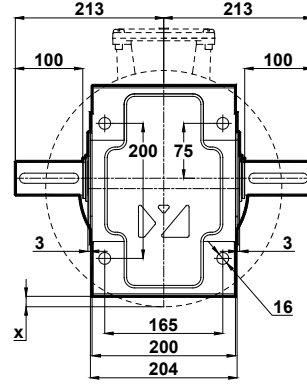
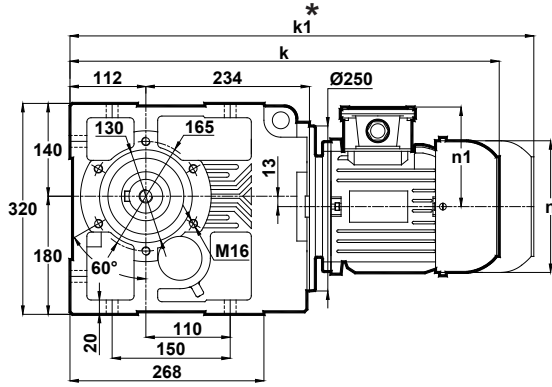

x: Motor Ayak bağlantı yüzeyinin altında ise  
x: If Motor is lower than foot mounting plane  
x: Wenn motor ist niedriger den die Anschlußplatte

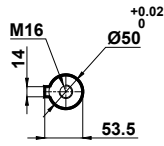

Klemens Pozisyonları  
Terminal Box Positions  
Klemmenkasten Positionen

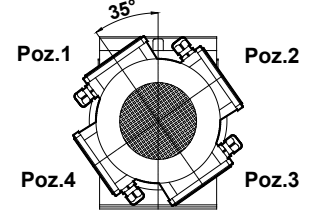

80-90-100-112-132-160-180  
Tip / Type / Typ

	80	90S	90L	100L	112M	132S	132M	160M	160L	180M	180L
k	572	600	625	663	689	738	776	851	895	912	950
k1	692	725	750	798	824	883	921	1021	1065	1082	1120
n	156	176	176	194	218	258	258	310	310	348	348
n1	118	126	126	135	146	168	168	225	225	241	241
x	-	-	-	-	-	-	-	-	-	7	7

## KR473.05

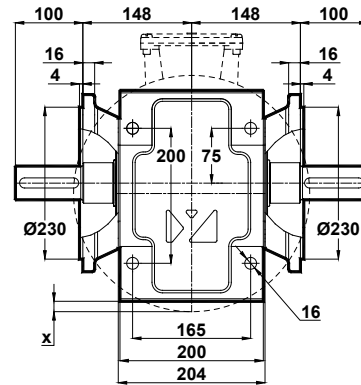
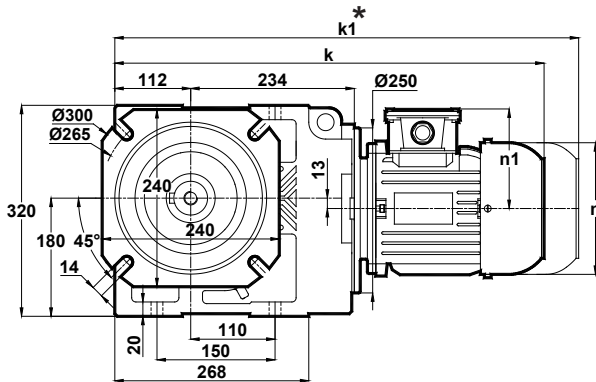

x: Motor Ayak bağlantı yüzeyinin altında ise  
x: If Motor is lower than foot mounting plane  
x: Wenn motor ist niedriger den die Anschlußplatte

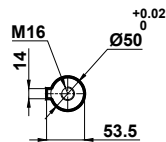

	80	90S	90L	100L	112M	132S	132M	160M	160L	180M	180L
k	572	600	625	663	689	738	776	851	895	912	950
k1	692	725	750	798	824	883	921	1021	1065	1082	1120
n	156	176	176	194	218	258	258	310	310	348	348
n1	118	126	126	135	146	168	168	225	225	241	241
x	-	-	-	-	-	-	-	-	-	7	7

\* "k1" Ölçüsü frenli redüktörlere aittir.  
Dimension "k1" is for motors with brake.  
Maße "k1" ist für Bremsenmotoren.

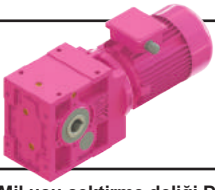

# Ölçü Sayfaları Dimension Pages Abmessungsseiten

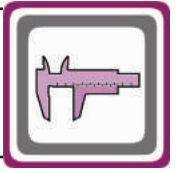

-Mil ucu çektirme deliği DIN 332 sayfa 2 / Tapped center hole to DIN 332, sheet 2 / Zentrierung mit gewinde DIN 332, Blatt 2

KR473.08

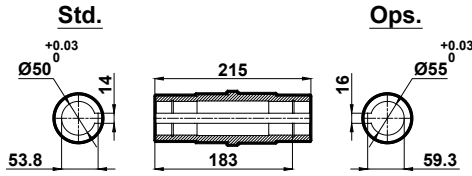
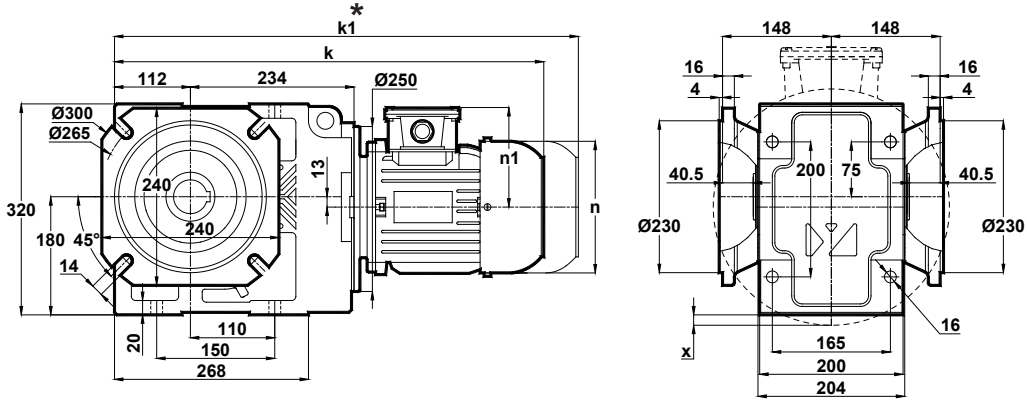

x: Motor Ayak bağlantı yüzeyinin altında ise  
x: If Motor is lower than foot mounting plane  
x: Wenn motor ist niedriger den die Anschlußplatte

	80	90S	90L	100L	112M	132S	132M	160M	160L	180M	180L
k	572	600	625	663	689	738	776	851	895	912	950
k1	692	725	750	798	824	883	921	1021	1065	1082	1120
n	156	176	176	194	218	258	258	310	310	348	348
n1	118	126	126	135	146	168	168	225	225	241	241
x	-	-	-	-	-	-	-	-	-	7	7

Klemens Pozisyonları  
Terminal Box Positions  
Klemmenkasten Positionen

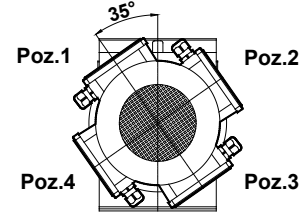

80-90-100-112-132-160-180  
Tip / Type / Typ

\* " k1 " Ölçüsü frenli redüktörlere aittir.  
Dimension " k1 " is for motors with brake.  
Maße " k1 " ist für Bremsenmotoren.

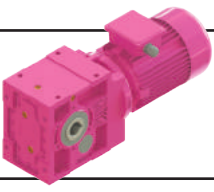

# Ölçü Sayfaları Dimension Pages Abmessungsseiten

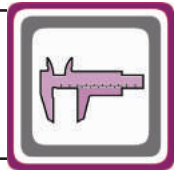

-Mil ucu çekirme deliği DIN 332 sayfa 2 / Tapped center hole to DIN 332, sheet 2 / Zentrierung mit gewinde DIN 332, Blatt 2

## KR474.00

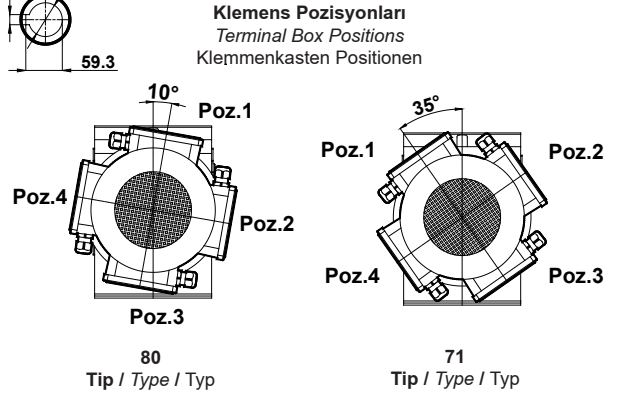
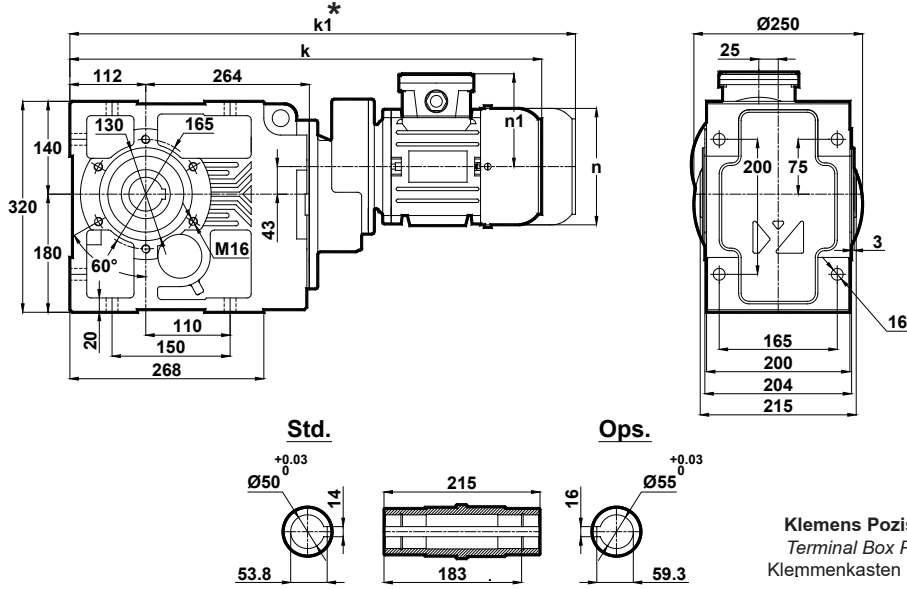

## KR474.01

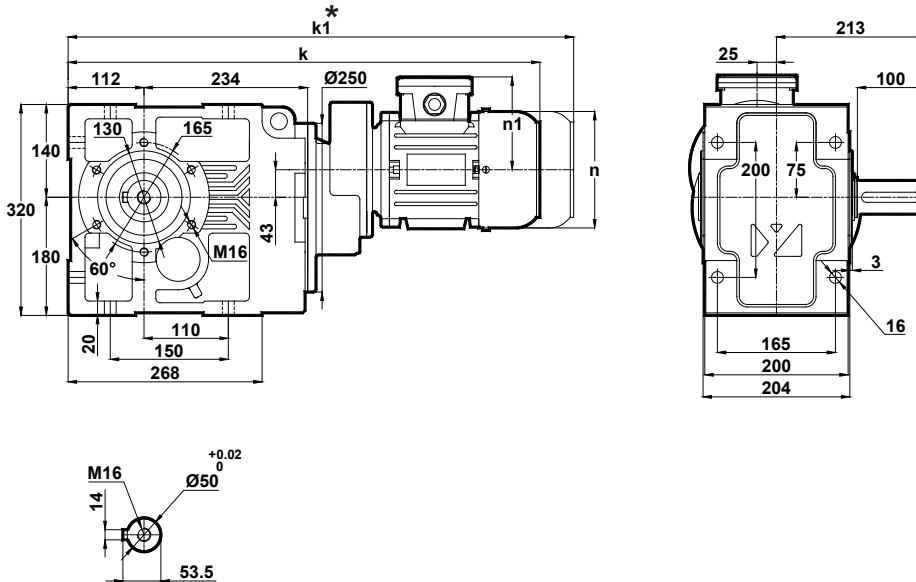

	71	80
k	637	665
k1	757	785
n	138	156
n1	110	118

\* "k1" Ölçüsü frenli redüktörlere aittir.  
Dimension "k1" is for motors with brake.  
Maße "k1" ist für Bremsenmotoren.

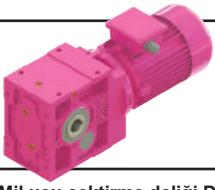

# Ölçü Sayfaları Dimension Pages Abmessungsseiten

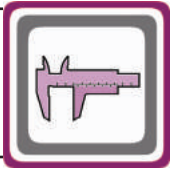

-Mil ucu çekirme deliği DIN 332 sayfa 2 / Tapped center hole to DIN 332, sheet 2 / Zentrierung mit gewinde DIN 332, Blatt 2

## KR474.02

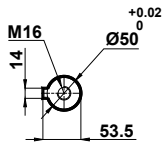
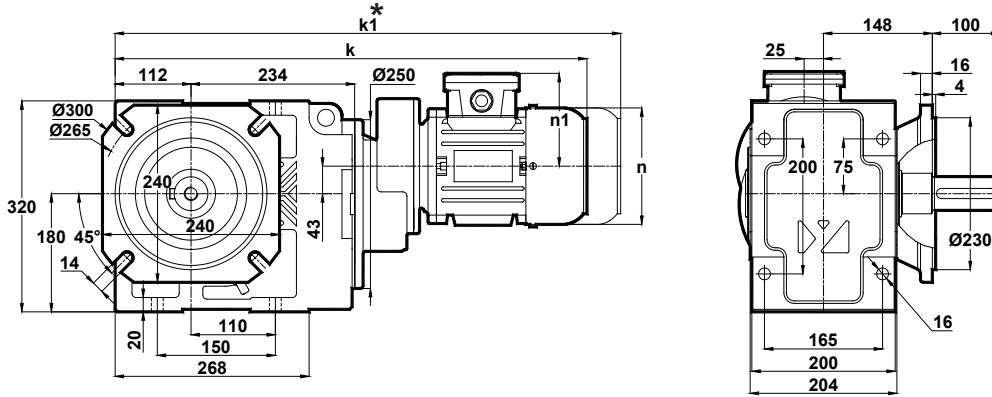

	71	80
k	637	665
k1	757	785
n	138	156
n1	110	118

Klemens Pozisyonları  
Terminal Box Positions  
Klemmenkasten Positionen

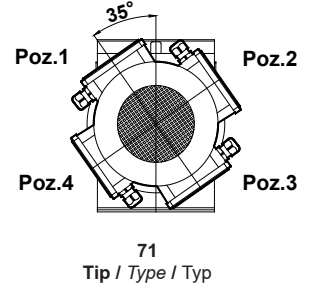
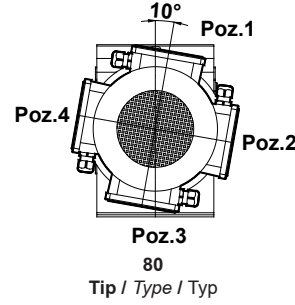

## KR474.03

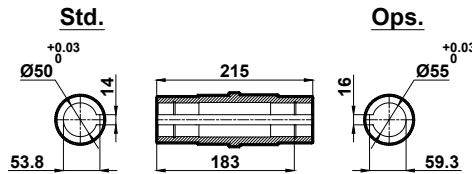
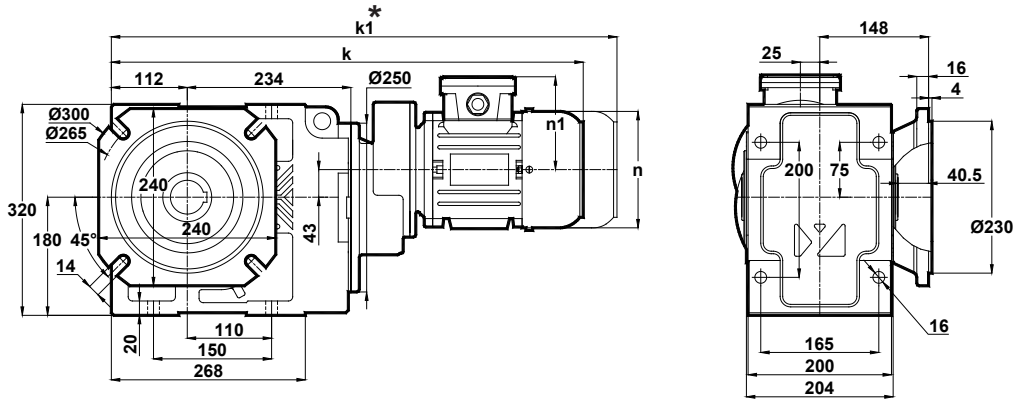

	71	80
k	637	665
k1	757	785
n	138	156
n1	110	118

\* " k1 " Ölçüsü frenli redüktörlere aittir.  
Dimension " k1 " is for motors with brake.  
Maße " k1 " ist für Bremsenmotoren.

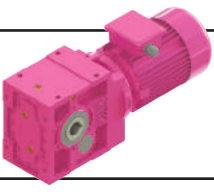

# Ölçü Sayfaları Dimension Pages Abmessungsseiten

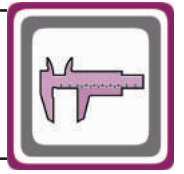

-Mil ucu çekirme deliği DIN 332 sayfa 2 / Tapped center hole to DIN 332, sheet 2 / Zentrierung mit gewinde DIN 332, Blatt 2

## KR474.04

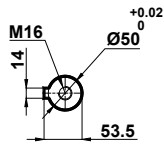
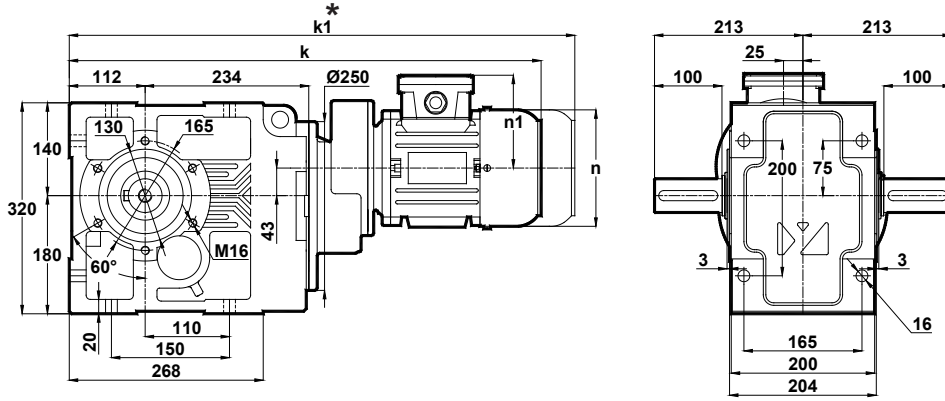

	71	80
k	637	665
k1	757	785
n	138	156
n1	110	118

Klemens Pozisyonları  
Terminal Box Positions  
Klemmenkasten Positionen

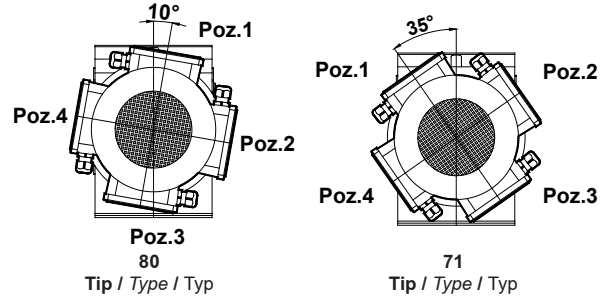

## KR474.05

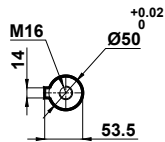
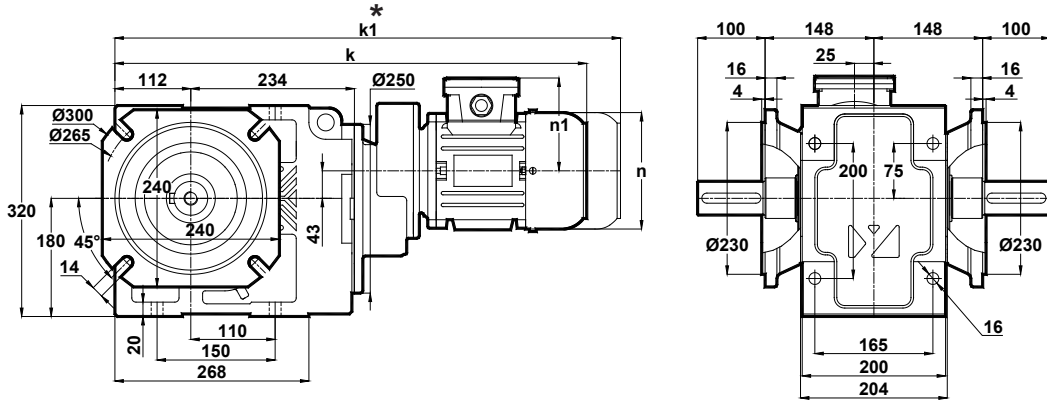

	71	80
k	637	665
k1	757	785
n	138	156
n1	110	118

\* "k1" Ölçüsü frenli redüktörlere aittir.  
Dimension "k1" is for motors with brake.  
Maße "k1" ist für Bremsmotoren.

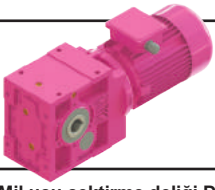

# Ölçü Sayfaları Dimension Pages Abmessungsseiten

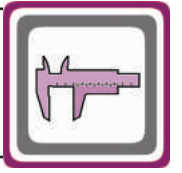

-Mil ucu çektirme deliği DIN 332 sayfa 2 / Tapped center hole to DIN 332, sheet 2 / Zentrierung mit gewinde DIN 332, Blatt 2

KR474.08

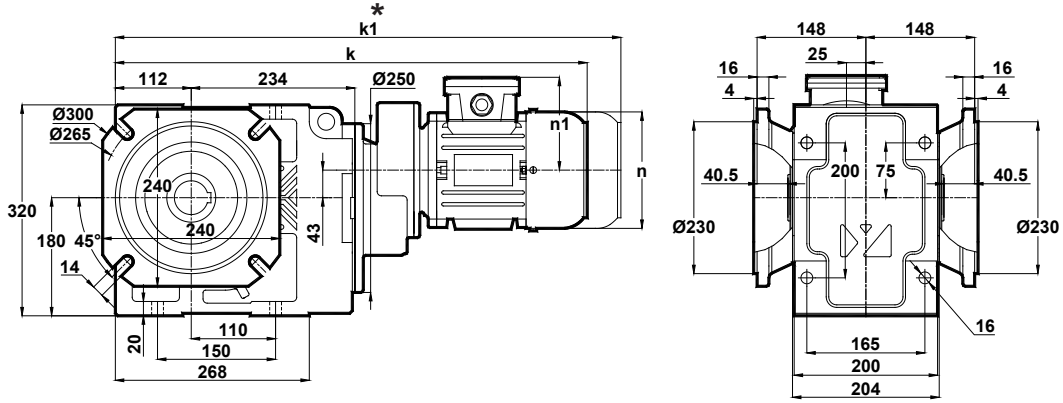

Std.

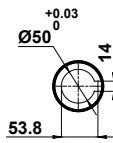

Ops.

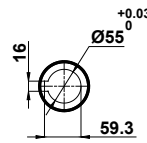

Klemens Pozisyonları  
Terminal Box Positions  
Klemmenkasten Positionen

	71	80
k	637	665
k1	757	785
n	138	156
n1	110	118

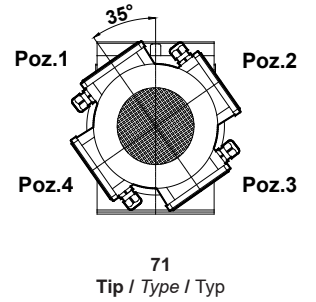
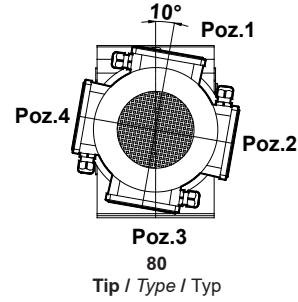

\* " k1 " Ölçüsü frenli redüktörlere aittir.  
Dimension " k1 " is for motors with brake.  
Maße " k1 " ist für Bremsenmotoren.

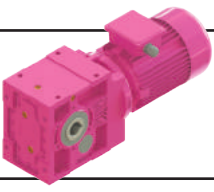

# Ölçü Sayfaları Dimension Pages Abmessungsseiten

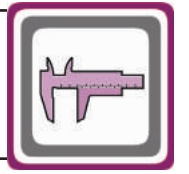

-Mil ucu çekirme deliği DIN 332 sayfa 2 / Tapped center hole to DIN 332, sheet 2 / Zentrierung mit gewinde DIN 332, Blatt 2

KR475.00  
KR476.00

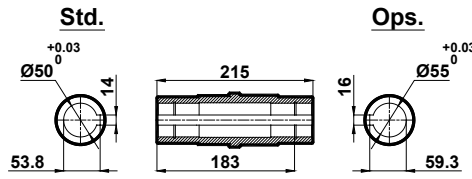
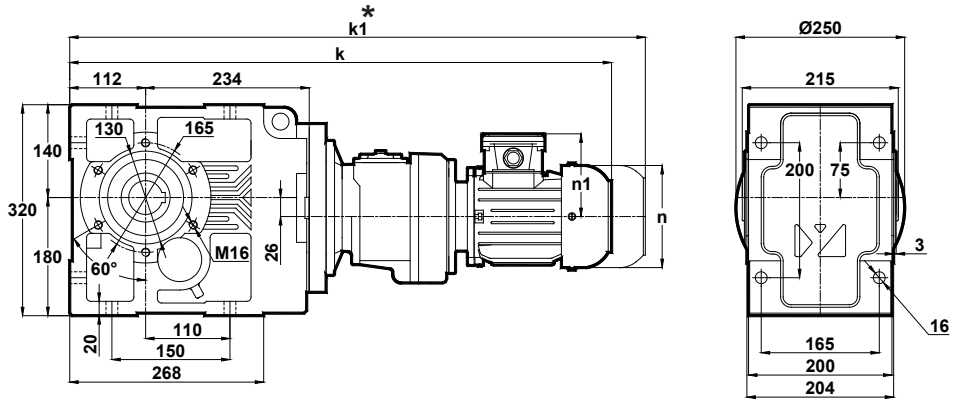

Klemens Pozisyonları  
Terminal Box Positions  
Klemmenkasten Positionen

	63	71
k	748	767
k1	-	887
n	116	138
n1	97	110

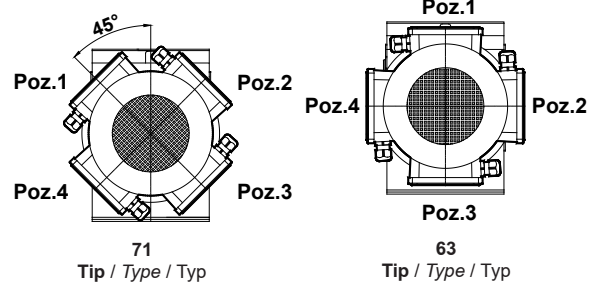

KR475.01  
KR476.01

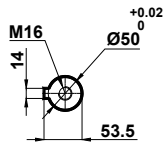
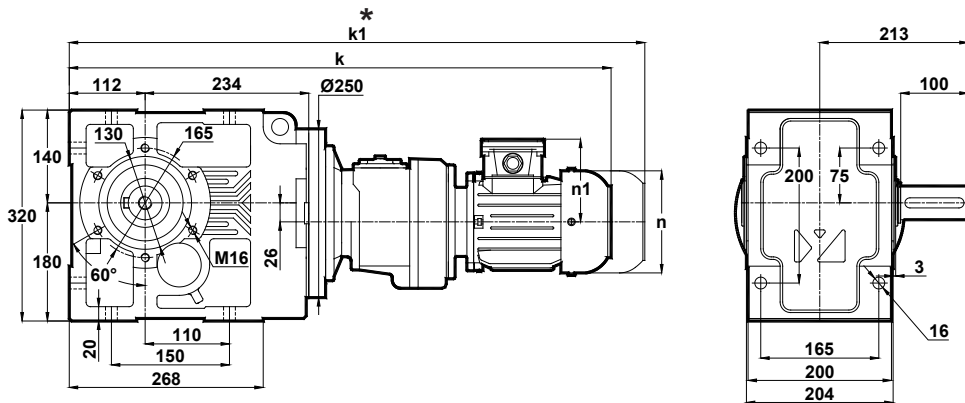

	63	71
k	748	767
k1	-	887
n	116	138
n1	97	110

\* "k1" Ölçüsü frenli redüktörlere aittir.  
Dimension "k1" is for motors with brake.  
Maße "k1" ist für Bremsenmotoren.

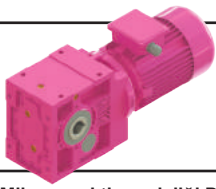

# Ölçü Sayfaları Dimension Pages Abmessungenseiten

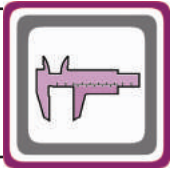

-Mil ucu çektirme deliği DIN 332 sayfa 2 / Tapped center hole to DIN 332, sheet 2 / Zentrierung mit gewinde DIN 332, Blatt 2

KR475.02  
KR476.02

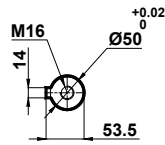
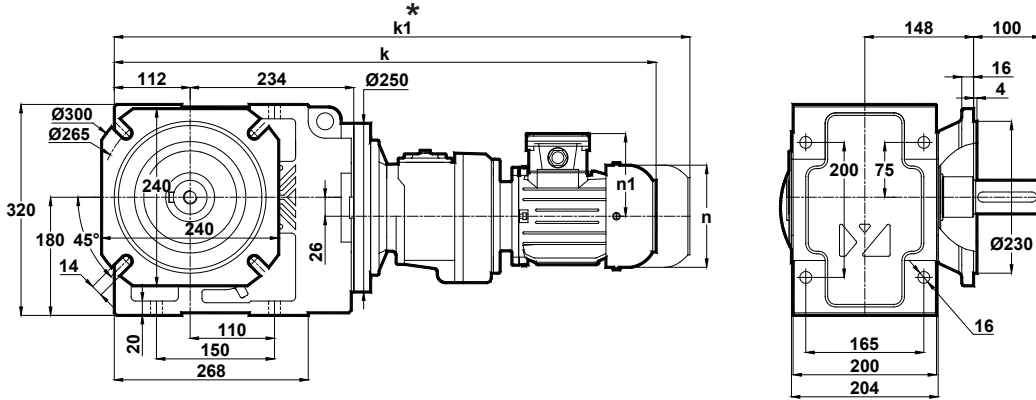

	63	71
k	748	767
k1	-	887
n	116	138
n1	97	110

Klemens Pozisyonları  
Terminal Box Positions  
Klemmenkasten Positionen

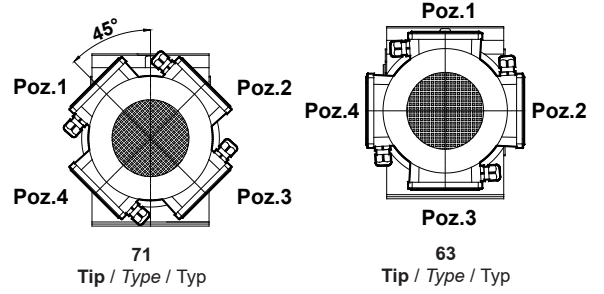

KR475.03  
KR476.03

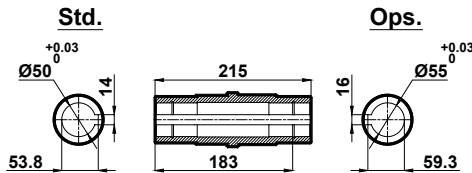
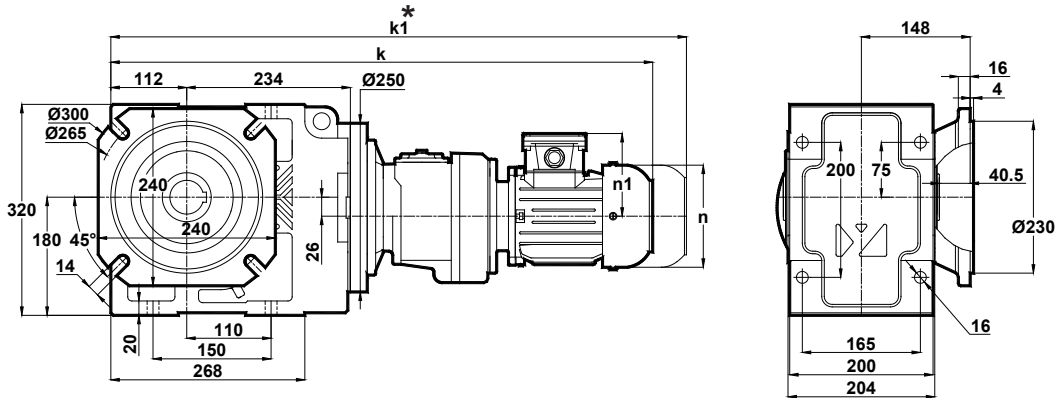

	63	71
k	748	767
k1	-	887
n	116	138
n1	97	110

\* "k1" Ölçüsü frenli redüktörlere aittir.  
Dimension "k1" is for motors with brake.  
Maße "k1" ist für Bremsenmotoren.

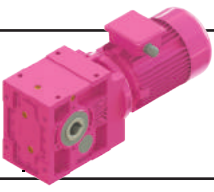

# Ölçü Sayfaları Dimension Pages Abmessungsseiten

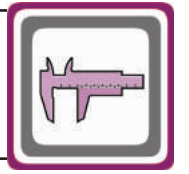

-Mil ucu çektirme deliği DIN 332 sayfa 2 / Tapped center hole to DIN 332, sheet 2 / Zentrierung mit gewinde DIN 332, Blatt 2

KR475.04  
KR476.04

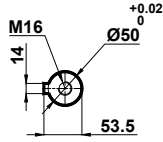
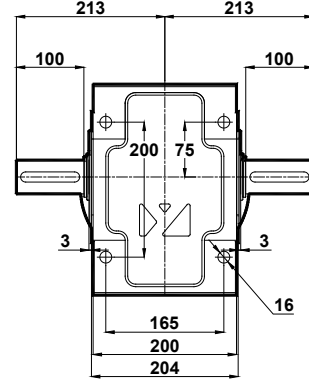
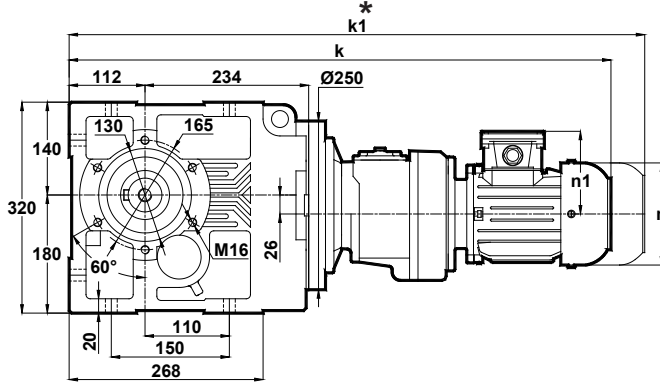

	63	71
k	748	767
k1	-	887
n	116	138
n1	97	110

Klemens Pozisyonları  
Terminal Box Positions  
Klemmenkasten Positionen

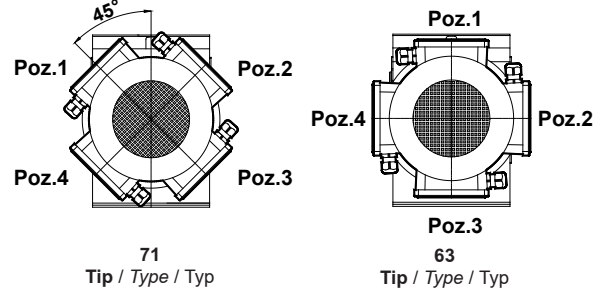

KR475.05  
KR476.05

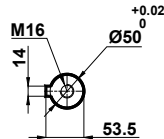
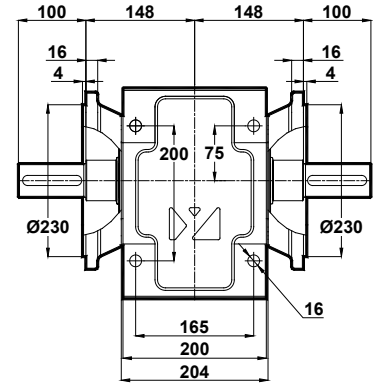
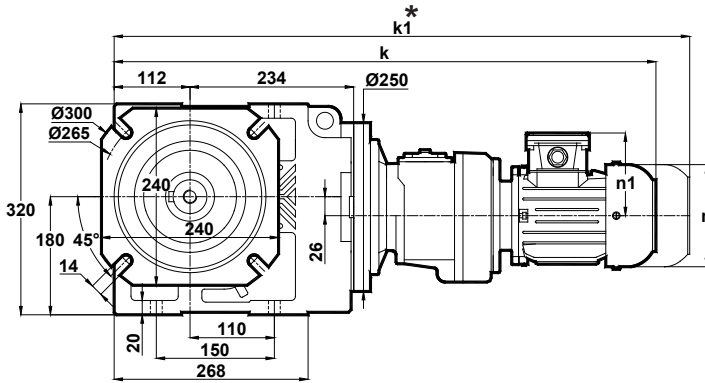

	63	71
k	748	767
k1	-	887
n	116	138
n1	97	110

\* " k1 " Ölçüsü frenli redüktörlere aittir.  
Dimension " k1 " is for motors with brake.  
Maße " k1 " ist für Bremsenmotoren.

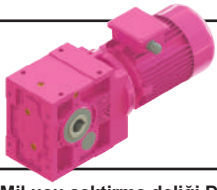

# Ölçü Sayfaları

## Dimension Pages

### Abmessungsseiten

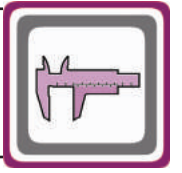

-Mil ucu çektirme deliği DIN 332 sayfa 2 / Tapped center hole to DIN 332, sheet 2 / Zentrierung mit gewinde DIN 332, Blatt 2

KR475.08  
KR476.08

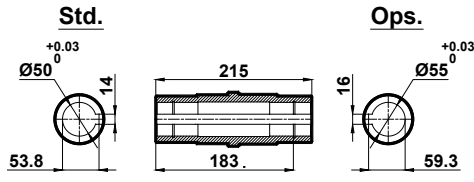
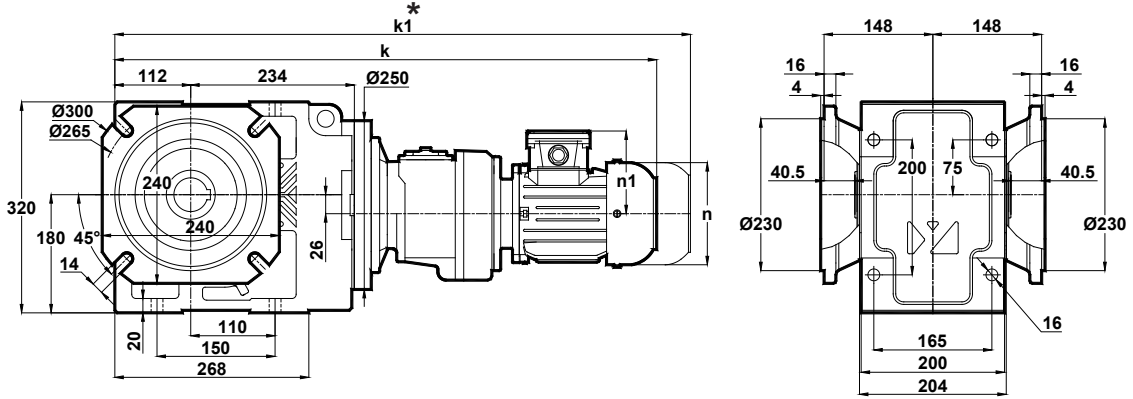

Klemens Pozisyonları  
Terminal Box Positions  
Klemmenkasten Positionen

	63	71
k	748	767
k1	-	887
n	116	138
n1	97	110

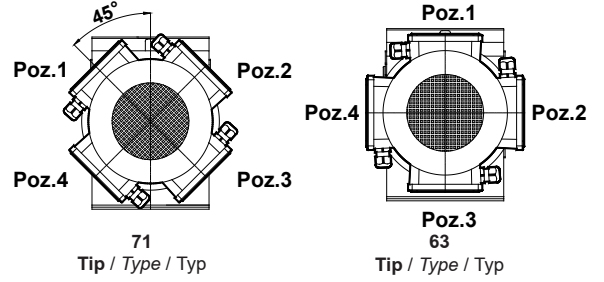

\* " k1 " Ölçüsü frenli redüktörlere aittir.  
Dimension " k1 " is for motors with brake.  
Maße " k1 " ist für Bremsenmotoren.

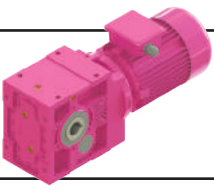

# Ölçü Sayfaları

## Dimension Pages

### Abmessungsseiten

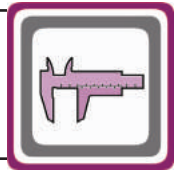

-Mil ucu çekirme deliği DIN 332 sayfa 2 / Tapped center hole to DIN 332, sheet 2 / Zentrierung mit gewinde DIN 332, Blatt 2

#### KR573.00

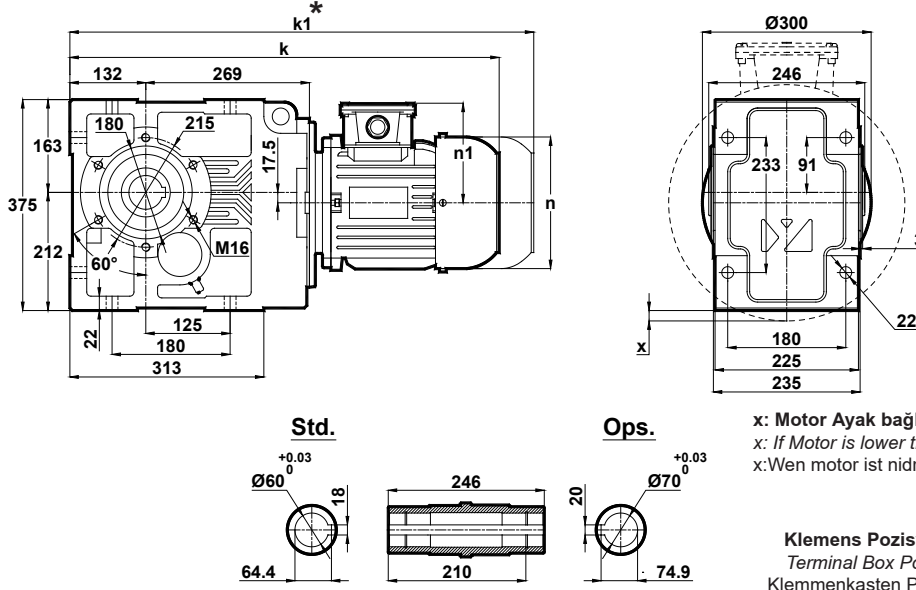

x: Motor Ayak bağlantı yüzeyinin altında ise  
x: If Motor is lower then foot mounting plane  
x: Wenn motor ist niedriger den die Anschlußplatte

Klemens Pozisyonları  
Terminal Box Positions  
Klemmenkasten Positionen

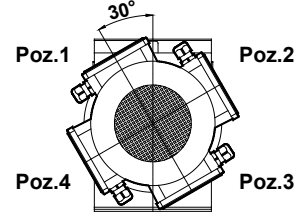

100-112-132-160-180  
Tip / Type / Typ

	100L	112M	132S	132M	160M	160L	180M	180L
k	711.5	734.5	788.5	826.5	901.5	945.5	962	1000
k1	846.5	869.5	933.5	971.5	1071.5	1115.5	1132	1170
n	194	218	258	258	310	310	348	348
n1	135	146	168	168	225	225	241	241
x	-	-	-	-	-	-	-	-

#### KR573.01

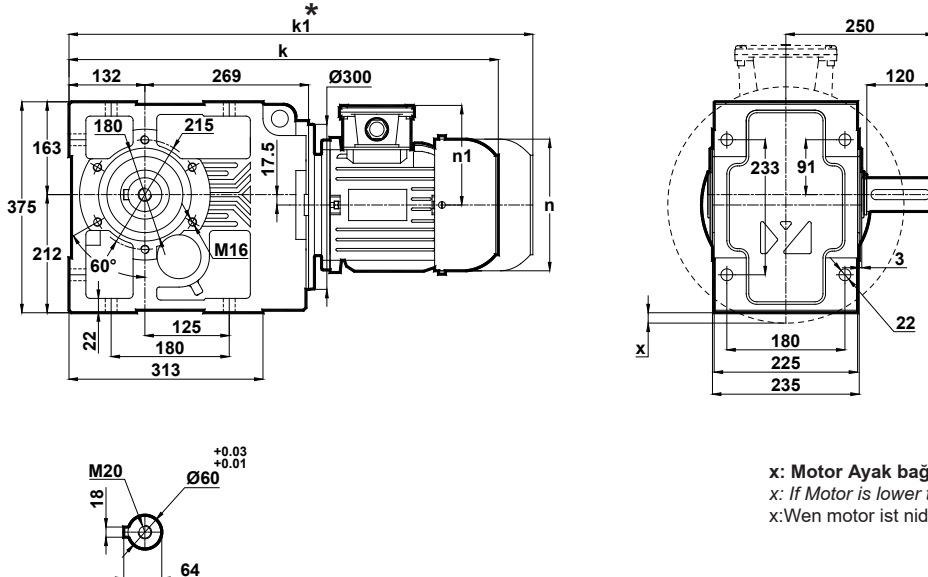

x: Motor Ayak bağlantı yüzeyinin altında ise  
x: If Motor is lower then foot mounting plane  
x: Wenn motor ist niedriger den die Anschlußplatte

	100L	112M	132S	132M	160M	160L	180M	180L
k	711.5	734.5	788.5	826.5	901.5	945.5	962	1000
k1	846.5	869.5	933.5	971.5	1071.5	1115.5	1132	1170
n	194	218	258	258	310	310	348	348
n1	135	146	168	168	225	225	241	241
x	-	-	-	-	-	-	-	-

\* "k1" Ölçüsü frenli redüktörlere aittir.  
Dimension "k1" is for motors with brake.  
Maße "k1" ist für Bremsenmotoren.

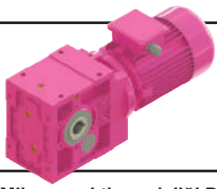

# Ölçü Sayfaları Dimension Pages Abmessungsseiten

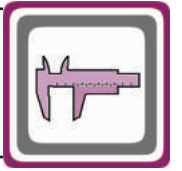

-Mil ucu çektirme deliği DIN 332 sayfa 2 / Tapped center hole to DIN 332, sheet 2 / Zentrierung mit gewinde DIN 332, Blatt 2

## KR573.02

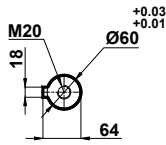
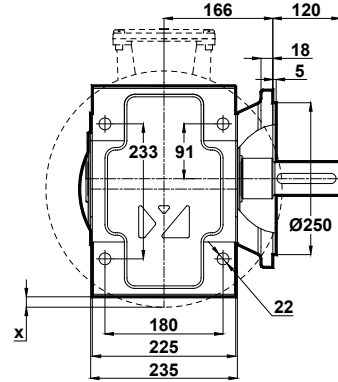
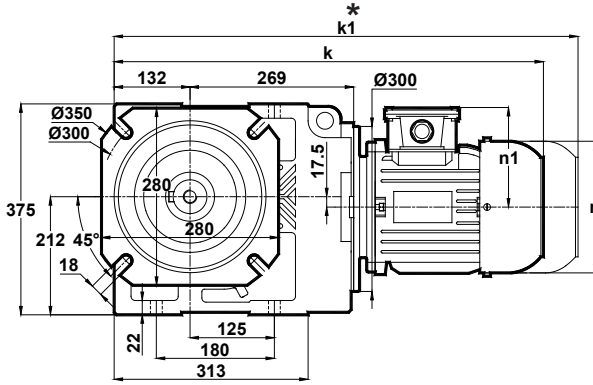

x: Motor Ayak bağlantı yüzeyinin altında ise  
x: If Motor is lower then foot mounting plane  
x: Wenn motor ist niedriger den die Anschlußplatte

Klemens Pozisyonları  
Terminal Box Positions  
Klemmenkasten Positionen

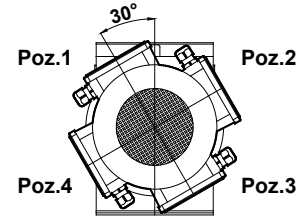

100-112-132-160-180  
Tip / Type / Type

	100L	112M	132S	132M	160M	160L	180M	180L
k	711.5	734.5	788.5	826.5	901.5	945.5	962	1000
k1	846.5	869.5	933.5	971.5	1071.5	1115.5	1132	1170
n	194	218	258	258	310	310	348	348
n1	135	146	168	168	225	225	241	241
x	-	-	-	-	-	-	-	-

## KR573.03

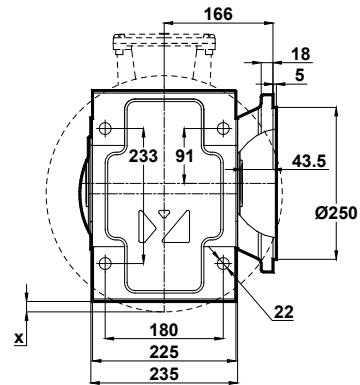
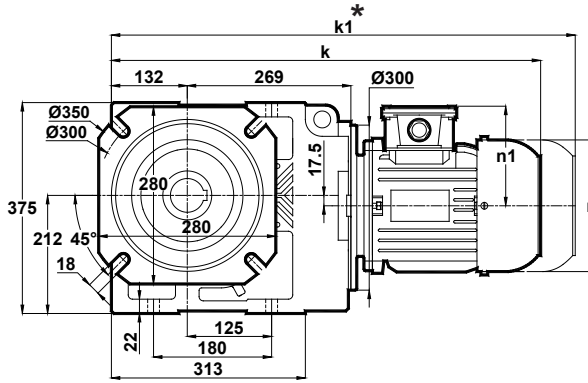

Std.

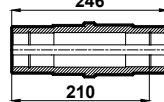
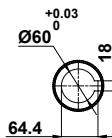

Ops.

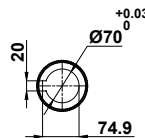

x: Motor Ayak bağlantı yüzeyinin altında ise  
x: If Motor is lower then foot mounting plane  
x: Wenn motor ist niedriger den die Anschlußplatte

	100L	112M	132S	132M	160M	160L	180M	180L
k	711.5	734.5	788.5	826.5	901.5	945.5	962	1000
k1	846.5	869.5	933.5	971.5	1071.5	1115.5	1132	1170
n	194	218	258	258	310	310	348	348
n1	135	146	168	168	225	225	241	241
x	-	-	-	-	-	-	-	-

\* " k1 " Ölçüsü frenli redüktörlere aittir.  
Dimension " k1 " is for motors with brake.  
Maße " k1 " ist für Bremsenmotoren.

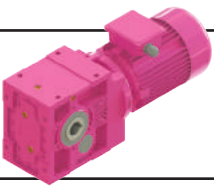

# Ölçü Sayfaları Dimension Pages Abmessungsseiten

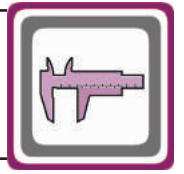

-Mil ucu çekirme deliği DIN 332 sayfa 2 / Tapped center hole to DIN 332, sheet 2 / Zentrierung mit gewinde DIN 332, Blatt 2

## KR573.04

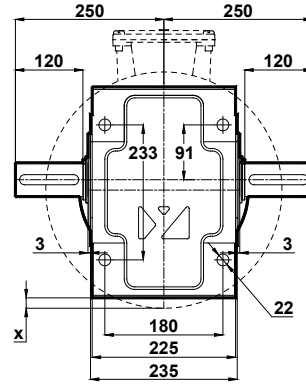
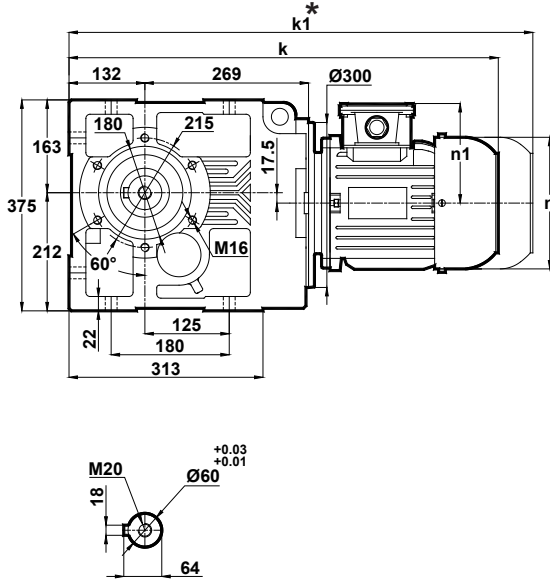

x: Motor Ayak bağlantı yüzeyinin altında ise  
x: If Motor is lower then foot mounting plane  
x: Wenn motor ist niedriger den die Anschlußplatte

	100L	112M	132S	132M	160M	160L	180M	180L
k	711.5	734.5	788.5	826.5	901.5	945.5	962	1000
k1	846.5	869.5	933.5	971.5	1071.5	1115.5	1132	1170
n	194	218	258	258	310	310	348	348
n1	135	146	168	168	225	225	241	241
x	-	-	-	-	-	-	-	-

Klemens Pozisyonları  
Terminal Box Positions  
Klemmenkasten Positionen

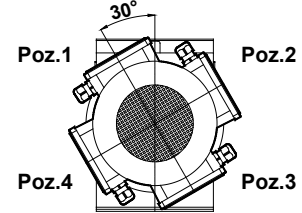

100-112-132-160-180  
Tip / Type / Typ

## KR573.05

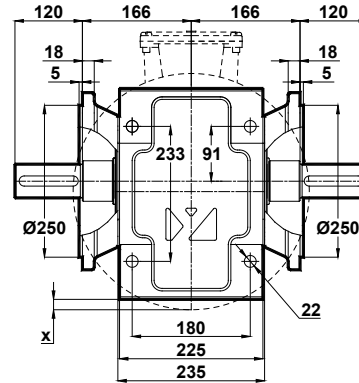
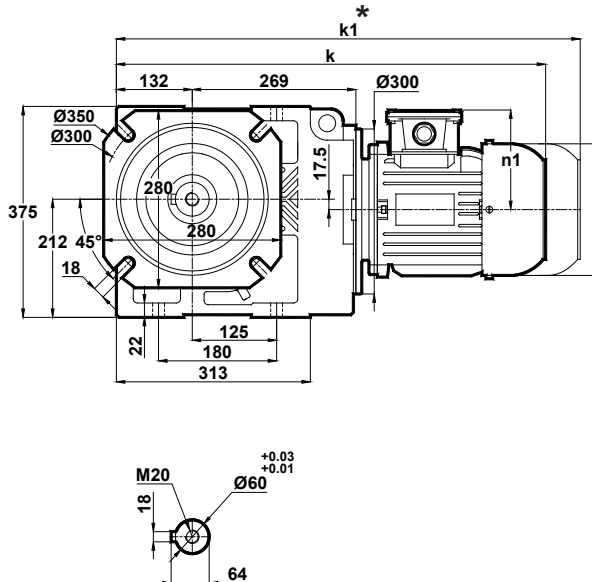

x: Motor Ayak bağlantı yüzeyinin altında ise  
x: If Motor is lower then foot mounting plane  
x: Wenn motor ist niedriger den die Anschlußplatte

	100L	112M	132S	132M	160M	160L	180M	180L
k	711.5	734.5	788.5	826.5	901.5	945.5	962	1000
k1	846.5	869.5	933.5	971.5	1071.5	1115.5	1132	1170
n	194	218	258	258	310	310	348	348
n1	135	146	168	168	225	225	241	241
x	-	-	-	-	-	-	-	-

\* "k1" Ölçüsü frenli redüktörlere aittir.  
Dimension "k1" is for motors with brake.  
Maße "k1" ist für Bremsenmotoren.

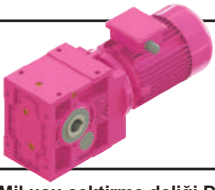

# Ölçü Sayfaları Dimension Pages Abmessungsseiten

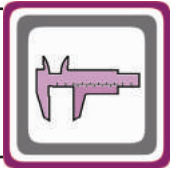

-Mil ucu çektirme deliği DIN 332 sayfa 2 / Tapped center hole to DIN 332, sheet 2 / Zentrierung mit gewinde DIN 332, Blatt 2

KR573.08

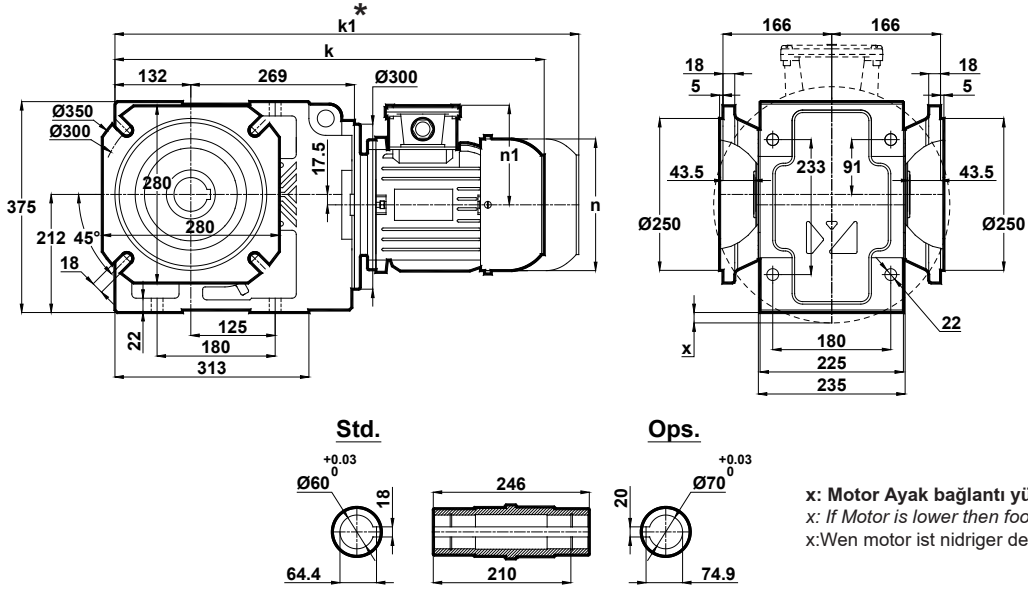

x: Motor Ayak bağlantı yüzeyinin altında ise  
x: If Motor is lower then foot mounting plane  
x: Wenn motor ist niedriger den die Anschlußplatte

	100L	112M	132S	132M	160M	160L	180M	180L
k	711.5	734.5	788.5	826.5	901.5	945.5	962	1000
k1	846.5	869.5	933.5	971.5	1071.5	1115.5	1132	1170
n	194	218	258	258	310	310	348	348
n1	135	146	168	168	225	225	241	241
x	-	-	-	-	-	-	-	-

Klemens Pozisyonları  
Terminal Box Positions  
Klemmenkasten Positionen

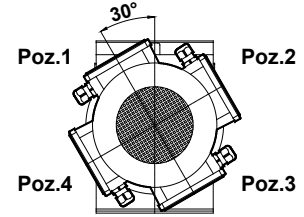

100-112-132-160-180  
Tio / Tvpe / Tvo

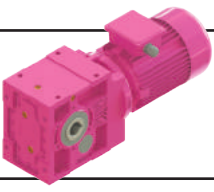

# Ölçü Sayfaları

## Dimension Pages

### Abmessungsseiten

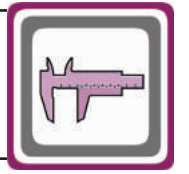

-Mil ucu çekirme deliği DIN 332 sayfa 2 / Tapped center hole to DIN 332, sheet 2 / Zentrierung mit gewinde DIN 332, Blatt 2

#### KR574.00

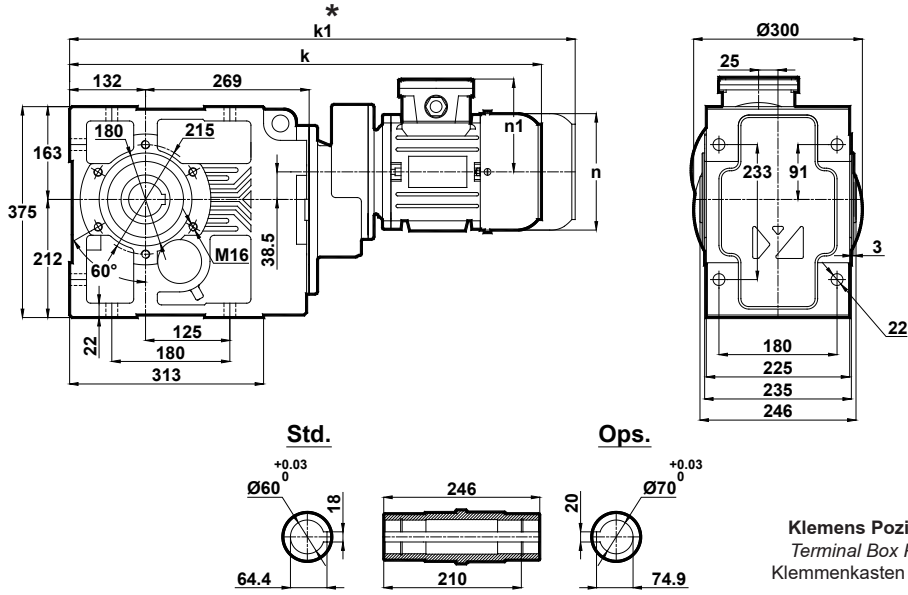

	71	80	90S	90L	100L
k	690	718	747	772	812
k1	810	838	872	897	947
n	138	156	176	176	194
n1	110	118	126	126	135

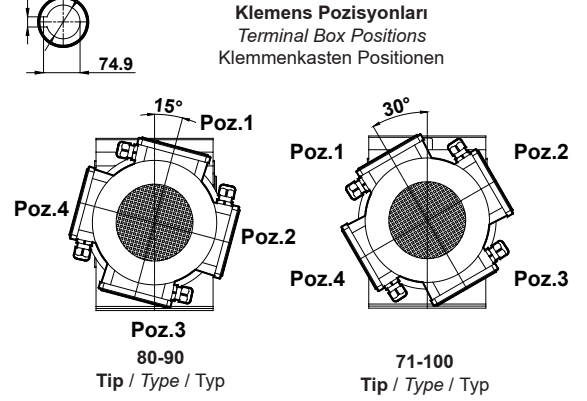

#### KR574.01

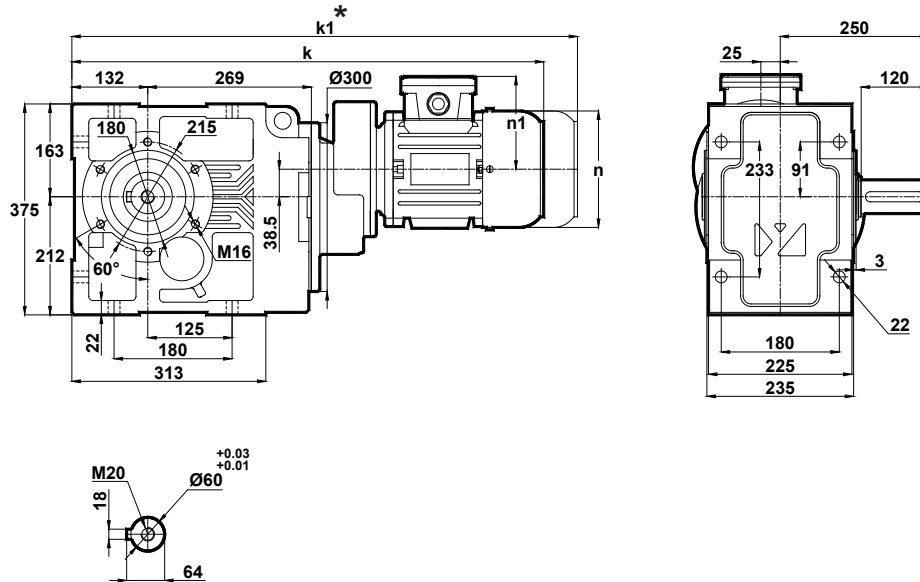

	71	80	90S	90L	100L
k	690	718	747	772	812
k1	810	838	872	897	947
n	138	156	176	176	194
n1	110	118	126	126	135

\* "k1" Ölçüsü frenli redüktörlere aittir.  
Dimension "k1" is for motors with brake.  
Maße "k1" ist für Bremsenmotoren.

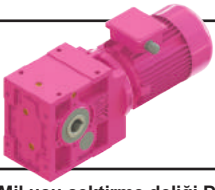

# Ölçü Sayfaları Dimension Pages Abmessungsseiten

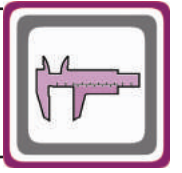

-Mil ucu çektirme deliği DIN 332 sayfa 2 / Tapped center hole to DIN 332, sheet 2 / Zentrierung mit gewinde DIN 332, Blatt 2

## KR574.02

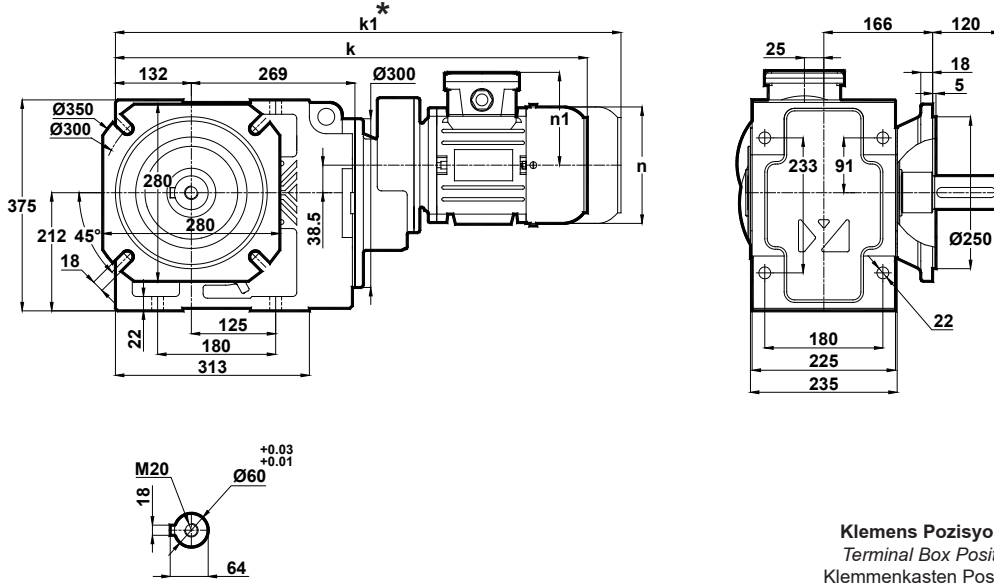

Klemens Pozisyonları  
Terminal Box Positions  
Klemmenkasten Positionen

	71	80	90S	90L	100L
k	690	718	747	772	812
k1	810	838	872	897	947
n	138	156	176	176	194
n1	110	118	126	126	135

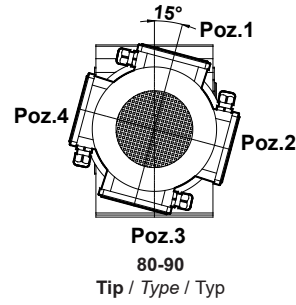

80-90  
Tip / Type / Typ

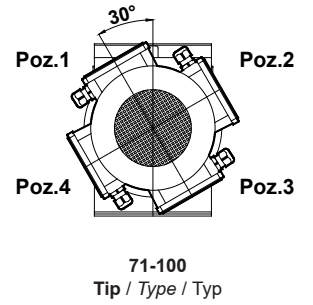

71-100  
Tip / Type / Typ

## KR574.03

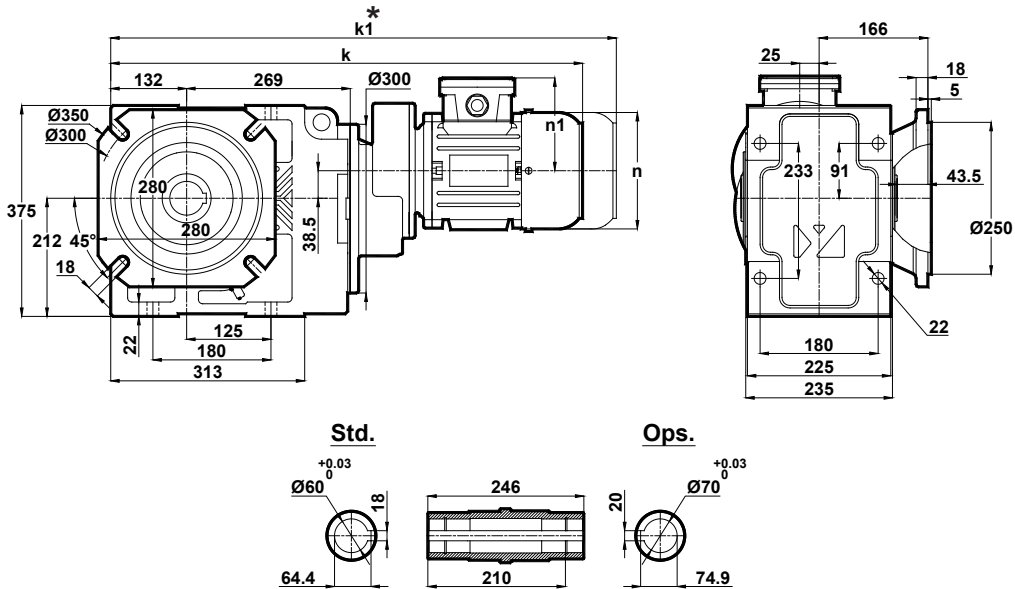

	71	80	90S	90L	100L
k	690	718	747	772	812
k1	810	838	872	897	947
n	138	156	176	176	194
n1	110	118	126	126	135

\* " k1 " Ölçüsü frenli redüktörlere aittir.  
Dimension " k1 " is for motors with brake.  
Maße " k1 " ist für Bremsenmotoren.

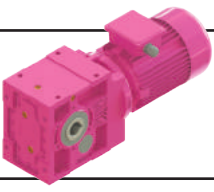

# Ölçü Sayfaları Dimension Pages Abmessungsseiten

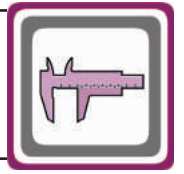

-Mil ucu çekirme deliği DIN 332 sayfa 2 / Tapped center hole to DIN 332, sheet 2 / Zentrierung mit gewinde DIN 332, Blatt 2

## KR574.04

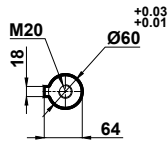
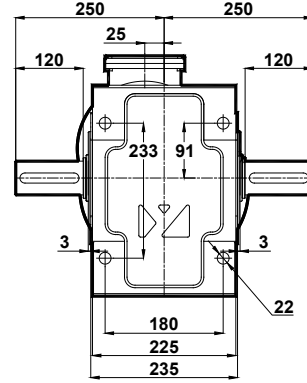
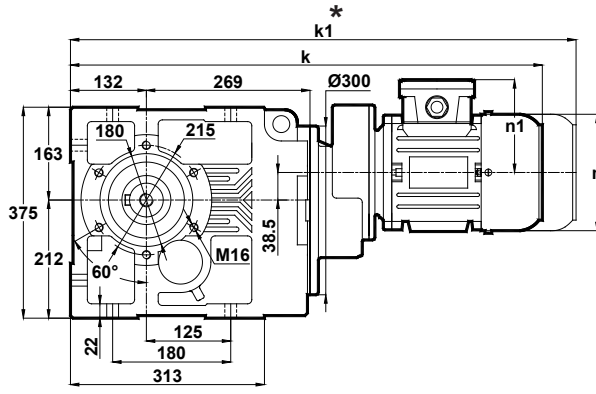

	71	80	90S	90L	100L
k	690	718	747	772	812
k1	810	838	872	897	947
n	138	156	176	176	194
n1	110	118	126	126	135

Klemens Pozisyonları  
Terminal Box Positions  
Klemmenkasten Positionen

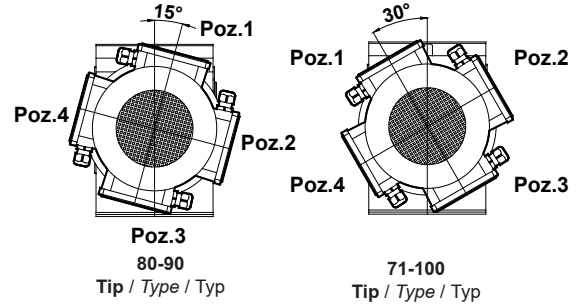

## KR574.05

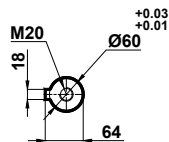
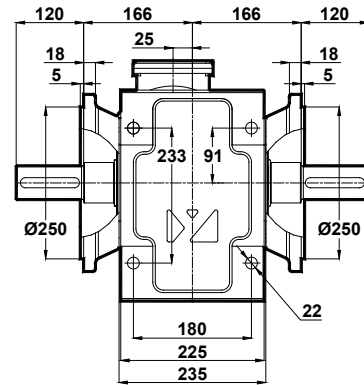
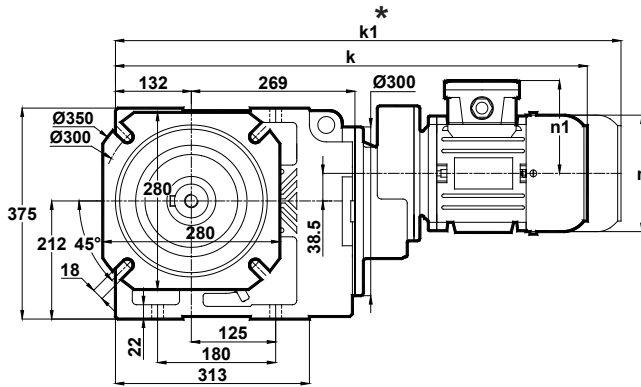

	71	80	90S	90L	100L
k	690	718	747	772	812
k1	810	838	872	897	947
n	138	156	176	176	194
n1	110	118	126	126	135

\* "k1" Ölçüsü frenli redüktörlere aittir.  
Dimension "k1" is for motors with brake.  
Maße "k1" ist für Bremsmotoren.

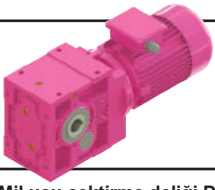

# Ölçü Sayfaları Dimension Pages Abmessungsseiten

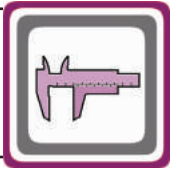

-Mil ucu çektirme deliği DIN 332 sayfa 2 / Tapped center hole to DIN 332, sheet 2 / Zentrierung mit gewinde DIN 332, Blatt 2

KR574.08

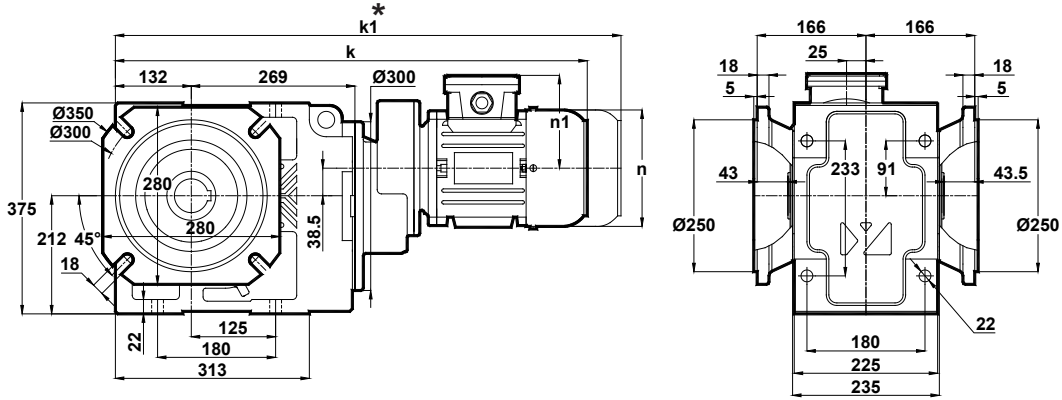

Std.

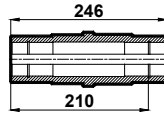
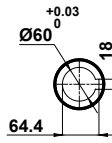

Ops.

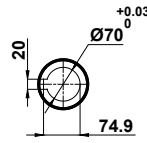

Klemens Pozisyonları  
Terminal Box Positions  
Klemmenkasten Positionen

	71	80	90S	90L	100L
k	690	718	747	772	812
k1	810	838	872	897	947
n	138	156	176	176	194
n1	110	118	126	126	135

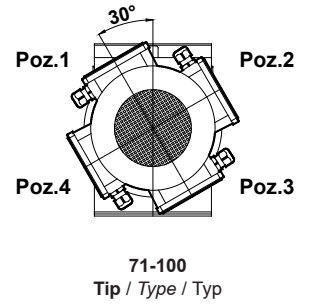
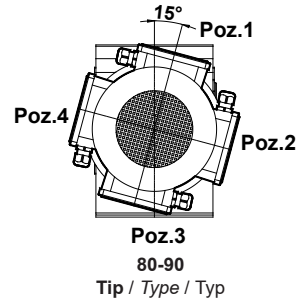

\* " k1 " Ölçüsü frenli redüktörlere aittir.  
Dimension " k1 " is for motors with brake.  
Maße " k1 " ist für Bremsenmotoren.

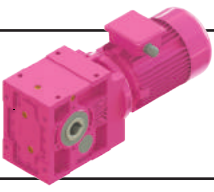

# Ölçü Sayfaları Dimension Pages Abmessungsseiten

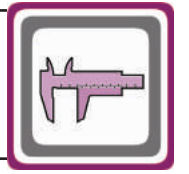

-Mil ucu çektirme deliği DIN 332 sayfa 2 / Tapped center hole to DIN 332, sheet 2 / Zentrierung mit gewinde DIN 332, Blatt 2

KR575.00  
KR576.00

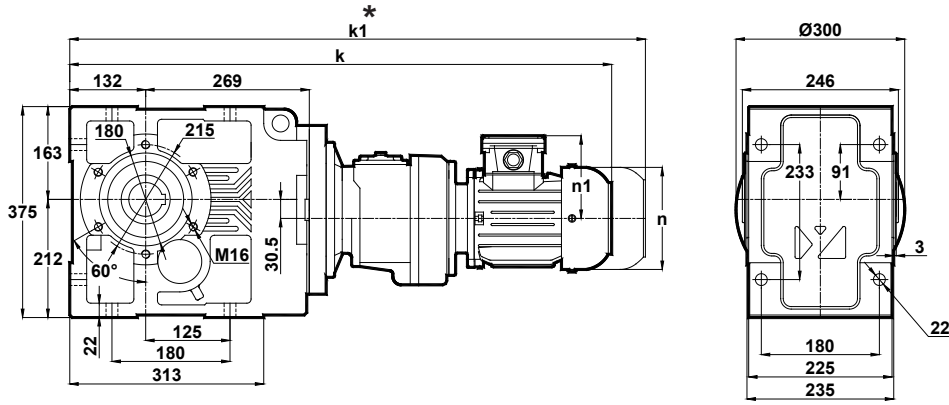

Std.

Ops.

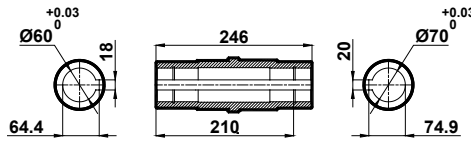

Klemens Pozisyonları  
Terminal Box Positions  
Klemmenkasten Positionen

	63	71	80
k	803	822	850
k1	-	942	970
n	116	138	156
n1	97	110	118

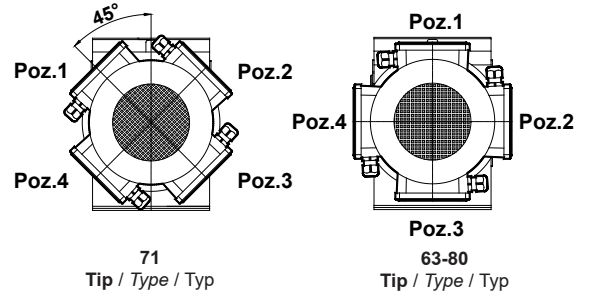

KR575.01  
KR576.01

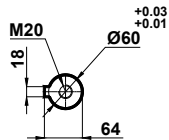
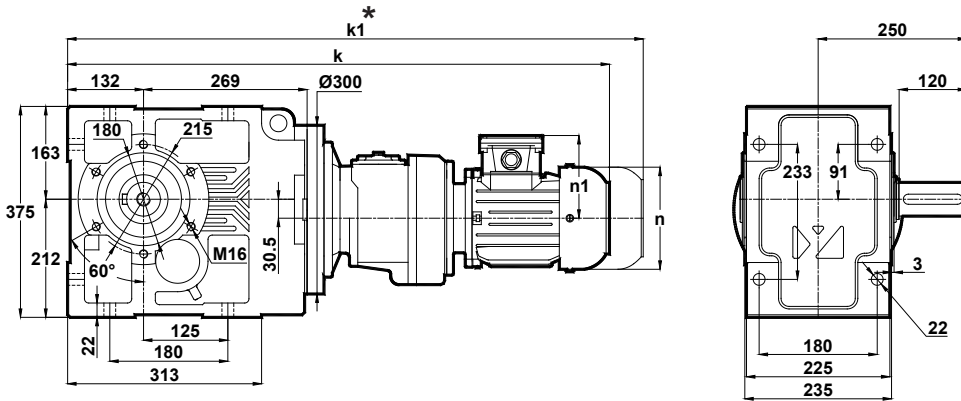

	63	71	80
k	803	822	850
k1	-	942	970
n	116	138	156
n1	97	110	118

\* "k1" Ölçüsü frenli redüktörlere aittir.  
Dimension "k1" is for motors with brake.  
Maße "k1" ist für Bremsenmotoren.

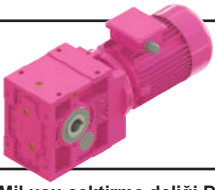

# Ölçü Sayfaları Dimension Pages Abmessungsseiten

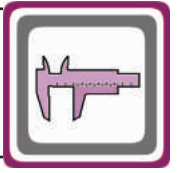

-Mil ucu çektirme deliği DIN 332 sayfa 2 / Tapped center hole to DIN 332, sheet 2 / Zentrierung mit gewinde DIN 332, Blatt 2

KR575.02  
KR576.02

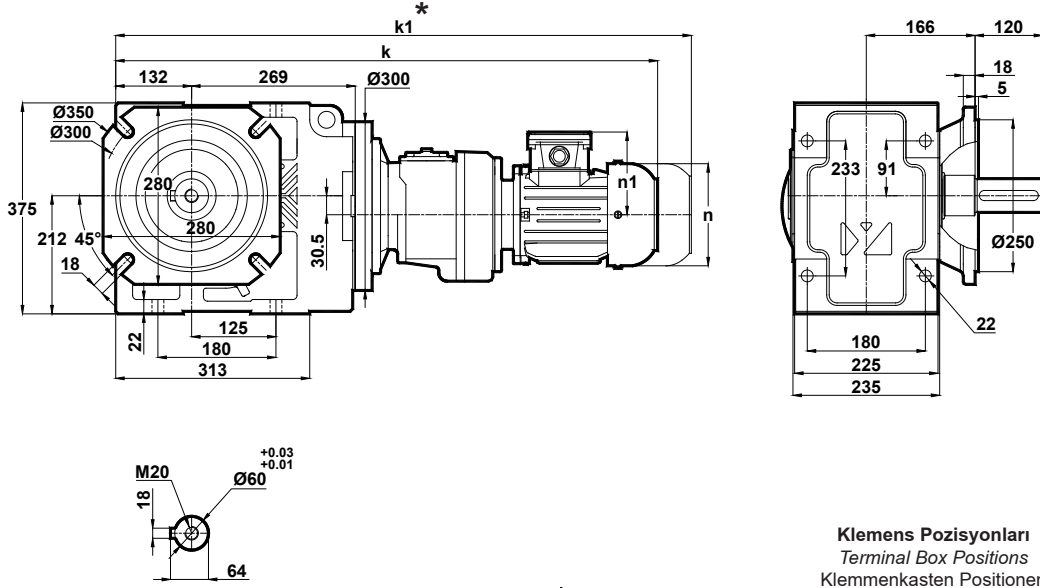

	63	71	80
k	803	822	850
k1	-	942	970
n	116	138	156
n1	97	110	118

Klemens Pozisyonları  
Terminal Box Positions  
Klemmenkasten Positionen

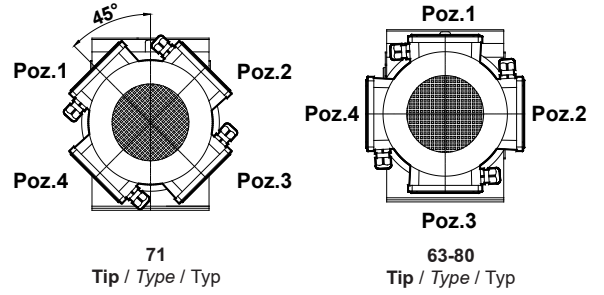

KR575.03  
KR576.03

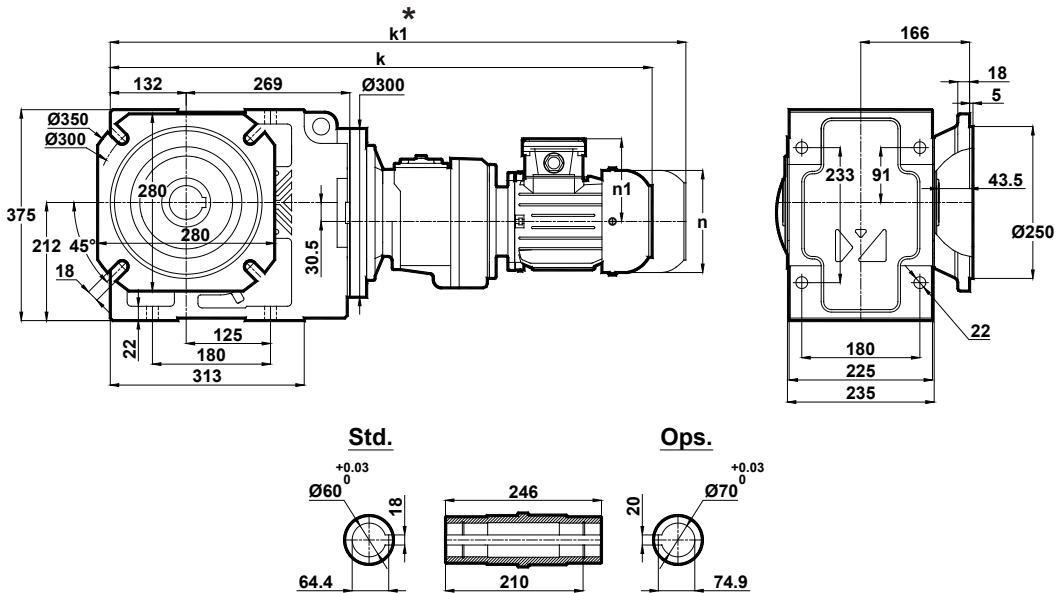

	63	71	80
k	803	822	850
k1	-	942	970
n	116	138	156
n1	97	110	118

\* " k1 " Ölçüsü frenli redüktörlere aittir.  
Dimension " k1 " is for motors with brake.  
Maße " k1 " ist für Bremsenmotoren.

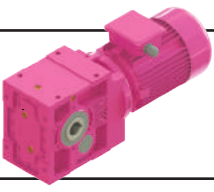

# Ölçü Sayfaları Dimension Pages Abmessungenseiten

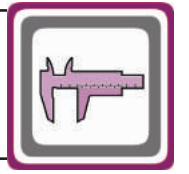

-Mil ucu çektirme deliği DIN 332 sayfa 2 / Tapped center hole to DIN 332, sheet 2 / Zentrierung mit gewinde DIN 332, Blatt 2

KR575.04  
KR576.04

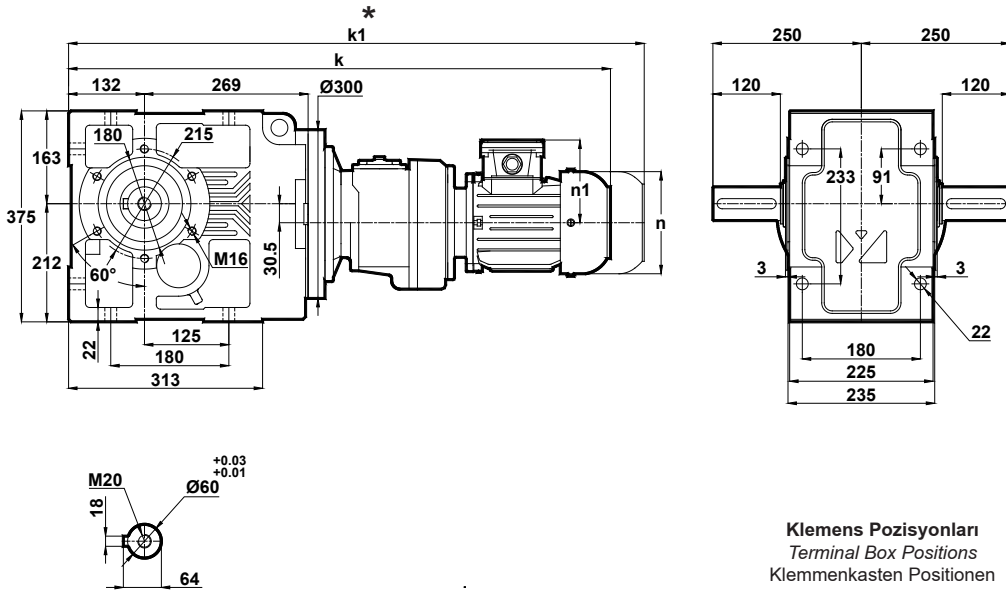

Klemens Pozisyonları  
Terminal Box Positions  
Klemmenkasten Positionen

	63	71	80
k	803	822	850
k1	-	942	970
n	116	138	156
n1	97	110	118

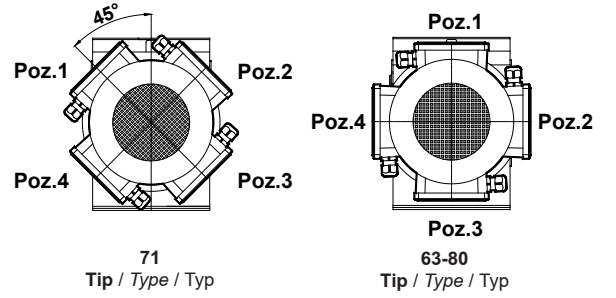

KR575.05  
KR576.05

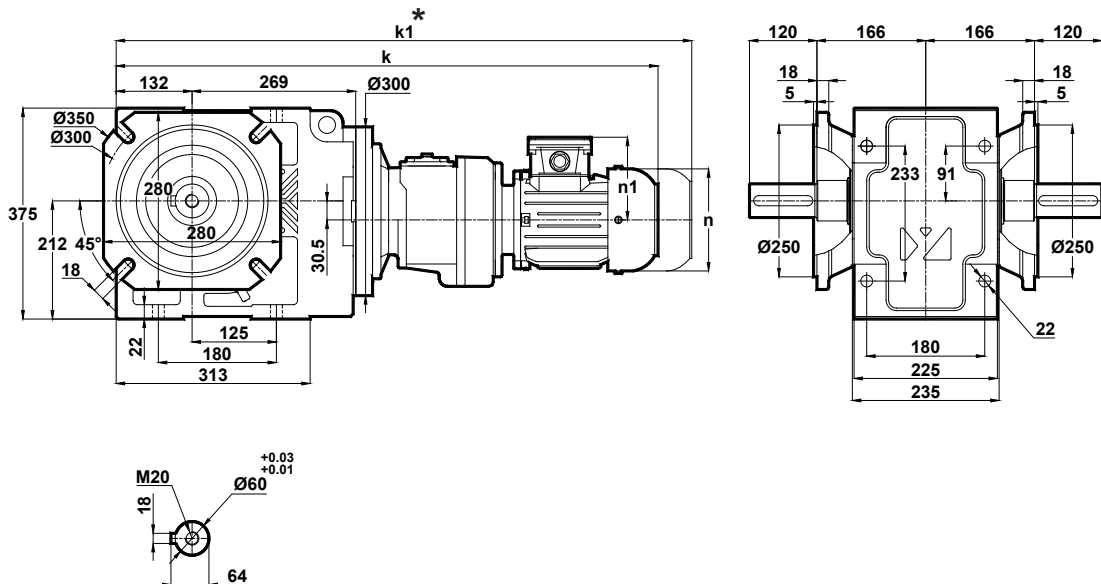

	63	71	80
k	803	821.5	850
k1	-	941.5	970
n	116	138	156
n1	97	110	118

\* "k1" Ölçüsü frenli redüktörlere aittir.  
Dimension "k1" is for motors with brake.  
Maße "k1" ist für Bremsenmotoren.

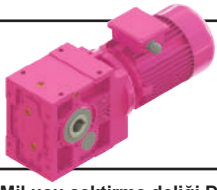

# Ölçü Sayfaları Dimension Pages Abmessungsseiten

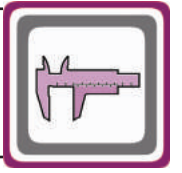

-Mil ucu çektirme deliği DIN 332 sayfa 2 / Tapped center hole to DIN 332, sheet 2 / Zentrierung mit gewinde DIN 332, Blatt 2

KR575.08  
KR576.08

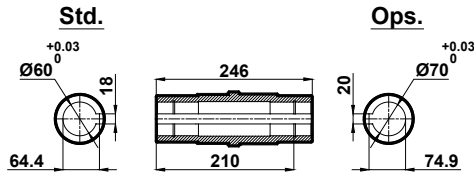
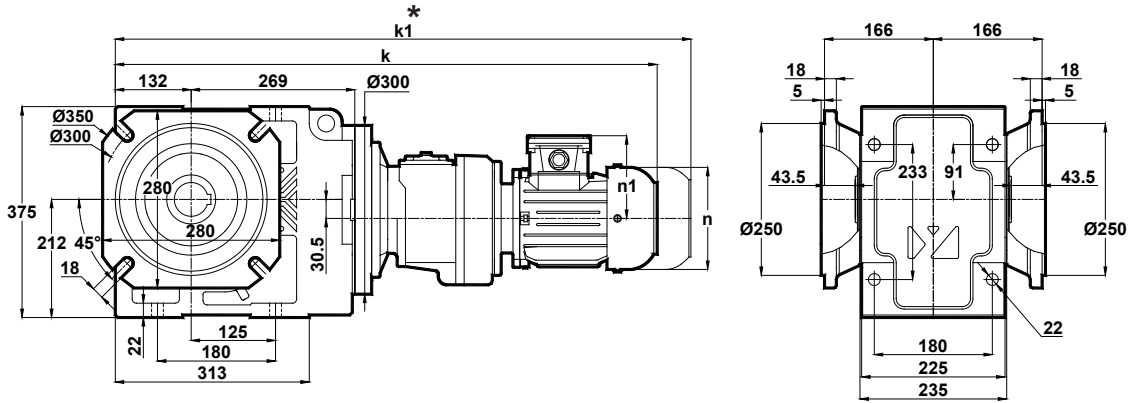

Klemens Pozisyonları  
Terminal Box Positions  
Klemmenkasten Positionen

	63	71	80
k	803	821.5	850
k1	-	941.5	970
n	116	138	156
n1	97	110	118

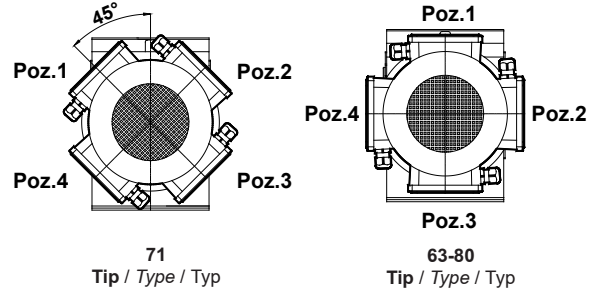

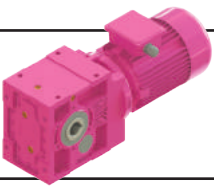

# Ölçü Sayfaları Dimension Pages Abmessungenseiten

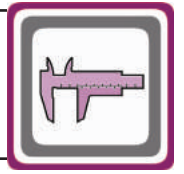

-Mil ucu çektirme deliği DIN 332 sayfa 2 / Tapped center hole to DIN 332, sheet 2 / Zentrierung mit gewinde DIN 332, Blatt 2

## KR673.00

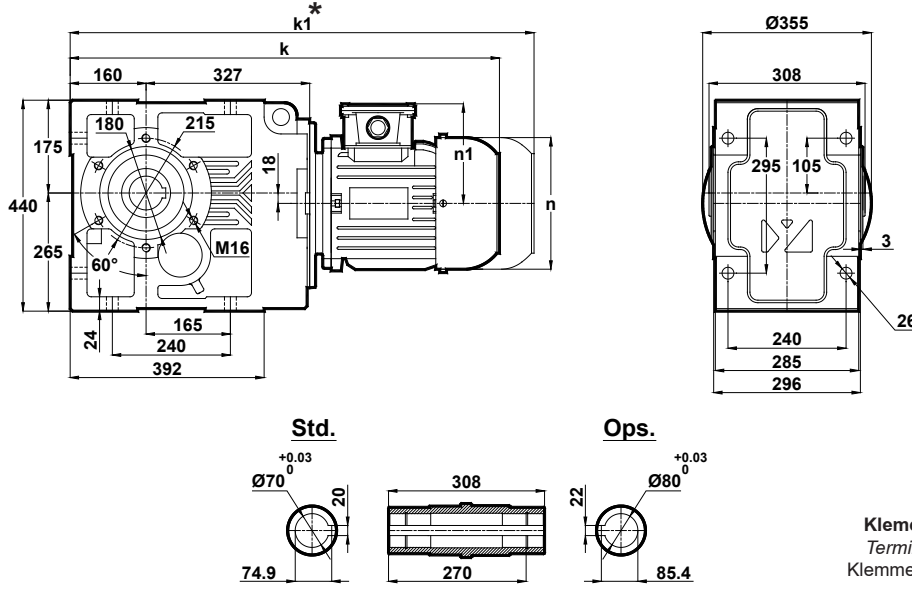

Klemens Pozisyonları  
Terminal Box Positions  
Klemmenkasten Positionen

	100L	112M	132S	132M	160M	160L	180M	180L	200L	225S	225M
k	790	813	867	905	979	1023	1037	1075	1117	1143	1168
k1	839	948	1012	1050	1149	1193	1207	1245	1317	-	-
n	194	218	258	258	310	310	348	348	390	433	433
n1	135	146	168	168	225	225	241	241	275	285	285

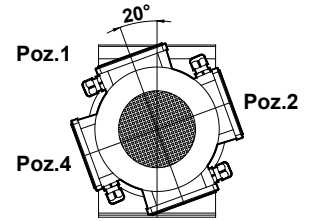

Poz.1  
Poz.2  
Poz.3  
Poz.4  
100-112-132-160-180-200-225  
Tip / Type / Typ

## KR673.01

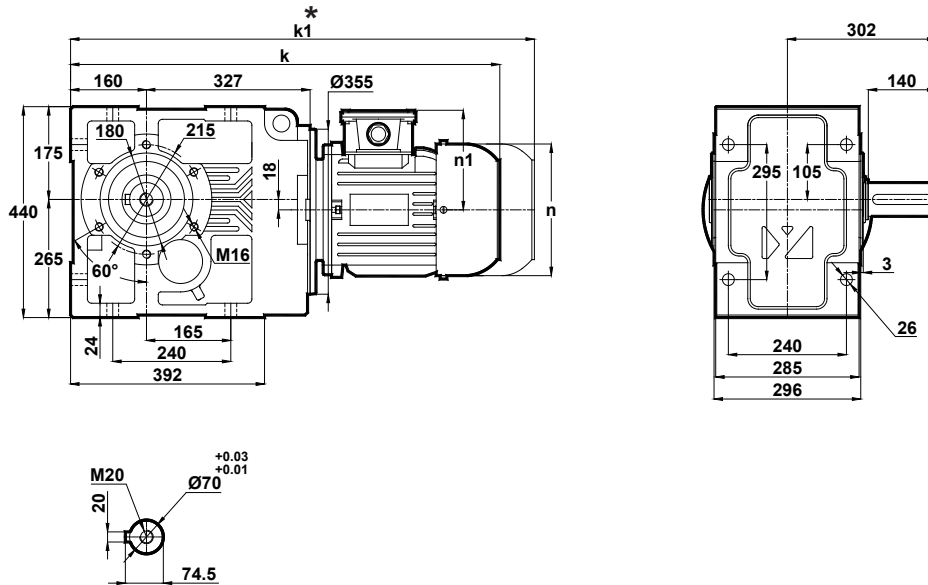

	100L	112M	132S	132M	160M	160L	180M	180L	200L	225S	225M
k	790	813	867	905	979	1023	1037	1075	1117	1143	1168
k1	839	948	1012	1050	1149	1193	1207	1245	1317	-	-
n	194	218	258	258	310	310	348	348	390	433	433
n1	135	146	168	168	225	225	241	241	275	285	285

\* "k1" Ölçüsü frenli redüktörlere aittir.  
Dimension "k1" is for motors with brake.  
Maße "k1" ist für Bremsenmotoren.

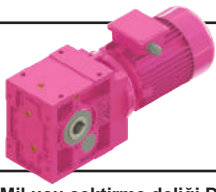

# Ölçü Sayfaları Dimension Pages Abmessungsseiten

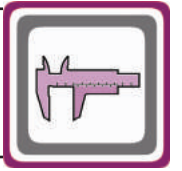

-Mil ucu çektirme deliği DIN 332 sayfa 2 / Tapped center hole to DIN 332, sheet 2 / Zentrierung mit gewinde DIN 332, Blatt 2

## KR673.02

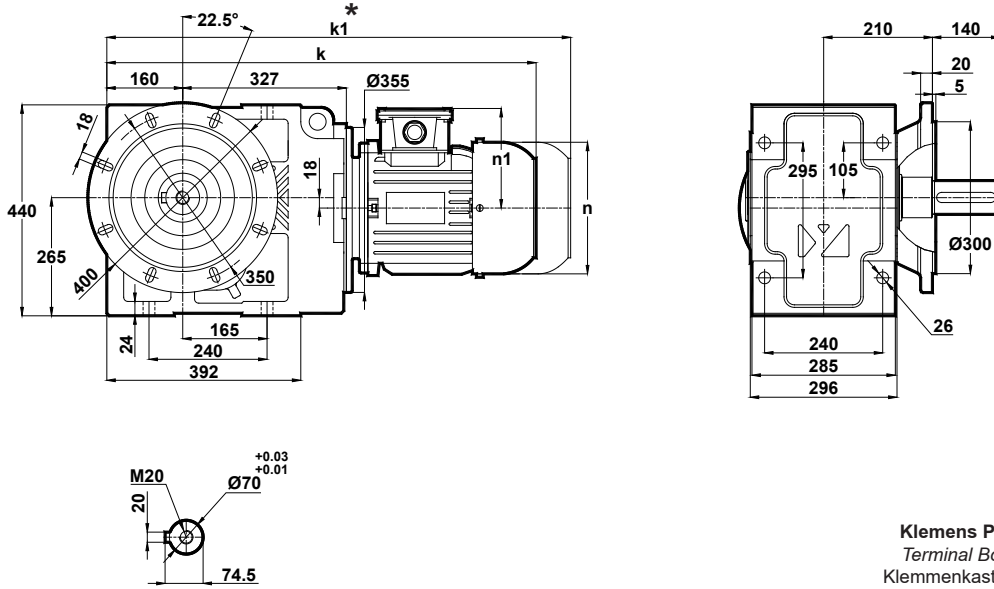

Klemens Pozisyonları  
Terminal Box Positions  
Klemmenkasten Positionen

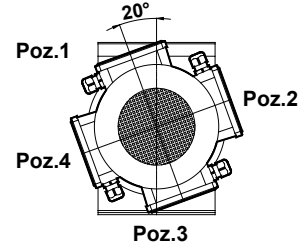

100-112-132-160-180-200-225  
Tip / Type / Typ

	100L	112M	132S	132M	160M	160L	180M	180L	200L	225S	225M
k	790	813	867	905	979	1023	1037	1075	1117	1143	1168
k1	839	948	1012	1050	1149	1193	1207	1245	1317	-	-
n	194	218	258	258	310	310	348	348	390	433	433
n1	135	146	168	168	225	225	241	241	275	285	285

## KR673.03

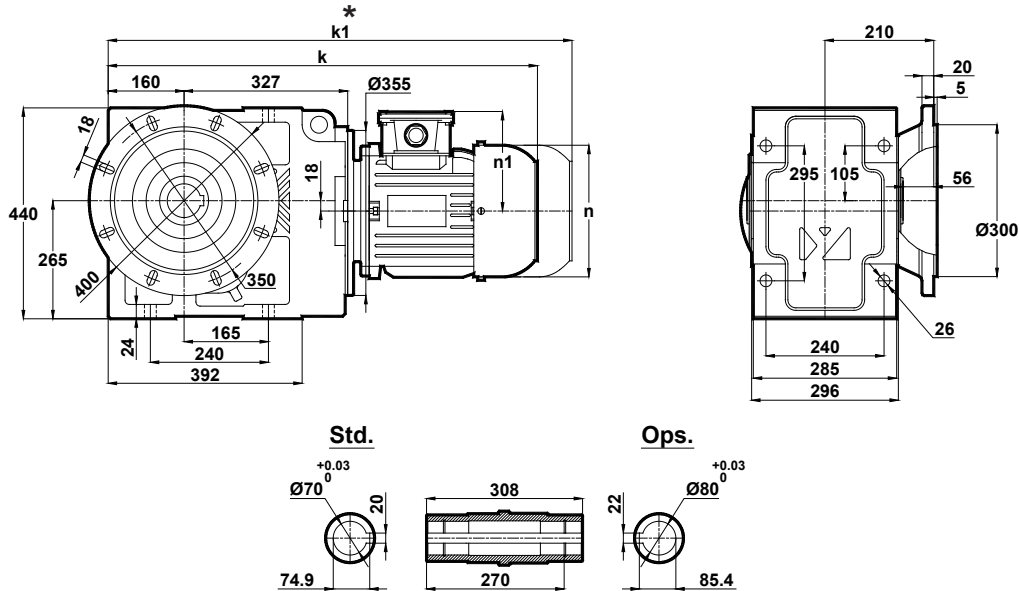

Std.

Ops.

	100L	112M	132S	132M	160M	160L	180M	180L	200L	225S	225M
k	790	813	867	905	979	1023	1037	1075	1117	1143	1168
k1	839	948	1012	1050	1149	1193	1207	1245	1317	-	-
n	194	218	258	258	310	310	348	348	390	433	433
n1	135	146	168	168	225	225	241	241	275	285	285

\* " k1 " Ölçüsü frenli redüktörlere aittir.  
Dimension " k1 " is for motors with brake.  
Maße " k1 " ist für Bremsenmotoren.

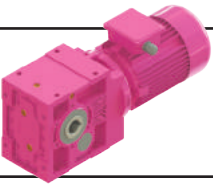

# Ölçü Sayfaları

## Dimension Pages

## Abmessungenseiten

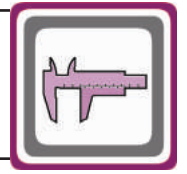

-Mil ucu çektirme deliği DIN 332 sayfa 2 / Tapped center hole to DIN 332, sheet 2 / Zentrierung mit gewinde DIN 332, Blatt 2

### KR673.04

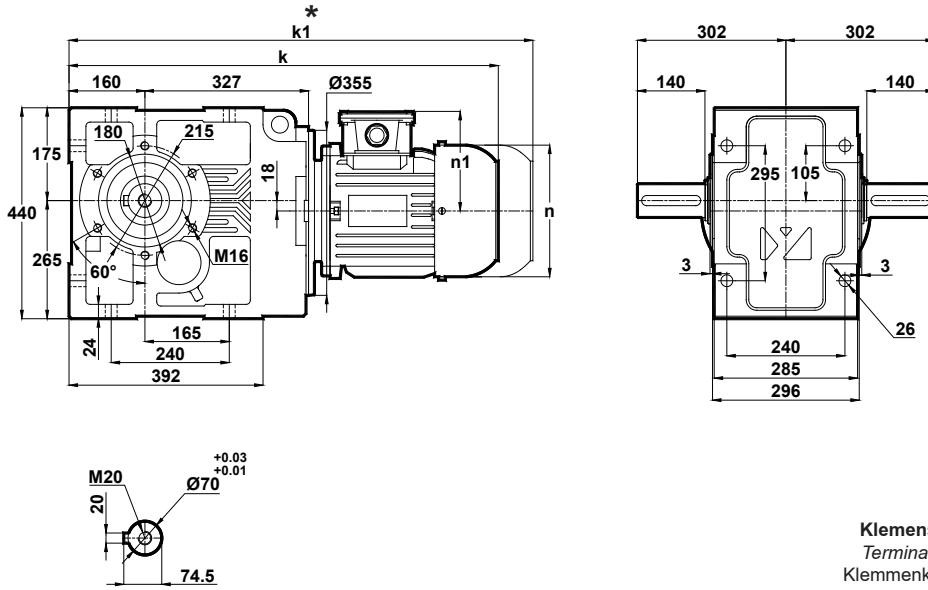

**Klemens Pozisyonları**  
Terminal Box Positions  
Klemmenkasten Positionen

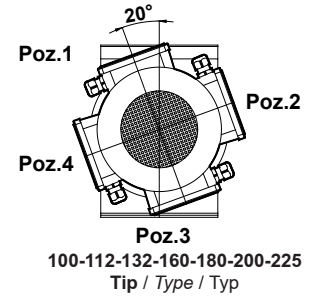

	100L	112M	132S	132M	160M	160L	180M	180L	200L	225S	225M
<b>k</b>	790	813	867	905	979	1023	1037	1075	1117	1143	1168
<b>k1</b>	839	948	1012	1050	1149	1193	1207	1245	1317	-	-
<b>n</b>	194	218	258	258	310	310	348	348	390	433	433
<b>n1</b>	135	146	168	168	225	225	241	241	275	285	285

### KR673.05

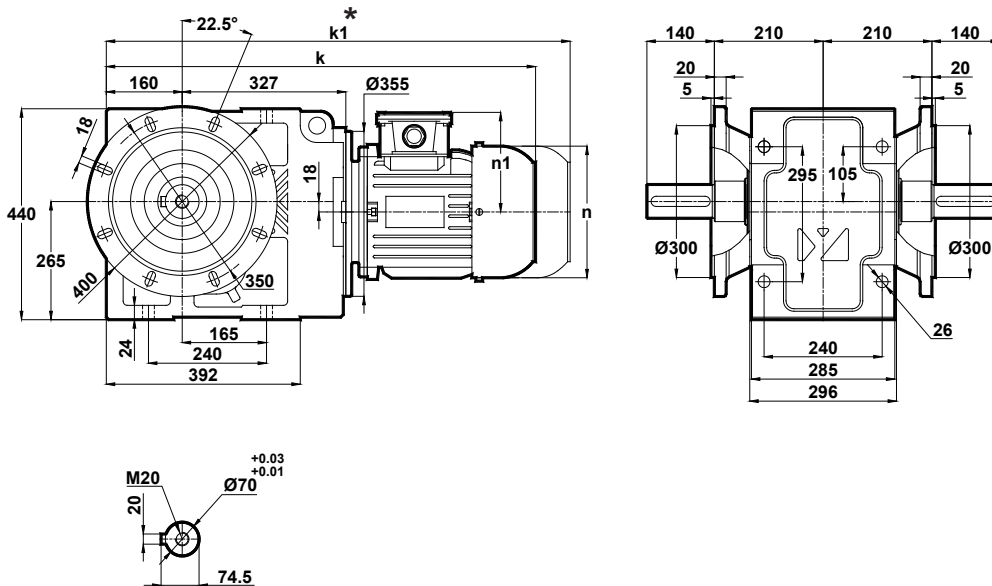

	100L	112M	132S	132M	160M	160L	180M	180L	200L	225S	225M
<b>k</b>	790	813	867	905	979	1023	1037	1075	1117	1143	1168
<b>k1</b>	839	948	1012	1050	1149	1193	1207	1245	1317	-	-
<b>n</b>	194	218	258	258	310	310	348	348	390	433	433
<b>n1</b>	135	146	168	168	225	225	241	241	275	285	285

\* "k1" Ölçüsü frenli redüktörlere aittir.  
Dimension "k1" is for motors with brake.  
Maße "k1" ist für Bremsenmotoren.

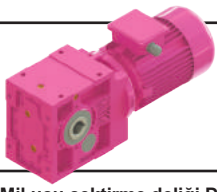

# Ölçü Sayfaları Dimension Pages Abmessungenseiten

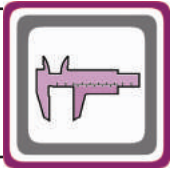

-Mil ucu çektirme deliği DIN 332 sayfa 2 / Tapped center hole to DIN 332, sheet 2 / Zentrierung mit gewinde DIN 332, Blatt 2

KR673.08

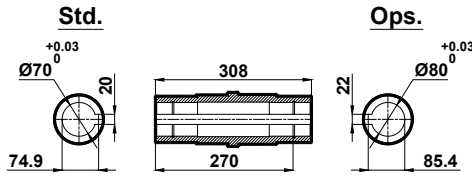
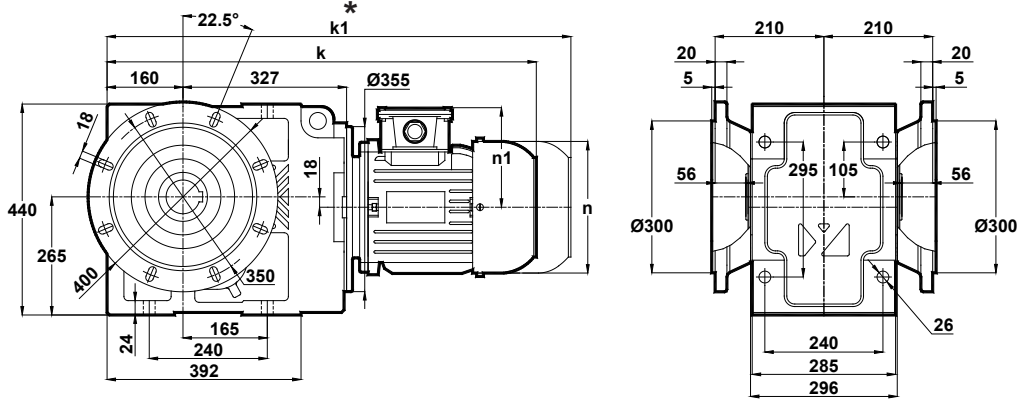

Klemens Pozisyonları  
Terminal Box Positions  
Klemmenkasten Positionen

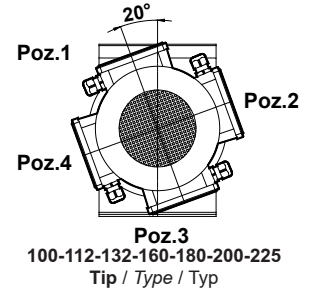

	100L	112M	132S	132M	160M	160L	180M	180L	200L	225S	225M
k	790	813	867	905	979	1023	1037	1075	1117	1143	1168
k1	839	948	1012	1050	1149	1193	1207	1245	1317	-	-
n	194	218	258	258	310	310	348	348	390	433	433
n1	135	146	168	168	225	225	241	241	275	285	285

\* " k1 " Ölçüsü frenli redüktörlere aittir.  
Dimension " k1 " is for motors with brake.  
Maße " k1 " ist für Bremsenmotoren.

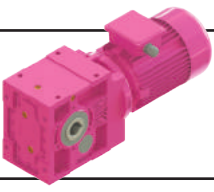

# Ölçü Sayfaları Dimension Pages Abmessungsseiten

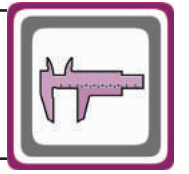

-Mil ucu çekirme deliği DIN 332 sayfa 2 / Tapped center hole to DIN 332, sheet 2 / Zentrierung mit gewinde DIN 332, Blatt 2

## KR674.00

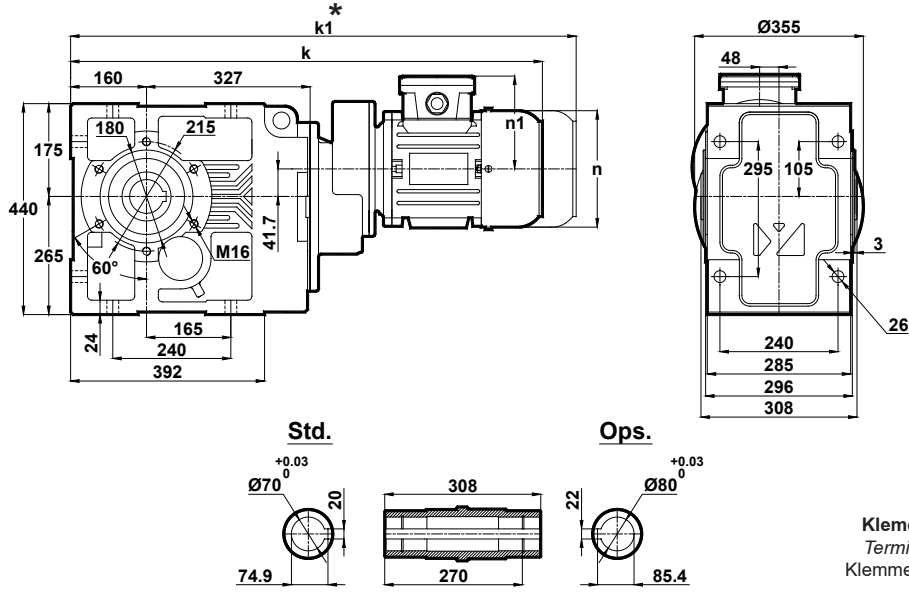

	80	90S	90L	100L
k	815	843	868	906
k1	935	968	993	1041
n	156	176	176	194
n1	118	126	126	135

## KR674.01

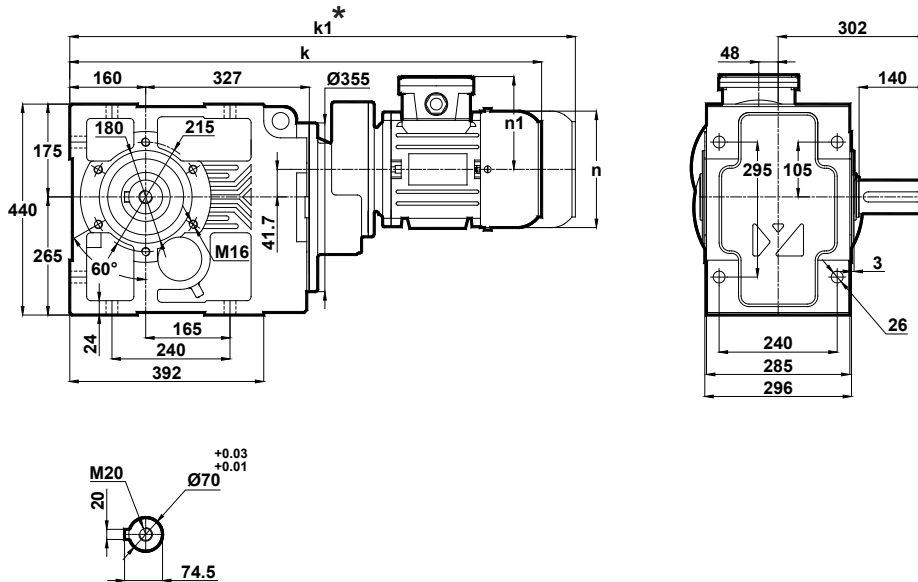

	80	90S	90L	100L
k	815	843	868	906
k1	935	968	993	1041
n	156	176	176	194
n1	118	126	126	135

\* "k1" Ölçüsü frenli redüktörlere aittir.  
Dimension "k1" is for motors with brake.  
Maße "k1" ist für Bremsenmotoren.

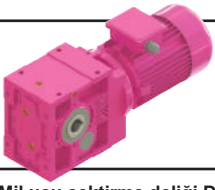

# Ölçü Sayfaları Dimension Pages Abmessungenseiten

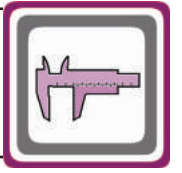

-Mil ucu çektirme deliği DIN 332 sayfa 2 / Tapped center hole to DIN 332, sheet 2 / Zentrierung mit gewinde DIN 332, Blatt 2

## KR674.02

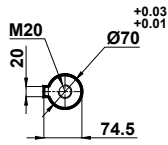
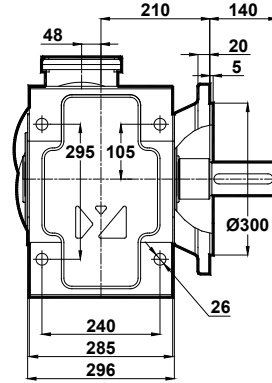
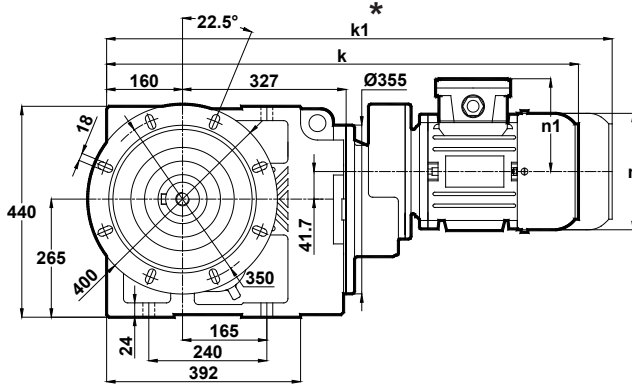

	80	90S	90L	100L
k	815	843	868	906
k1	935	968	993	1041
n	156	176	176	194
n1	118	126	126	135

Klemens Pozisyonları  
Terminal Box Positions  
Klemmenkasten Positionen

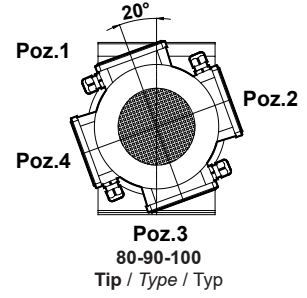

## KR674.03

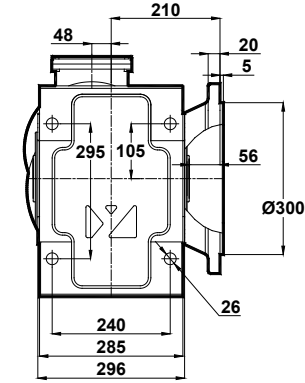
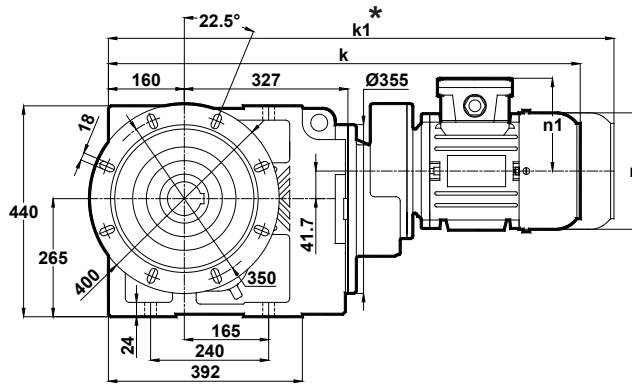

Std.

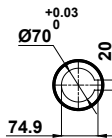

Ops.

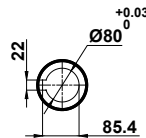

	80	90S	90L	100L
k	815	843	868	906
k1	935	968	993	1041
n	156	176	176	194
n1	118	126	126	135

\* " k1 " Ölçüsü frenli redüktörlere aittir.  
Dimension " k1 " is for motors with brake.  
Maße " k1 " ist für Bremsenmotoren.

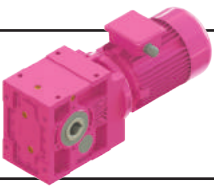

# Ölçü Sayfaları Dimension Pages Abmessungsseiten

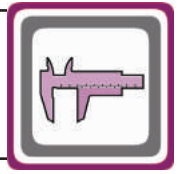

-Mil ucu çekirme deliği DIN 332 sayfa 2 / Tapped center hole to DIN 332, sheet 2 / Zentrierung mit gewinde DIN 332, Blatt 2

## KR674.04

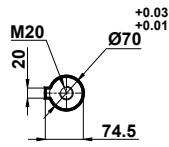
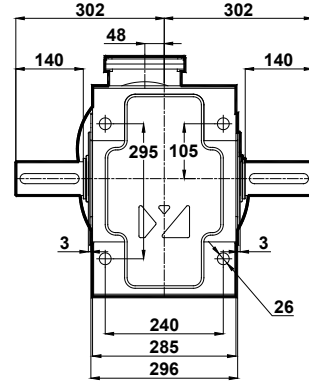
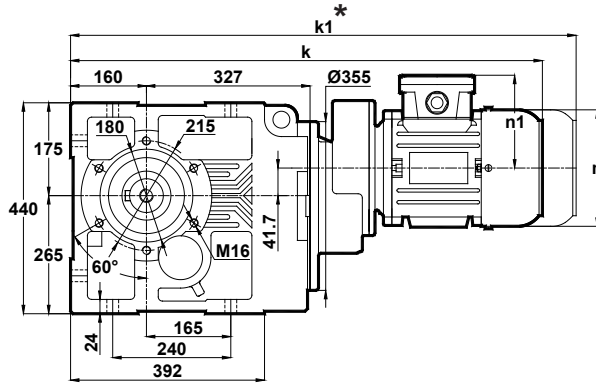

Klemens Pozisyonları  
Terminal Box Positions  
Klemmenkasten Positionen

	80	90S	90L	100L
k	815	843	868	906
k1	935	968	993	1041
n	156	176	176	194
n1	118	126	126	135

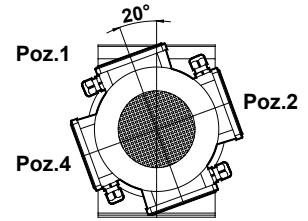

Poz.3  
80-90-100  
Tip / Type / Typ

## KR674.05

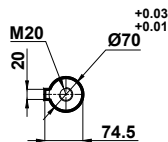
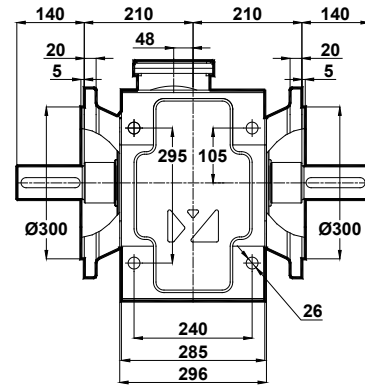
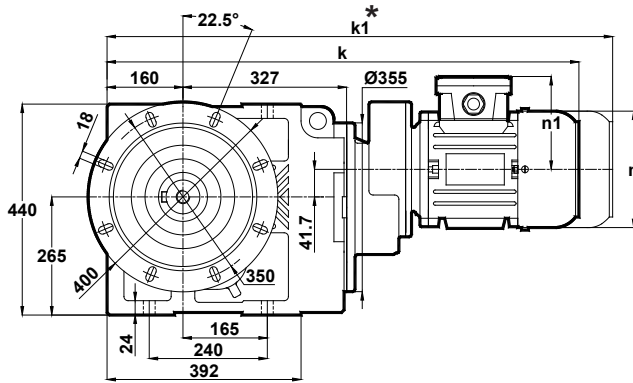

	80	90S	90L	100L
k	815	843	868	906
k1	935	968	993	1041
n	156	176	176	194
n1	118	126	126	135

\* "k1" Ölçüsü frenli redüktörlere aittir.  
Dimension "k1" is for motors with brake.  
Maße "k1" ist für Bremsmotoren.

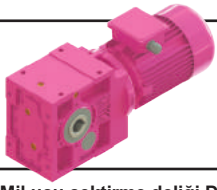

# Ölçü Sayfaları Dimension Pages Abmessungsseiten

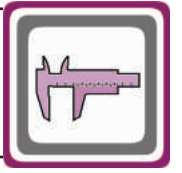

-Mil ucu çektirme deliği DIN 332 sayfa 2 / Tapped center hole to DIN 332, sheet 2 / Zentrierung mit gewinde DIN 332, Blatt 2

KR674.08

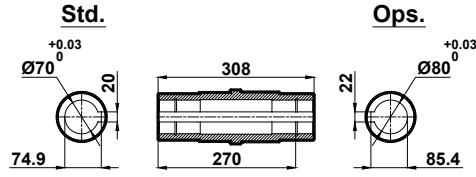
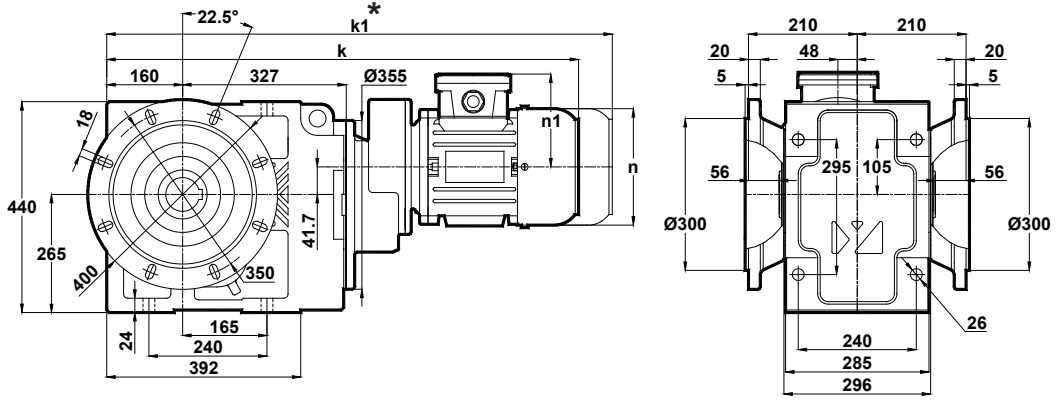

Klemens Pozisyonları  
Terminal Box Positions  
Klemmenkasten Positionen

	80	90S	90L	100L
k	815	843	868	906
k1	935	968	993	1041
n	156	176	176	194
n1	118	126	126	135

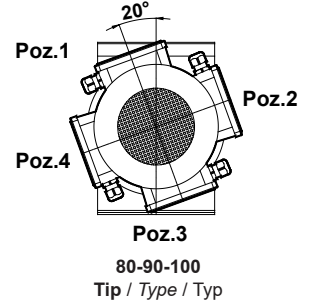

\* " k1 " Ölçüsü frenli redüktörlere aittir.  
Dimension " k1 " is for motors with brake.  
Maße " k1 " ist für Bremsenmotoren.

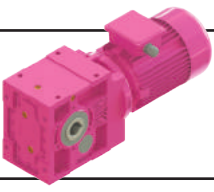

# Ölçü Sayfaları Dimension Pages Abmessungenseiten

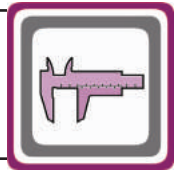

-Mil ucu çekirme deliği DIN 332 sayfa 2 / Tapped center hole to DIN 332, sheet 2 / Zentrierung mit gewinde DIN 332, Blatt 2

KR675.00  
KR676.00

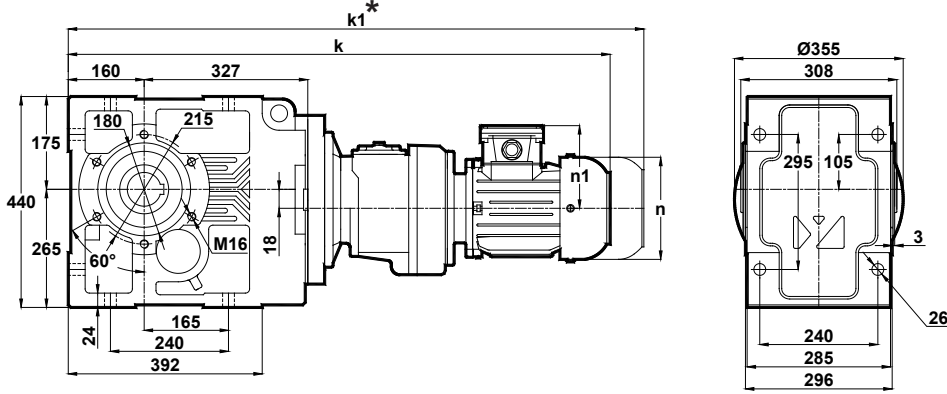

**Std.**

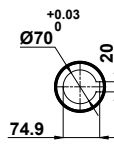

**Ops.**

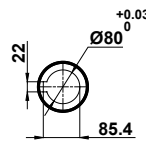

**Klemens Pozisyonları**  
Terminal Box Positions  
Klemmenkasten Positionen

	71	80	90S
k	933	961	990
k1	1053	1081	1115
n	138	156	176
n1	110	118	126

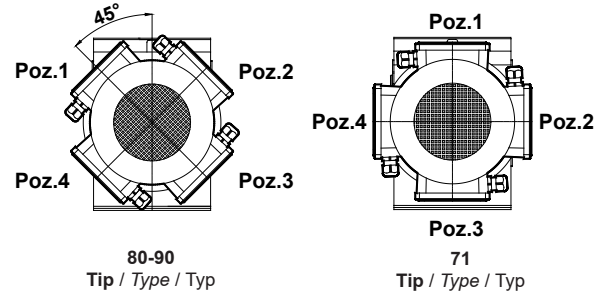

KR675.01  
KR676.01

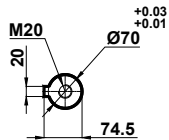
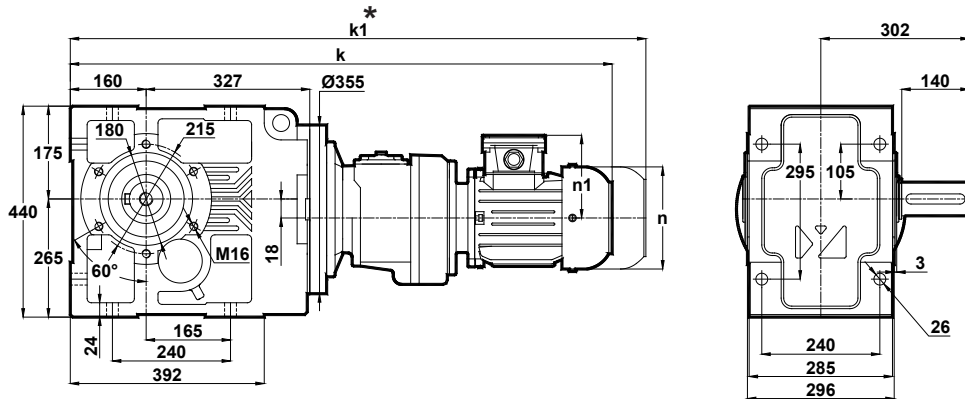

	71	80	90S
k	933	961	990
k1	1053	1081	1115
n	138	156	176
n1	110	118	126

\* "k1" Ölçüsü frenli redüktörlere aittir.  
Dimension "k1" is for motors with brake.  
Maße "k1" ist für Bremsenmotoren.

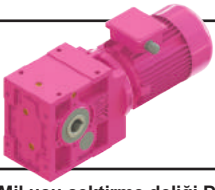

# Ölçü Sayfaları Dimension Pages Abmessungsseiten

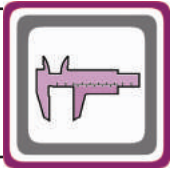

-Mil ucu çekirme deliği DIN 332 sayfa 2 / Tapped center hole to DIN 332, sheet 2 / Zentrierung mit gewinde DIN 332, Blatt 2

KR675.02  
KR676.02

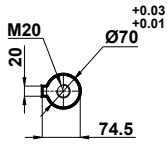
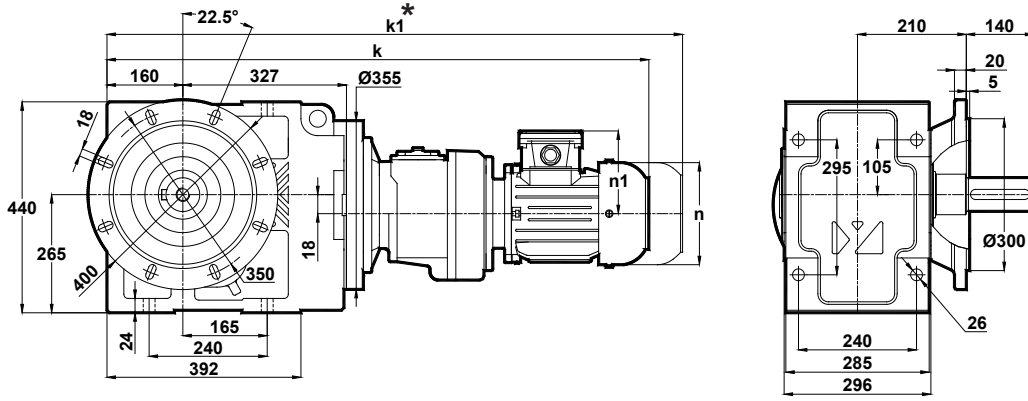

	71	80	90S
k	933	961	990
k1	1053	1081	1115
n	138	156	176
n1	110	118	126

Klemens Pozisyonları  
Terminal Box Positions  
Klemmenkasten Positionen

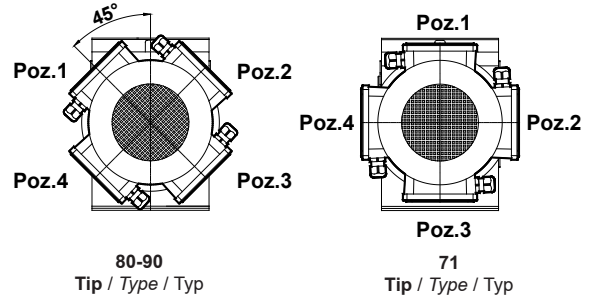

KR675.03  
KR676.03

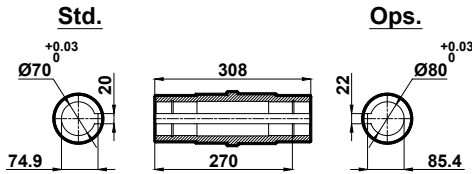
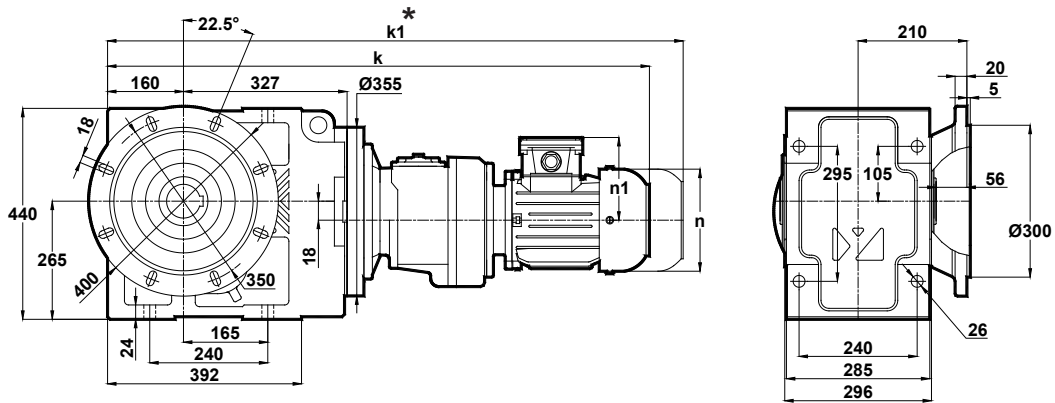

	71	80	90S
k	933	961	990
k1	1053	1081	1115
n	138	156	176
n1	110	118	126

\* " k1 " Ölçüsü frenli redüktörlere aittir.  
Dimension " k1 " is for motors with brake.  
Maße " k1 " ist für Bremsenmotoren.

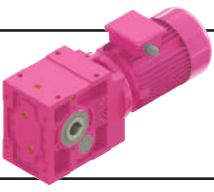

# Ölçü Sayfaları Dimension Pages Abmessungsseiten

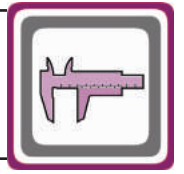

-Mil ucu çektirme deliği DIN 332 sayfa 2 / Tapped center hole to DIN 332, sheet 2 / Zentrierung mit gewinde DIN 332, Blatt 2

KR675.04  
KR676.04

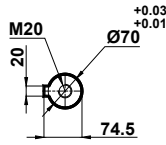
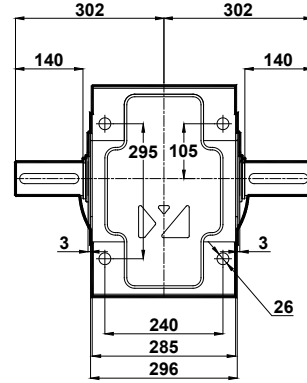
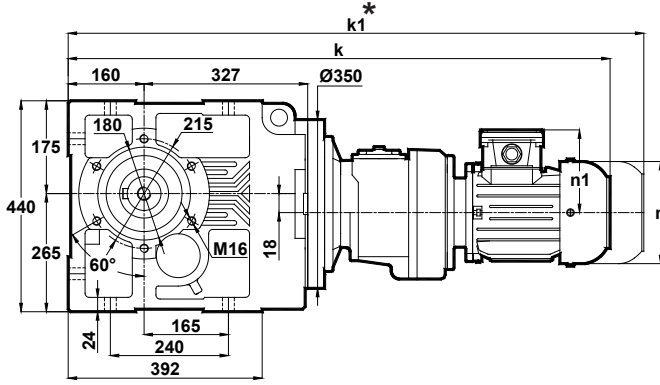

	71	80	90S
k	933	961	990
k1	1053	1081	1115
n	138	156	176
n1	110	118	126

Klemens Pozisyonları  
Terminal Box Positions  
Klemmenkasten Positionen

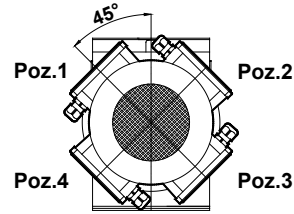

80-90  
Tip / Type / Typ

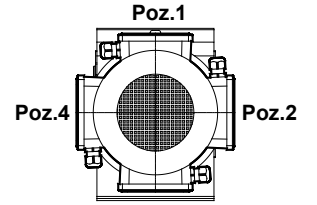

71  
Tip / Type / Typ

KR675.05  
KR676.05

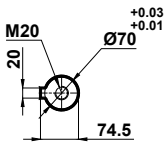
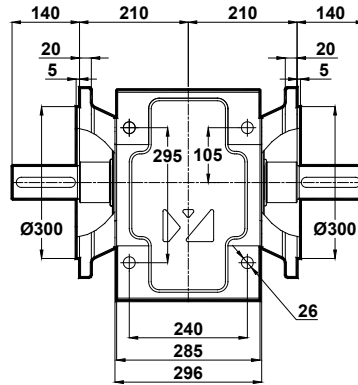
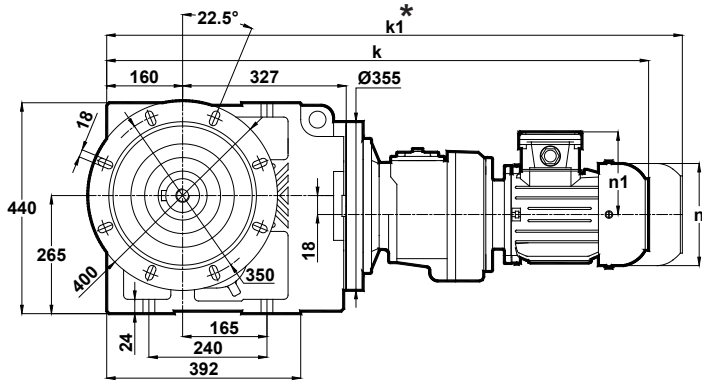

	71	80	90S
k	933	961	990
k1	1053	1081	1115
n	138	156	176
n1	110	118	126

\* " k1 " Ölçüsü frenli redüktörlere aittir.  
Dimension " k1 " is for motors with brake.  
Maße " k1 " ist für Bremsenmotoren.

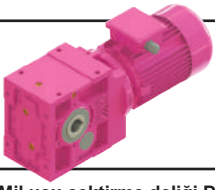

# Ölçü Sayfaları Dimension Pages Abmessungsseiten

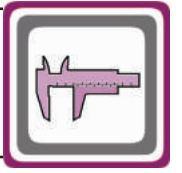

-Mil ucu çektirme deliği DIN 332 sayfa 2 / Tapped center hole to DIN 332, sheet 2 / Zentrierung mit gewinde DIN 332, Blatt 2

KR675.08  
KR676.08

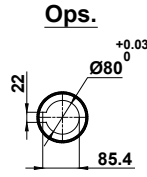
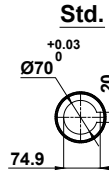
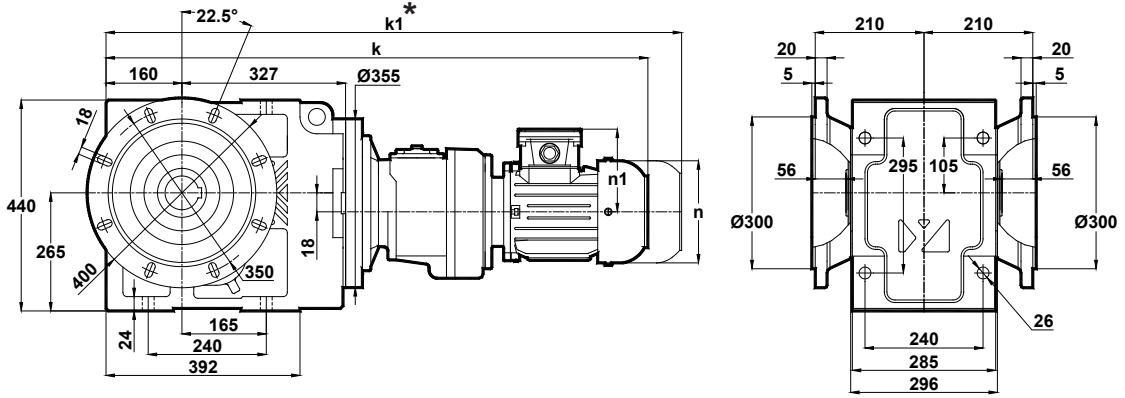

**Klemens Pozisyonları**  
Terminal Box Positions  
Klemmenkasten Positionen

	71	80	90S
k	933	961	990
k1	1053	1081	1115
n	138	156	176
n1	110	118	126

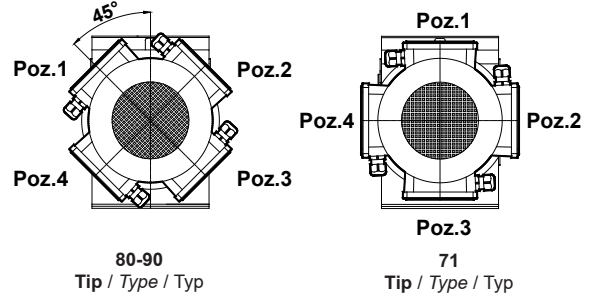

80-90  
Tip / Type / Typ

71  
Tip / Type / Typ

\* " k1 " Ölçüsü frenli redüktörlere aittir.  
Dimension " k1 " is for motors with brake.  
Maße " k1 " ist für Bremsenmotoren.

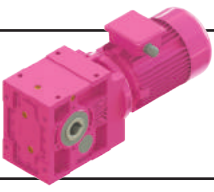

# Ölçü Sayfaları Dimension Pages Abmessungsseiten

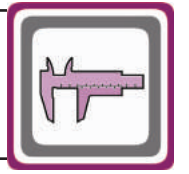

-Mil ucu çektirme deliği DIN 332 sayfa 2 / Tapped center hole to DIN 332, sheet 2 / Zentrierung mit gewinde DIN 332, Blatt 2

## KR773.00

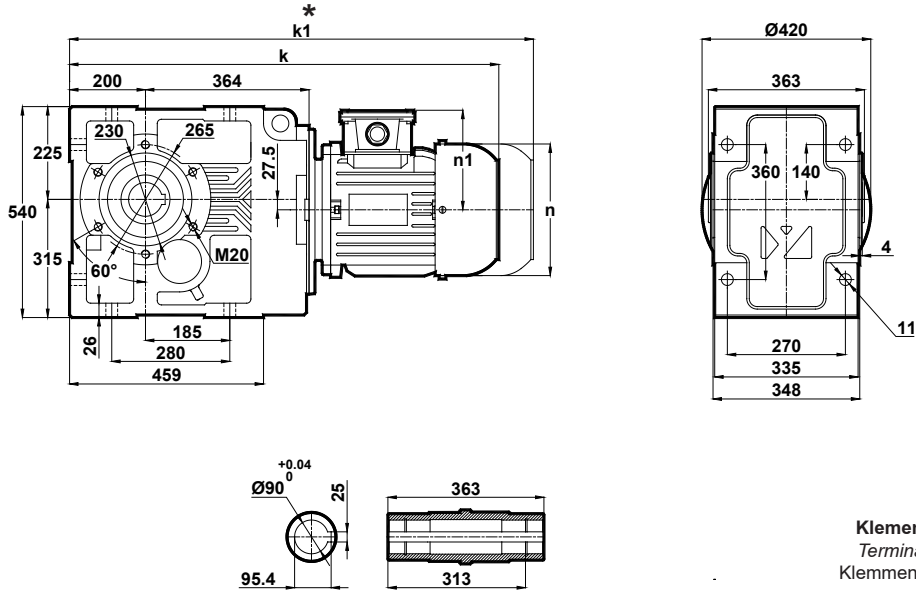

Klemens Pozisyonları  
Terminal Box Positions  
Klemmenkasten Positionen

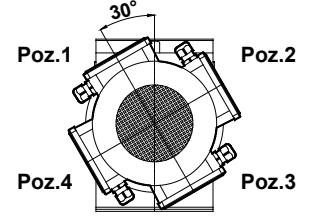

132-160-180-200-225-250  
Tip / Type / Typ

	132S	132M	160M	160L	180M	180L	200L	225S	225M	250M
k	938	976	1052	1096	1113	1151	1190	1217	1242	1346
k1	1083	1121	1222	1266	1283	1321	1390	-	-	-
n	258	258	310	310	348	348	390	433	433	480
n1	168	168	225	225	241	241	275	285	285	322

## KR773.01

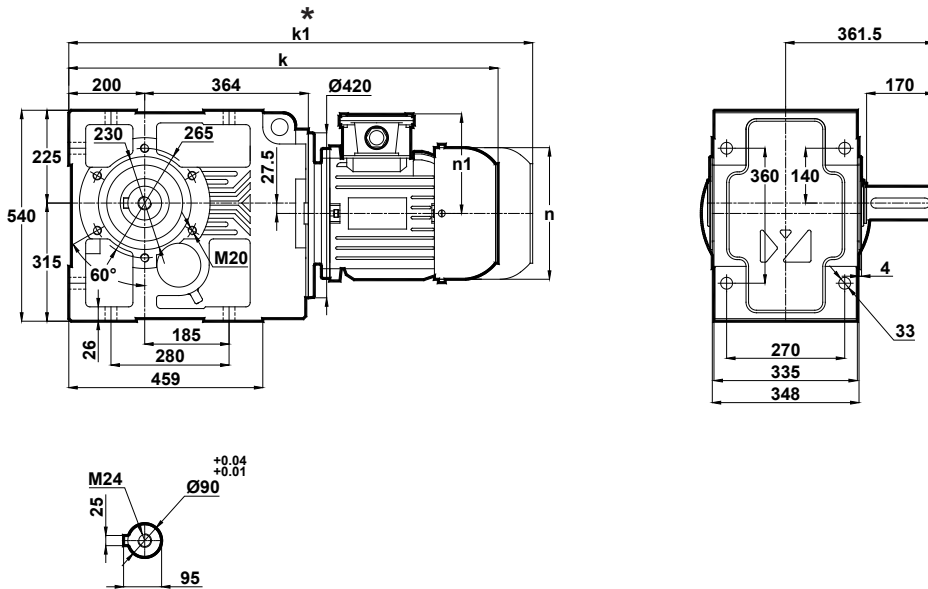

	132S	132M	160M	160L	180M	180L	200L	225S	225M	250M
k	938	976	1052	1096	1113	1151	1190	1217	1242	1346
k1	1083	11521	1222	1266	1283	1321	1390	-	-	-
n	258	258	310	310	348	348	390	433	433	480
n1	168	168	225	225	241	241	275	285	285	322

\* "k1" Ölçüsü frenli redüktörlere aittir.  
Dimension "k1" is for motors with brake.  
Maße "k1" ist für Bremsenmotoren.

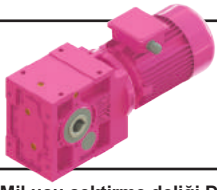

# Ölçü Sayfaları Dimension Pages Abmessungsseiten

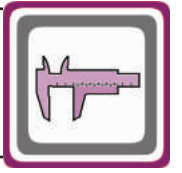

-Mil ucu çektirme deliği DIN 332 sayfa 2 / Tapped center hole to DIN 332, sheet 2 / Zentrierung mit gewinde DIN 332, Blatt 2

## KR773.02

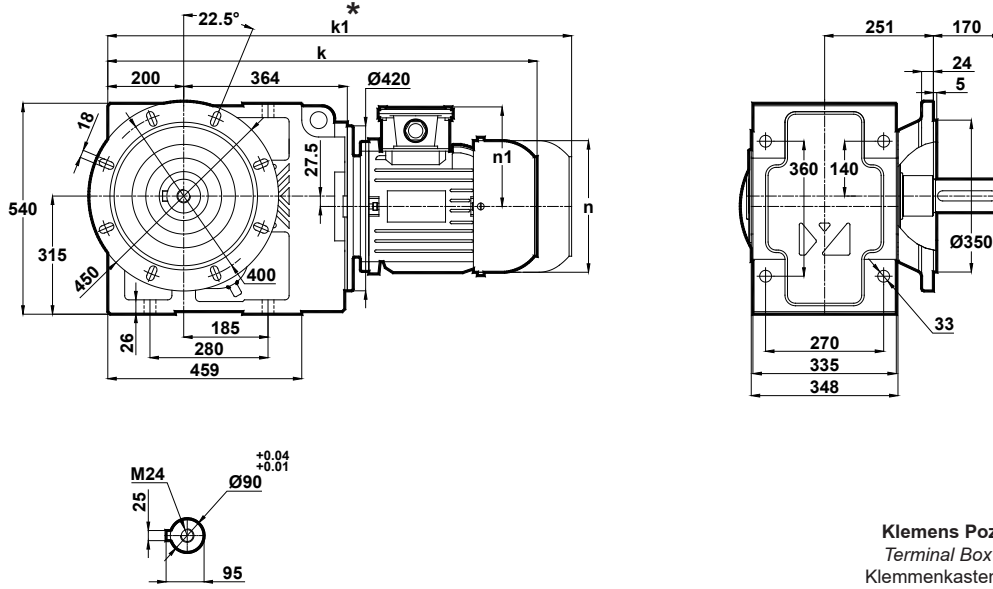

Klemens Pozisyonları  
Terminal Box Positions  
Klemmenkasten Positionen

	132S	132M	160M	160L	180M	180L	200L	225S	225M	250M
k	938	976	1052	1096	1113	1151	1190	1217	1242	1346
k1	1083	1121	1222	1266	1283	1321	1390	-	-	-
n	258	258	310	310	348	348	390	433	433	480
n1	168	168	225	225	241	241	275	285	285	322

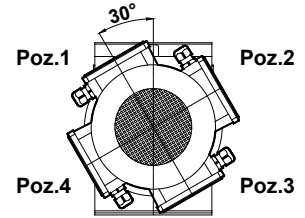

132-160-180-200-225-250  
Tip / Type / Typ

## KR773.03

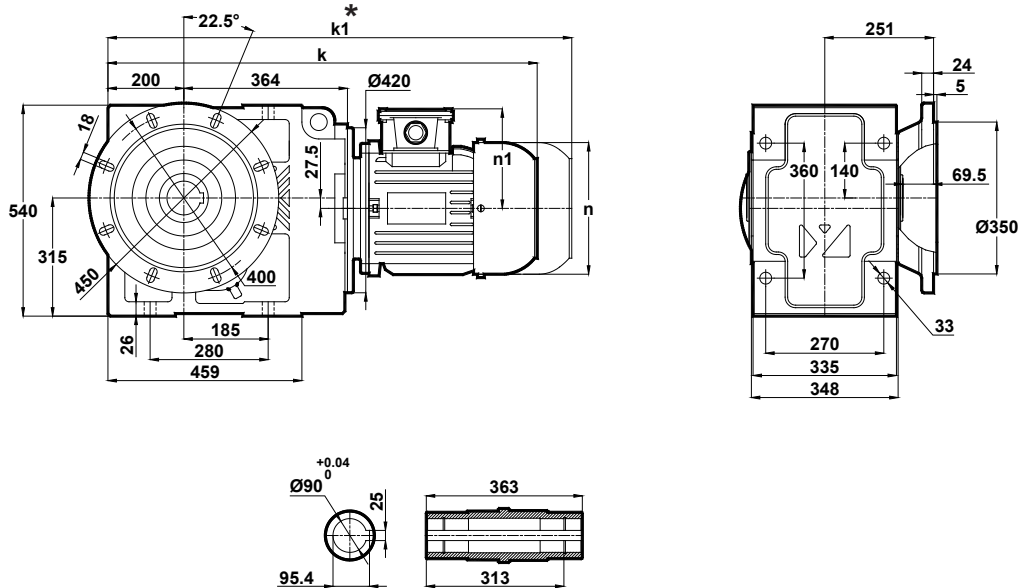

	132S	132M	160M	160L	180M	180L	200L	225S	225M	250M
k	938	976	1052	1096	1113	1151	1190	1217	1242	1346
k1	1083	1121	1222	1266	1283	1321	1390	-	-	-
n	258	258	310	310	348	348	390	433	433	480
n1	168	168	225	225	241	241	275	285	285	322

\* " k1 " Ölçüsü frenli redüktörlere aittir.  
Dimension " k1 " is for motors with brake.  
Maße " k1 " ist für Bremsenmotoren.

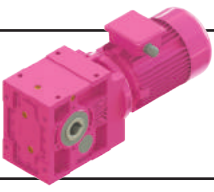

# Ölçü Sayfaları Dimension Pages Abmessungenseiten

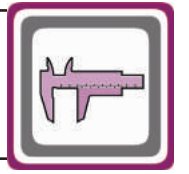

-Mil ucu çektirme deliği DIN 332 sayfa 2 / Tapped center hole to DIN 332, sheet 2 / Zentrierung mit gewinde DIN 332, Blatt 2

## KR773.04

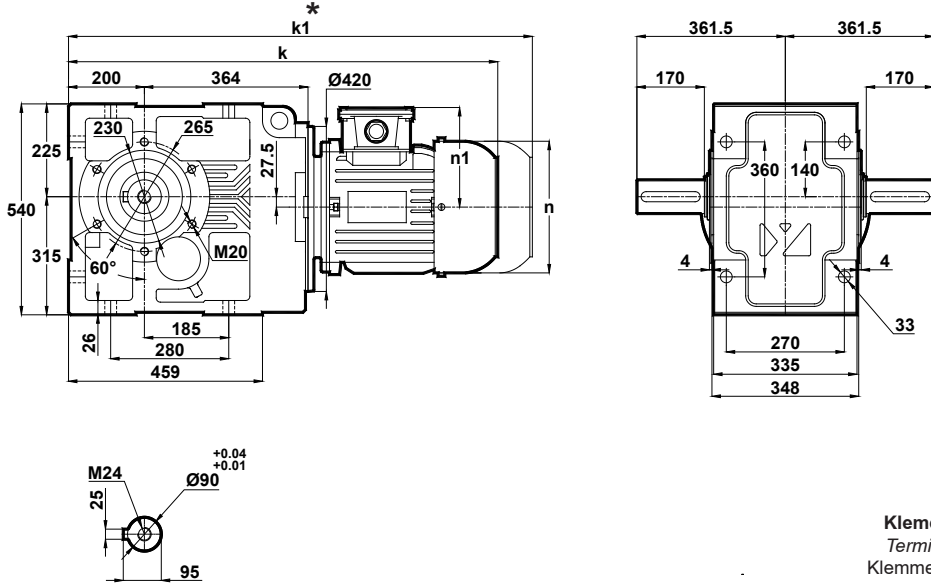

Klemens Pozisyonları  
Terminal Box Positions  
Klemmenkasten Positionen

	132S	132M	160M	160L	180M	180L	200L	225S	225M	250M
k	938	976	1052	1096	1113	1151	1190	1217	1242	1346
k1	1083	1121	1222	1266	1283	1321	1390	-	-	-
n	258	258	310	310	348	348	390	433	433	480
n1	168	168	225	225	241	241	275	285	285	322

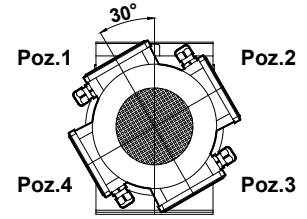

132-160-180-200-225-250  
Tip / Type / Typ

## KR773.05

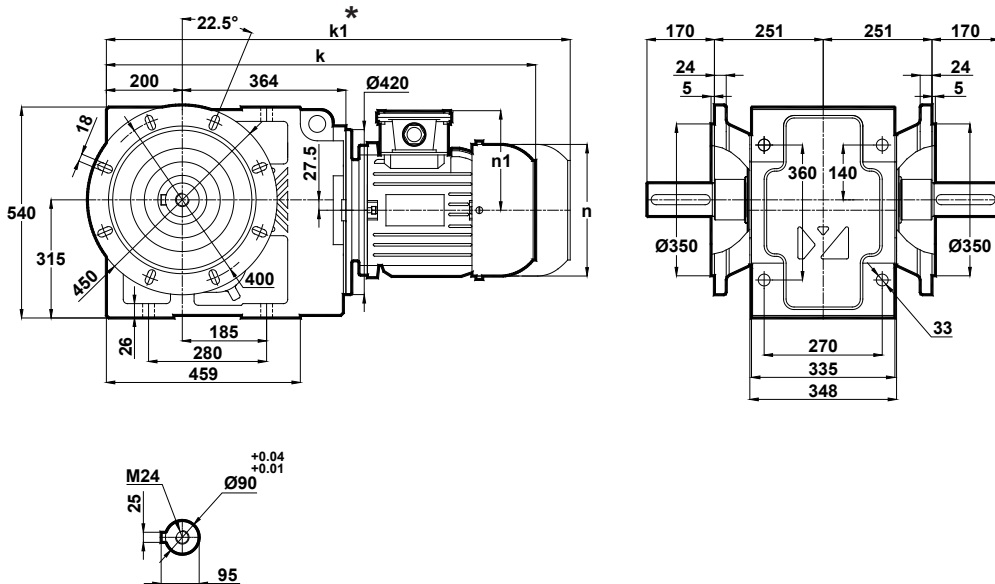

	132S	132M	160M	160L	180M	180L	200L	225S	225M	250M
k	938	976	1052	1096	1113	1151	1190	1217	1242	1346
k1	1083	1121	1222	1266	1283	1321	1390	-	-	-
n	258	258	310	310	348	348	390	433	433	480
n1	168	168	225	225	241	241	275	285	285	322

\* "k1" Ölçüsü frenli redüktörlere aittir.  
Dimension "k1" is for motors with brake.  
Maße "k1" ist für Bremsenmotoren.

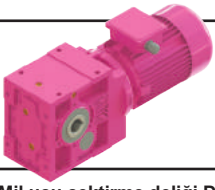

# Ölçü Sayfaları Dimension Pages Abmessungsseiten

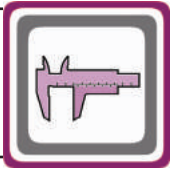

-Mil ucu çektirme deliği DIN 332 sayfa 2 / Tapped center hole to DIN 332, sheet 2 / Zentrierung mit gewinde DIN 332, Blatt 2

KR773.08

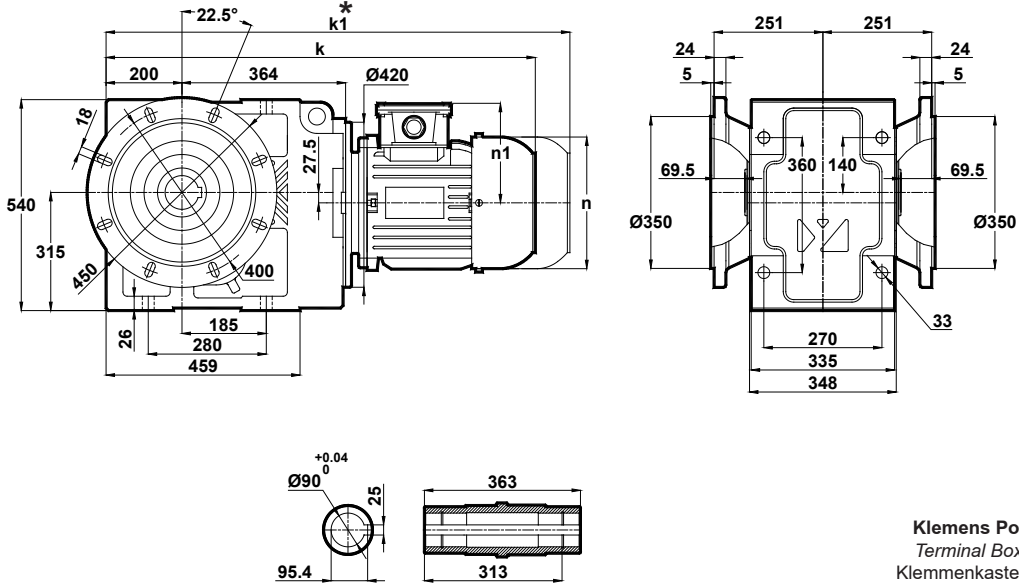

Klemens Pozisyonları  
Terminal Box Positions  
Klemmenkasten Positionen

	132S	132M	160M	160L	180M	180L	200L	225S	225M	250M
k	938	976	1052	1096	1113	1151	1190	1217	1242	1346
k1	1083	1121	1222	1266	1283	1321	1390	-	-	-
n	258	258	310	310	348	348	390	433	433	480
n1	168	168	225	225	241	241	275	285	285	322

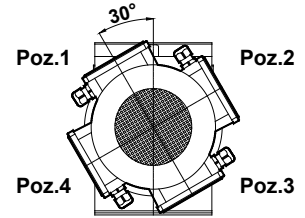

132-160-180-200-225-250  
Tip / Type / Typ

\* " k1 " Ölçüsü frenli redüktörlere aittir.  
Dimension " k1 " is for motors with brake.  
Maße " k1 " ist für Bremsenmotoren.

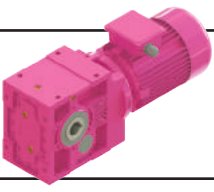

# Ölçü Sayfaları Dimension Pages Abmessungsseiten

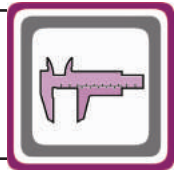

-Mil ucu çekirme deliği DIN 332 sayfa 2 / Tapped center hole to DIN 332, sheet 2 / Zentrierung mit gewinde DIN 332, Blatt 2

## KR774.00

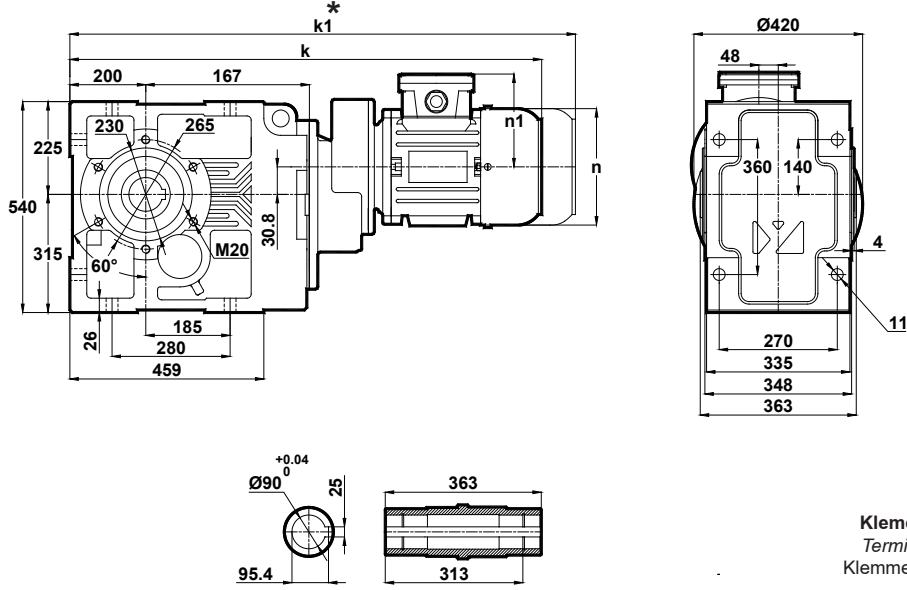

Klemens Pozisyonları  
Terminal Box Positions  
Klemmenkasten Positionen

	90S	90L	100L	112M	132S	132M
k	908	945	971	1001	1046	1096
k1	1033	1070	1106	1136	1191	1241
n	176	176	194	218	258	258
n1	126	126	135	146	168	168

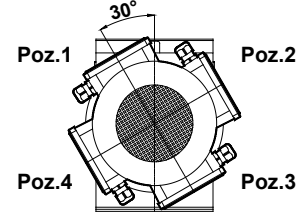

90-100-112-132  
Tip / Tvpe / Tvø

## KR774.01

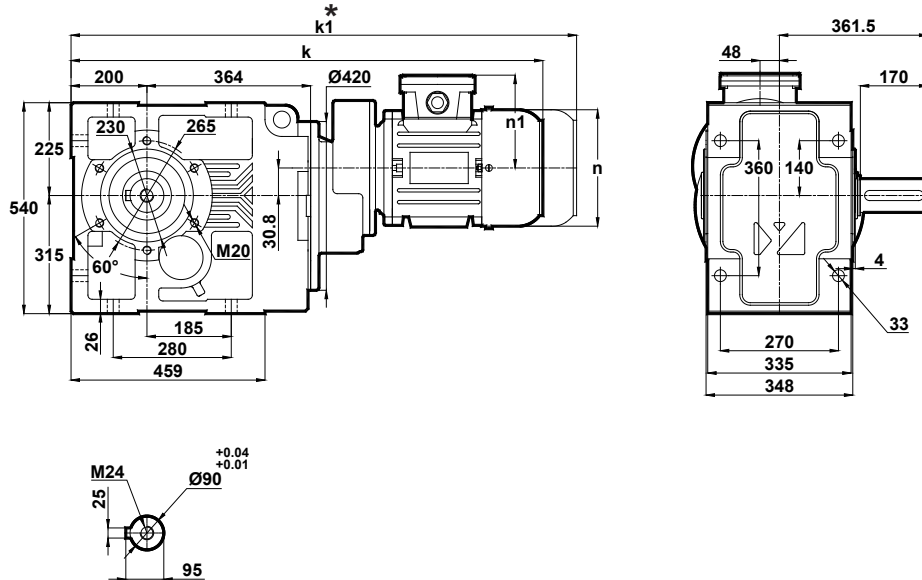

	90S	90L	100L	112M	132S	132M
k	908	945	971	1001	1046	1096
k1	1033	1070	1106	1136	1191	1241
n	176	176	194	218	258	258
n1	126	126	135	146	168	168

\* "k1" Ölçüsü frenli redüktörlere aittir.  
Dimension "k1" is for motors with brake.  
Maße "k1" ist für Bremsenmotoren.

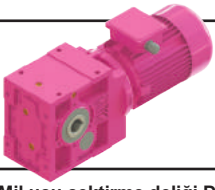

# Ölçü Sayfaları Dimension Pages Abmessungsseiten

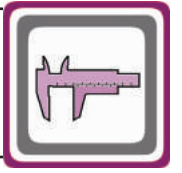

-Mil ucu çektirme deliği DIN 332 sayfa 2 / Tapped center hole to DIN 332, sheet 2 / Zentrierung mit gewinde DIN 332, Blatt 2

## KR774.02

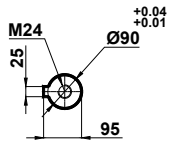
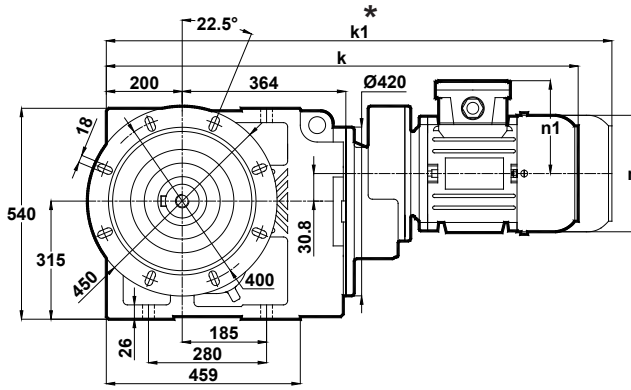

	90S	90L	100L	112M	132S	132M
k	908	945	971	1001	1046	1096
k1	1033	1070	1106	1136	1191	1241
n	176	176	194	218	258	258
n1	126	126	135	146	168	168

Klemens Pozisyonları  
Terminal Box Positions  
Klemmenkasten Positionen

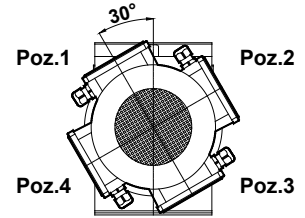

90-100-112-132  
Tip / Type / Typ

## KR774.03

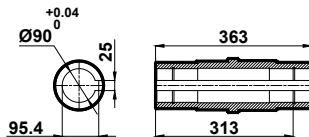
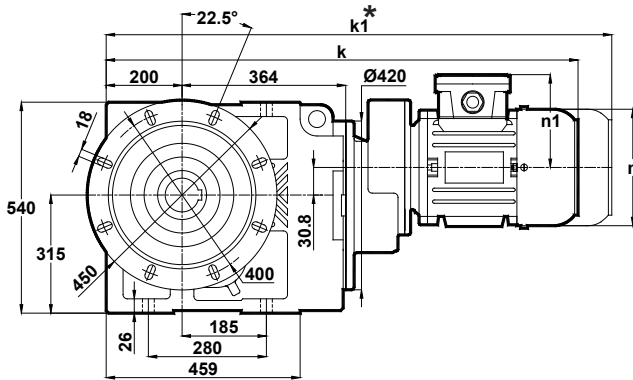

	90S	90L	100L	112M	132S	132M
k	908	945	971	1001	1046	1096
k1	1033	1070	1106	1136	1191	1241
n	176	176	194	218	258	258
n1	126	126	135	146	168	168

\* " k1 " Ölçüsü frenli redüktörlere aittir.  
Dimension " k1 " is for motors with brake.  
Maße " k1 " ist für Bremsenmotoren.

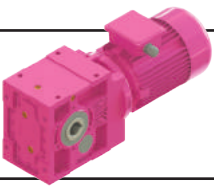

# Ölçü Sayfaları Dimension Pages Abmessungsseiten

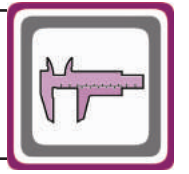

-Mil ucu çektirme deliği DIN 332 sayfa 2 / Tapped center hole to DIN 332, sheet 2 / Zentrierung mit gewinde DIN 332, Blatt 2

## KR774.04

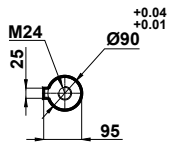
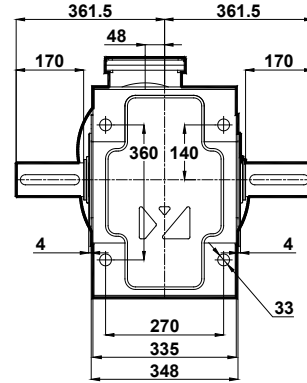
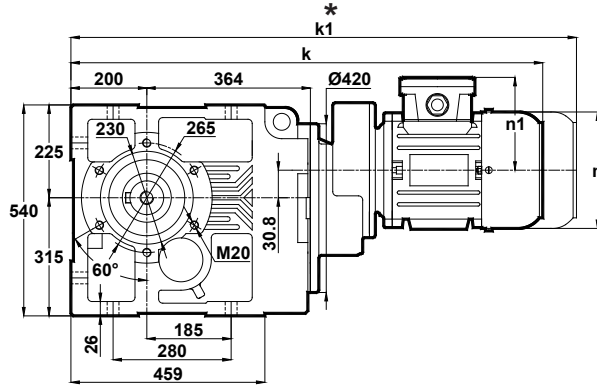

**Klemens Pozisyonları**  
Terminal Box Positions  
Klemmenkasten Positionen

	90S	90L	100L	112M	132S	132M
k	908	945	971	1001	1046	1096
k1	1033	1070	1106	1136	1191	1241
n	176	176	194	218	258	258
n1	126	126	135	146	168	168

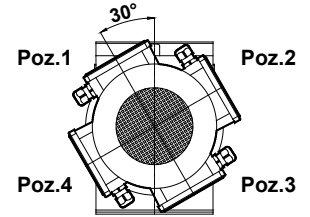

90-100-112-132  
Tip / Type / Typ

## KR774.05

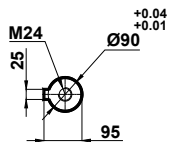
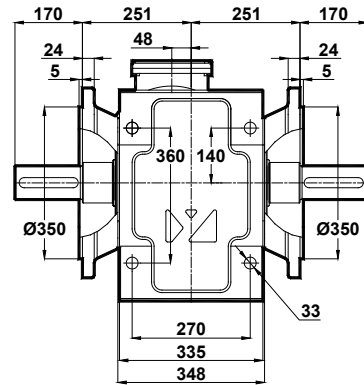
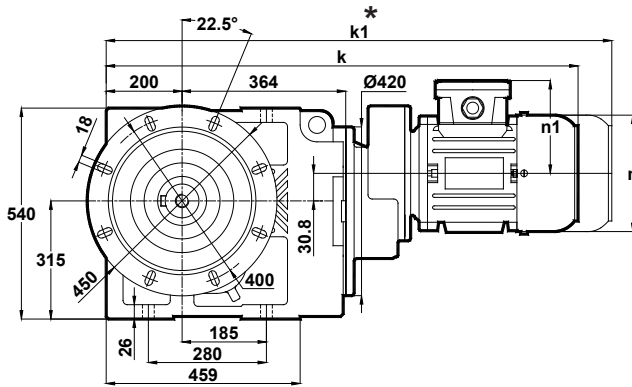

	90S	90L	100L	112M	132S	132M
k	908	945	971	1001	1046	1096
k1	1033	1070	1106	1136	1191	1241
n	176	176	194	218	258	258
n1	126	126	135	146	168	168

\* "k1" Ölçüsü frenli redüktörlere aittir.  
Dimension "k1" is for motors with brake.  
Maße "k1" ist für Bremsenmotoren.

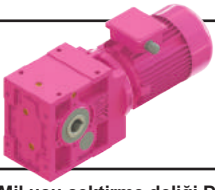

# Ölçü Sayfaları Dimension Pages Abmessungsseiten

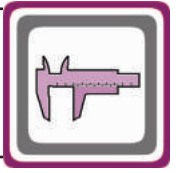

-Mil ucu çektirme deliği DIN 332 sayfa 2 / Tapped center hole to DIN 332, sheet 2 / Zentrierung mit gewinde DIN 332, Blatt 2

KR774.08

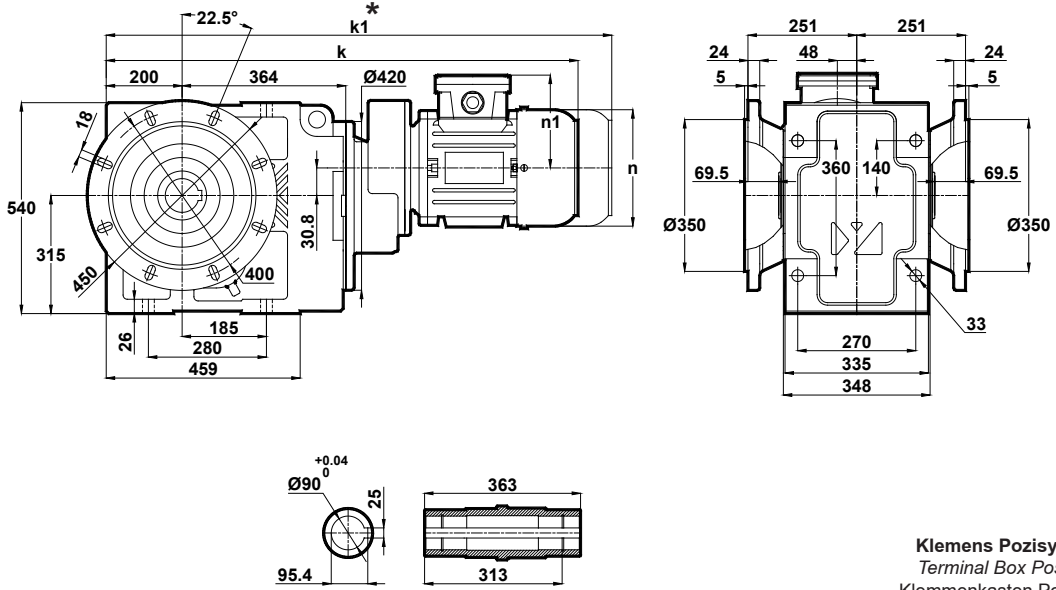

	90S	90L	100L	112M	132S	132M
k	908	945	971	1001	1046	1096
k1	1033	1070	1106	1136	1191	1241
n	176	176	194	218	258	258
n1	126	126	135	146	168	168

Klemens Pozisyonları  
Terminal Box Positions  
Klemmenkasten Positionen

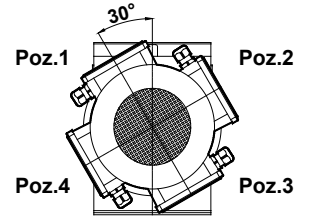

90-100-112-132  
Tip / Type / Typ

\* " k1 " Ölçüsü frenli redüktörlere aittir.  
Dimension " k1 " is for motors with brake.  
Maße " k1 " ist für Bremsenmotoren.

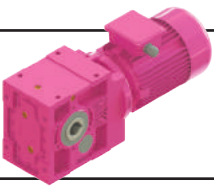

# Ölçü Sayfaları Dimension Pages Abmessungsseiten

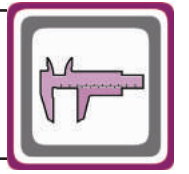

-Mil ucu çektirme deliği DIN 332 sayfa 2 / Tapped center hole to DIN 332, sheet 2 / Zentrierung mit gewinde DIN 332, Blatt 2

KR775.00  
KR776.00

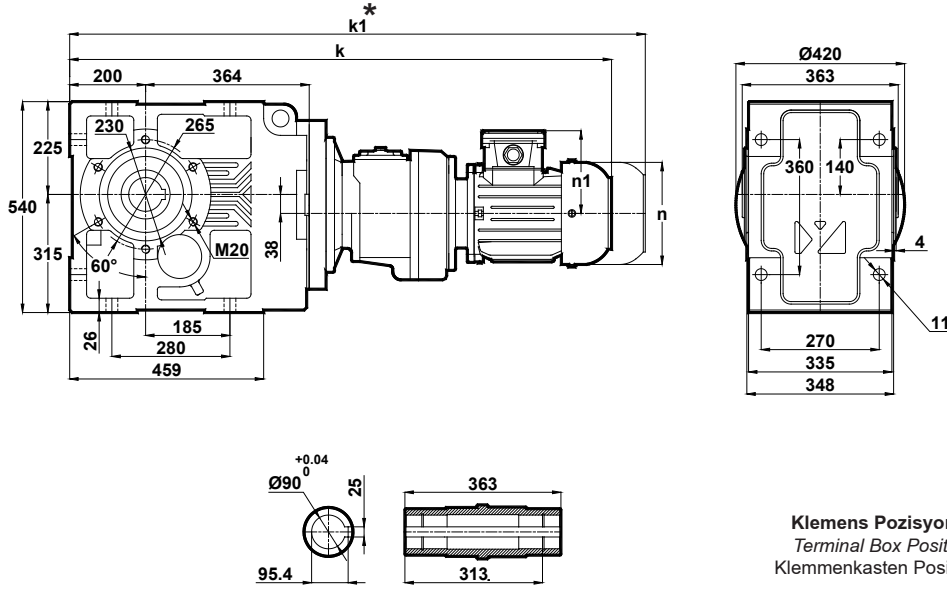

Klemens Pozisyonları  
Terminal Box Positions  
Klemmenkasten Positionen

	71	80	90S	90L	100L
k	1010	1038	1067	1092	1132
k1	1130	1158	1192	1217	1267
n	138	156	176	176	194
n1	110	118	126	126	135

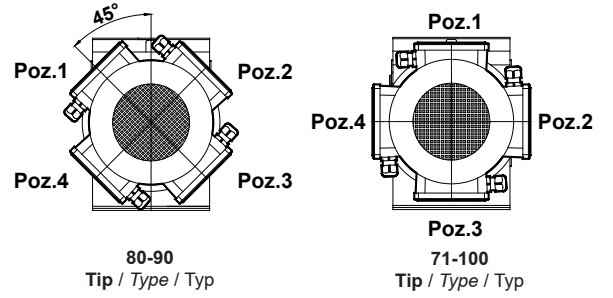

KR775.01  
KR776.01

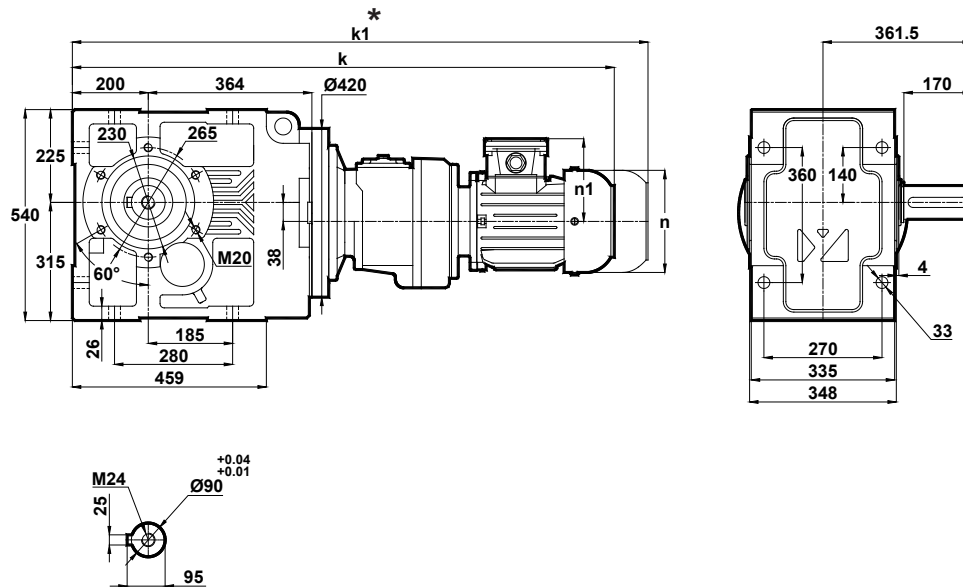

	71	80	90S	90L	100L
k	1010	1038	1067	1092	1132
k1	1130	1158	1192	1217	1267
n	138	156	176	176	194
n1	110	118	126	126	135

\* "k1" Ölçüsü frenli redüktörlere aittir.  
Dimension "k1" is for motors with brake.  
Maße "k1" ist für Bremsenmotoren.

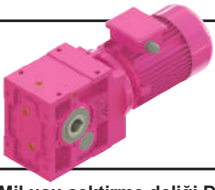

# Ölçü Sayfaları Dimension Pages Abmessungsseiten

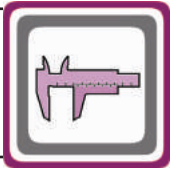

-Mil ucu çektirme deliği DIN 332 sayfa 2 / Tapped center hole to DIN 332, sheet 2 / Zentrierung mit gewinde DIN 332, Blatt 2

KR775.02  
KR776.02

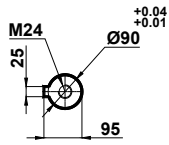
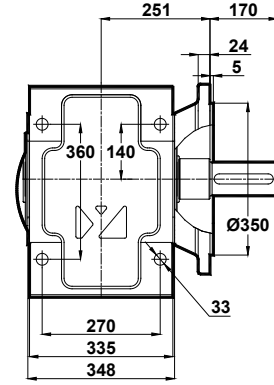
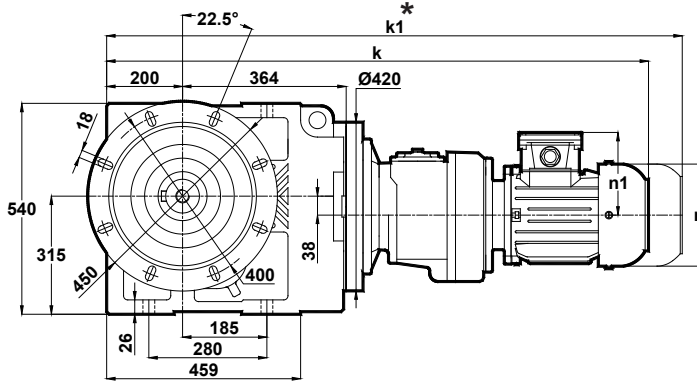

Klemens Pozisyonları  
Terminal Box Positions  
Klemmenkasten Positionen

	71	80	90S	90L	100L
k	1010	1038	1067	1092	1132
k1	1130	1158	1192	1217	1267
n	138	156	176	176	194
n1	110	118	126	126	135

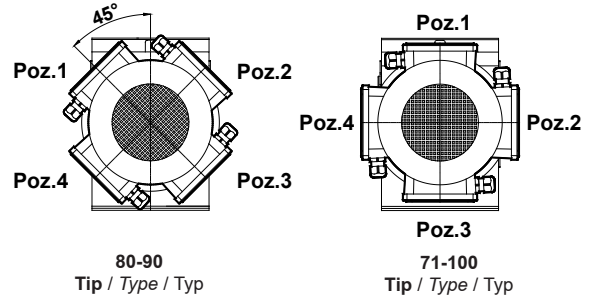

KR775.03  
KR776.03

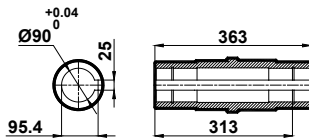
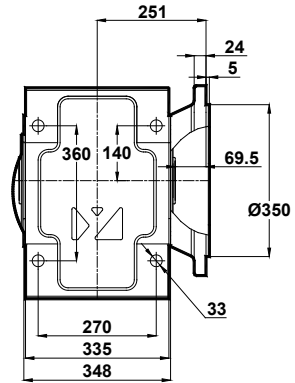
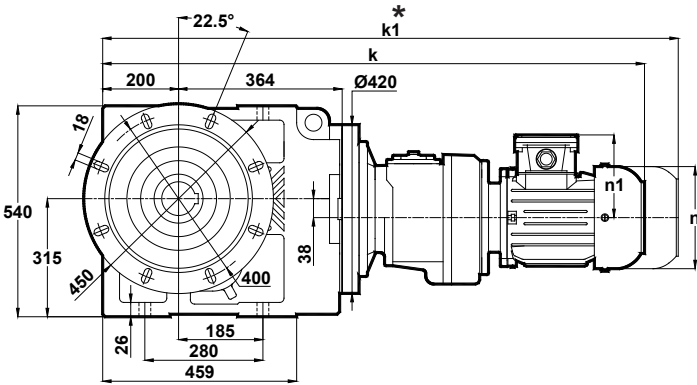

	71	80	90S	90L	100L
k	1010	1038	1067	1092	1132
k1	1130	1158	1192	1217	1267
n	138	156	176	176	194
n1	110	118	126	126	135

\* " k1 " Ölçüsü frenli redüktörlere aittir.  
Dimension " k1 " is for motors with brake.  
Maße " k1 " ist für Bremsenmotoren.

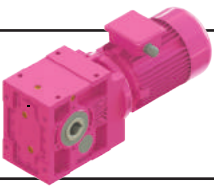

# Ölçü Sayfaları Dimension Pages Abmessungsseiten

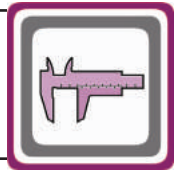

-Mil ucu çektirme deliği DIN 332 sayfa 2 / Tapped center hole to DIN 332, sheet 2 / Zentrierung mit gewinde DIN 332, Blatt 2

KR775.04  
KR776.04

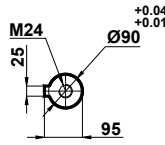
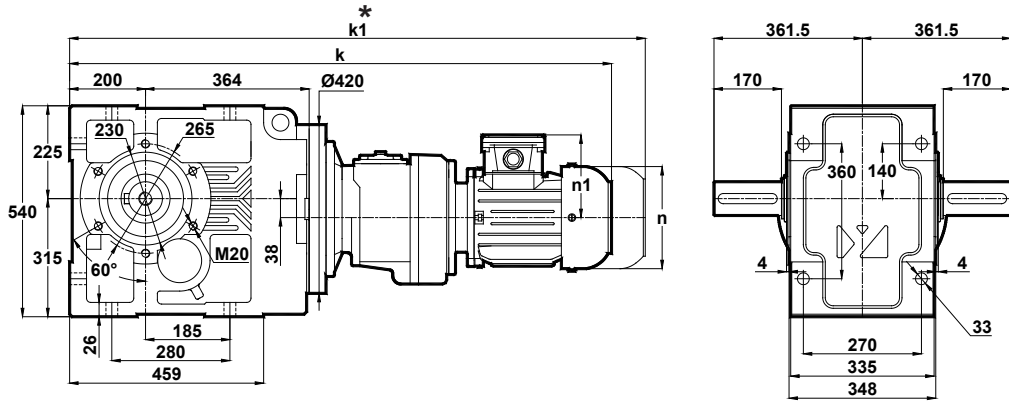

Klemens Pozisyonları  
Terminal Box Positions  
Klemmenkasten Positionen

	71	80	90S	90L	100L
k	1010	1038	1067	1092	1132
k1	1130	1158	1192	1217	1267
n	138	156	176	176	194
n1	110	118	126	126	135

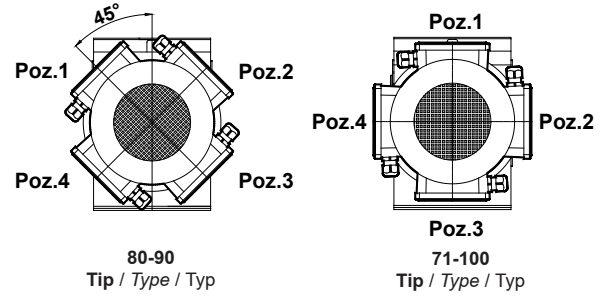

KR775.05  
KR776.05

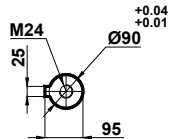
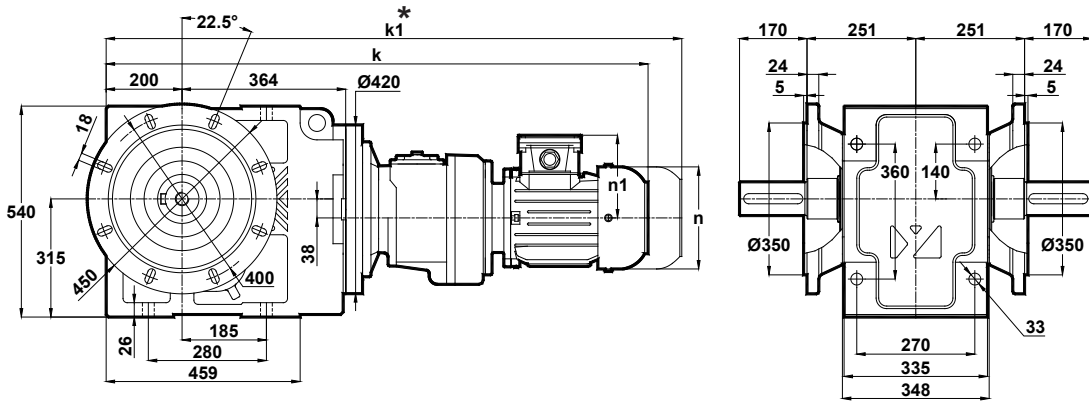

	71	80	90S	90L	100L
k	1010	1038	1067	1092	1132
k1	1130	1158	1192	1217	1267
n	138	156	176	176	194
n1	110	118	126	126	135

\* "k1" Ölçüsü frenli redüktörlere aittir.  
Dimension "k1" is for motors with brake.  
Maße "k1" ist für Bremsenmotoren.

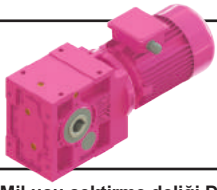

# Ölçü Sayfaları Dimension Pages Abmessungsseiten

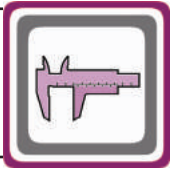

-Mil ucu çektirme deliği DIN 332 sayfa 2 / Tapped center hole to DIN 332, sheet 2 / Zentrierung mit gewinde DIN 332, Blatt 2

KR775.08  
KR776.08

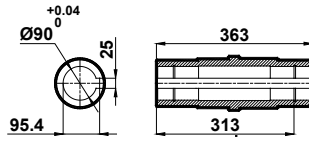
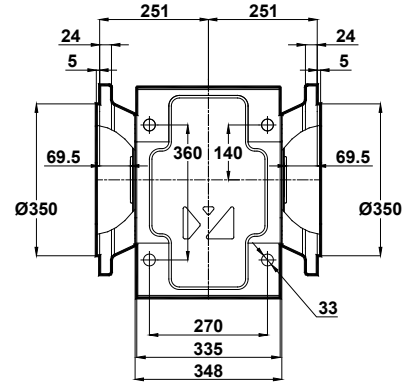
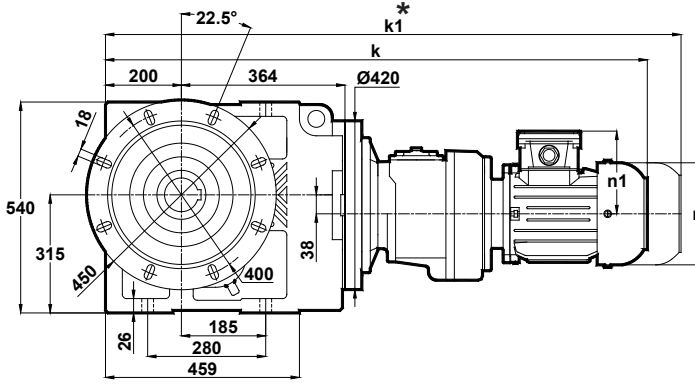

Klemens Pozisyonları  
Terminal Box Positions  
Klemmenkasten Positionen

	71	80	90S	90L	100L
k	1010	1038	1067	1092	1132
k1	1130	1158	1192	1217	1267
n	138	156	176	176	194
n1	110	118	126	126	135

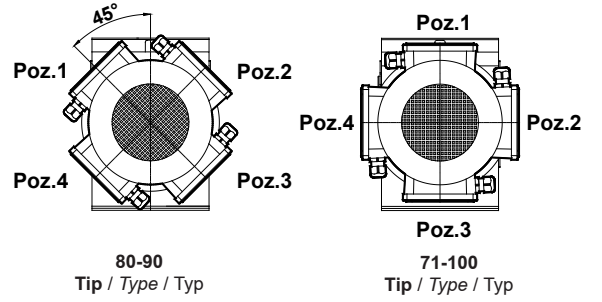

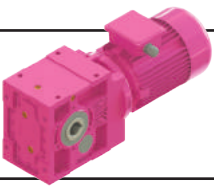

# Ölçü Sayfaları Dimension Pages Abmessungsseiten

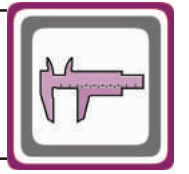

-Mil ucu çektirme deliği DIN 332 sayfa 2 / Tapped center hole to DIN 332, sheet 2 / Zentrierung mit gewinde DIN 332, Blatt 2

## KR873.00

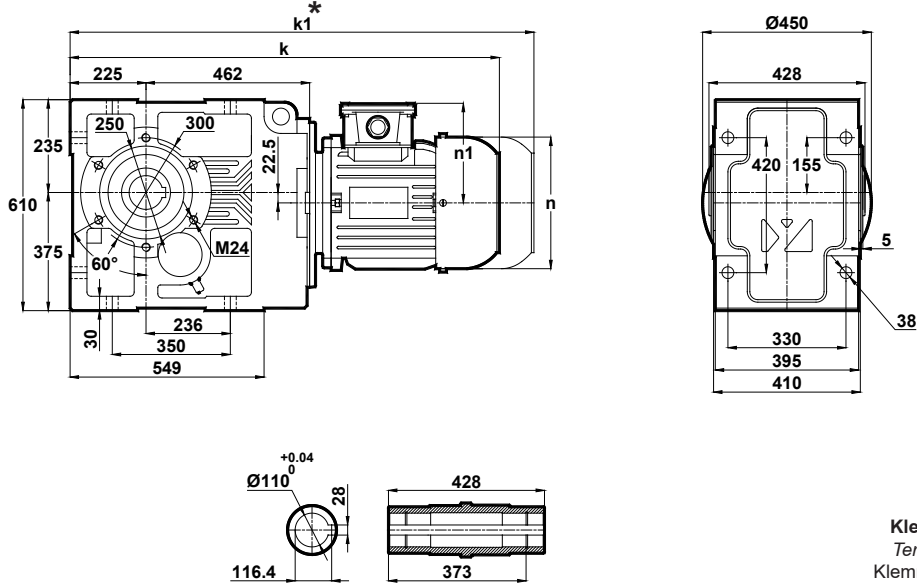

Klemens Pozisyonları  
Terminal Box Positions  
Klemmenkasten Positionen

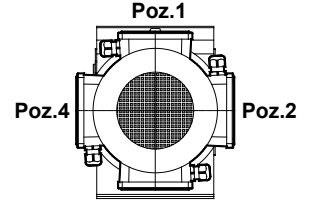

Poz.1  
132-160-180-200-225-250-280  
Tip / Type / Typ

	132M	160M	160L	180M	180L	200L	225S	225M	250M	280S	280M
k	1088	1156	1200	1216	1254	1293	1309	1334	1437	1498	1498
k1	1233	1326	1370	1386	1424	1493	-	-	-	-	-
n	258	310	310	348	348	390	433	433	480	544	544
n1	168	225	225	241	241	275	285	285	322	350	350

## KR873.01

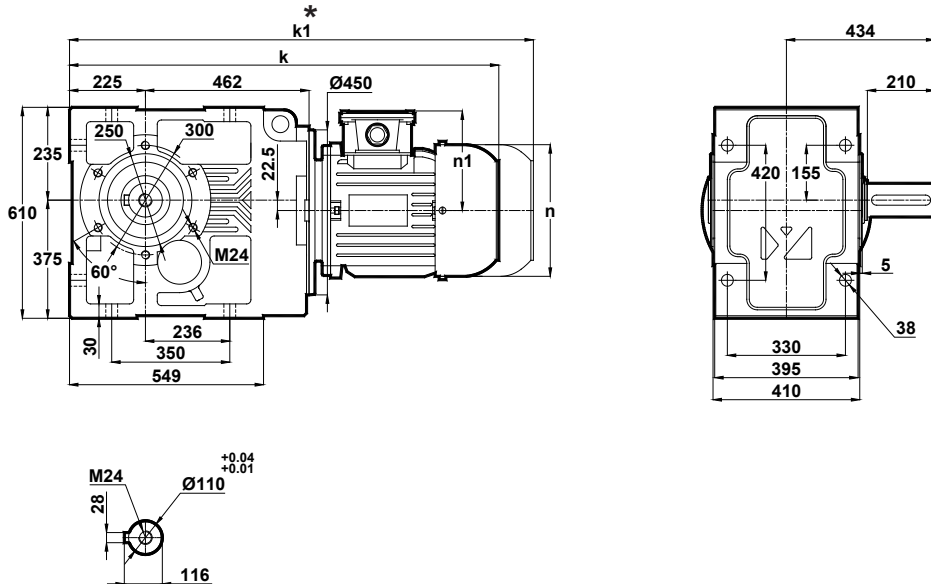

	132M	160M	160L	180M	180L	200L	225S	225M	250M	280S	280M
k	1088	1156	1200	1216	1254	1293	1309	1334	1437	1498	1498
k1	1233	1326	1370	1386	1424	1493	-	-	-	-	-
n	258	310	310	348	348	390	433	433	480	544	544
n1	168	225	225	241	241	275	285	285	322	350	350

\* "k1" Ölçüsü frenli redüktörlere aittir.  
Dimension "k1" is for motors with brake.  
Maße "k1" ist für Bremsenmotoren.

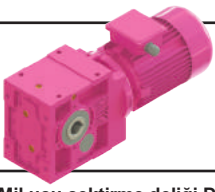

# Ölçü Sayfaları

## Dimension Pages

### Abmessungsseiten

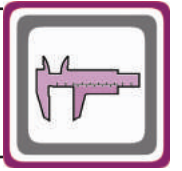

-Mil ucu çektirme deliği DIN 332 sayfa 2 / Tapped center hole to DIN 332, sheet 2 / Zentrierung mit gewinde DIN 332, Blatt 2

#### KR873.02

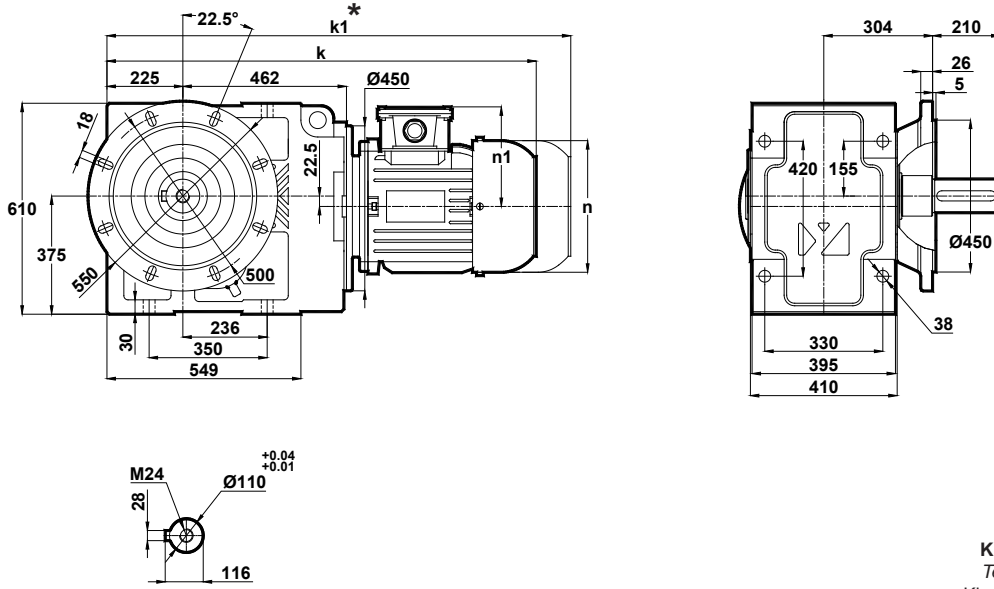

Klemens Pozisyonları  
Terminal Box Positions  
Klemmenkasten Positionen

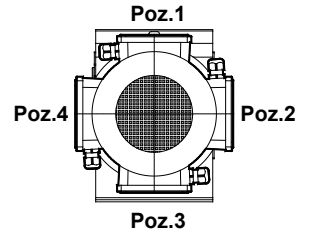

132-160-180-200-225-250-280  
Tip / Type / Typ

	132M	160M	160L	180M	180L	200L	225S	225M	250M	280S	280M
k	1088	1156	1200	1216	1254	1293	1309	1334	1437	1498	1498
k1	1233	1326	1370	1386	1424	1493	-	-	-	-	-
n	258	310	310	348	348	390	433	433	480	544	544
n1	168	225	225	241	241	275	285	285	322	350	350

#### KR873.03

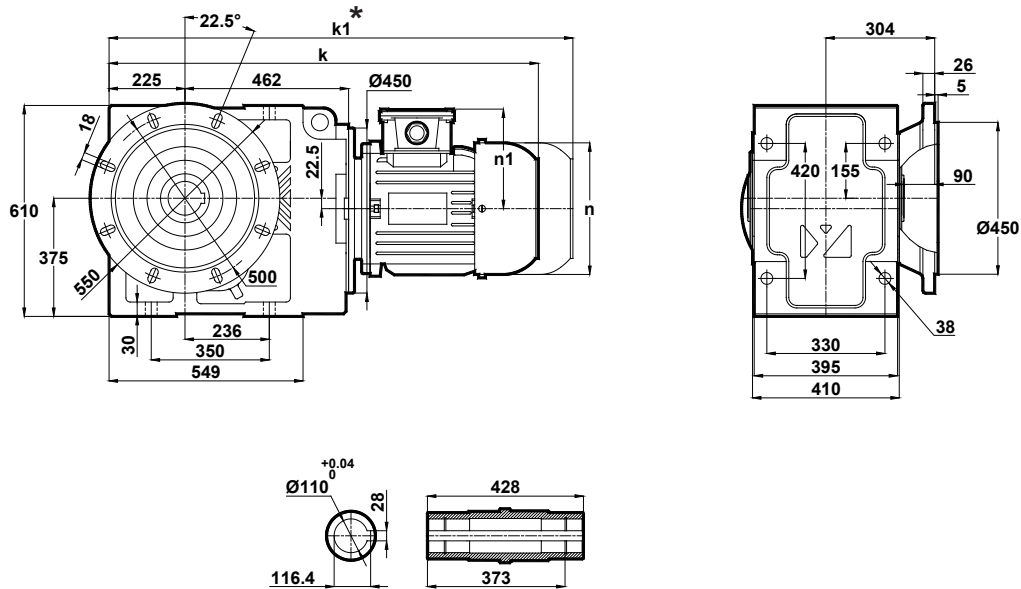

	132M	160M	160L	180M	180L	200L	225S	225M	250M	280S	280M
k	1088	1156	1200	1216	1254	1293	1309	1334	1437	1498	1498
k1	1233	1326	1370	1386	1424	1493	-	-	-	-	-
n	258	310	310	348	348	390	433	433	480	544	544
n1	168	225	225	241	241	275	285	285	322	350	350

\* " k1 " Ölçüsü frenli redüktörlere aittir.  
Dimension " k1 " is for motors with brake.  
Maße " k1 " ist für Bremsenmotoren.

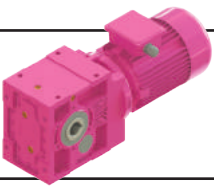

# Ölçü Sayfaları Dimension Pages Abmessungsseiten

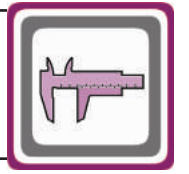

-Mil ucu çektirme deliği DIN 332 sayfa 2 / Tapped center hole to DIN 332, sheet 2 / Zentrierung mit gewinde DIN 332, Blatt 2

## KR873.04

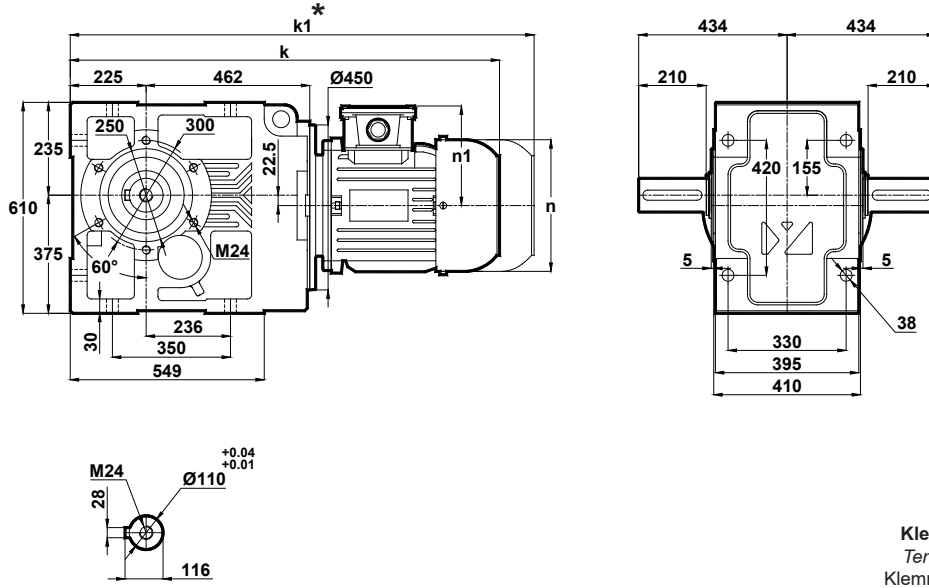

Klemens Pozisyonları  
Terminal Box Positions  
Klemmenkasten Positionen

	132M	160M	160L	180M	180L	200L	225S	225M	250M	280S	280M
k	1088	1156	1200	1216	1254	1293	1309	1334	1437	1498	1498
k1	1233	1326	1370	1386	1424	1493	-	-	-	-	-
n	258	310	310	348	348	390	433	433	480	544	544
n1	168	225	225	241	241	275	285	285	322	350	350

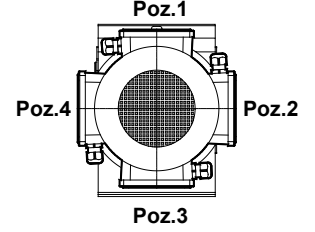

132-160-180-200-225-250-280  
Tip / Type / Typ

## KR873.05

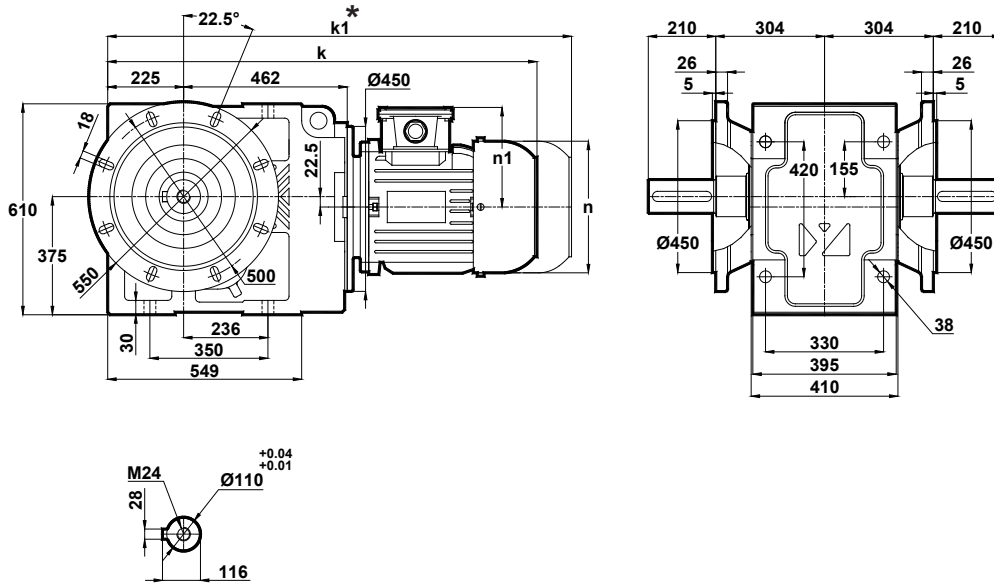

	132M	160M	160L	180M	180L	200L	225S	225M	250M	280S	280M
k	1088	1156	1200	1216	1254	1293	1309	1334	1437	1498	1498
k1	1233	1326	1370	1386	1424	1493	-	-	-	-	-
n	258	310	310	348	348	390	433	433	480	544	544
n1	168	225	225	241	241	275	285	285	322	350	350

\* "k1" Ölçüsü frenli redüktörlere aittir.  
Dimension "k1" is for motors with brake.  
Maße "k1" ist für Bremsenmotoren.

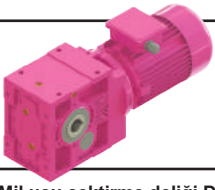

# Ölçü Sayfaları Dimension Pages Abmessungsseiten

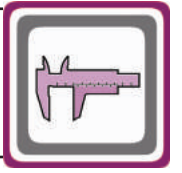

-Mil ucu çektirme deliği DIN 332 sayfa 2 / Tapped center hole to DIN 332, sheet 2 / Zentrierung mit gewinde DIN 332, Blatt 2

KR873.08

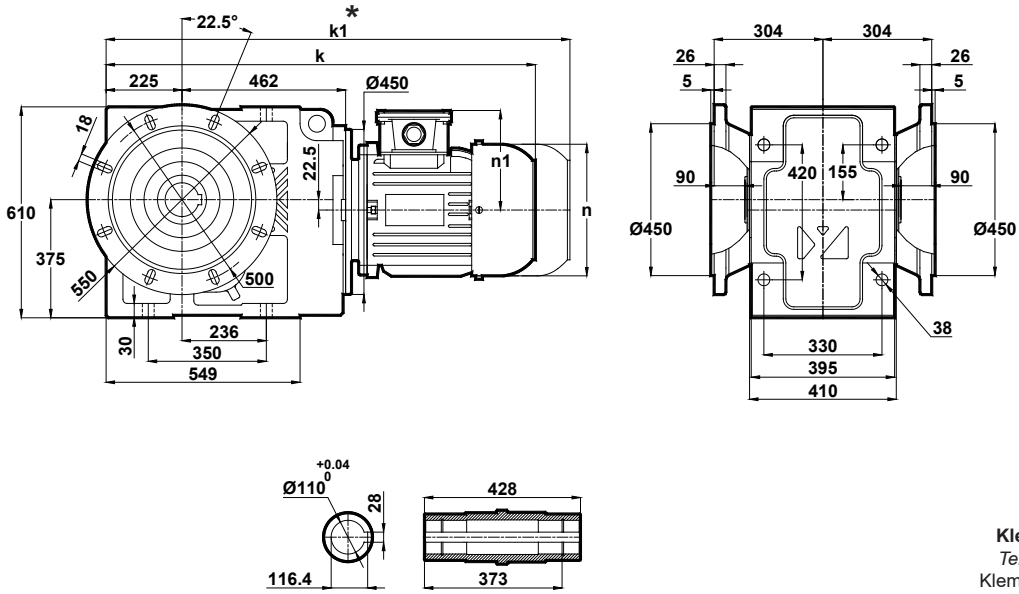

Klemens Pozisyonları  
Terminal Box Positions  
Klemmenkasten Positionen

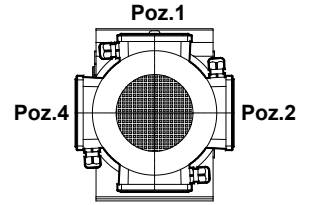

Poz.1  
Poz.2  
Poz.3  
Poz.4  
132-160-180-200-225-250-280  
Tip / Type / Typ

	132M	160M	160L	180M	180L	200L	225S	225M	250M	280S	280M
k	1088	1156	1200	1216	1254	1293	1309	1334	1437	1498	1498
k1	1233	1326	1370	1386	1424	1493	-	-	-	-	-
n	258	310	310	348	348	390	433	433	480	544	544
n1	168	225	225	241	241	275	285	285	322	350	350

\* " k1 " Ölçüsü frenli redüktörlere aittir.  
Dimension " k1 " is for motors with brake.  
Maße " k1 " ist für Bremsenmotoren.

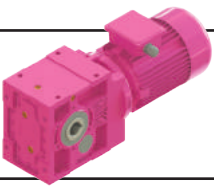

# Ölçü Sayfaları Dimension Pages Abmessungsseiten

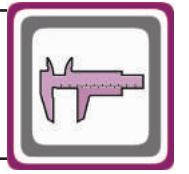

-Mil ucu çekirme deliği DIN 332 sayfa 2 / Tapped center hole to DIN 332, sheet 2 / Zentrierung mit gewinde DIN 332, Blatt 2

## KR874.00

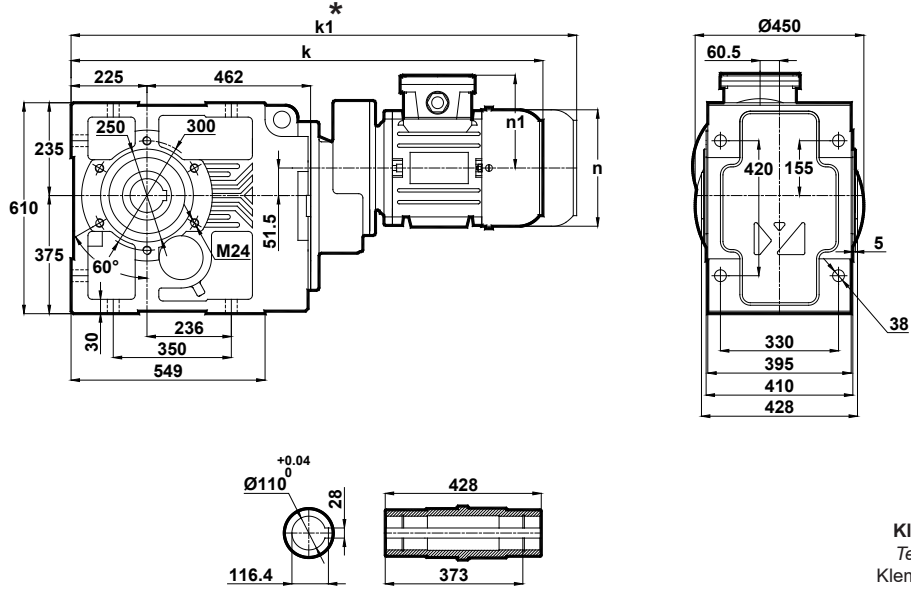

	100L	112M	132S	132M	160M	160L	180M
k	1115.5	1138.5	1192.5	1230.5	1305.5	1349.5	1366
k1	1250.5	1273.5	1337.5	1375.5	1475.5	1519.5	1536
n	194	218	258	258	310	310	348
n1	135	146	168	168	225	225	241

Klemens Pozisyonları  
Terminal Box Positions  
Klemmenkasten Positionen

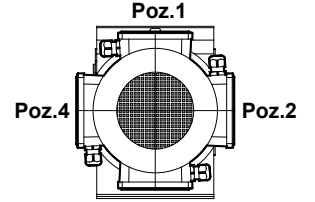

Poz.1  
100-112-132-160-180  
Tip / Type / Typ

## KR874.01

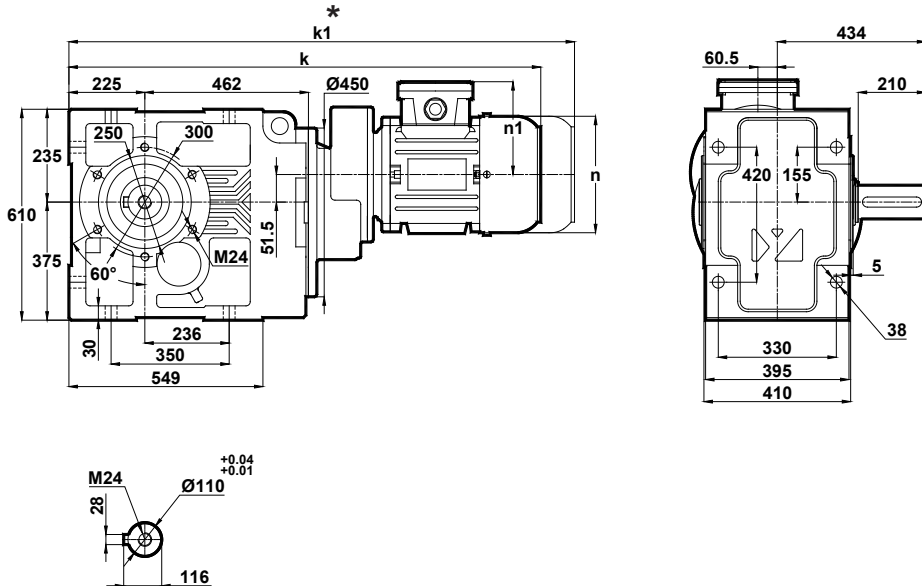

	100L	112M	132S	132M	160M	160L	180M
k	1115.5	1138.5	1192.5	1230.5	1305.5	1349.5	1366
k1	1250.5	1273.5	1337.5	1375.5	1475.5	1519.5	1536
n	194	218	258	258	310	310	348
n1	135	146	168	168	225	225	241

\* "k1" Ölçüsü frenli redüktörlere aittir.  
Dimension "k1" is for motors with brake.  
Maße "k1" ist für Bremsenmotoren.

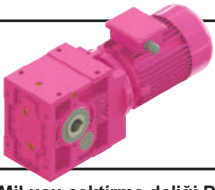

# Ölçü Sayfaları Dimension Pages Abmessungsseiten

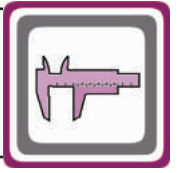

-Mil ucu çektirme deliği DIN 332 sayfa 2 / Tapped center hole to DIN 332, sheet 2 / Zentrierung mit gewinde DIN 332, Blatt 2

## KR874.02

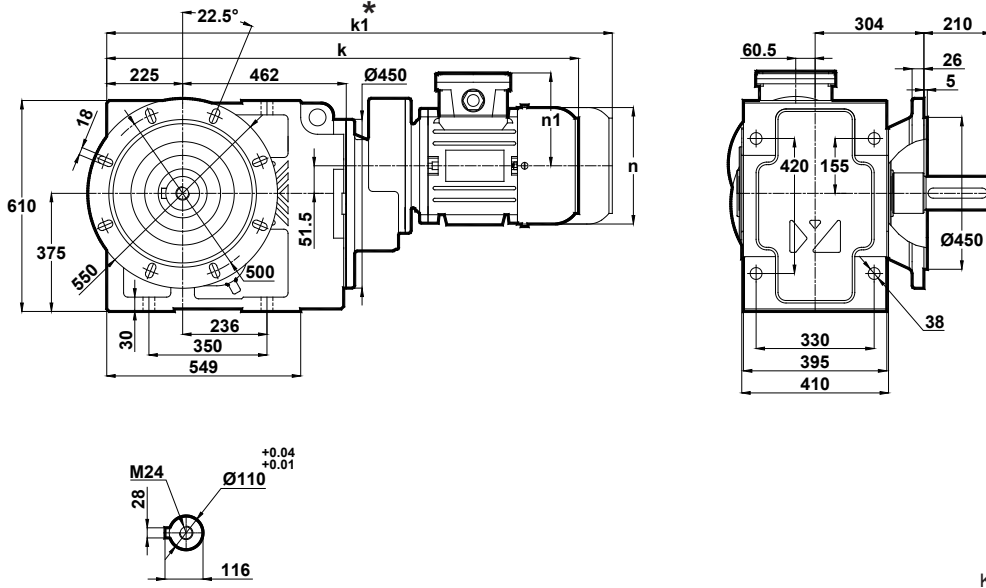

	100L	112M	132S	132M	160M	160L	180M
k	1115.5	1138.5	1192.5	1230.5	1305.5	1349.5	1366
k1	1250.5	1273.5	1337.5	1375.5	1475.5	1519.5	1536
n	194	218	258	258	310	310	348
n1	135	146	168	168	225	225	241

Klemens Pozisyonları  
Terminal Box Positions  
Klemmenkasten Positionen

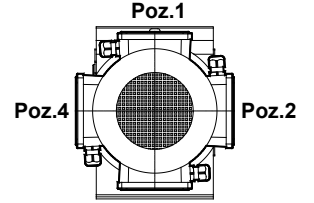

Poz.3

100-112-132-160-180  
Tip / Type / Typ

## KR874.03

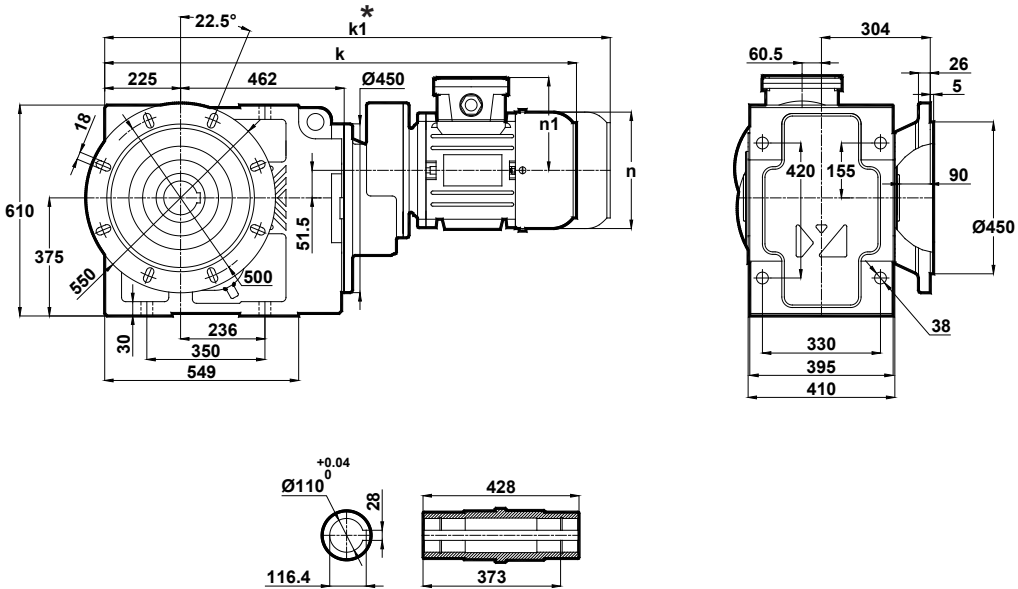

	100L	112M	132S	132M	160M	160L	180M
k	1115.5	1138.5	1192.5	1230.5	1305.5	1349.5	1366
k1	1250.5	1273.5	1337.5	1375.5	1475.5	1519.5	1536
n	194	218	258	258	310	310	348
n1	135	146	168	168	225	225	241

\* "k1" Ölçüsü frenli redüktörlere aittir.  
Dimension "k1" is for motors with brake.  
Maße "k1" ist für Bremsenmotoren.

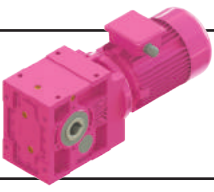

# Ölçü Sayfaları

## Dimension Pages

### Abmessungsseiten

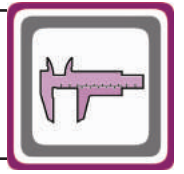

-Mil ucu çekirme deliği DIN 332 sayfa 2 / Tapped center hole to DIN 332, sheet 2 / Zentrierung mit gewinde DIN 332, Blatt 2

#### KR874.04

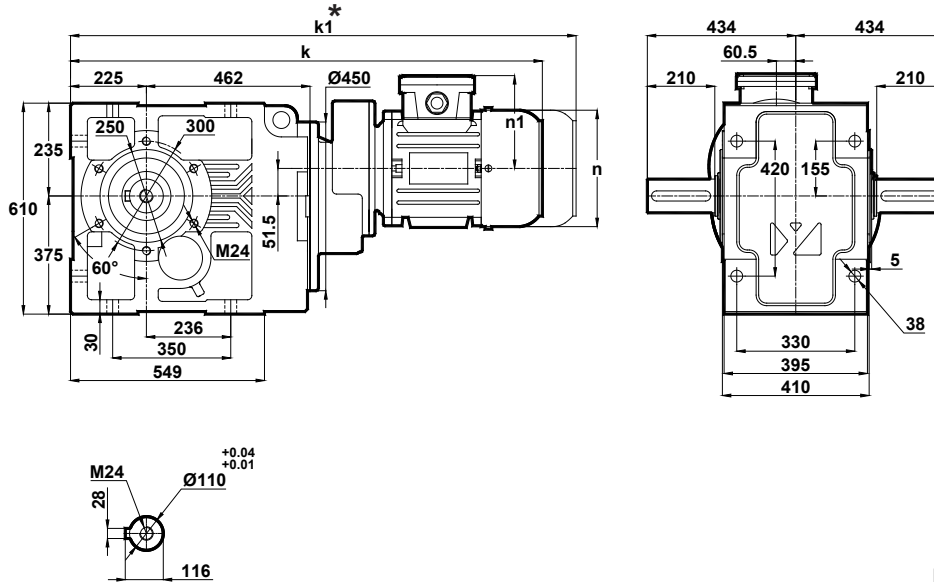

	100L	112M	132S	132M	160M	160L	180M
k	1115.5	1138.5	1192.5	1230.5	1305.5	1349.5	1366
k1	1250.5	1273.5	1337.5	1375.5	1475.5	1519.5	1536
n	194	218	258	258	310	310	348
n1	135	146	168	168	225	225	241

Klemens Pozisyonları  
Terminal Box Positions  
Klemmenkasten Positionen

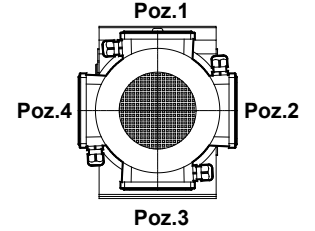

100-112-132-160-180  
Tip / Type / Typ

#### KR874.05

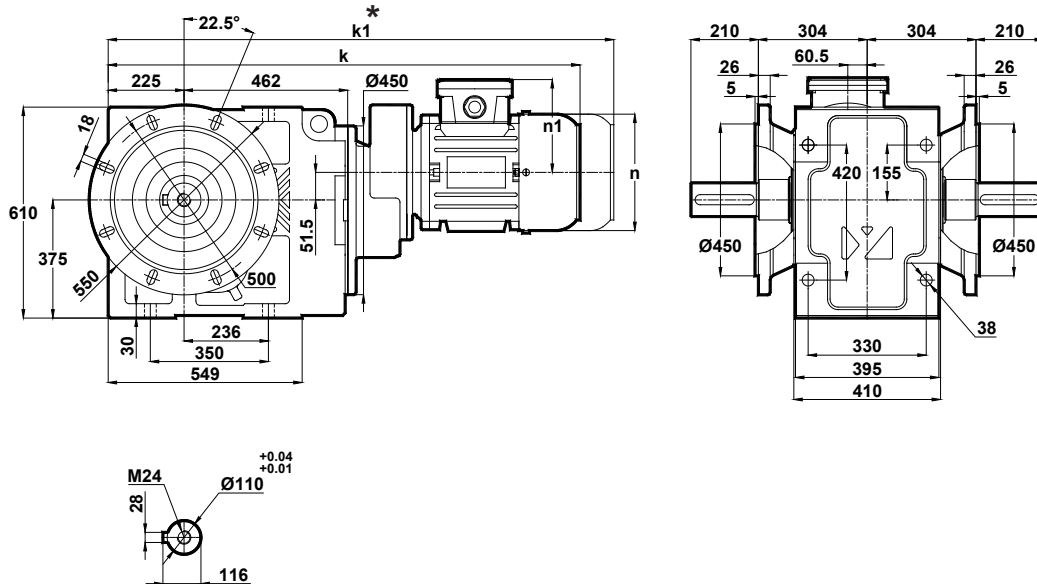

	100L	112M	132S	132M	160M	160L	180M
k	1115.5	1138.5	1192.5	1230.5	1305.5	1349.5	1366
k1	1250.5	1273.5	1337.5	1375.5	1475.5	1519.5	1536
n	194	218	258	258	310	310	348
n1	135	146	168	168	225	225	241

\* "k1" Ölçüsü frenli redüktörlere aittir.  
Dimension "k1" is for motors with brake.  
Maße "k1" ist für Bremsmotoren.

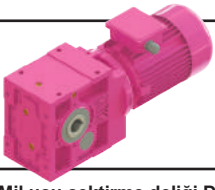

# Ölçü Sayfaları Dimension Pages Abmessungsseiten

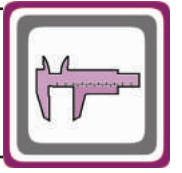

-Mil ucu çektirme deliği DIN 332 sayfa 2 / Tapped center hole to DIN 332, sheet 2 / Zentrierung mit gewinde DIN 332, Blatt 2

KR874.08

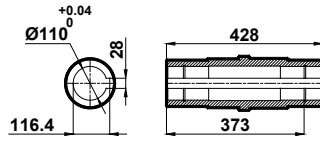
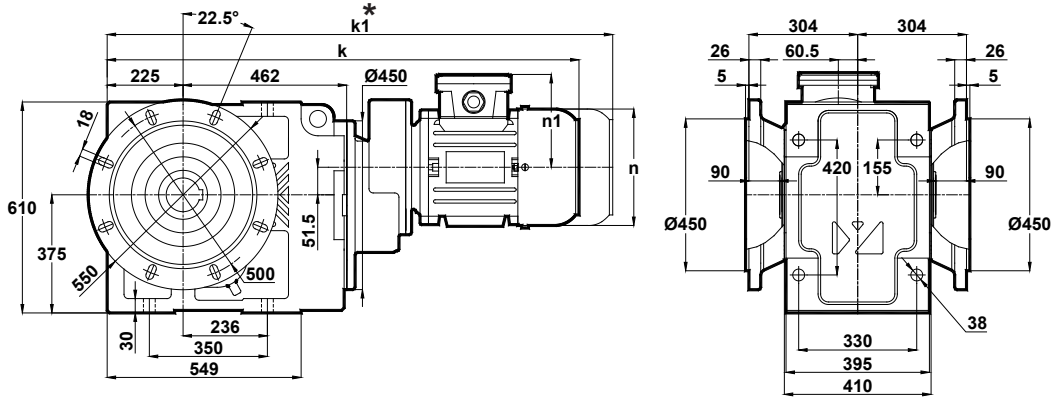

Klemens Pozisyonları  
Terminal Box Positions  
Klemmenkasten Positionen

	100L	112M	132S	132M	160M	160L	180M
k	1115.5	1138.5	1192.5	1230.5	1305.5	1349.5	1366
k1	1250.5	1273.5	1337.5	1375.5	1475.5	1519.5	1536
n	194	218	258	258	310	310	348
n1	135	146	168	168	225	225	241

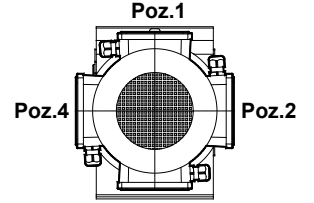

Poz.1  
Poz.2  
Poz.3  
Poz.4  
100-112-132-160-180  
Tip / Type / Typ

\* " k1 " Ölçüsü frenli redüktörlere aittir.  
Dimension " k1 " is for motors with brake.  
Maße " k1 " ist für Bremsenmotoren.

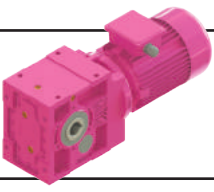

# Ölçü Sayfaları Dimension Pages Abmessungsseiten

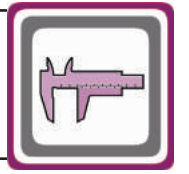

-Mil ucu çektirme deliği DIN 332 sayfa 2 / Tapped center hole to DIN 332, sheet 2 / Zentrierung mit gewinde DIN 332, Blatt 2

KR875.00  
KR876.00

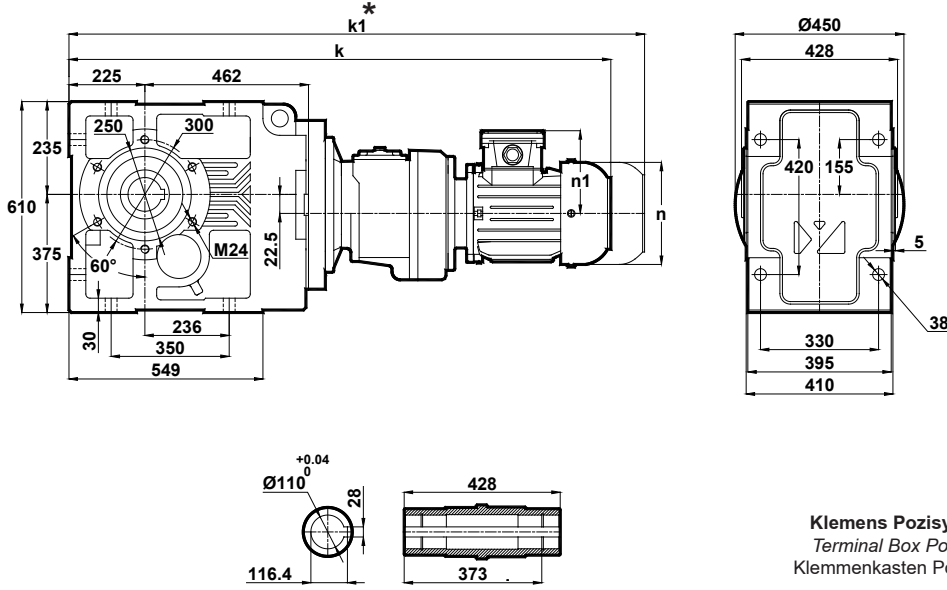

Klemens Pozisyonları  
Terminal Box Positions  
Klemmenkasten Positionen

	71	80	90S	90L	100L	112M
k	1133	1161	1190	1215	1255	1278
k1	1253	1281	1315	1340	1390	1413
n	138	156	176	176	194	218
n1	110	118	126	126	135	146

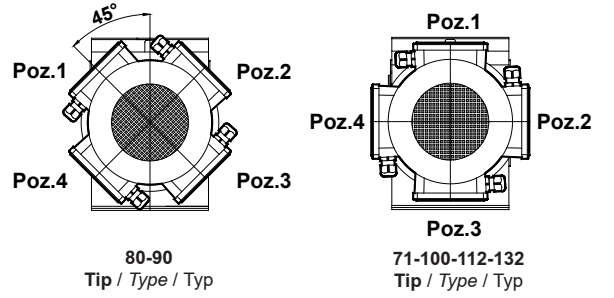

KR875.01  
KR876.01

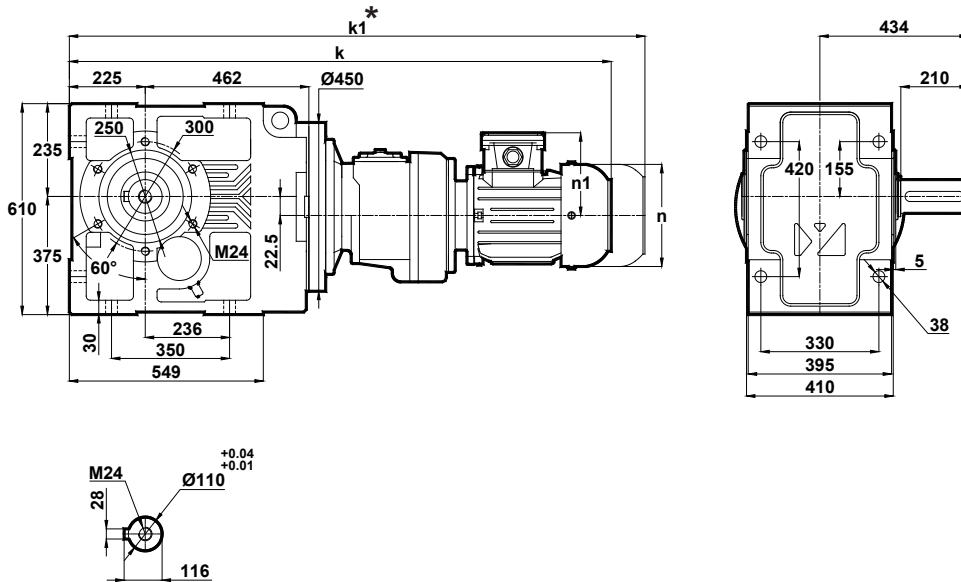

	71	80	90S	90L	100L	112M
k	1133	1161	1190	1215	1255	1278
k1	1253	1281	1315	1340	1390	1413
n	138	156	176	176	194	218
n1	110	118	126	126	135	146

\* "k1" Ölçüsü frenli redüktörlere aittir.  
Dimension "k1" is for motors with brake.  
Maße "k1" ist für Bremsenmotoren.

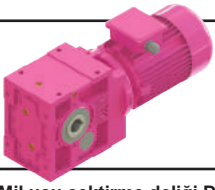

# Ölçü Sayfaları Dimension Pages Abmessungenseiten

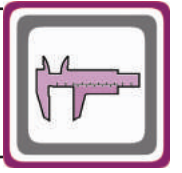

-Mil ucu çektirme deliği DIN 332 sayfa 2 / Tapped center hole to DIN 332, sheet 2 / Zentrierung mit gewinde DIN 332, Blatt 2

KR875.02  
KR876.02

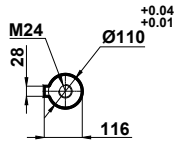
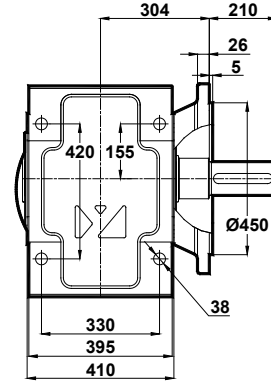
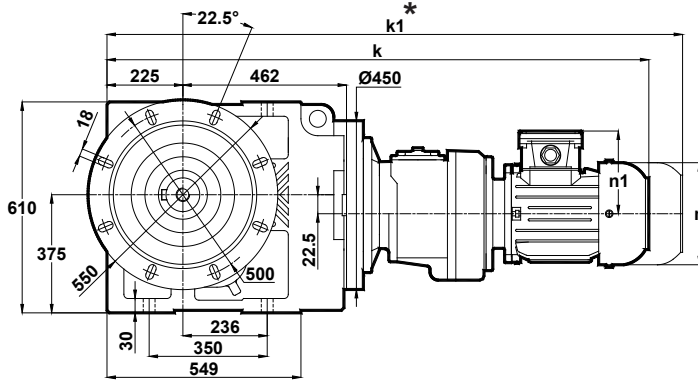

Klemens Pozisyonları  
Terminal Box Positions  
Klemmenkasten Positionen

	71	80	90S	90L	100L	112M
k	1133	1161	1190	1215	1255	1278
k1	1253	1281	1315	1340	1390	1413
n	138	156	176	176	194	218
n1	110	118	126	126	135	146

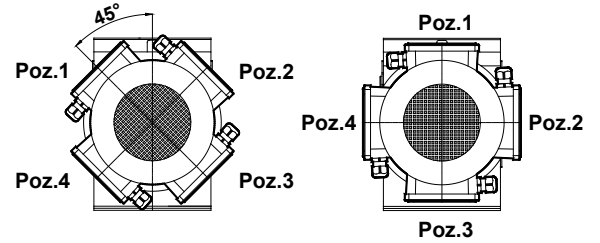

80-90  
Tip / Type / Typ

71-100-112-132  
Tip / Type / Typ

KR875.03  
KR876.03

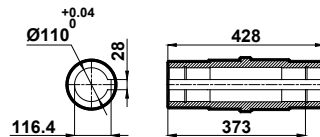
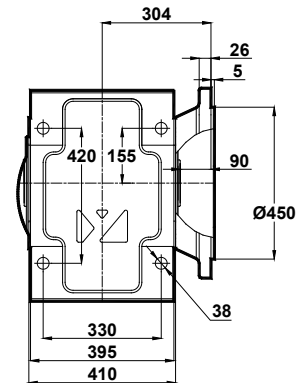
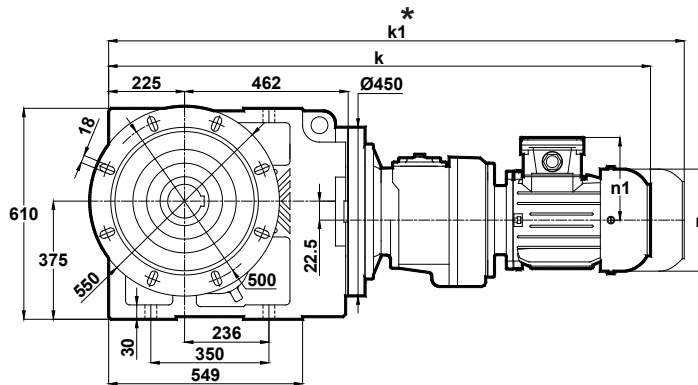

	71	80	90S	90L	100L	112M
k	1133	1161	1190	1215	1255	1278
k1	1253	1281	1315	1340	1390	1413
n	138	156	176	176	194	218
n1	110	118	126	126	135	146

\* " k1 " Ölçüsü frenli redüktörlere aittir.  
Dimension " k1 " is for motors with brake.  
Maße " k1 " ist für Bremsenmotoren.

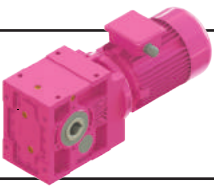

# Ölçü Sayfaları Dimension Pages Abmessungsseiten

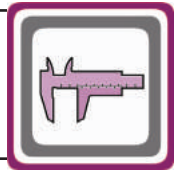

-Mil ucu çektirme deliği DIN 332 sayfa 2 / Tapped center hole to DIN 332, sheet 2 / Zentrierung mit gewinde DIN 332, Blatt 2

KR875.04  
KR876.04

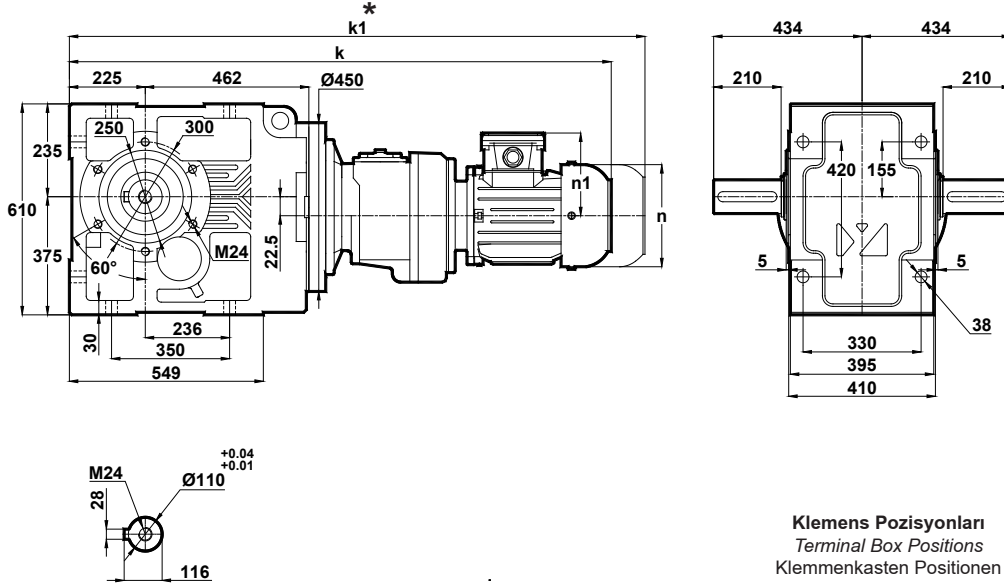

	71	80	90S	90L	100L	112M
k	1133	1161	1190	1215	1255	1278
k1	1253	1281	1315	1340	1390	1413
n	138	156	176	176	194	218
n1	110	118	126	126	135	146

Klemens Pozisyonları  
Terminal Box Positions  
Klemmenkasten Positionen

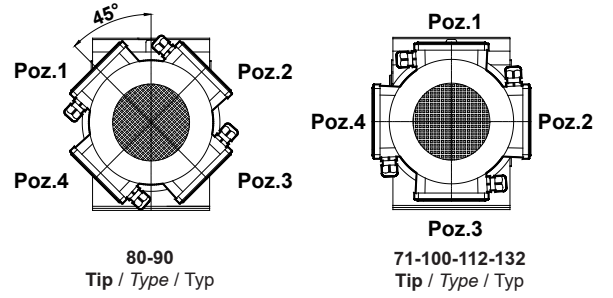

KR875.05  
KR876.05

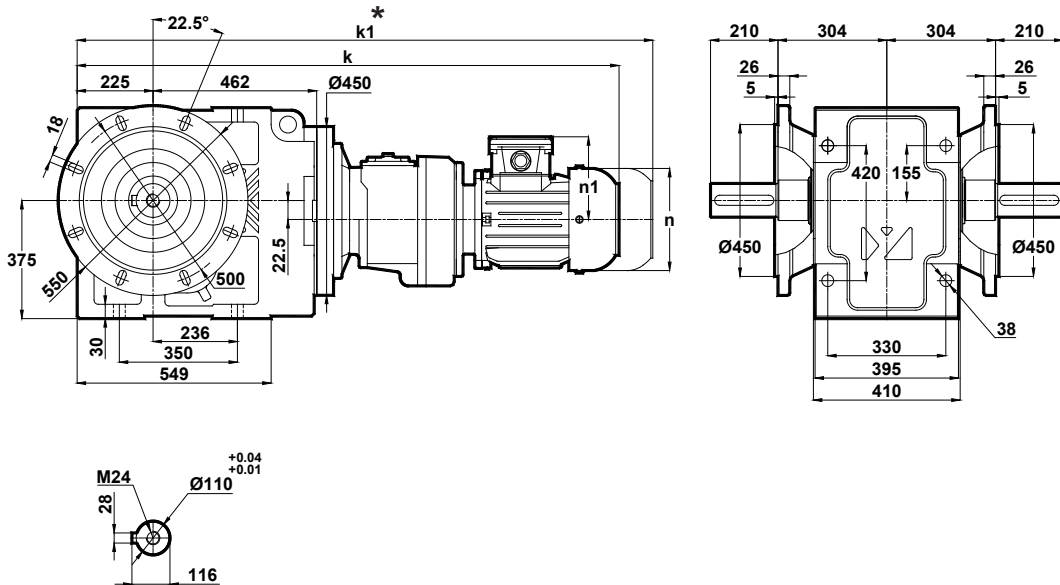

	71	80	90S	90L	100L	112M
k	1133	1161	1190	1215	1255	1278
k1	1253	1281	1315	1340	1390	1413
n	138	156	176	176	194	218
n1	110	118	126	126	135	146

\* "k1" Ölçüsü frenli redüktörlere aittir.  
Dimension "k1" is for motors with brake.  
Maße "k1" ist für Bremsenmotoren.

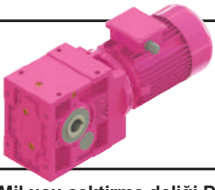

# Ölçü Sayfaları Dimension Pages Abmessungsseiten

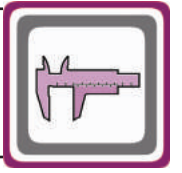

-Mil ucu çektirme deliği DIN 332 sayfa 2 / Tapped center hole to DIN 332, sheet 2 / Zentrierung mit gewinde DIN 332, Blatt 2

KR875.08  
KR876.08

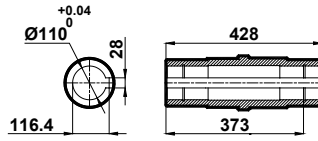
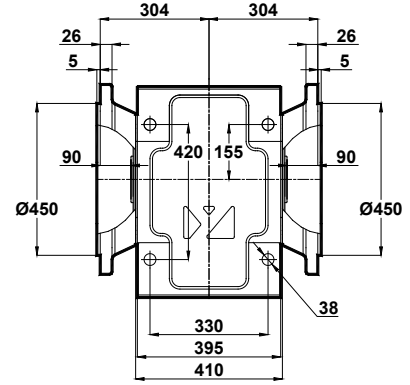
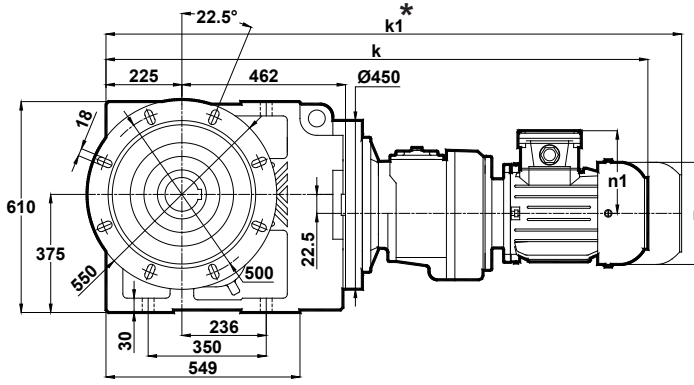

Klemens Pozisyonları  
Terminal Box Positions  
Klemmenkasten Positionen

	71	80	90S	90L	100L	112M
k	1133	1161	1190	1215	1255	1278
k1	1253	1281	1315	1340	1390	1413
n	138	156	176	176	194	218
n1	110	118	126	126	135	146

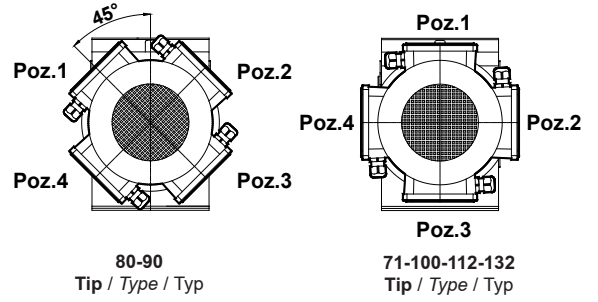

80-90  
Tip / Type / Typ

71-100-112-132  
Tip / Type / Typ

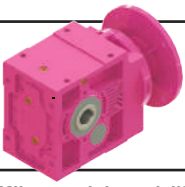

# Ölçü Sayfaları Dimension Pages Abmessungsseiten

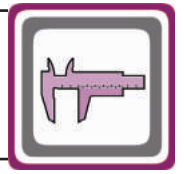

-Mil ucu çekirme deliği DIN 332 sayfa 2 / Tapped center hole to DIN 332, sheet 2 / Zentrierung mit gewinde DIN 332, Blatt 2

KN002.00  
KN003.00

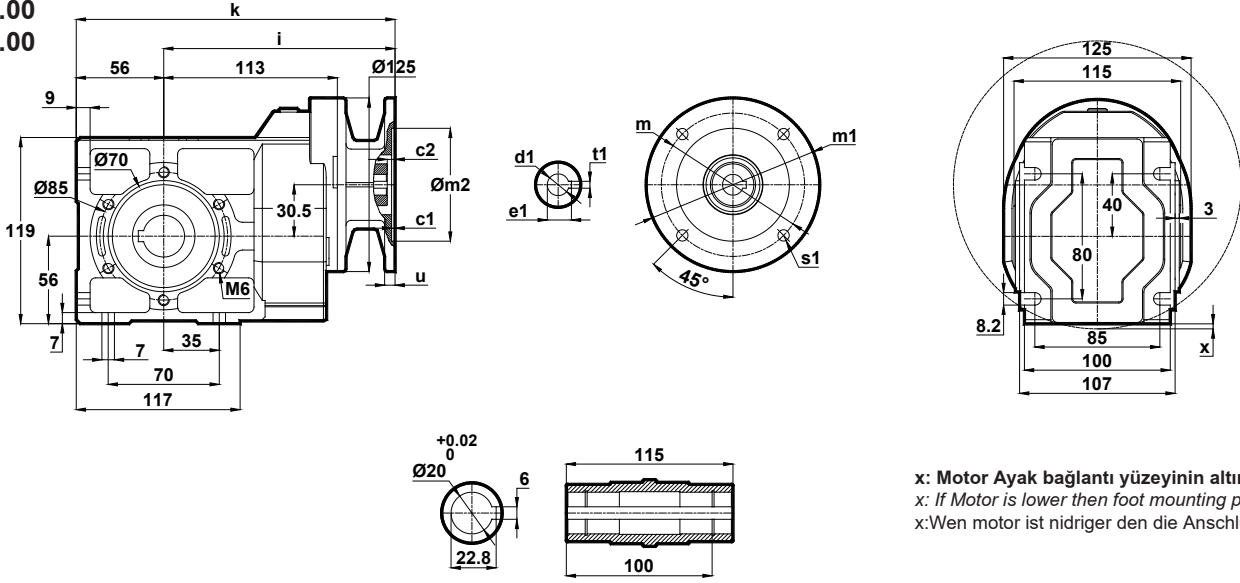

x: Motor Ayak bağlantı yüzeyinin altında ise  
x: If Motor is lower then foot mounting plane  
x: Wenn motor ist niedriger den die Anschlußplatte

	c1	c2	s1	m	m1	m2	i	u	k	d1	t1	e1	x
63/B5	3.5	5	10	115	140	95	156	10	212	11	4	12.8	-
71/B5	4	4.5	11	130	160	110	157.5	12	213.5	14	5	16.3	-
80/B5	4	5	13	165	200	130	172.5	12	228.5	19	6	21.8	13.5
90/B5	4	5	13	165	200	130	172.5	12	228.5	24	8	27.3	13.5

KN002.01  
KN003.01

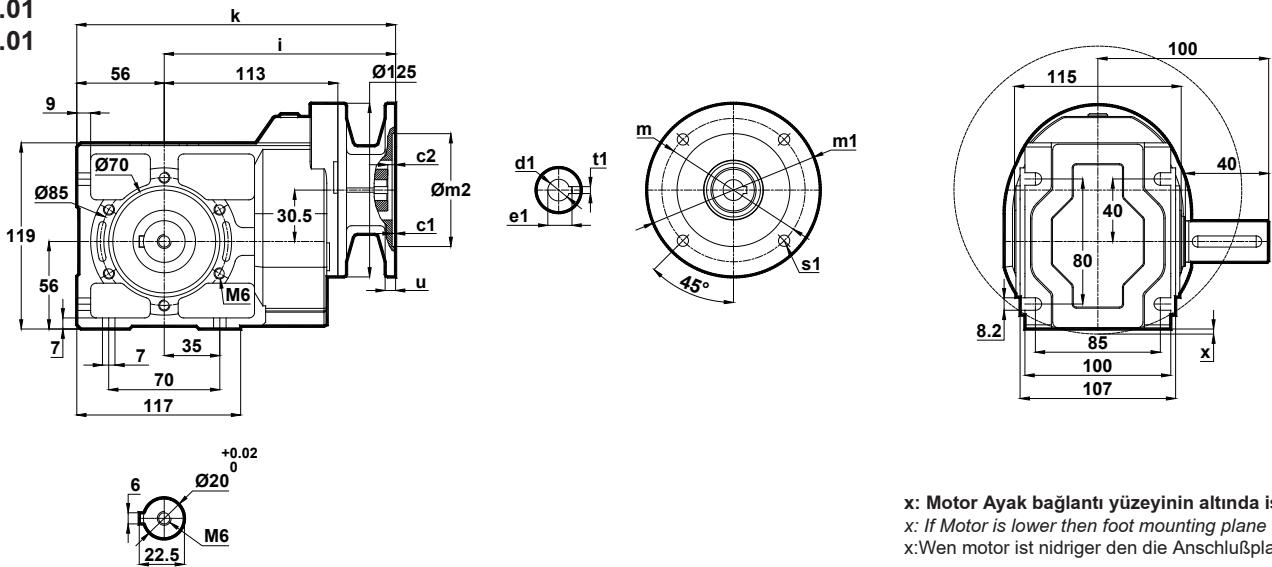

x: Motor Ayak bağlantı yüzeyinin altında ise  
x: If Motor is lower then foot mounting plane  
x: Wenn motor ist niedriger den die Anschlußplatte

	c1	c2	s1	m	m1	m2	i	u	k	d1	t1	e1	x
63/B5	3.5	5	10	115	140	95	156	10	212	11	4	12.8	-
71/B5	4	4.5	11	130	160	110	157.5	12	213.5	14	5	16.3	-
80/B5	4	5	13	165	200	130	172.5	12	228.5	19	6	21.8	13.5
90/B5	4	5	13	165	200	130	172.5	12	228.5	24	8	27.3	13.5

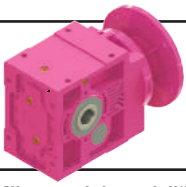

# Ölçü Sayfaları Dimension Pages Abmessungsseiten

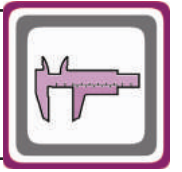

-Mil ucu çekirme deliği DIN 332 sayfa 2 / Tapped center hole to DIN 332, sheet 2 / Zentrierung mit gewinde DIN 332, Blatt 2

KN002.02  
KN003.02

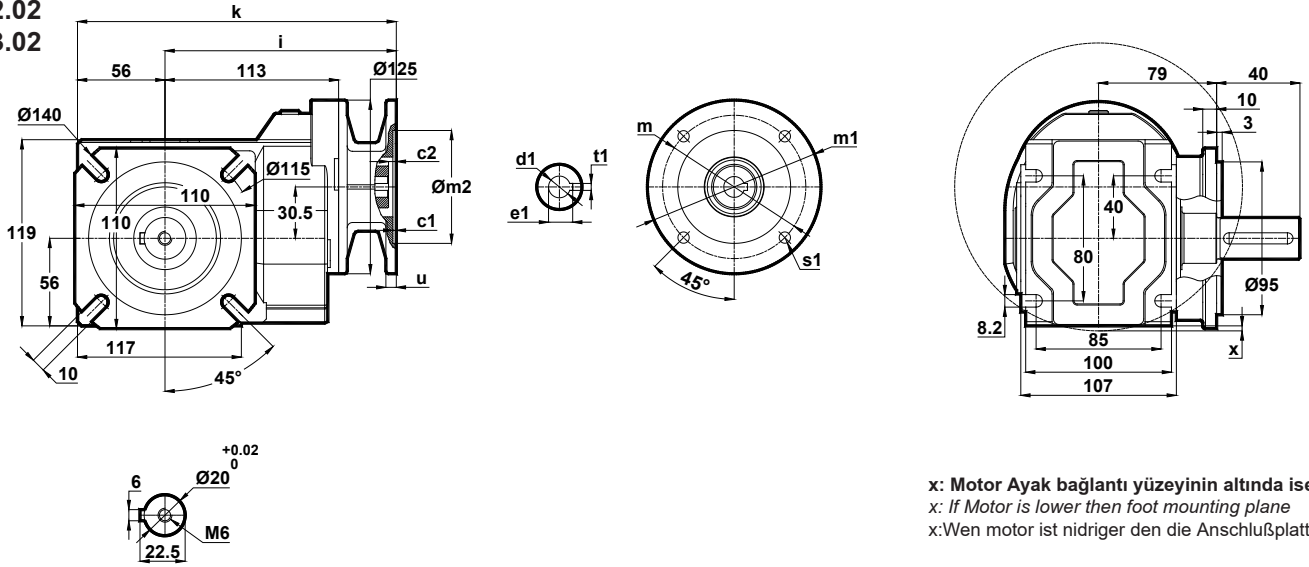

x: Motor Ayak bağlantı yüzeyinin altında ise  
x: If Motor is lower then foot mounting plane  
x:Wen motor ist nidriger den die Anschlußplatte

	c1	c2	s1	m	m1	m2	i	u	k	d1	t1	e1	x
63/B5	3.5	5	10	115	140	95	156	10	212	11	4	12.8	-
71/B5	4	4.5	11	130	160	110	157.5	12	213.5	14	5	16.3	-
80/B5	4	5	13	165	200	130	172.5	12	228.5	19	6	21.8	13.5
90/B5	4	5	13	165	200	130	172.5	12	228.5	24	8	27.3	13.5

KN002.03  
KN003.03

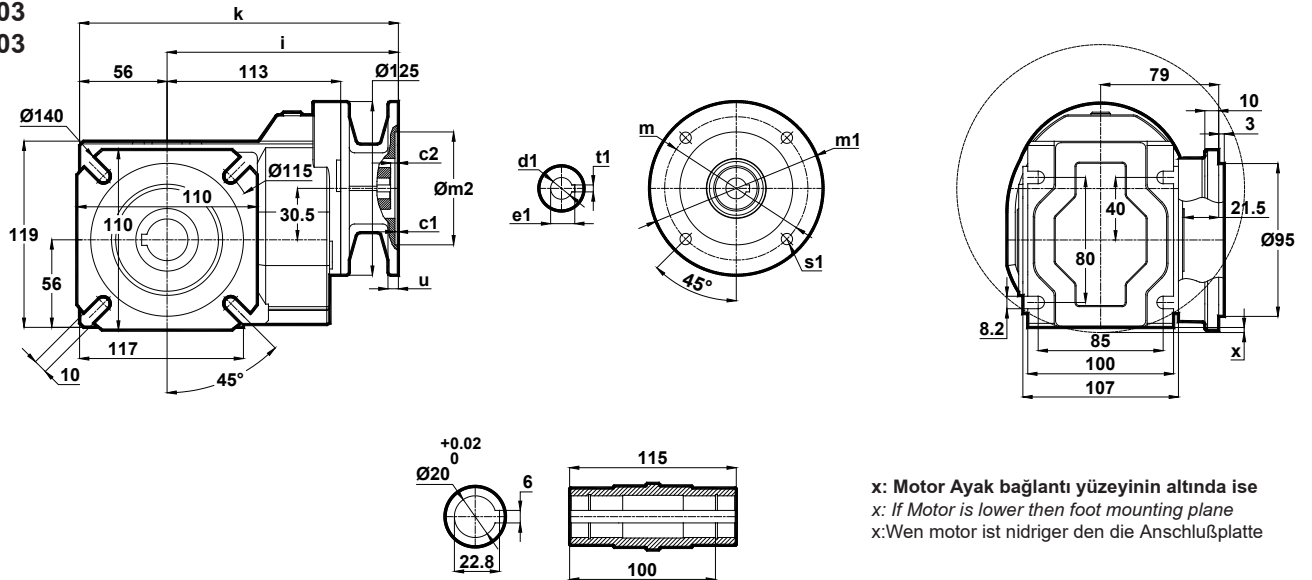

x: Motor Ayak bağlantı yüzeyinin altında ise  
x: If Motor is lower then foot mounting plane  
x:Wen motor ist nidriger den die Anschlußplatte

	c1	c2	s1	m	m1	m2	i	u	k	d1	t1	e1	x
63/B5	3.5	5	10	115	140	95	156	10	212	11	4	12.8	-
71/B5	4	4.5	11	130	160	110	157.5	12	213.5	14	5	16.3	-
80/B5	4	5	13	165	200	130	172.5	12	228.5	19	6	21.8	13.5
90/B5	4	5	13	165	200	130	172.5	12	228.5	24	8	27.3	13.5

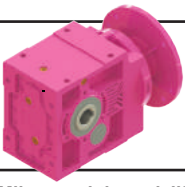

# Ölçü Sayfaları Dimension Pages Abmessungsseiten

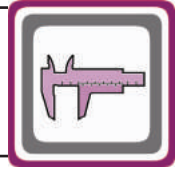

-Mil ucu çekirme deliği DIN 332 sayfa 2 / Tapped center hole to DIN 332, sheet 2 / Zentrierung mit gewinde DIN 332, Blatt 2

KN002.04  
KN003.04

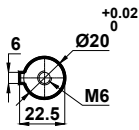
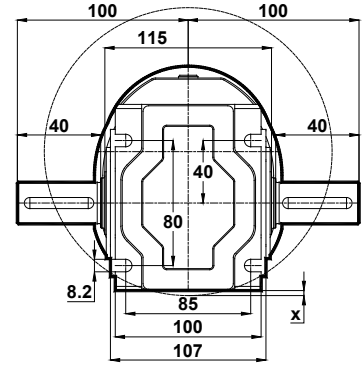
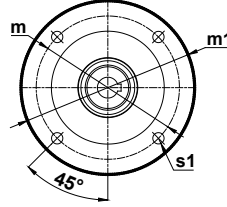
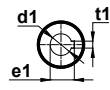
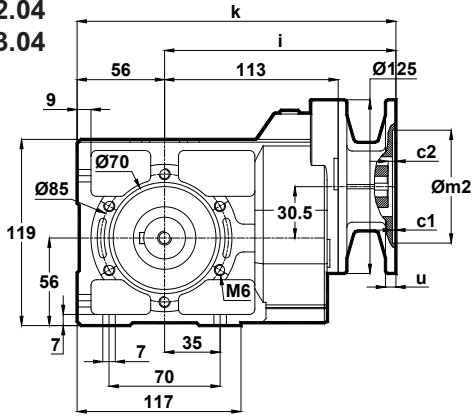

x: Motor Ayak bağlantı yüzeyinin altında ise  
x: If Motor is lower then foot mounting plane  
x: Wenn motor ist niedriger den die Anschlußplatte

	c1	c2	s1	m	m1	m2	i	u	k	d1	t1	e1	x
63/B5	3.5	5	10	115	140	95	156	10	212	11	4	12.8	-
71/B5	4	4.5	11	130	160	110	157.5	12	213.5	14	5	16.3	-
80/B5	4	5	13	165	200	130	172.5	12	228.5	19	6	21.8	13.5
90/B5	4	5	13	165	200	130	172.5	12	228.5	24	8	27.3	13.5

KN002.05  
KN003.05

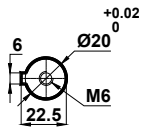
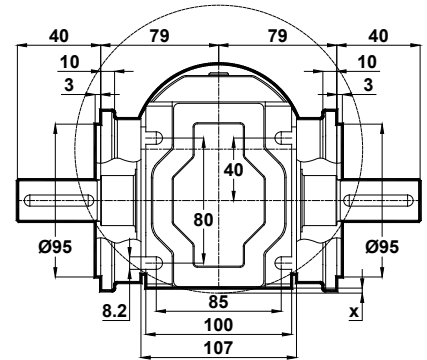
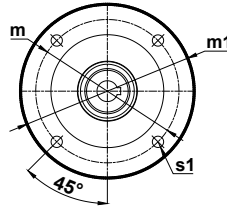
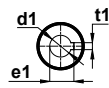
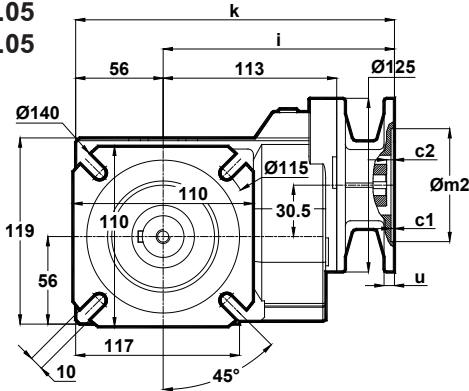

x: Motor Ayak bağlantı yüzeyinin altında ise  
x: If Motor is lower then foot mounting plane  
x: Wenn motor ist niedriger den die Anschlußplatte

	c1	c2	s1	m	m1	m2	i	u	k	d1	t1	e1	x
63/B5	3.5	5	10	115	140	95	156	10	212	11	4	12.8	-
71/B5	4	4.5	11	130	160	110	157.5	12	213.5	14	5	16.3	-
80/B5	4	5	13	165	200	130	172.5	12	228.5	19	6	21.8	13.5
90/B5	4	5	13	165	200	130	172.5	12	228.5	24	8	27.3	13.5

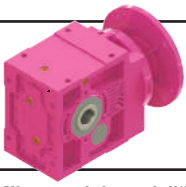

# Ölçü Sayfaları Dimension Pages Abmessungenseiten

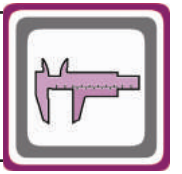

-Mil ucu çekirme deliği DIN 332 sayfa 2 / Tapped center hole to DIN 332, sheet 2 / Zentrierung mit gewinde DIN 332, Blatt 2

KN002.08  
KN003.08

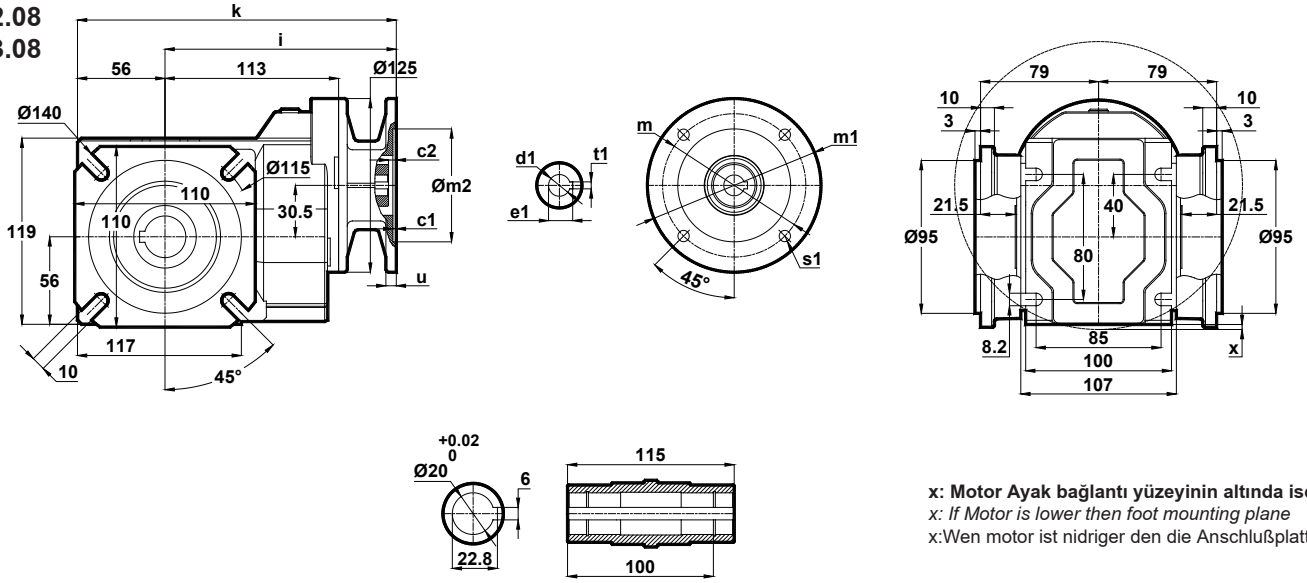

	c1	c2	s1	m	m1	m2	i	u	k	d1	t1	e1	x
63/B5	3.5	5	10	115	140	95	156	10	212	11	4	12.8	-
71/B5	4	4.5	11	130	160	110	157.5	12	213.5	14	5	16.3	-
80/B5	4	5	13	165	200	130	172.5	12	228.5	19	6	21.8	13.5
90/B5	4	5	13	165	200	130	172.5	12	228.5	24	8	27.3	13.5

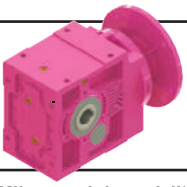

# Ölçü Sayfaları

## Dimension Pages

### Abmessungsseiten

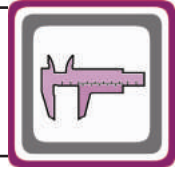

-Mil ucu çektirme deliği DIN 332 sayfa 2 / Tapped center hole to DIN 332, sheet 2 / Zentrierung mit gewinde DIN 332, Blatt 2

KN102.00  
KN103.00

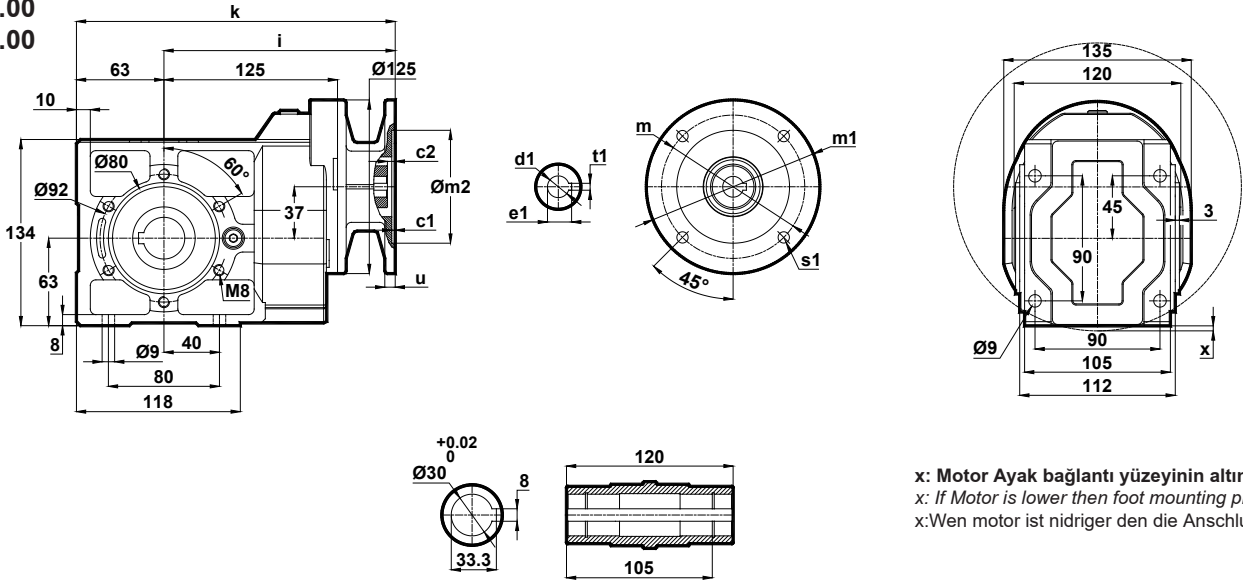

x: Motor Ayak bağlantı yüzeyinin altında ise  
x: If Motor is lower then foot mounting plane  
x:Wen motor ist nidriger den die Anschlußplatte

	c1	c2	s1	m	m1	m2	i	u	k	d1	t1	e1	x
63/B5	3.5	5	10	115	140	95	168	10	231	11	4	12.8	-
71/B5	4	4.5	11	130	160	110	169.5	12	232.5	14	5	16.3	-
80/B5	4	5	13	165	200	130	184.5	12	247.5	19	6	21.8	-
90/B5	4	5	13	165	200	130	184.5	12	247.5	24	8	27.3	-

KN102.01  
KN103.01

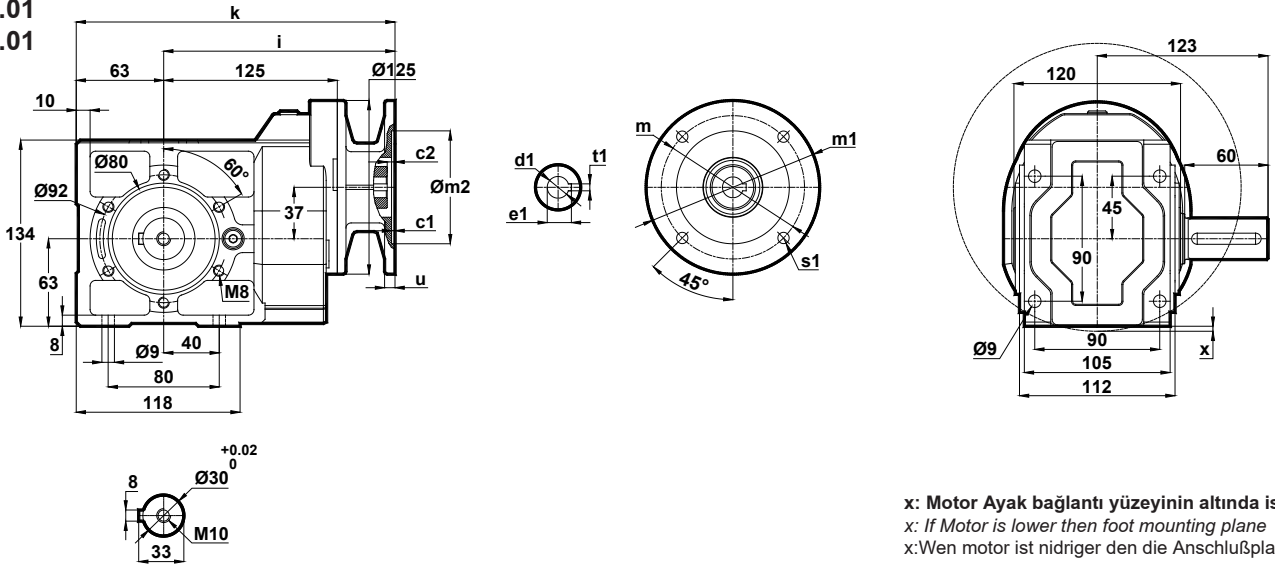

x: Motor Ayak bağlantı yüzeyinin altında ise  
x: If Motor is lower then foot mounting plane  
x:Wen motor ist nidriger den die Anschlußplatte

	c1	c2	s1	m	m1	m2	i	u	k	d1	t1	e1	x
63/B5	3.5	5	10	115	140	95	168	10	231	11	4	12.8	-
71/B5	4	4.5	11	130	160	110	169.5	12	232.5	14	5	16.3	-
80/B5	4	5	13	165	200	130	184.5	12	247.5	19	6	21.8	-
90/B5	4	5	13	165	200	130	184.5	12	247.5	24	8	27.3	-

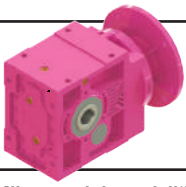

# Ölçü Sayfaları Dimension Pages Abmessungsseiten

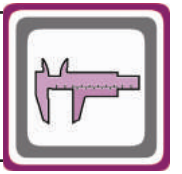

-Mil ucu çekirme deliği DIN 332 sayfa 2 / Tapped center hole to DIN 332, sheet 2 / Zentrierung mit gewinde DIN 332, Blatt 2

KN102.02  
KN103.02

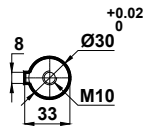
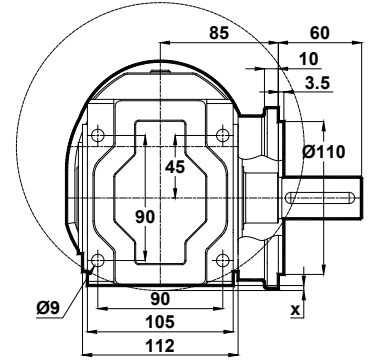
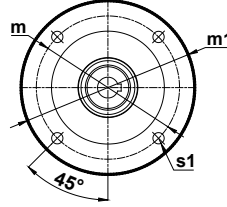
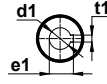
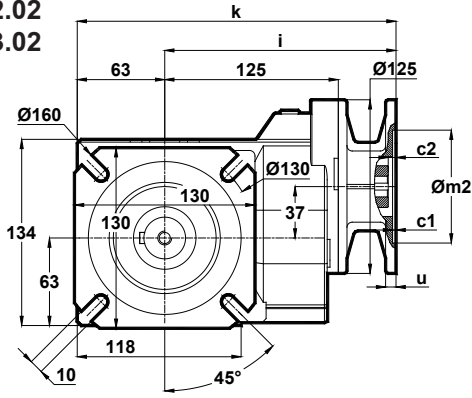

x: Motor Ayak bağlantı yüzeyinin altında ise  
x: If Motor is lower then foot mounting plane  
x:Wen motor ist nidriger den die Anschlußplatte

	c1	c2	s1	m	m1	m2	i	u	k	d1	t1	e1	x
63/B5	3.5	5	10	115	140	95	168	10	231	11	4	12.8	-
71/B5	4	4.5	11	130	160	110	169.5	12	232.5	14	5	16.3	-
80/B5	4	5	13	165	200	130	184.5	12	247.5	19	6	21.8	-
90/B5	4	5	13	165	200	130	184.5	12	247.5	24	8	27.3	-

KN102.03  
KN103.03

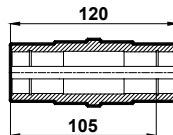
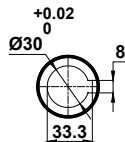
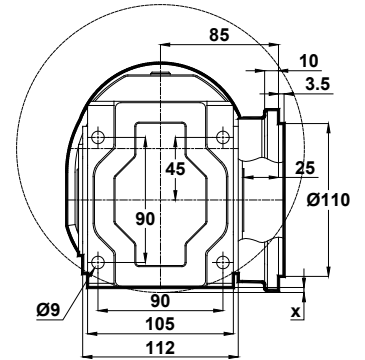
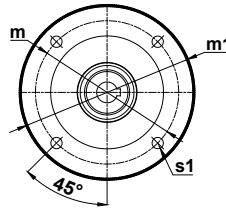
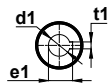
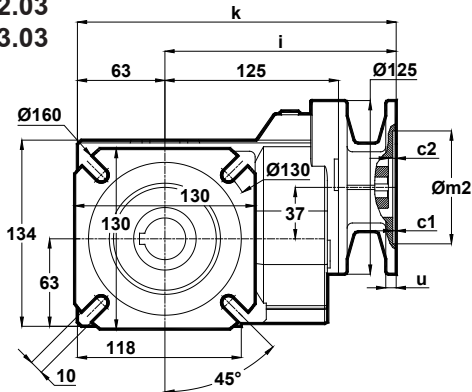

x: Motor Ayak bağlantı yüzeyinin altında ise  
x: If Motor is lower then foot mounting plane  
x:Wen motor ist nidriger den die Anschlußplatte

	c1	c2	s1	m	m1	m2	i	u	k	d1	t1	e1	x
63/B5	3.5	5	10	115	140	95	168	10	231	11	4	12.8	-
71/B5	4	4.5	11	130	160	110	169.5	12	232.5	14	5	16.3	-
80/B5	4	5	13	165	200	130	184.5	12	247.5	19	6	21.8	-
90/B5	4	5	13	165	200	130	184.5	12	247.5	24	8	27.3	-

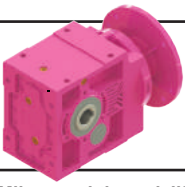

# Ölçü Sayfaları Dimension Pages Abmessungsseiten

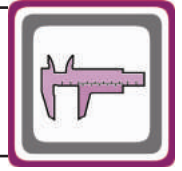

-Mil ucu çektirme deliği DIN 332 sayfa 2 / Tapped center hole to DIN 332, sheet 2 / Zentrierung mit gewinde DIN 332, Blatt 2

KN102.04  
KN103.04

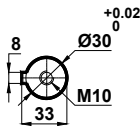
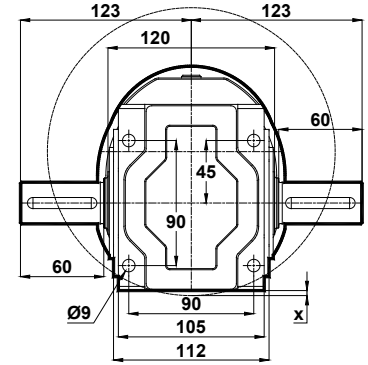
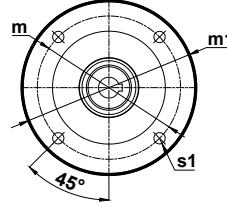
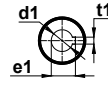
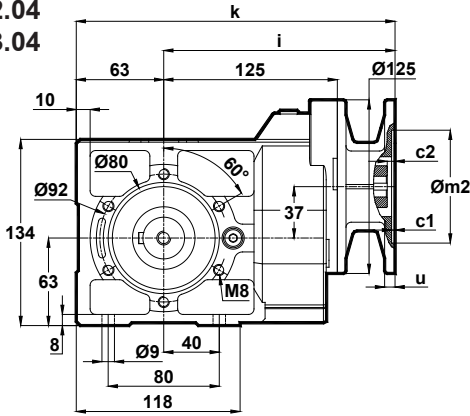

x: Motor Ayak bağlantı yüzeyinin altında ise  
x: If Motor is lower then foot mounting plane  
x: Wenn motor ist niedriger den die Anschlußplatte

	c1	c2	s1	m	m1	m2	i	u	k	d1	t1	e1	x
63/B5	3.5	5	10	115	140	95	168	10	231	11	4	12.8	-
71/B5	4	4.5	11	130	160	110	169.5	12	232.5	14	5	16.3	-
80/B5	4	5	13	165	200	130	184.5	12	247.5	19	6	21.8	-
90/B5	4	5	13	165	200	130	184.5	12	247.5	24	8	27.3	-

KN102.05  
KN103.05

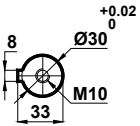
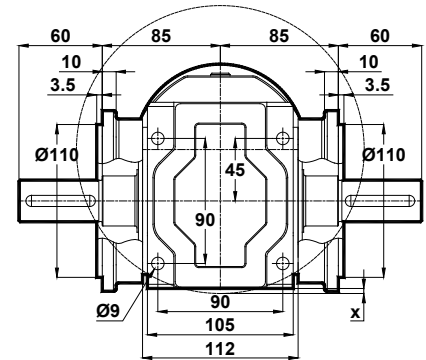
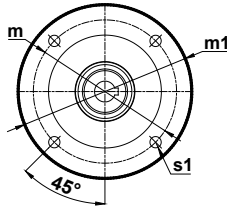
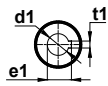
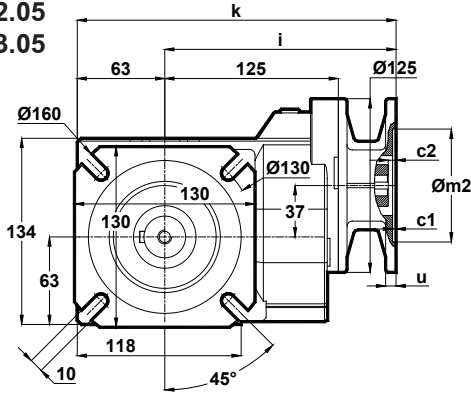

x: Motor Ayak bağlantı yüzeyinin altında ise  
x: If Motor is lower then foot mounting plane  
x: Wenn motor ist niedriger den die Anschlußplatte

	c1	c2	s1	m	m1	m2	i	u	k	d1	t1	e1	x
63/B5	3.5	5	10	115	140	95	168	10	231	11	4	12.8	-
71/B5	4	4.5	11	130	160	110	169.5	12	232.5	14	5	16.3	-
80/B5	4	5	13	165	200	130	184.5	12	247.5	19	6	21.8	-
90/B5	4	5	13	165	200	130	184.5	12	247.5	24	8	27.3	-

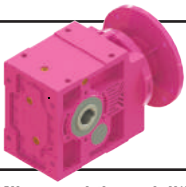

# Ölçü Sayfaları

## Dimension Pages

### Abmessungsseiten

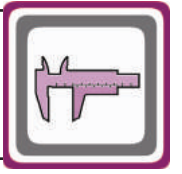

-Mil ucu çekirme deliği DIN 332 sayfa 2 / Tapped center hole to DIN 332, sheet 2 / Zentrierung mit gewinde DIN 332, Blatt 2

KN102.08  
KN103.08

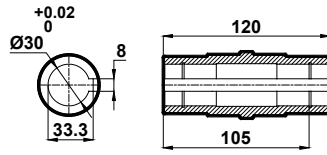
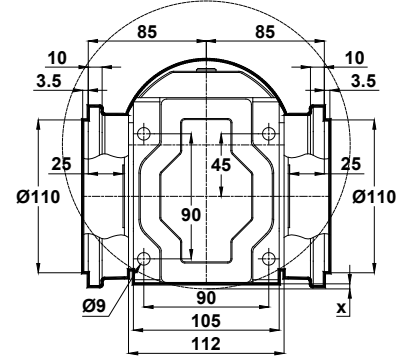
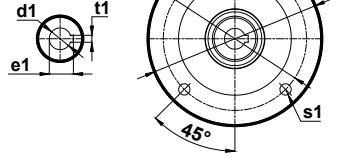
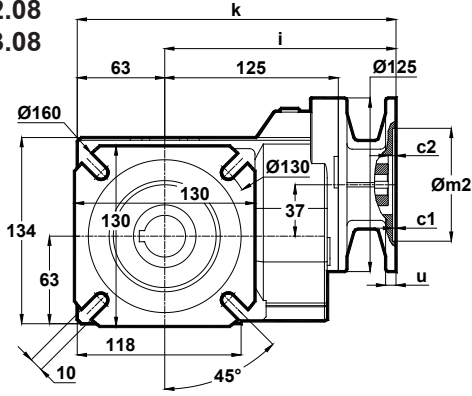

x: Motor Ayak bağlantı yüzeyinin altında ise  
x: If Motor is lower then foot mounting plane  
x: Wenn motor ist niedriger den die Anschlußplatte

	c1	c2	s1	m	m1	m2	i	u	k	d1	t1	e1	x
63/B5	3.5	5	10	115	140	95	168	10	231	11	4	12.8	-
71/B5	4	4.5	11	130	160	110	169.5	12	232.5	14	5	16.3	-
80/B5	4	5	13	165	200	130	184.5	12	247.5	19	6	21.8	-
90/B5	4	5	13	165	200	130	184.5	12	247.5	24	8	27.3	-

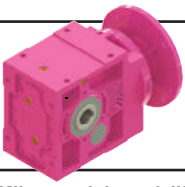

# Ölçü Sayfaları Dimension Pages Abmessungsseiten

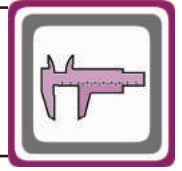

-Mil ucu çekirme deliği DIN 332 sayfa 2 / Tapped center hole to DIN 332, sheet 2 / Zentrierung mit gewinde DIN 332, Blatt 2

KN202.00  
KN203.00

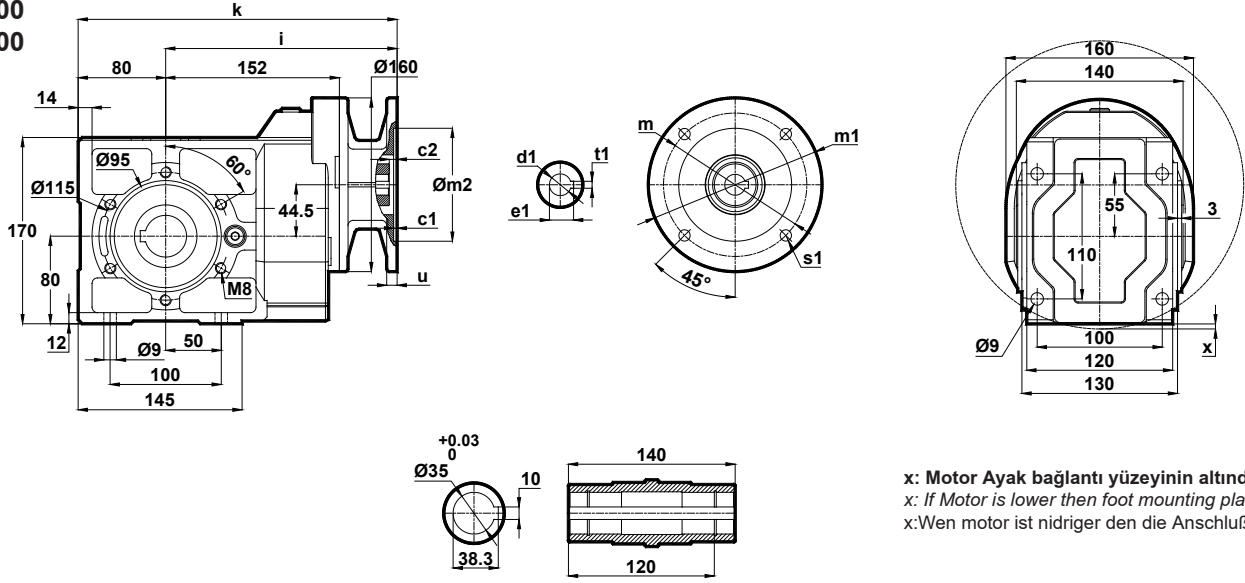

x: Motor Ayak bağlantı yüzeyinin altında ise  
x: If Motor is lower then foot mounting plane  
x: Wenn motor ist niedriger den die Anschlußplatte

	c1	c2	s1	m	m1	m2	i	u	k	d1	t1	e1	x
63/B5	4	8	9	115	140	95	225.5	12	305.5	11	4	12.8	-
71/B5	4	8.5	11	130	160	110	196.5	12	276.5	14	5	16.3	-
80/B5	4	5	13	165	200	130	225.5	12	305.5	19	6	21.8	-
90/B5	4	5	13	165	200	130	225.5	12	305.5	24	8	27.3	-
100/B5	4	5.5	15	215	250	180	218.5	12	298.5	28	8	31.3	0.5
112/B5	4	5.5	15	215	250	180	218.5	12	298.5	28	8	31.3	0.5

KN202.01  
KN203.01

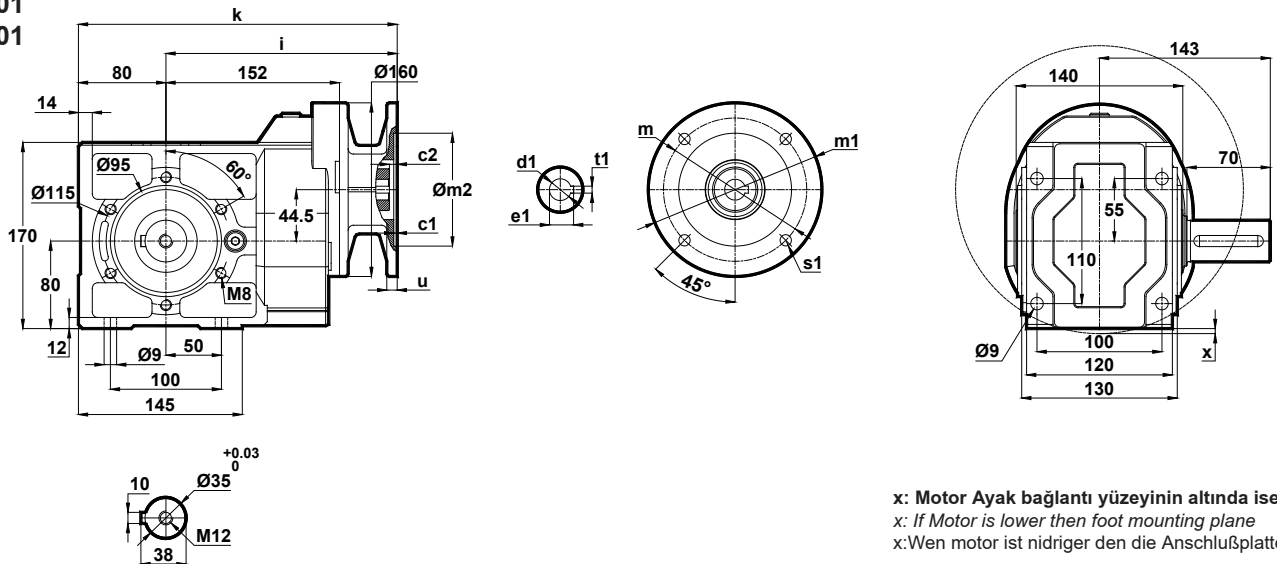

x: Motor Ayak bağlantı yüzeyinin altında ise  
x: If Motor is lower then foot mounting plane  
x: Wenn motor ist niedriger den die Anschlußplatte

	c1	c2	s1	m	m1	m2	i	u	k	d1	t1	e1	x
63/B5	4	8	9	115	140	95	225.5	12	305.5	11	4	12.8	-
71/B5	4	8.5	11	130	160	110	196.5	12	276.5	14	5	16.3	-
80/B5	4	5	13	165	200	130	225.5	12	305.5	19	6	21.8	-
90/B5	4	5	13	165	200	130	225.5	12	305.5	24	8	27.3	-
100/B5	4	5.5	15	215	250	180	218.5	12	298.5	28	8	31.3	0.5
112/B5	4	5.5	15	215	250	180	218.5	12	298.5	28	8	31.3	0.5

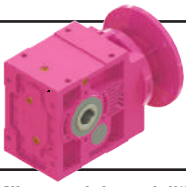

# Ölçü Sayfaları

## Dimension Pages

### Abmessungsseiten

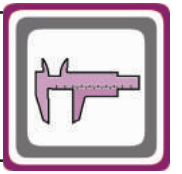

-Mil ucu çekirme deliği DIN 332 sayfa 2 / Tapped center hole to DIN 332, sheet 2 / Zentrierung mit gewinde DIN 332, Blatt 2

KN202.02  
KN203.02

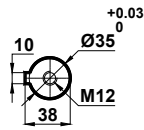
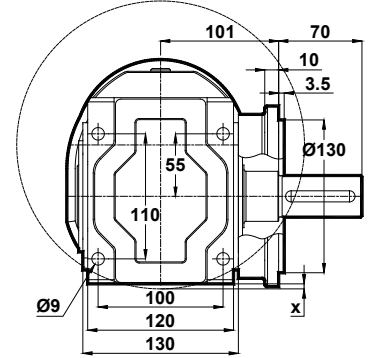
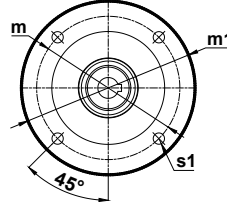
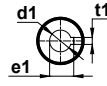
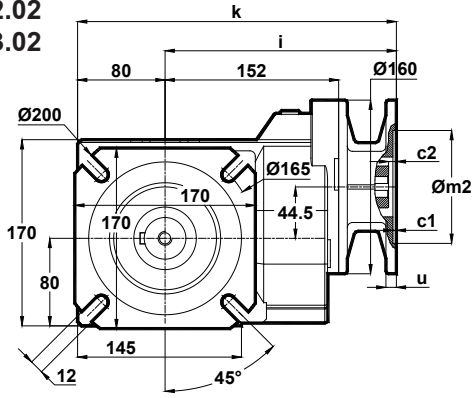

x: Motor Ayak bağlantı yüzeyinin altında ise  
x: If Motor is lower then foot mounting plane  
x:Wen motor ist nidriger den die Anschlußplatte

	c1	c2	s1	m	m1	m2	i	u	k	d1	t1	e1	x
63/B5	4	8	9	115	140	95	225.5	12	305.5	11	4	12.8	-
71/B5	4	8.5	11	130	160	110	196.5	12	276.5	14	5	16.3	-
80/B5	4	5	13	165	200	130	225.5	12	305.5	19	6	21.8	-
90/B5	4	5	13	165	200	130	225.5	12	305.5	24	8	27.3	-
100/B5	4	5.5	15	215	250	180	218.5	12	298.5	28	8	31.3	0.5
112/B5	4	5.5	15	215	250	180	218.5	12	298.5	28	8	31.3	0.5

KN202.03  
KN203.03

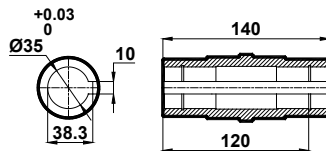
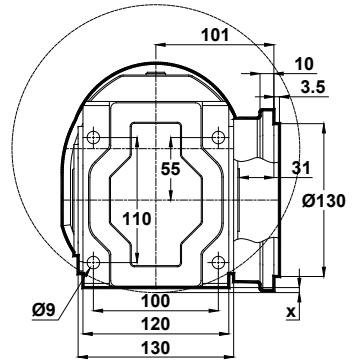
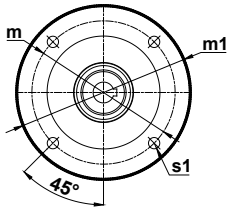
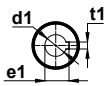
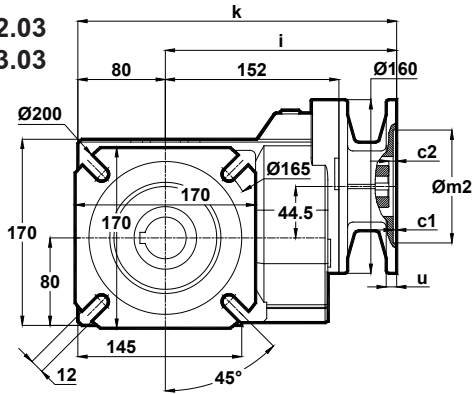

x: Motor Ayak bağlantı yüzeyinin altında ise  
x: If Motor is lower then foot mounting plane  
x:Wen motor ist nidriger den die Anschlußplatte

	c1	c2	s1	m	m1	m2	i	u	k	d1	t1	e1	x
63/B5	4	8	9	115	140	95	225.5	12	305.5	11	4	12.8	-
71/B5	4	8.5	11	130	160	110	196.5	12	276.5	14	5	16.3	-
80/B5	4	5	13	165	200	130	225.5	12	305.5	19	6	21.8	-
90/B5	4	5	13	165	200	130	225.5	12	305.5	24	8	27.3	-
100/B5	4	5.5	15	215	250	180	218.5	12	298.5	28	8	31.3	0.5
112/B5	4	5.5	15	215	250	180	218.5	12	298.5	28	8	31.3	0.5

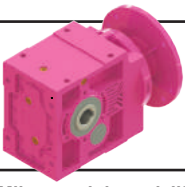

# Ölçü Sayfaları Dimension Pages Abmessungsseiten

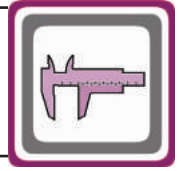

-Mil ucu çekirme deliği DIN 332 sayfa 2 / Tapped center hole to DIN 332, sheet 2 / Zentrierung mit gewinde DIN 332, Blatt 2

KN202.04  
KN203.04

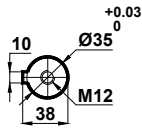
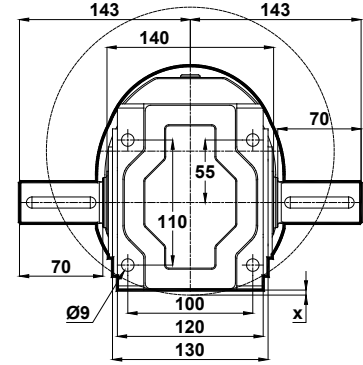
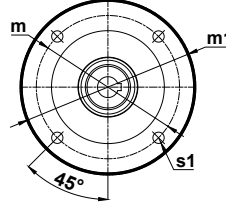
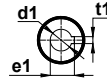
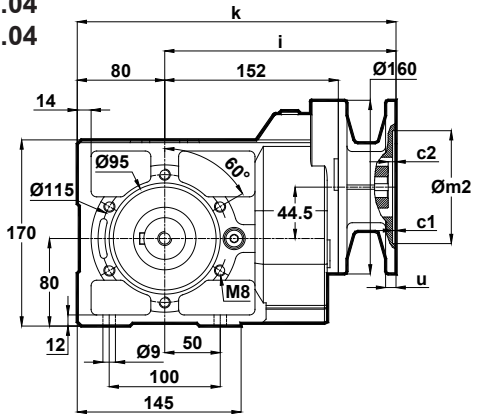

x: Motor Ayak bağlantı yüzeyinin altında ise  
x: If Motor is lower then foot mounting plane  
x:Wen motor ist nidriger den die Anschlußplatte

	c1	c2	s1	m	m1	m2	i	u	k	d1	t1	e1	x
63/B5	4	8	9	115	140	95	225.5	12	305.5	11	4	12.8	-
71/B5	4	8.5	11	130	160	110	196.5	12	276.5	14	5	16.3	-
80/B5	4	5	13	165	200	130	225.5	12	305.5	19	6	21.8	-
90/B5	4	5	13	165	200	130	225.5	12	305.5	24	8	27.3	-
100/B5	4	5.5	15	215	250	180	218.5	12	298.5	28	8	31.3	0.5
112/B5	4	5.5	15	215	250	180	218.5	12	298.5	28	8	31.3	0.5

KN202.05  
KN203.05

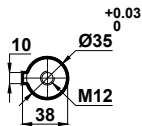
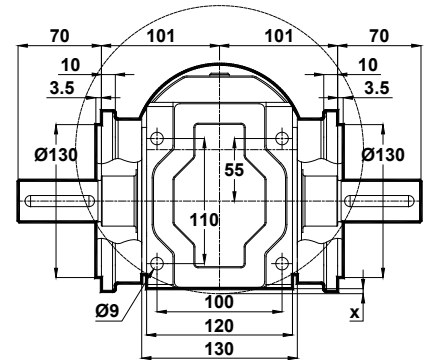
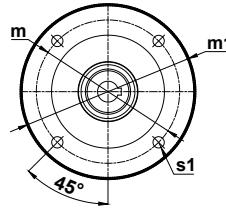
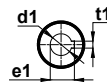
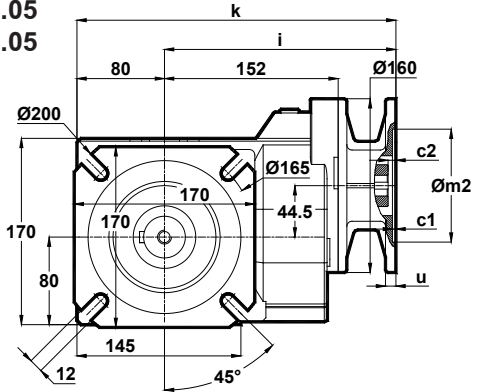

x: Motor Ayak bağlantı yüzeyinin altında ise  
x: If Motor is lower then foot mounting plane  
x:Wen motor ist nidriger den die Anschlußplatte

	c1	c2	s1	m	m1	m2	i	u	k	d1	t1	e1	x
63/B5	4	8	9	115	140	95	225.5	12	305.5	11	4	12.8	-
71/B5	4	8.5	11	130	160	110	196.5	12	276.5	14	5	16.3	-
80/B5	4	5	13	165	200	130	225.5	12	305.5	19	6	21.8	-
90/B5	4	5	13	165	200	130	225.5	12	305.5	24	8	27.3	-
100/B5	4	5.5	15	215	250	180	218.5	12	298.5	28	8	31.3	0.5
112/B5	4	5.5	15	215	250	180	218.5	12	298.5	28	8	31.3	0.5

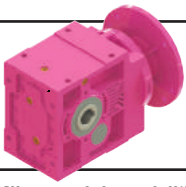

# Ölçü Sayfaları

## Dimension Pages

### Abmessungsseiten

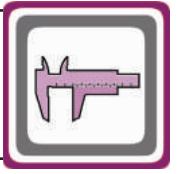

-Mil ucu çektirme deliği DIN 332 sayfa 2 / Tapped center hole to DIN 332, sheet 2 / Zentrierung mit gewinde DIN 332, Blatt 2

KN202.08  
KN203.08

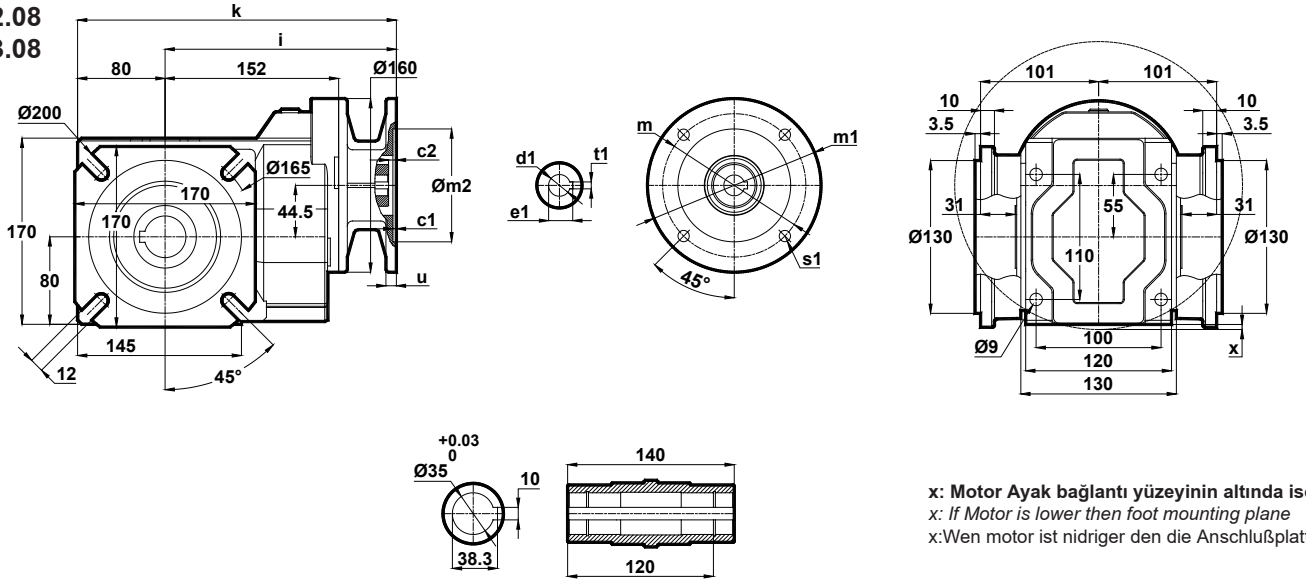

x: Motor Ayak bağlantı yüzeyinin altında ise  
x: If Motor is lower then foot mounting plane  
x: Wenn motor ist niedriger den die Anschlußplatte

	c1	c2	s1	m	m1	m2	i	u	k	d1	t1	e1	x
63/B5	4	8	9	115	140	95	225.5	12	305.5	11	4	12.8	-
71/B5	4	8.5	11	130	160	110	196.5	12	276.5	14	5	16.3	-
80/B5	4	5	13	165	200	130	225.5	12	305.5	19	6	21.8	-
90/B5	4	5	13	165	200	130	225.5	12	305.5	24	8	27.3	-
100/B5	4	5.5	15	215	250	180	218.5	12	298.5	28	8	31.3	0.5
112/B5	4	5.5	15	215	250	180	218.5	12	298.5	28	8	31.3	0.5

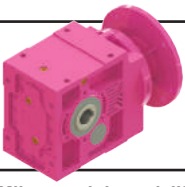

# Ölçü Sayfaları

## Dimension Pages

### Abmessungenseiten

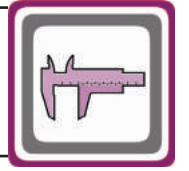

-Mil ucu çekirme deliği DIN 332 sayfa 2 / Tapped center hole to DIN 332, sheet 2 / Zentrierung mit gewinde DIN 332, Blatt 2

#### KN273.00

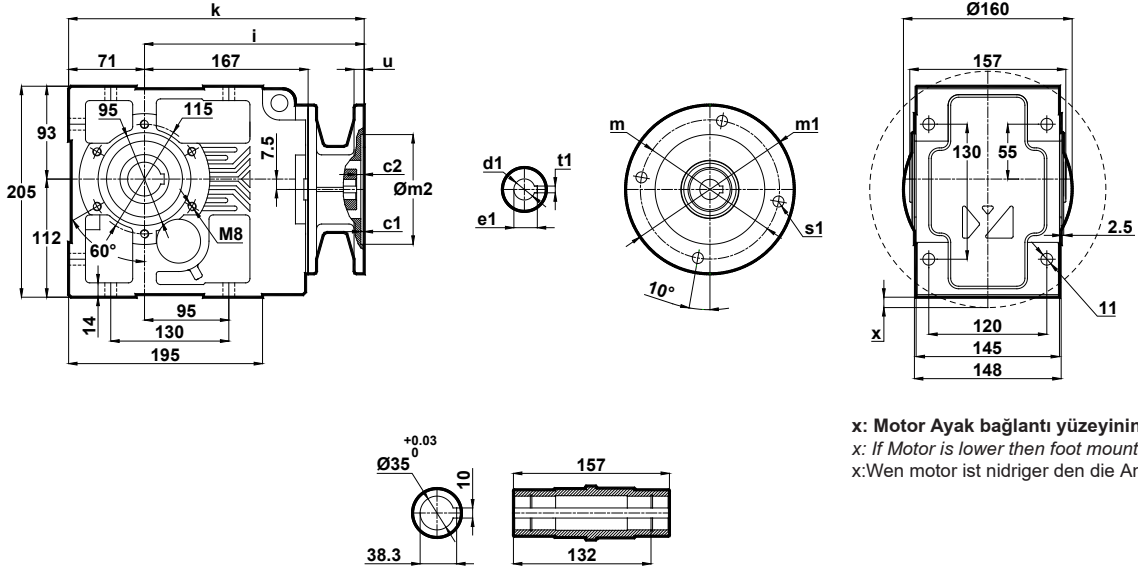

x: Motor Ayak bağlantı yüzeyinin altında ise  
x: If Motor is lower then foot mounting plane  
x:Wen motor ist niedriger den die Anschlußplatte

	c1	c2	s1	m	m1	m2	i	u	k	d1	t1	e1	x
63/B5	4	8	9	115	140	95	241	12	312	11	4	12.8	-
71/B5	4	8.5	11	130	160	110	212	12	283	14	5	16.3	-
80/B5	4	5	13	165	200	130	241	12	312	19	6	21.8	-
90/B5	4	5	13	165	200	130	241	12	312	24	8	27.3	-
100/B5	4	5.5	15	215	250	180	234	12	305	28	8	31.3	20.5
112/B5	4	5.5	15	215	250	180	234	12	305	28	8	31.3	20.5

#### KN273.01

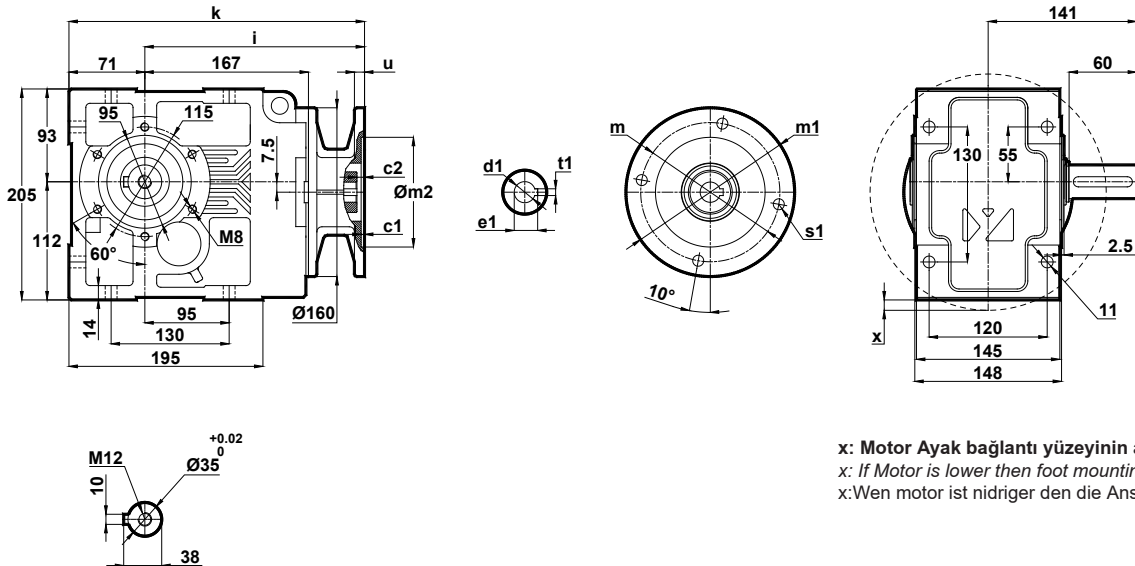

x: Motor Ayak bağlantı yüzeyinin altında ise  
x: If Motor is lower then foot mounting plane  
x:Wen motor ist niedriger den die Anschlußplatte

	c1	c2	s1	m	m1	m2	i	u	k	d1	t1	e1	x
63/B5	4	8	9	115	140	95	241	12	312	11	4	12.8	-
71/B5	4	8.5	11	130	160	110	212	12	283	14	5	16.3	-
80/B5	4	5	13	165	200	130	241	12	312	19	6	21.8	-
90/B5	4	5	13	165	200	130	241	12	312	24	8	27.3	-
100/B5	4	5.5	15	215	250	180	234	12	305	28	8	31.3	20.5
112/B5	4	5.5	15	215	250	180	234	12	305	28	8	31.3	20.5

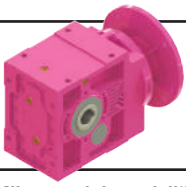

# Ölçü Sayfaları

## Dimension Pages

### Abmessungsseiten

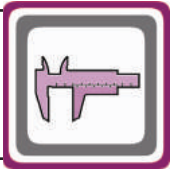

-Mil ucu çektirme deliği DIN 332 sayfa 2 / Tapped center hole to DIN 332, sheet 2 / Zentrierung mit gewinde DIN 332, Blatt 2

#### KN273.02

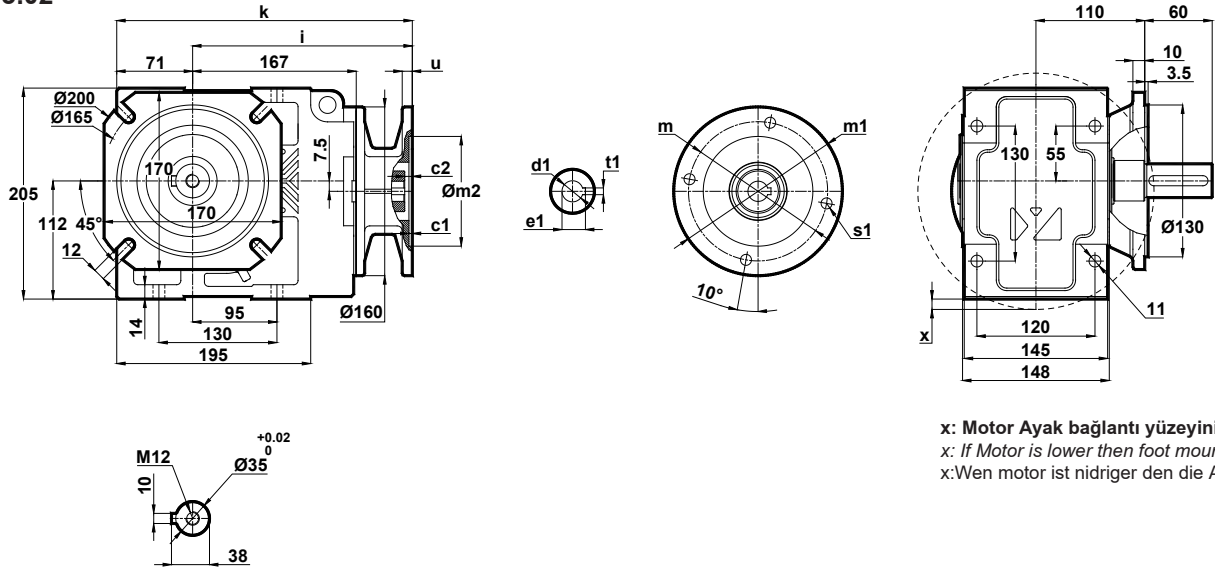

x: Motor Ayak bağlantı yüzeyinin altında ise  
 x: If Motor is lower then foot mounting plane  
 x:Wen motor ist nidriger den die Anschlußplatte

	c1	c2	s1	m	m1	m2	i	u	k	d1	t1	e1	x
63/B5	4	8	9	115	140	95	241	12	312	11	4	12.8	-
71/B5	4	8.5	11	130	160	110	212	12	283	14	5	16.3	-
80/B5	4	5	13	165	200	130	241	12	312	19	6	21.8	-
90/B5	4	5	13	165	200	130	241	12	312	24	8	27.3	-
100/B5	4	5.5	15	215	250	180	234	12	305	28	8	31.3	20.5
112/B5	4	5.5	15	215	250	180	234	12	305	28	8	31.3	20.5

#### KN273.03

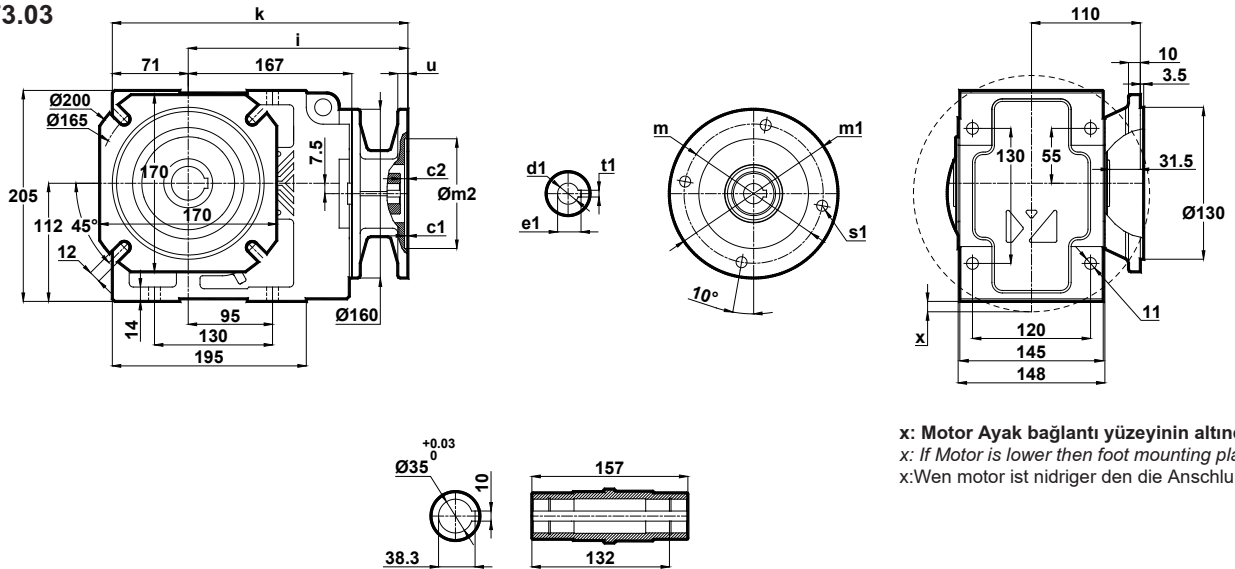

x: Motor Ayak bağlantı yüzeyinin altında ise  
 x: If Motor is lower then foot mounting plane  
 x:Wen motor ist nidriger den die Anschlußplatte

	c1	c2	s1	m	m1	m2	i	u	k	d1	t1	e1	x
63/B5	4	8	9	115	140	95	241	12	312	11	4	12.8	-
71/B5	4	8.5	11	130	160	110	212	12	283	14	5	16.3	-
80/B5	4	5	13	165	200	130	241	12	312	19	6	21.8	-
90/B5	4	5	13	165	200	130	241	12	312	24	8	27.3	-
100/B5	4	5.5	15	215	250	180	234	12	305	28	8	31.3	20.5
112/B5	4	5.5	15	215	250	180	234	12	305	28	8	31.3	20.5

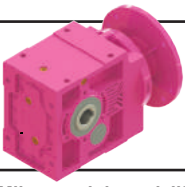

# Ölçü Sayfaları Dimension Pages Abmessungsseiten

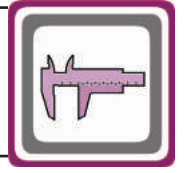

-Mil ucu çekirme deliği DIN 332 sayfa 2 / Tapped center hole to DIN 332, sheet 2 / Zentrierung mit gewinde DIN 332, Blatt 2

## KN273.04

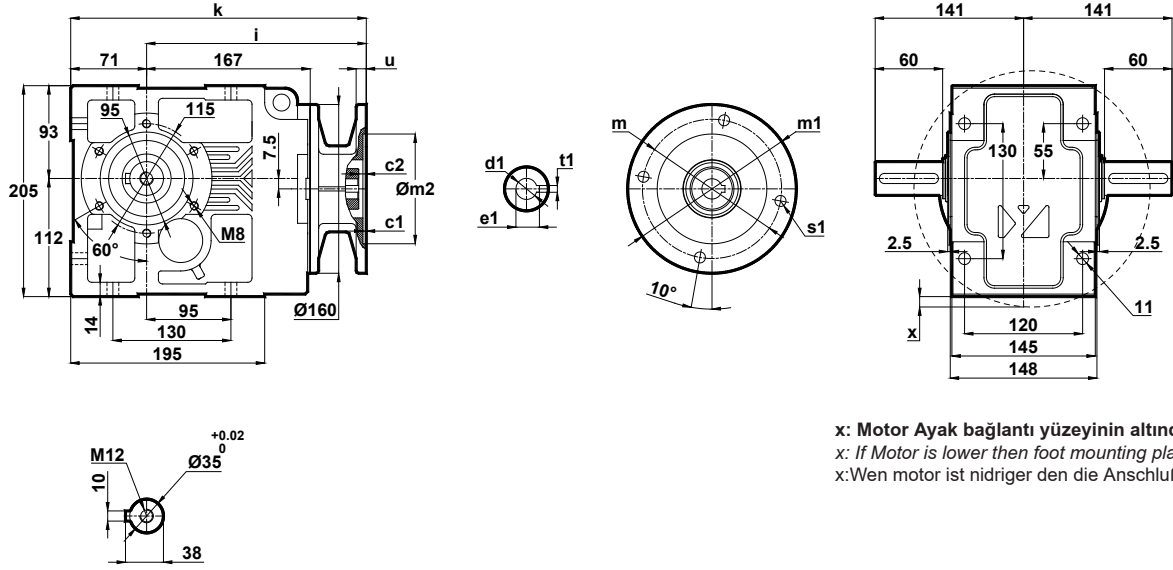

x: Motor ayak bağlantı yüzeyinin altında ise  
x: If Motor is lower then foot mounting plane  
x: Wenn motor ist niedriger den die Anschlußplatte

	c1	c2	s1	m	m1	m2	i	u	k	d1	t1	e1	x
63/B5	4	8	9	115	140	95	241	12	312	11	4	12.8	-
71/B5	4	8.5	11	130	160	110	212	12	283	14	5	16.3	-
80/B5	4	5	13	165	200	130	241	12	312	19	6	21.8	-
90/B5	4	5	13	165	200	130	241	12	312	24	8	27.3	-
100/B5	4	5.5	15	215	250	180	234	12	305	28	8	31.3	20.5
112/B5	4	5.5	15	215	250	180	234	12	305	28	8	31.3	20.5

## KN273.05

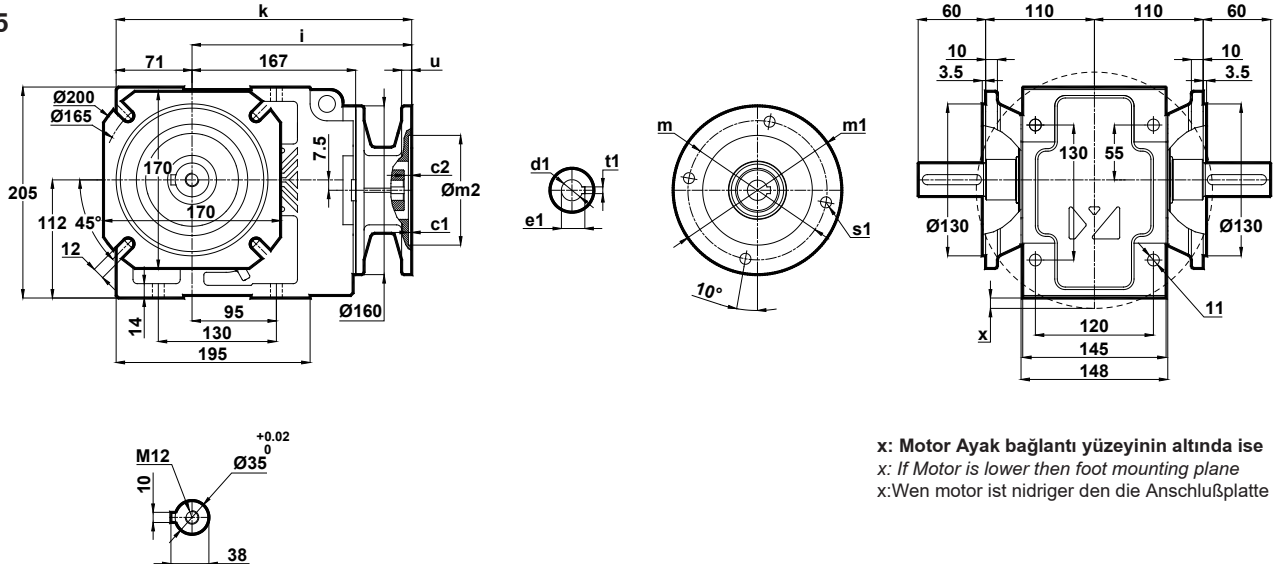

x: Motor ayak bağlantı yüzeyinin altında ise  
x: If Motor is lower then foot mounting plane  
x: Wenn motor ist niedriger den die Anschlußplatte

	c1	c2	s1	m	m1	m2	i	u	k	d1	t1	e1	x
63/B5	4	8	9	115	140	95	241	12	312	11	4	12.8	-
71/B5	4	8.5	11	130	160	110	212	12	283	14	5	16.3	-
80/B5	4	5	13	165	200	130	241	12	312	19	6	21.8	-
90/B5	4	5	13	165	200	130	241	12	312	24	8	27.3	-
100/B5	4	5.5	15	215	250	180	234	12	305	28	8	31.3	20.5
112/B5	4	5.5	15	215	250	180	234	12	305	28	8	31.3	20.5

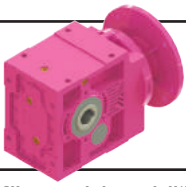

# Ölçü Sayfaları Dimension Pages Abmessungsseiten

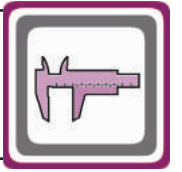

-Mil ucu çektirme deliği DIN 332 sayfa 2 / Tapped center hole to DIN 332, sheet 2 / Zentrierung mit gewinde DIN 332, Blatt 2

KN273.08

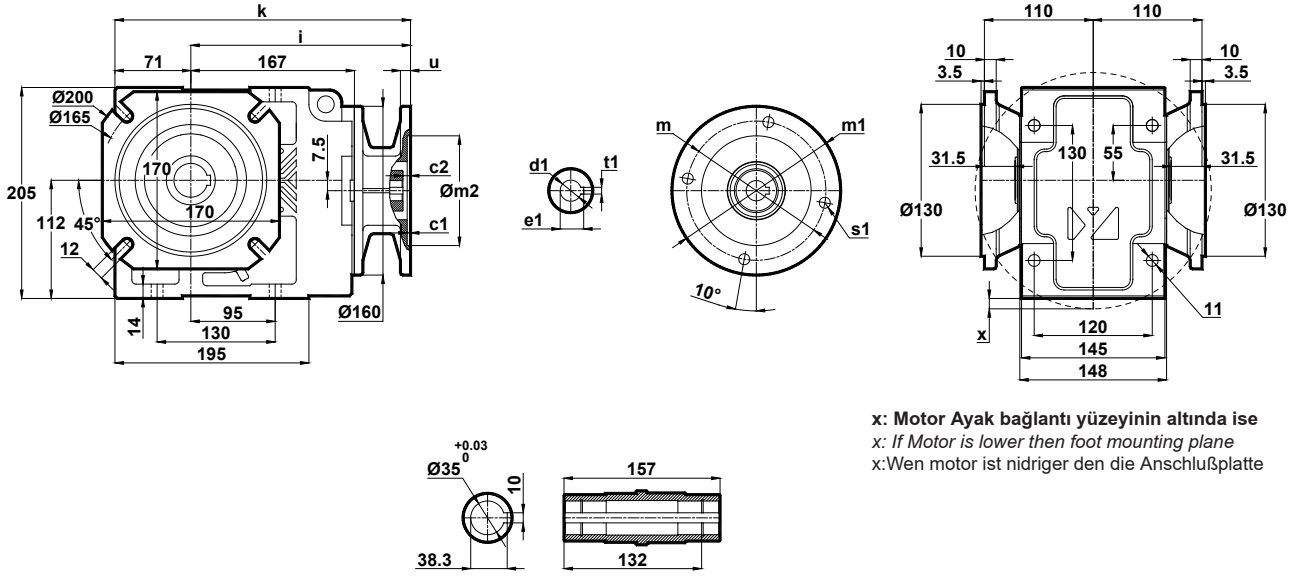

x: Motor Ayak bağlantı yüzeyinin altında ise  
x: If Motor is lower then foot mounting plane  
x: Wenn motor ist niedriger den die Anschlußplatte

	c1	c2	s1	m	m1	m2	i	u	k	d1	t1	e1	x
63/B5	4	8	9	115	140	95	241	12	312	11	4	12.8	-
71/B5	4	8.5	11	130	160	110	212	12	283	14	5	16.3	-
80/B5	4	5	13	165	200	130	241	12	312	19	6	21.8	-
90/B5	4	5	13	165	200	130	241	12	312	24	8	27.3	-
100/B5	4	5.5	15	215	250	180	234	12	305	28	8	31.3	20.5
112/B5	4	5.5	15	215	250	180	234	12	305	28	8	31.3	20.5

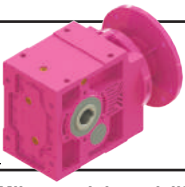

# Ölçü Sayfaları Dimension Pages Abmessungsseiten

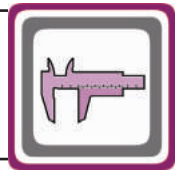

-Mil ucu çekirme deliği DIN 332 sayfa 2 / Tapped center hole to DIN 332, sheet 2 / Zentrierung mit gewinde DIN 332, Blatt 2

KN275.00  
KN276.00

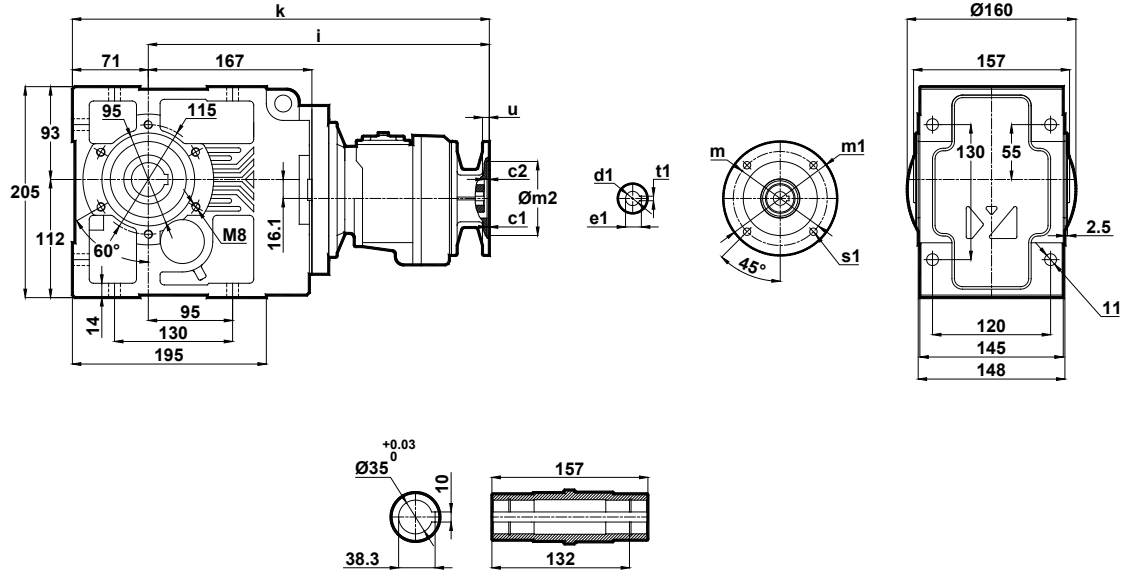

	c1	c2	s1	m	m1	m2	i	u	k	d1	t1	e1
63/B5	3.5	5	10	115	140	95	356	10	427	11	4	12.8
71/B5	4	4.5	11	130	160	110	358	12	429	14	5	16.3
80/B5	4	5	13	165	200	130	373	12	444	19	6	21.8

KN275.01  
KN276.01

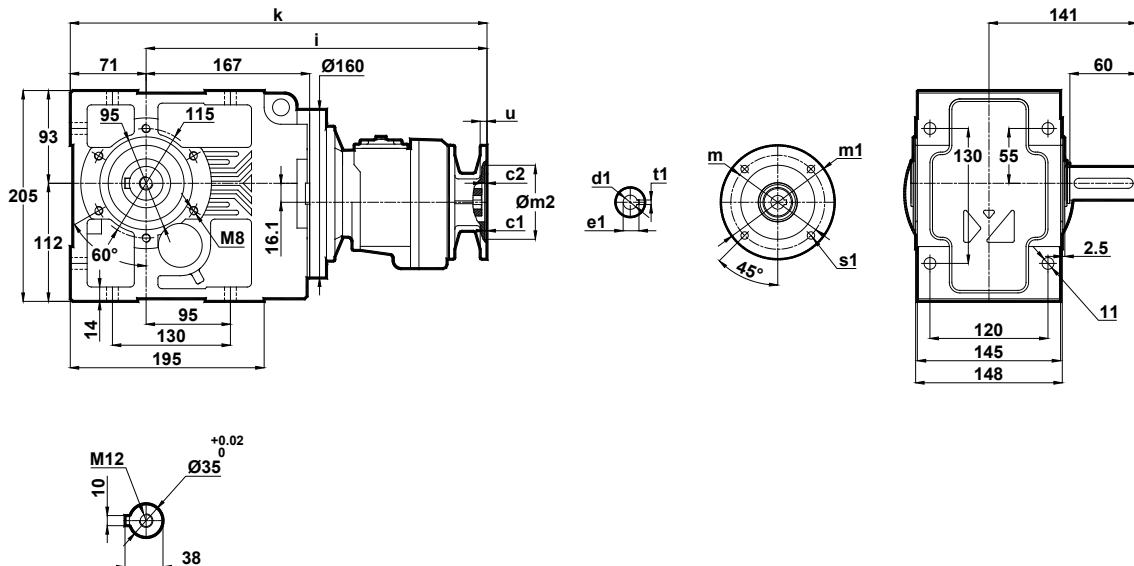

	c1	c2	s1	m	m1	m2	i	u	k	d1	t1	e1
63/B5	3.5	5	10	115	140	95	356	10	427	11	4	12.8
71/B5	4	4.5	11	130	160	110	358	12	429	14	5	16.3
80/B5	4	5	13	165	200	130	373	12	444	19	6	21.8

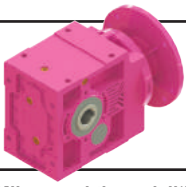

# Ölçü Sayfaları Dimension Pages Abmessungsseiten

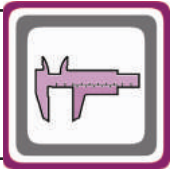

-Mil ucu çekirme deliği DIN 332 sayfa 2 / Tapped center hole to DIN 332, sheet 2 / Zentrierung mit gewinde DIN 332, Blatt 2

KN275.02  
KN276.02

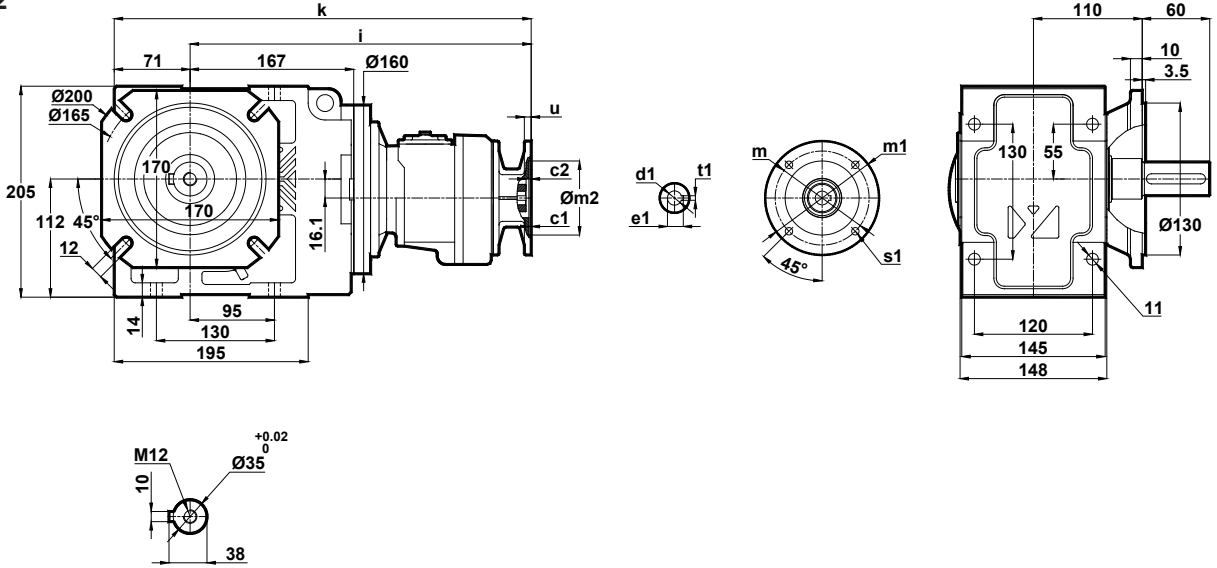

	c1	c2	s1	m	m1	m2	i	u	k	d1	t1	e1
63/B5	3.5	5	10	115	140	95	356	10	427	11	4	12.8
71/B5	4	4.5	11	130	160	110	358	12	429	14	5	16.3
80/B5	4	5	13	165	200	130	373	12	444	19	6	21.8

KN275.03  
KN276.03

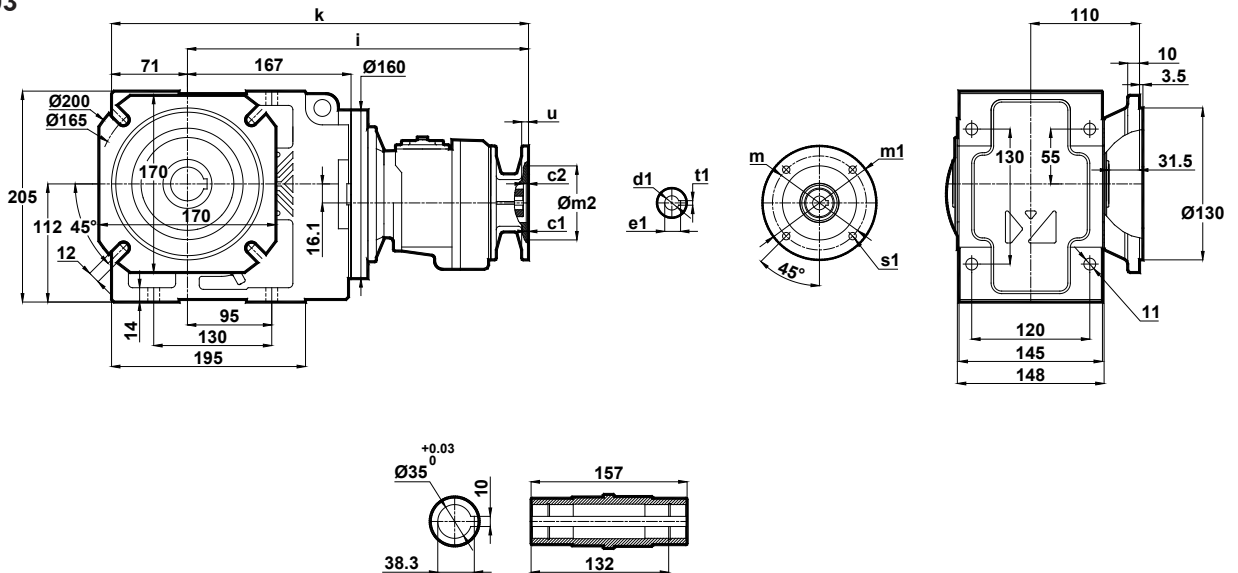

	c1	c2	s1	m	m1	m2	i	u	k	d1	t1	e1
63/B5	3.5	5	10	115	140	95	356	10	427	11	4	12.8
71/B5	4	4.5	11	130	160	110	358	12	429	14	5	16.3
80/B5	4	5	13	165	200	130	373	12	444	19	6	21.8

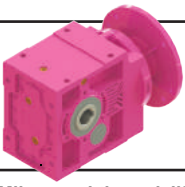

# Ölçü Sayfaları

## Dimension Pages

### Abmessungsseiten

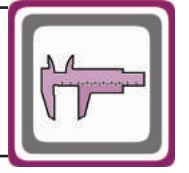

-Mil ucu çekirme deliği DIN 332 sayfa 2 / Tapped center hole to DIN 332, sheet 2 / Zentrierung mit gewinde DIN 332, Blatt 2

KN275.04  
KN276.04

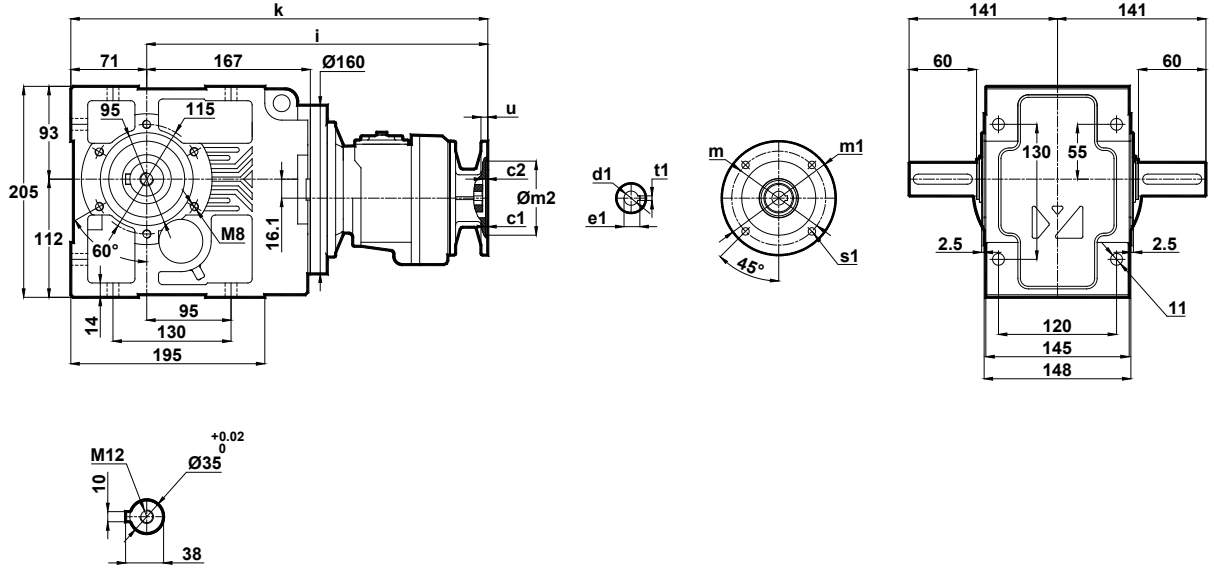

	c1	c2	s1	m	m1	m2	i	u	k	d1	t1	e1
63/B5	3.5	5	10	115	140	95	356	10	427	11	4	12.8
71/B5	4	4.5	11	130	160	110	358	12	429	14	5	16.3
80/B5	4	5	13	165	200	130	373	12	444	19	6	21.8

KN275.05  
KN276.05

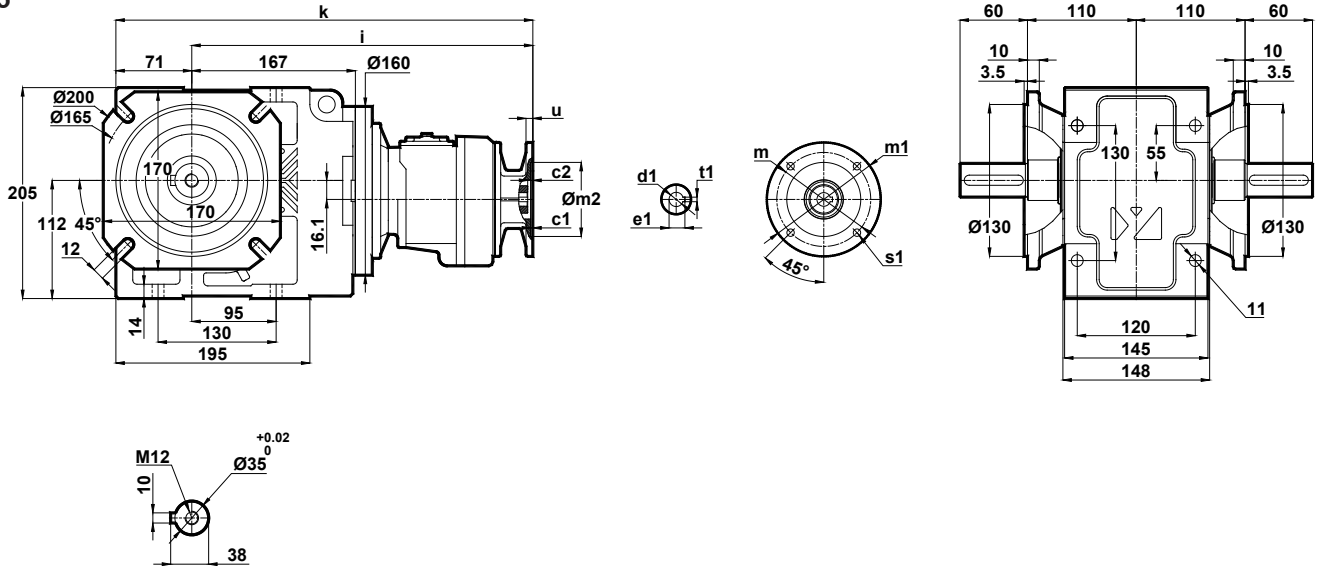

	c1	c2	s1	m	m1	m2	i	u	k	d1	t1	e1
63/B5	3.5	5	10	115	140	95	356	10	427	11	4	12.8
71/B5	4	4.5	11	130	160	110	358	12	429	14	5	16.3
80/B5	4	5	13	165	200	130	373	12	444	19	6	21.8

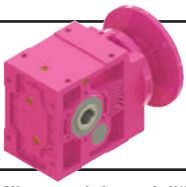

# Ölçü Sayfaları Dimension Pages Abmessungenseiten

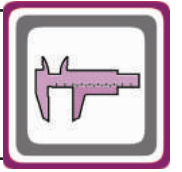

-Mil ucu çektirme deliği DIN 332 sayfa 2 / Tapped center hole to DIN 332, sheet 2 / Zentrierung mit gewinde DIN 332, Blatt 2

KN275.08  
KN276.08

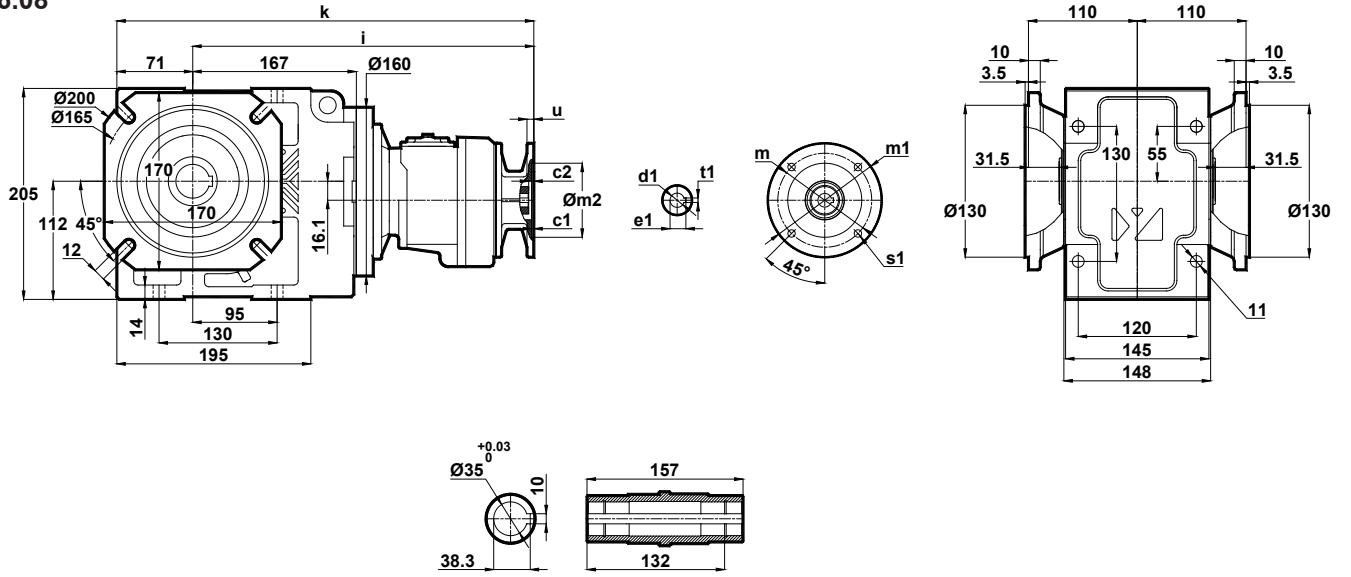

	c1	c2	s1	m	m1	m2	i	u	k	d1	t1	e1
63/B5	3.5	5	10	115	140	95	356	10	427	11	4	12.8
71/B5	4	4.5	11	130	160	110	358	12	429	14	5	16.3
80/B5	4	5	13	165	200	130	373	12	444	19	6	21.8

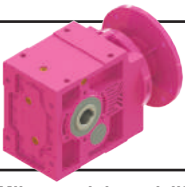

# Ölçü Sayfaları Dimension Pages Abmessungsseiten

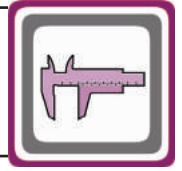

-Mil ucu çekirme deliği DIN 332 sayfa 2 / Tapped center hole to DIN 332, sheet 2 / Zentrierung mit gewinde DIN 332, Blatt 2

## KN373.00

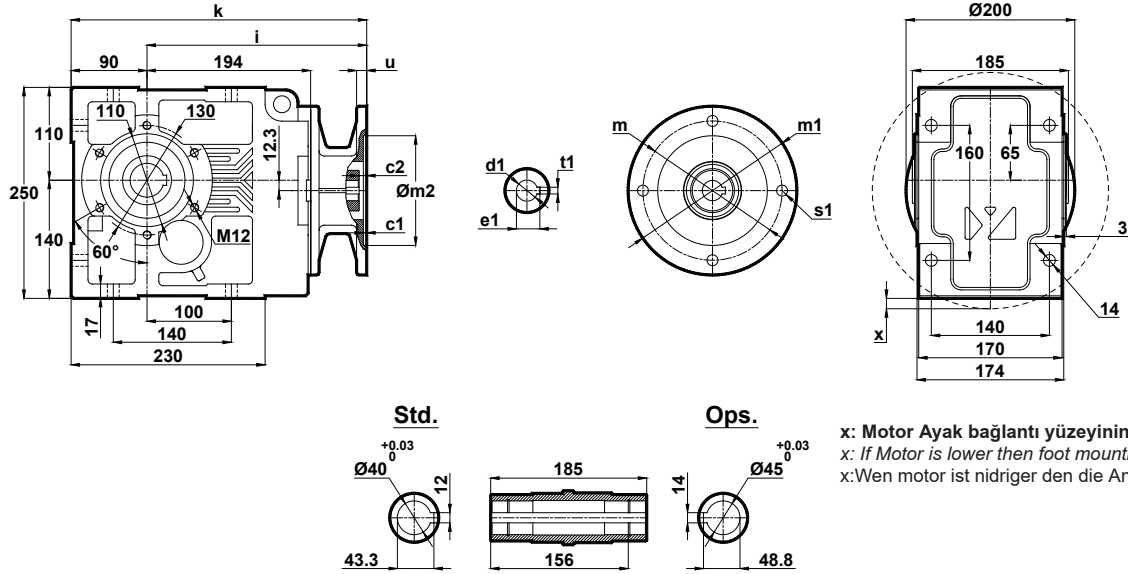

	c1	c2	s1	m	m1	m2	i	u	k	d1	t1	e1	x
71/B5	4	9	11	130	160	110	261	12	351	14	5	16.3	-
80/B5	4	9	13	165	200	130	261	12	351	19	6	21.8	-
90/B5	4	9	13	165	200	130	261	12	351	24	8	27.3	-
100/B5	4.5	9	15	215	250	180	278	15	368	28	8	31.3	-
112/B5	4.5	9	15	215	250	180	278	15	368	28	8	31.3	-
132/B5	4.5	7	15	265	300	230	298	15	388	38	10	41.3	22.3

## KN373.01

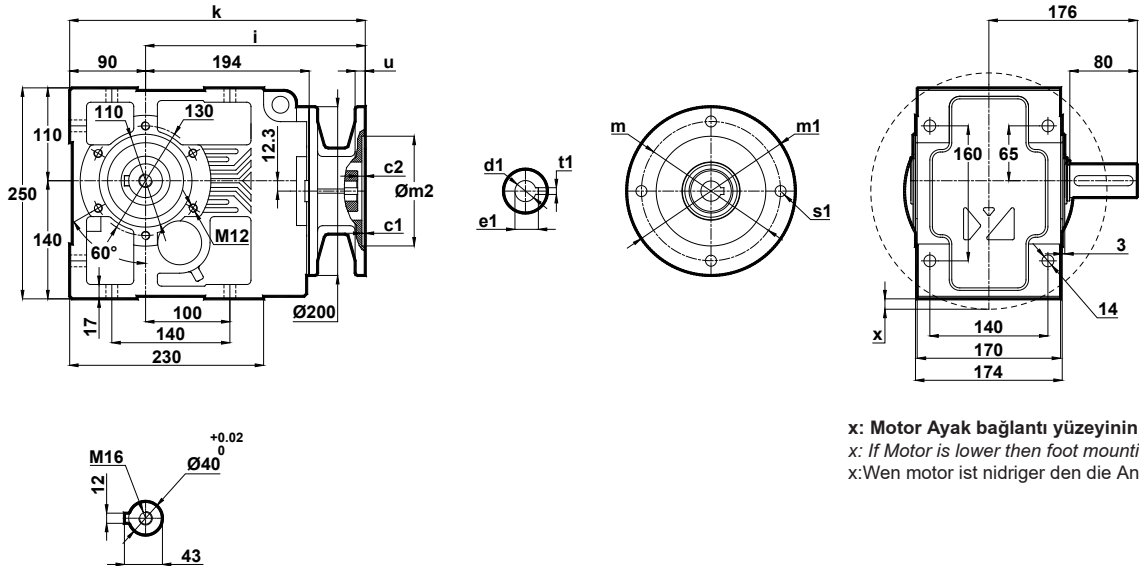

	c1	c2	s1	m	m1	m2	i	u	k	d1	t1	e1	x
71/B5	4	9	11	130	160	110	261	12	351	14	5	16.3	-
80/B5	4	9	13	165	200	130	261	12	351	19	6	21.8	-
90/B5	4	9	13	165	200	130	261	12	351	24	8	27.3	-
100/B5	4.5	9	15	215	250	180	278	15	368	28	8	31.3	-
112/B5	4.5	9	15	215	250	180	278	15	368	28	8	31.3	-
132/B5	4.5	7	15	265	300	230	298	15	388	38	10	41.3	22.3

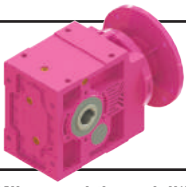

# Ölçü Sayfaları

## Dimension Pages

### Abmessungsseiten

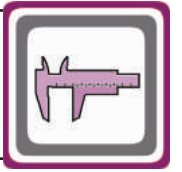

-Mil ucu çektirme deliği DIN 332 sayfa 2 / Tapped center hole to DIN 332, sheet 2 / Zentrierung mit gewinde DIN 332, Blatt 2

#### KN373.02

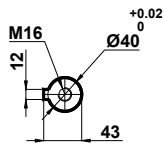
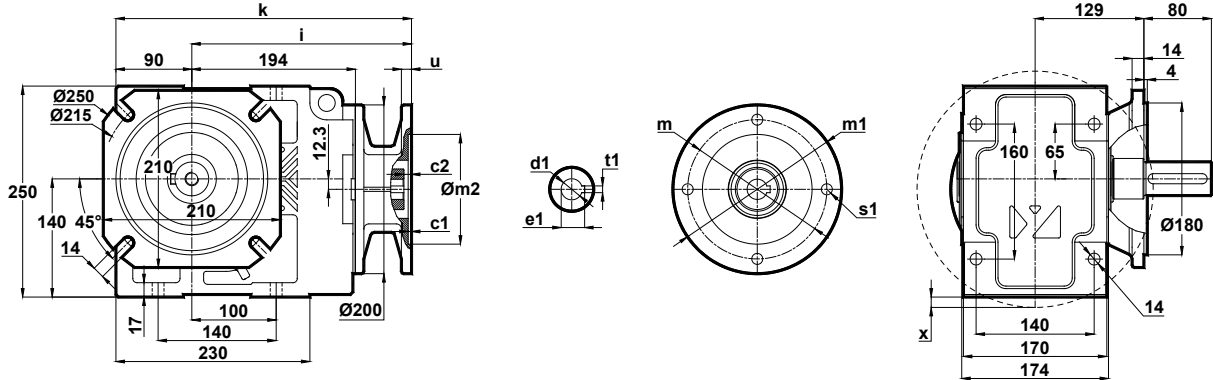

x: Motor Ayak bağlantı yüzeyinin altında ise  
x: If Motor is lower then foot mounting plane  
x: Wenn motor ist niedriger den die Anschlußplatte

	c1	c2	s1	m	m1	m2	i	u	k	d1	t1	e1	x
71/B5	4	9	11	130	160	110	261	12	351	14	5	16.3	-
80/B5	4	9	13	165	200	130	261	12	351	19	6	21.8	-
90/B5	4	9	13	165	200	130	261	12	351	24	8	27.3	-
100/B5	4.5	9	15	215	250	180	278	15	368	28	8	31.3	-
112/B5	4.5	9	15	215	250	180	278	15	368	28	8	31.3	-
132/B5	4.5	7	15	265	300	230	298	15	388	38	10	41.3	22.3

#### KN373.03

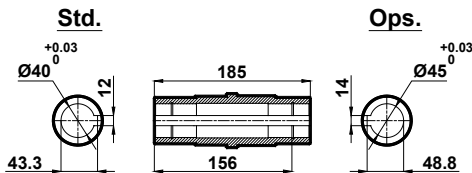
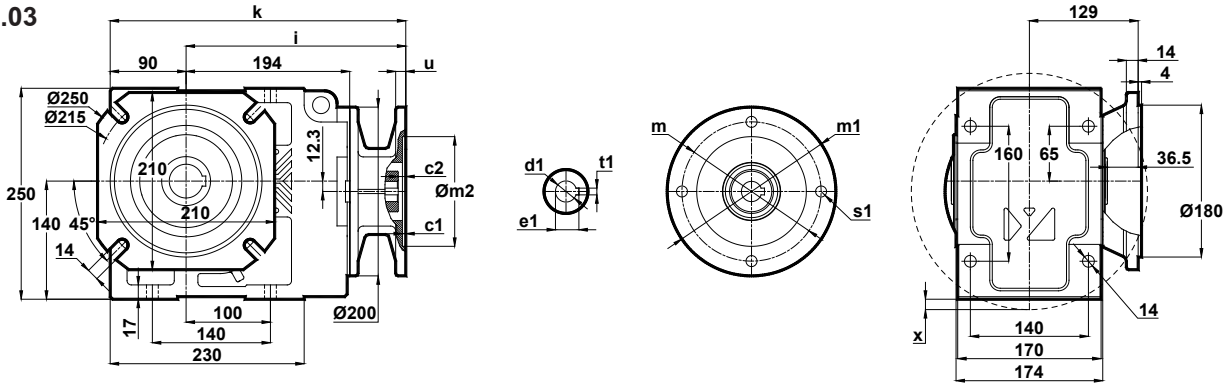

x: Motor Ayak bağlantı yüzeyinin altında ise  
x: If Motor is lower then foot mounting plane  
x: Wenn motor ist niedriger den die Anschlußplatte

	c1	c2	s1	m	m1	m2	i	u	k	d1	t1	e1	x
71/B5	4	9	11	130	160	110	261	12	351	14	5	16.3	-
80/B5	4	9	13	165	200	130	261	12	351	19	6	21.8	-
90/B5	4	9	13	165	200	130	261	12	351	24	8	27.3	-
100/B5	4.5	9	15	215	250	180	278	15	368	28	8	31.3	-
112/B5	4.5	9	15	215	250	180	278	15	368	28	8	31.3	-
132/B5	4.5	7	15	265	300	230	298	15	388	38	10	41.3	22.3

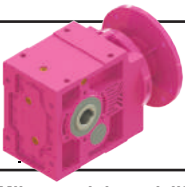

# Ölçü Sayfaları

## Dimension Pages

### Abmessungsseiten

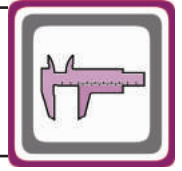

-Mil ucu çekirme deliği DIN 332 sayfa 2 / Tapped center hole to DIN 332, sheet 2 / Zentrierung mit gewinde DIN 332, Blatt 2

#### KN373.04

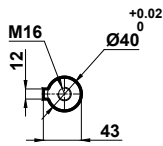
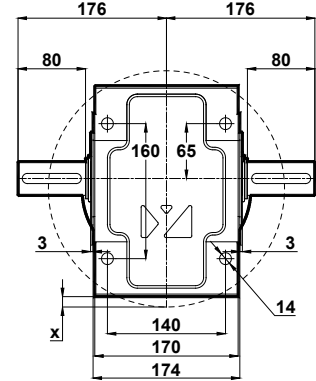
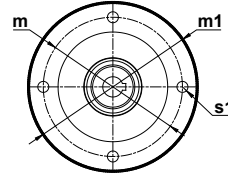
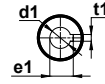
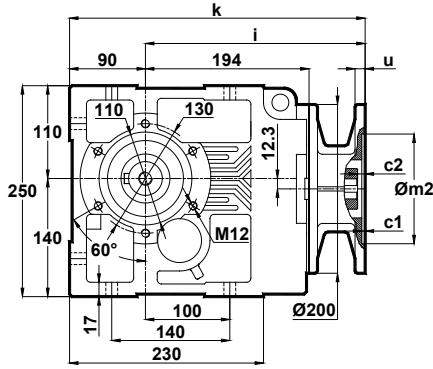

x: Motor ayak bağlantı yüzeyinin altında ise  
x: If Motor is lower then foot mounting plane  
x:Wen motor ist nidriger den die Anschlußplatte

	c1	c2	s1	m	m1	m2	i	u	k	d1	t1	e1	x
71/B5	4	9	11	130	160	110	261	12	351	14	5	16.3	-
80/B5	4	9	13	165	200	130	261	12	351	19	6	21.8	-
90/B5	4	9	13	165	200	130	261	12	351	24	8	27.3	-
100/B5	4.5	9	15	215	250	180	278	15	368	28	8	31.3	-
112/B5	4.5	9	15	215	250	180	278	15	368	28	8	31.3	-
132/B5	4.5	7	15	265	300	230	298	15	388	38	10	41.3	22.3

#### KN373.05

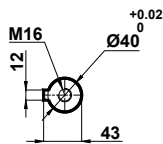
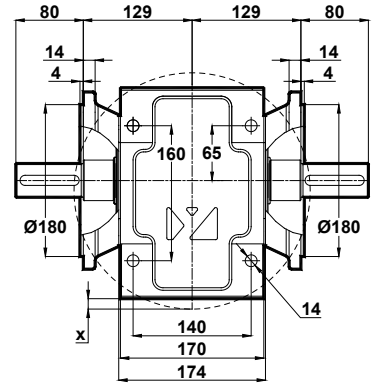
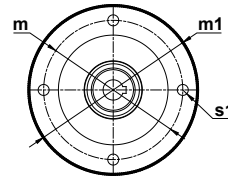
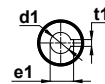
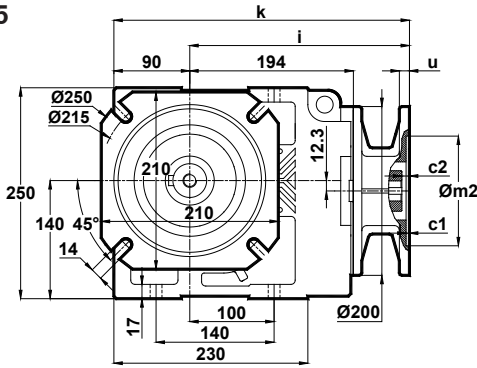

x: Motor ayak bağlantı yüzeyinin altında ise  
x: If Motor is lower then foot mounting plane  
x:Wen motor ist nidriger den die Anschlußplatte

	c1	c2	s1	m	m1	m2	i	u	k	d1	t1	e1	x
71/B5	4	9	11	130	160	110	261	12	351	14	5	16.3	-
80/B5	4	9	13	165	200	130	261	12	351	19	6	21.8	-
90/B5	4	9	13	165	200	130	261	12	351	24	8	27.3	-
100/B5	4.5	9	15	215	250	180	278	15	368	28	8	31.3	-
112/B5	4.5	9	15	215	250	180	278	15	368	28	8	31.3	-
132/B5	4.5	7	15	265	300	230	298	15	388	38	10	41.3	22.3

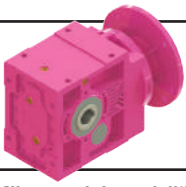

# Ölçü Sayfaları Dimension Pages Abmessungsseiten

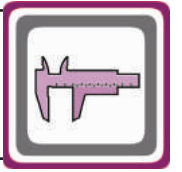

-Mil ucu çekirme deliği DIN 332 sayfa 2 / Tapped center hole to DIN 332, sheet 2 / Zentrierung mit gewinde DIN 332, Blatt 2

KN373.08

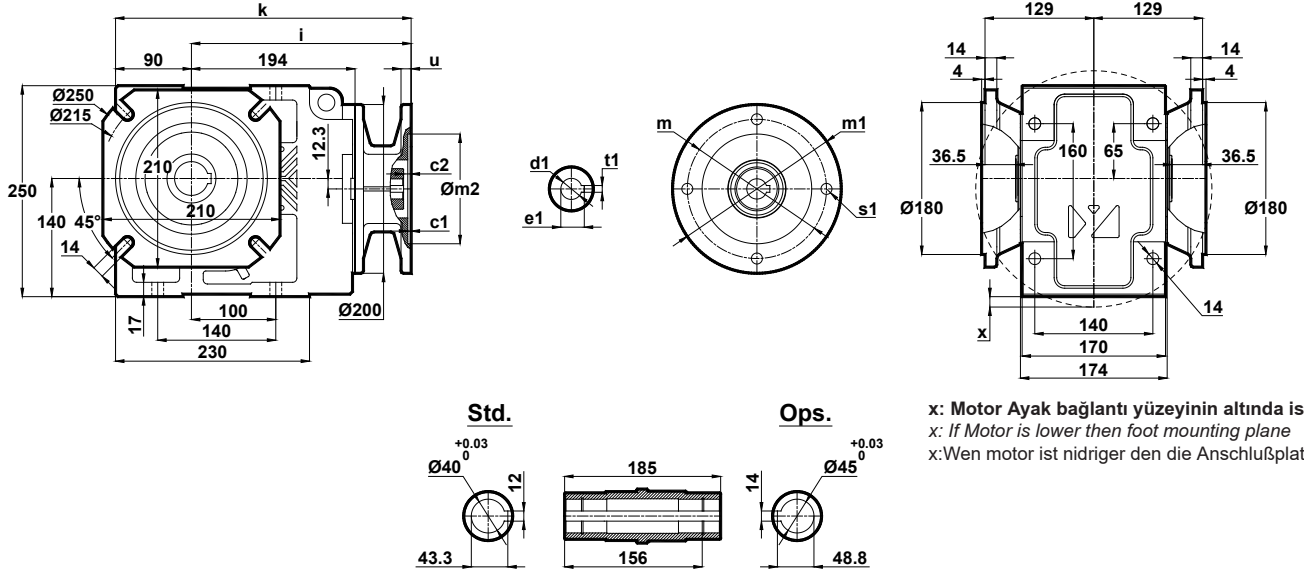

	c1	c2	s1	m	m1	m2	i	u	k	d1	t1	e1	x
71/B5	4	9	11	130	160	110	261	12	351	14	5	16.3	-
80/B5	4	9	13	165	200	130	261	12	351	19	6	21.8	-
90/B5	4	9	13	165	200	130	261	12	351	24	8	27.3	-
100/B5	4.5	9	15	215	250	180	278	15	368	28	8	31.3	-
112/B5	4.5	9	15	215	250	180	278	15	368	28	8	31.3	-
132/B5	4.5	7	15	265	300	230	298	15	388	38	10	41.3	22.3

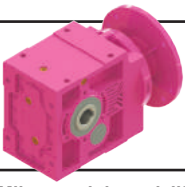

# Ölçü Sayfaları

## Dimension Pages

### Abmessungsseiten

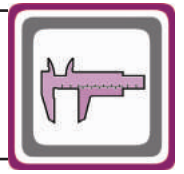

-Mil ucu çektirme deliği DIN 332 sayfa 2 / Tapped center hole to DIN 332, sheet 2 / Zentrierung mit gewinde DIN 332, Blatt 2

#### KN374.00

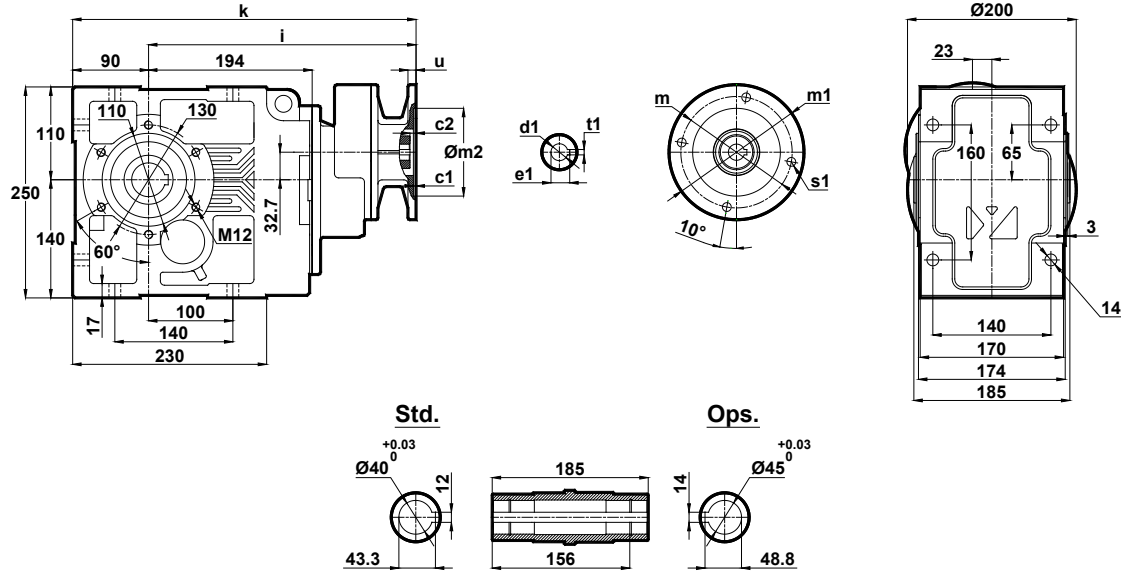

	c1	c2	s1	m	m1	m2	i	u	k	d1	t1	e1
63/B5	4	8	9	115	140	95	338	12	428	11	4	12.8
71/B5	4	8.5	11	130	160	110	309	12	399	14	5	16.3
80/B5	4	5	13	165	200	130	338	12	428	19	6	21.8

#### KN374.01

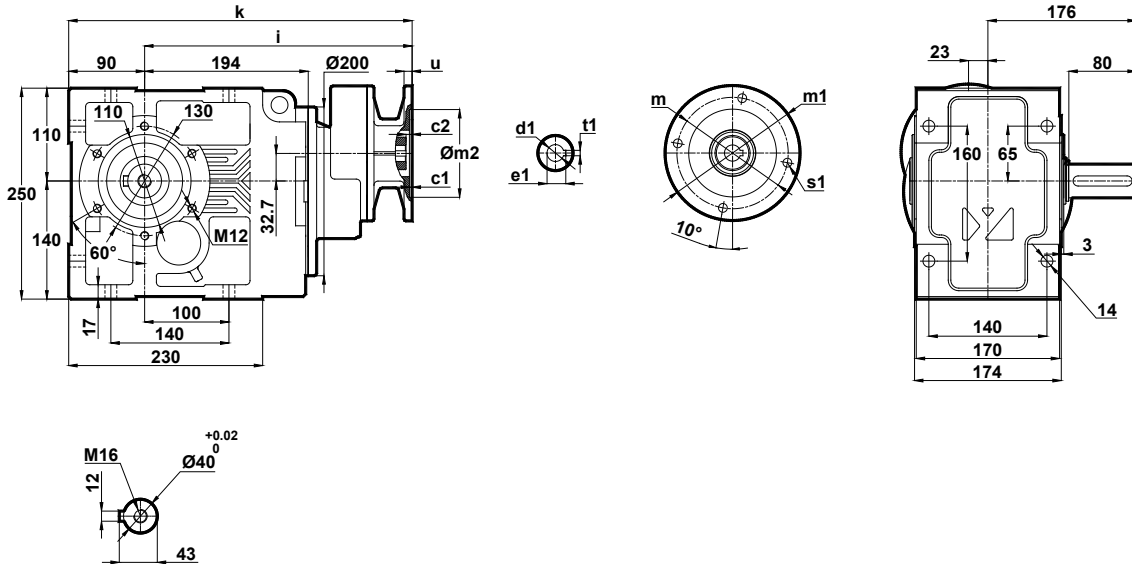

	c1	c2	s1	m	m1	m2	i	u	k	d1	t1	e1
63/B5	4	8	9	115	140	95	338	12	428	11	4	12.8
71/B5	4	8.5	11	130	160	110	309	12	399	14	5	16.3
80/B5	4	5	13	165	200	130	338	12	428	19	6	21.8

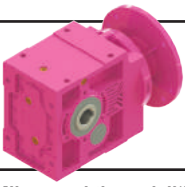

# Ölçü Sayfaları Dimension Pages Abmessungenseiten

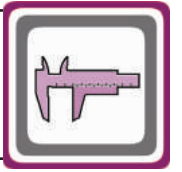

-Mil ucu çekirme deliği DIN 332 sayfa 2 / Tapped center hole to DIN 332, sheet 2 / Zentrierung mit gewinde DIN 332, Blatt 2

## KN374.02

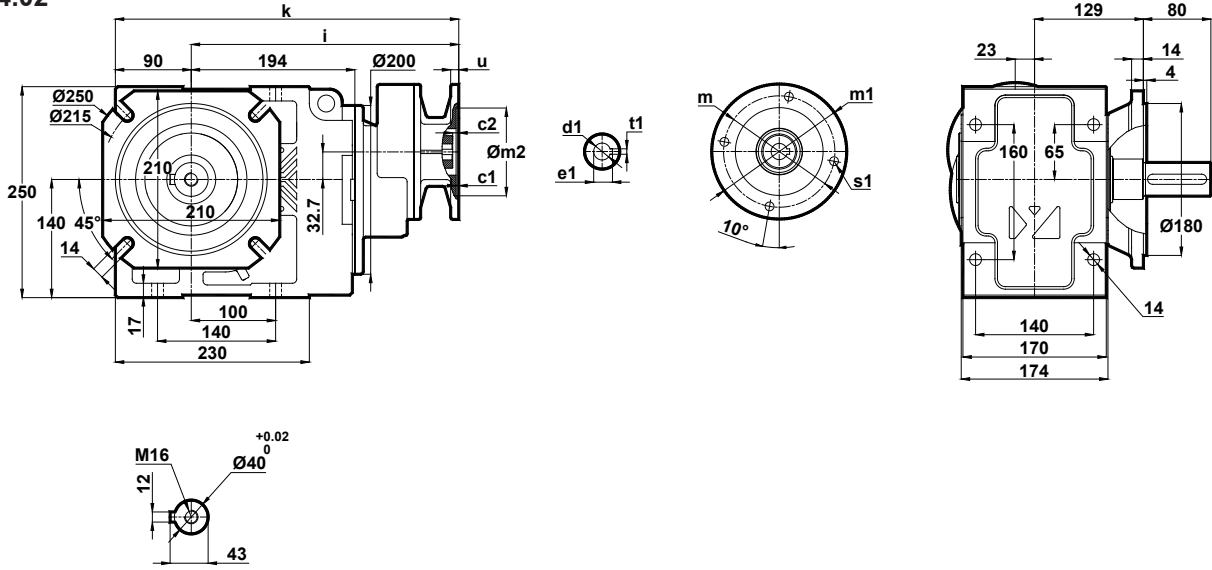

	c1	c2	s1	m	m1	m2	i	u	k	d1	t1	e1
63/B5	4	8	9	115	140	95	338	12	428	11	4	12.8
71/B5	4	8.5	11	130	160	110	309	12	399	14	5	16.3
80/B5	4	5	13	165	200	130	338	12	428	19	6	21.8

## KN374.03

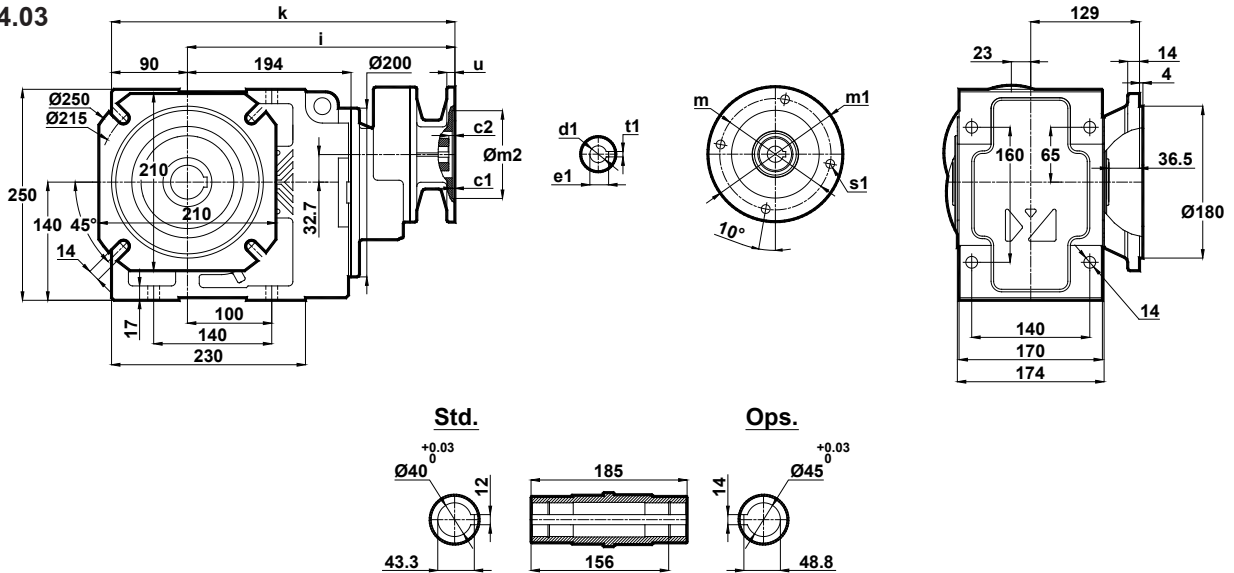

	c1	c2	s1	m	m1	m2	i	u	k	d1	t1	e1
63/B5	4	8	9	115	140	95	338	12	428	11	4	12.8
71/B5	4	8.5	11	130	160	110	309	12	399	14	5	16.3
80/B5	4	5	13	165	200	130	338	12	428	19	6	21.8

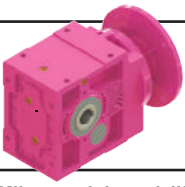

# Ölçü Sayfaları

## Dimension Pages

### Abmessungsseiten

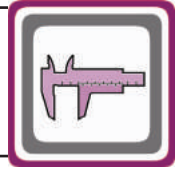

-Mil ucu çekirme deliği DIN 332 sayfa 2 / Tapped center hole to DIN 332, sheet 2 / Zentrierung mit gewinde DIN 332, Blatt 2

#### KN374.04

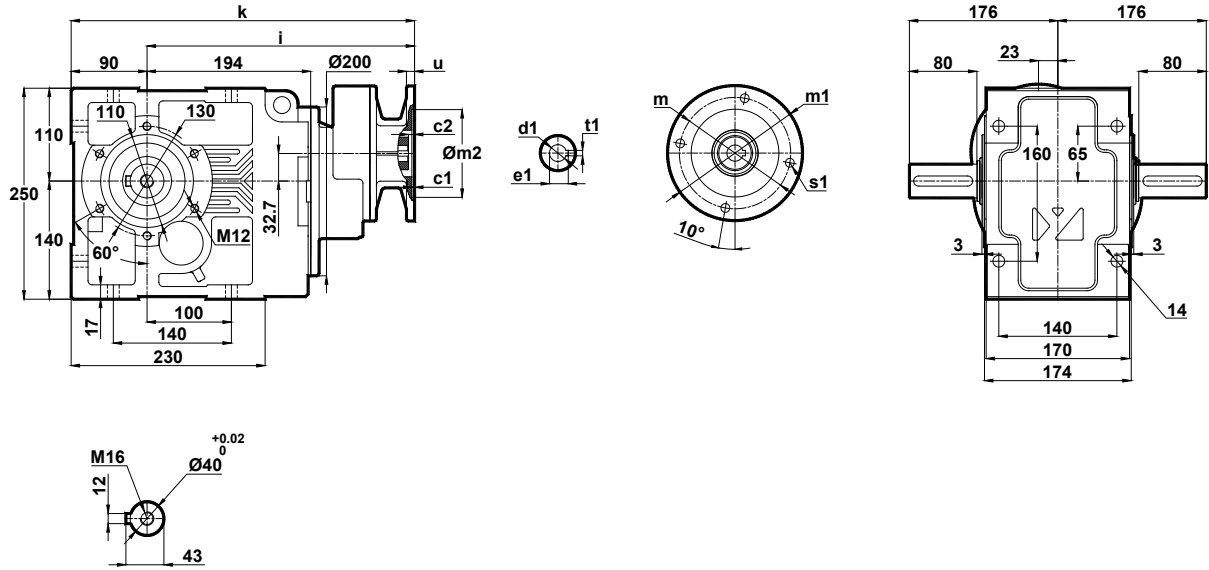

	c1	c2	s1	m	m1	m2	i	u	k	d1	t1	e1
63/B5	4	8	9	115	140	95	338	12	428	11	4	12.8
71/B5	4	8.5	11	130	160	110	309	12	399	14	5	16.3
80/B5	4	5	13	165	200	130	338	12	428	19	6	21.8

#### KN374.05

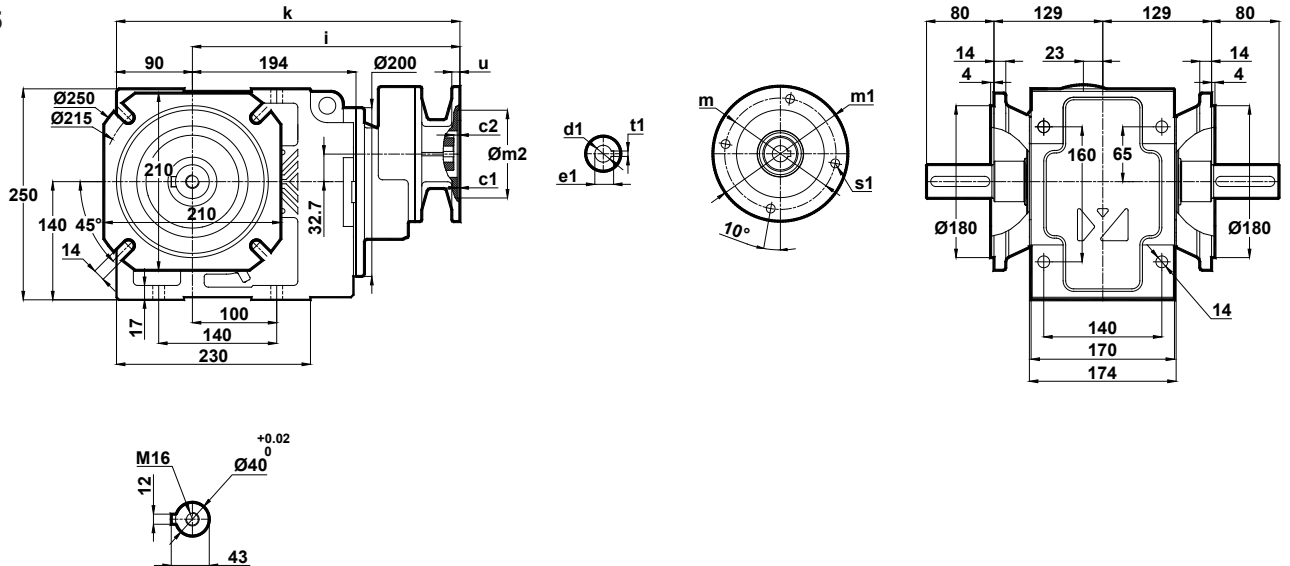

	c1	c2	s1	m	m1	m2	i	u	k	d1	t1	e1
63/B5	4	8	9	115	140	95	338	12	428	11	4	12.8
71/B5	4	8.5	11	130	160	110	309	12	399	14	5	16.3
80/B5	4	5	13	165	200	130	338	12	428	19	6	21.8

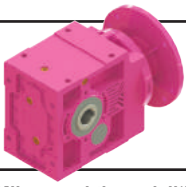

# Ölçü Sayfaları Dimension Pages Abmessungenseiten

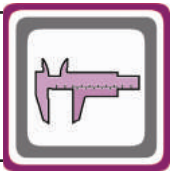

-Mil ucu çektirme deliği DIN 332 sayfa 2 / Tapped center hole to DIN 332, sheet 2 / Zentrierung mit gewinde DIN 332, Blatt 2

KN374.08

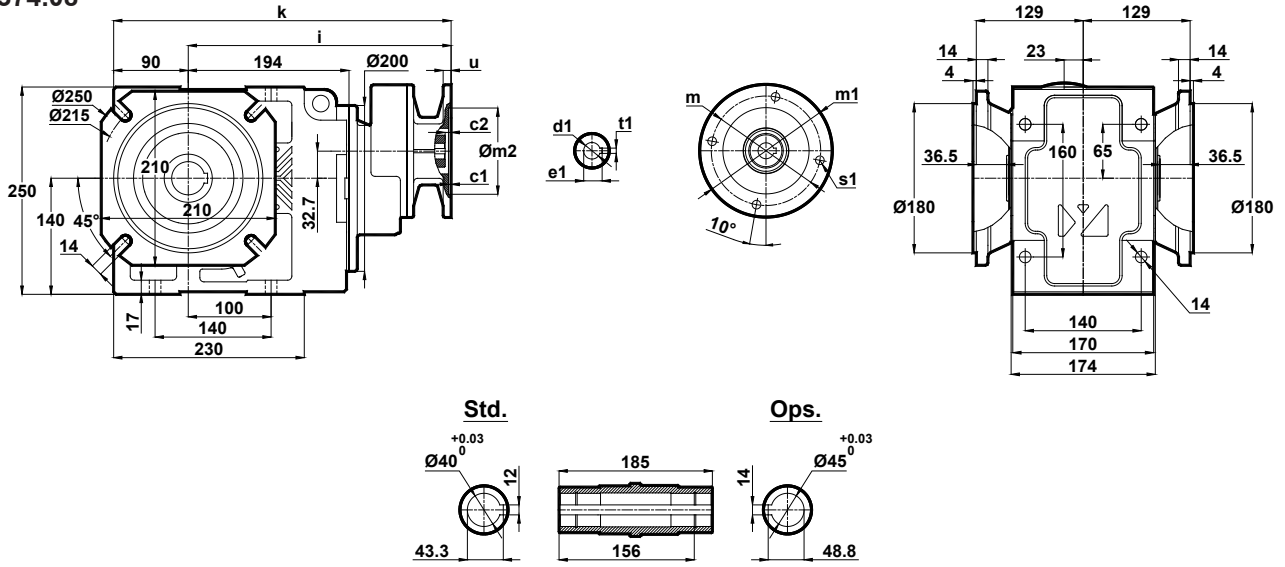

	c1	c2	s1	m	m1	m2	i	u	k	d1	t1	e1
63/B5	4	8	9	115	140	95	338	12	428	11	4	12.8
71/B5	4	8.5	11	130	160	110	309	12	399	14	5	16.3
80/B5	4	5	13	165	200	130	338	12	428	19	6	21.8

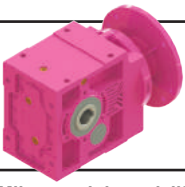

# Ölçü Sayfaları

## Dimension Pages

## Abmessungsseiten

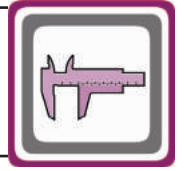

-Mil ucu çekirme deliği DIN 332 sayfa 2 / Tapped center hole to DIN 332, sheet 2 / Zentrierung mit gewinde DIN 332, Blatt 2

KN375.00  
KN376.00

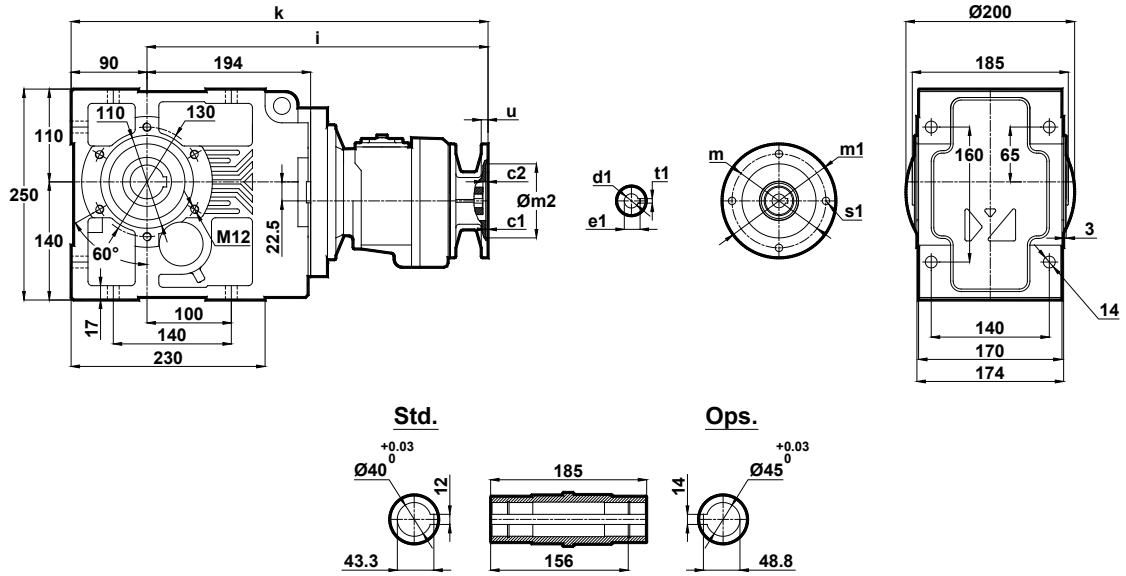

	c1	c2	s1	m	m1	m2	i	u	k	d1	t1	e1
63/B5	3.5	5	10	115	140	95	405	10	495	11	4	12.8
71/B5	4	4.5	11	130	160	110	405	12	495	14	5	16.3

KN375.01  
KN376.01

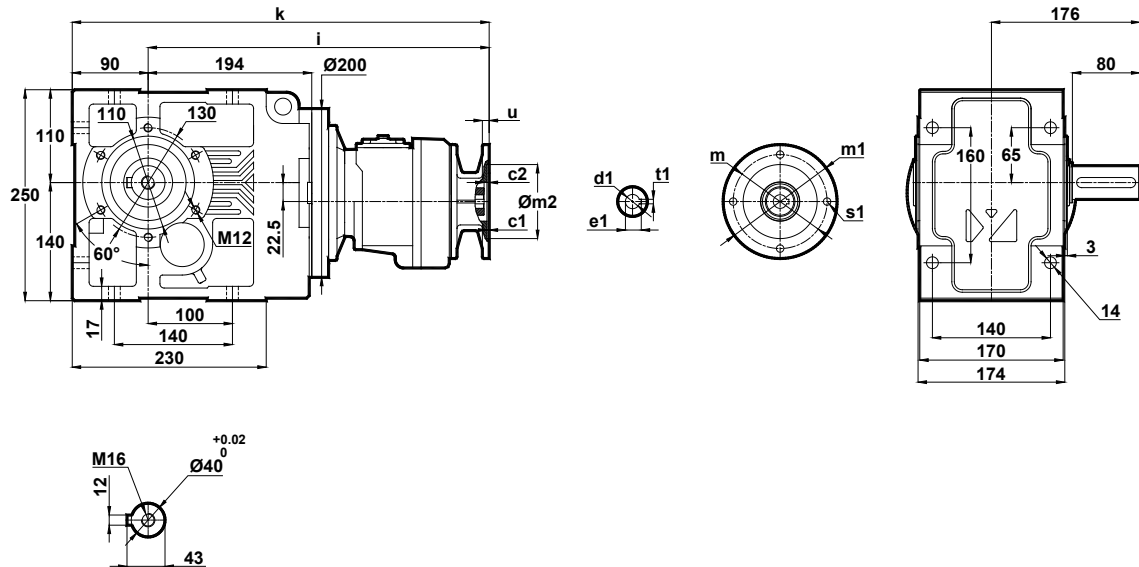

	c1	c2	s1	m	m1	m2	i	u	k	d1	t1	e1
63/B5	3.5	5	10	115	140	95	405	10	495	11	4	12.8
71/B5	4	4.5	11	130	160	110	405	12	495	14	5	16.3

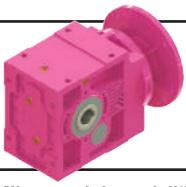

# Ölçü Sayfaları

## Dimension Pages

### Abmessungsseiten

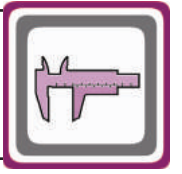

-Mil ucu çekirme deliği DIN 332 sayfa 2 / Tapped center hole to DIN 332, sheet 2 / Zentrierung mit gewinde DIN 332, Blatt 2

KN375.02  
KN376.02

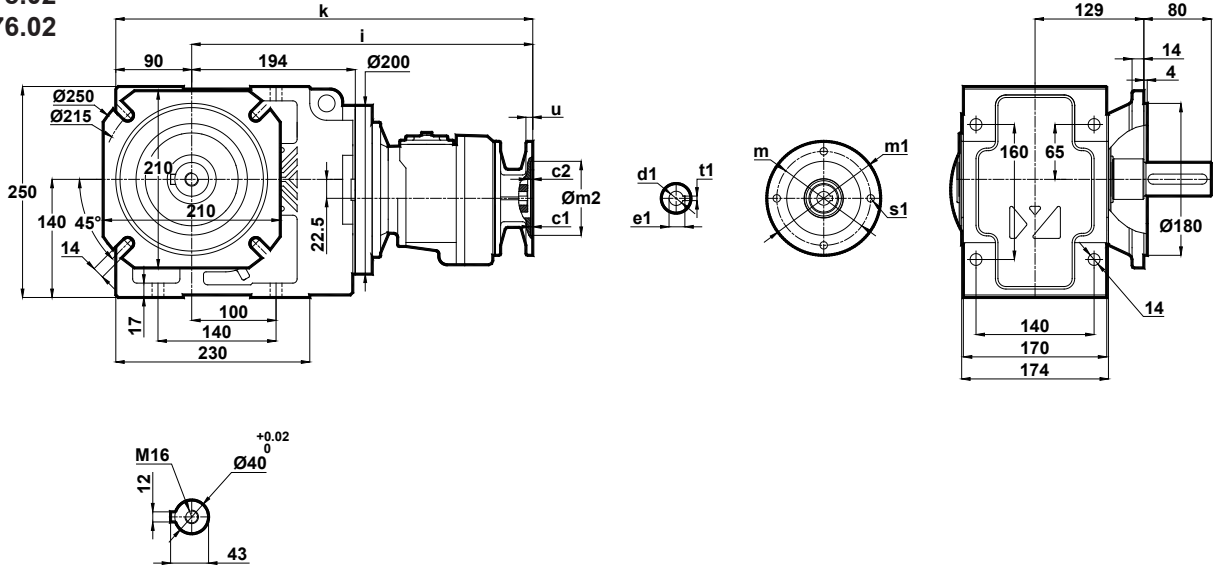

	c1	c2	s1	m	m1	m2	i	u	k	d1	t1	e1
63/B5	3.5	5	10	115	140	95	405	10	495	11	4	12.8
71/B5	4	4.5	11	130	160	110	405	12	495	14	5	16.3

KN375.03  
KN376.03

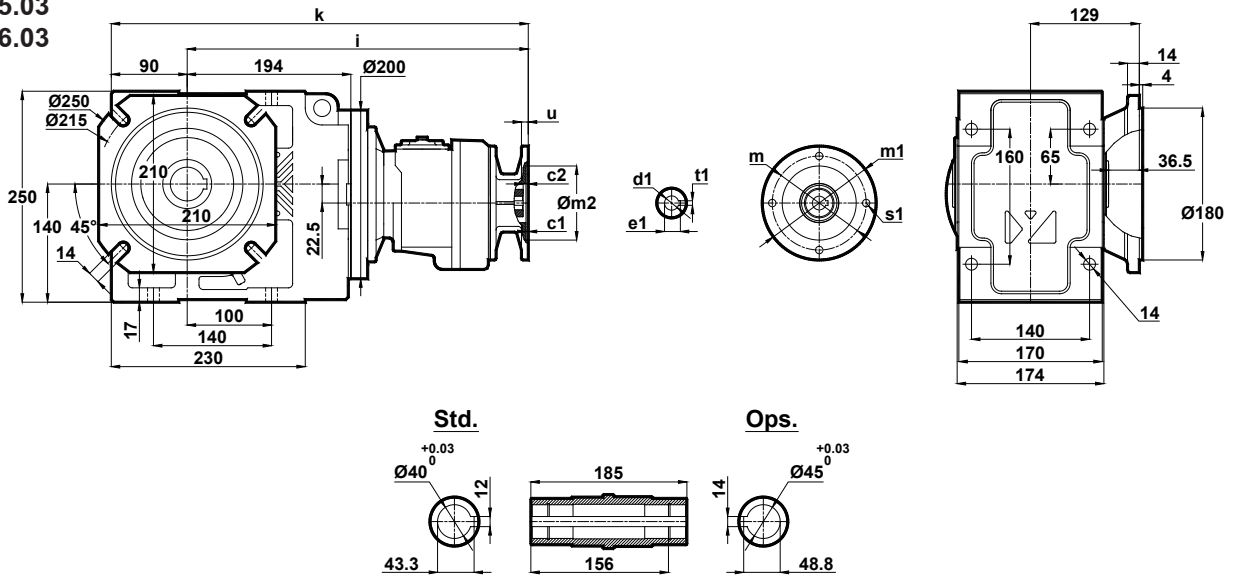

	c1	c2	s1	m	m1	m2	i	u	k	d1	t1	e1
63/B5	3.5	5	10	115	140	95	405	10	495	11	4	12.8
71/B5	4	4.5	11	130	160	110	405	12	495	14	5	16.3

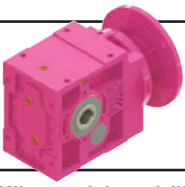

# Ölçü Sayfaları

## Dimension Pages

### Abmessungsseiten

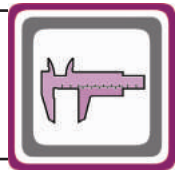

-Mil ucu çekirme deliği DIN 332 sayfa 2 / Tapped center hole to DIN 332, sheet 2 / Zentrierung mit gewinde DIN 332, Blatt 2

KN375.04  
KN376.04

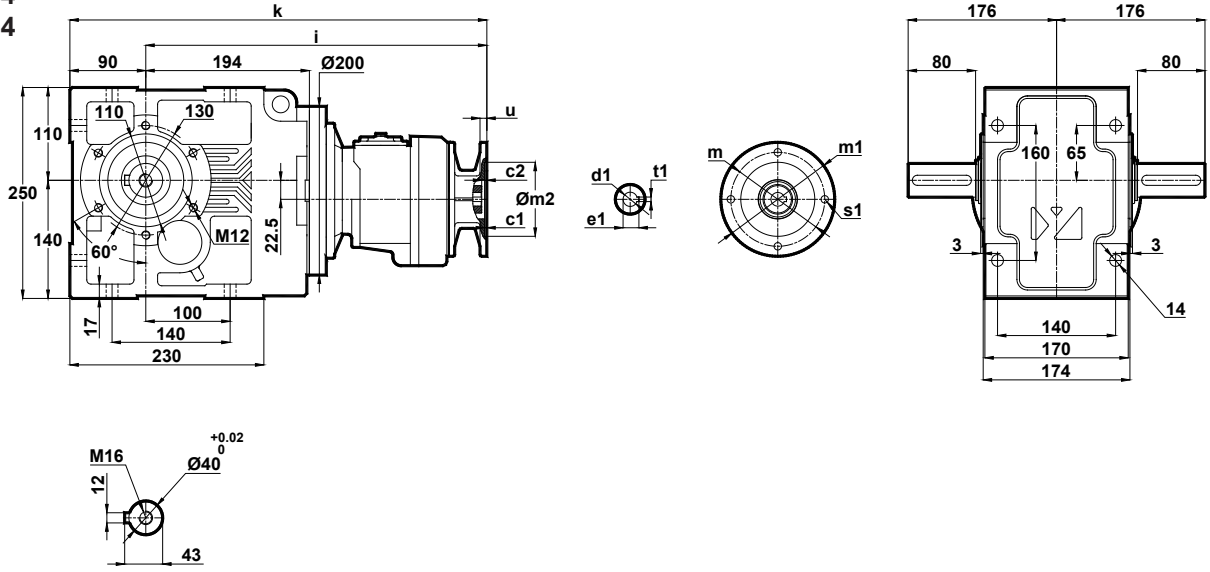

	c1	c2	s1	m	m1	m2	i	u	k	d1	t1	e1
63/B5	3.5	5	10	115	140	95	405	10	495	11	4	12.8
71/B5	4	4.5	11	130	160	110	405	12	495	14	5	16.3

KN375.05  
KN376.05

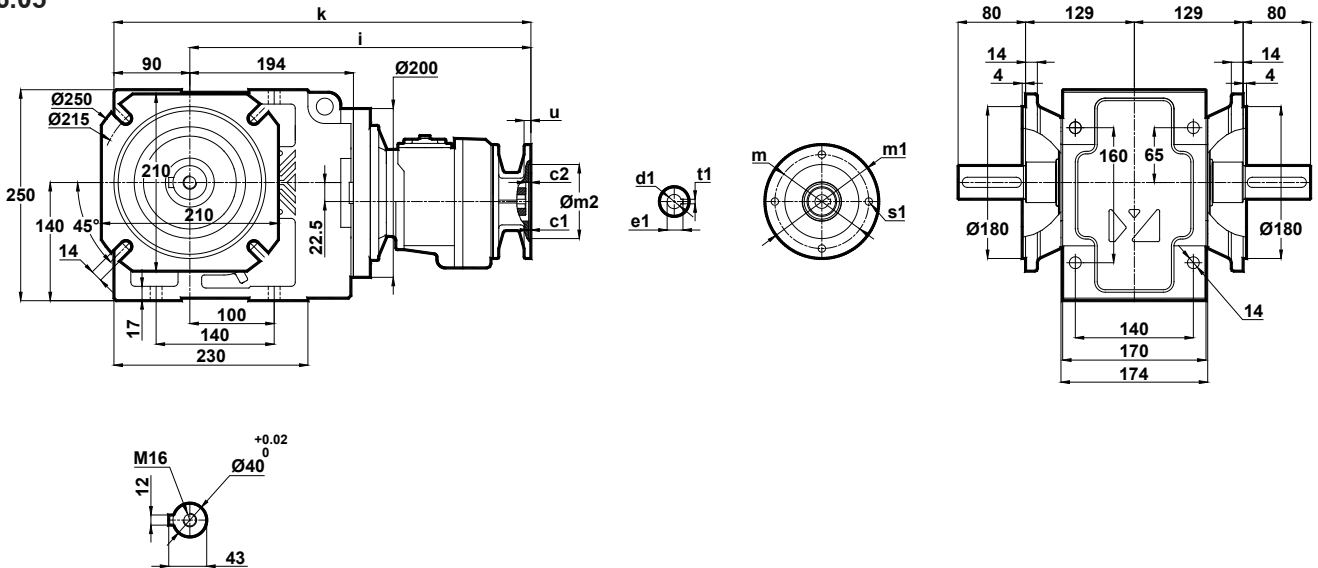

	c1	c2	s1	m	m1	m2	i	u	k	d1	t1	e1
63/B5	3.5	5	10	115	140	95	405	10	495	11	4	12.8
71/B5	4	4.5	11	130	160	110	405	12	495	14	5	16.3

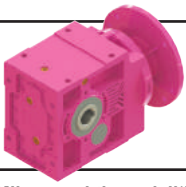

# Ölçü Sayfaları Dimension Pages Abmessungenseiten

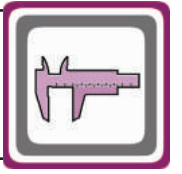

-Mil ucu çekirme deliği DIN 332 sayfa 2 / Tapped center hole to DIN 332, sheet 2 / Zentrierung mit gewinde DIN 332, Blatt 2

KN375.08  
KN376.08

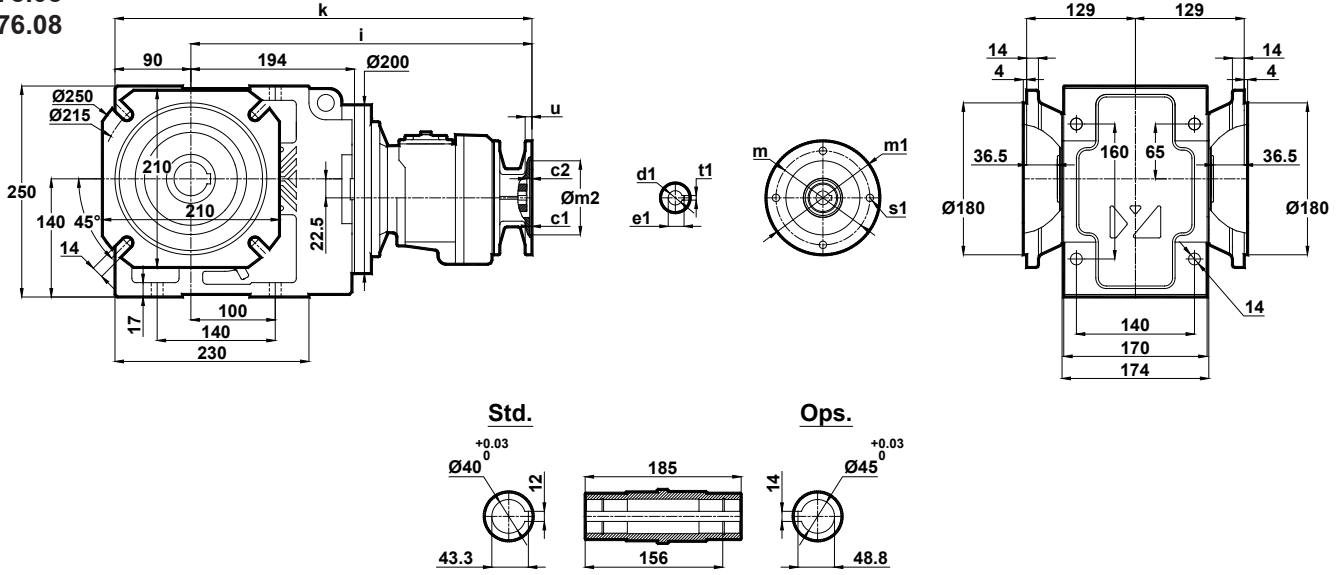

	c1	c2	s1	m	m1	m2	i	u	k	d1	t1	e1
63/B5	3.5	5	10	115	140	95	405	10	495	11	4	12.8
71/B5	4	4.5	11	130	160	110	405	12	495	14	5	16.3

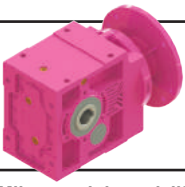

# Ölçü Sayfaları Dimension Pages Abmessungsseiten



-Mil ucu çekirme deliği DIN 332 sayfa 2 / Tapped center hole to DIN 332, sheet 2 / Zentrierung mit gewinde DIN 332, Blatt 2

## KN473.00

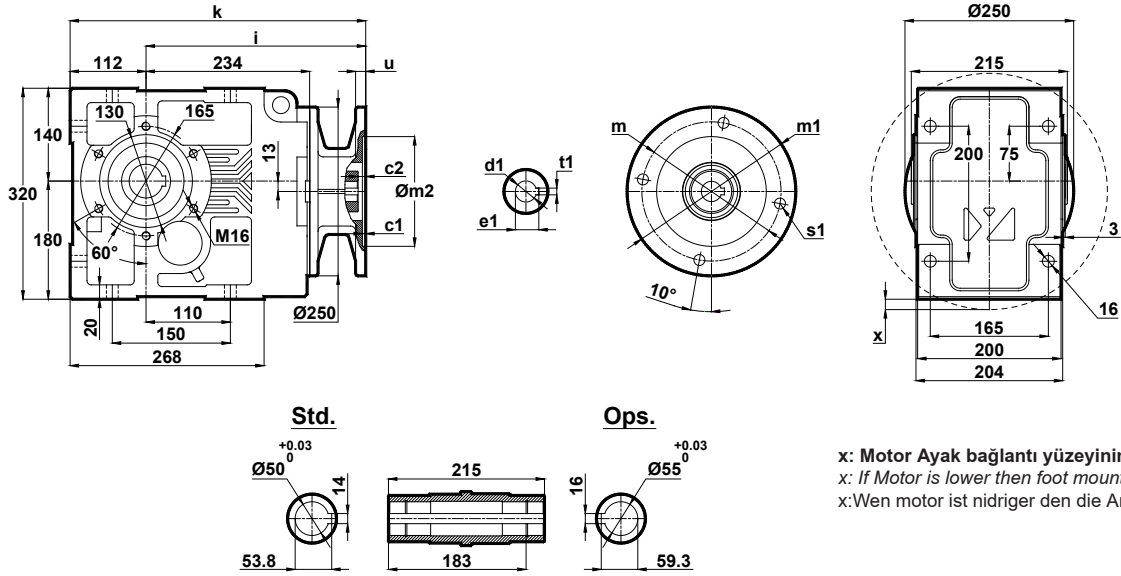

x: Motor Ayak bağlantı yüzeyinin altında ise  
x: If Motor is lower then foot mounting plane  
x: Wenn motor ist niedriger den die Anschlußplatte

	c1	c2	s1	m	m1	m2	i	u	k	d1	t1	e1	x
80/B5	4	5	12	165	200	130	291	12	403	19	6	21.8	-
90/B5	4	5	13	165	200	130	291	12	403	24	8	27.3	-
100/B5	4.5	9	15	215	250	180	309	15	421	28	8	31.3	-
112/B5	4.5	9	15	215	250	180	309	15	421	28	8	31.3	-
132/B5	4.5	6	15	265	300	230	328	15	440	38	10	41.3	-
160/B5	5.5	10	19	300	350	250	407	20	519	42	12	45.3	8
180/B5	5.5	10	19	300	350	250	407	20	519	48	14	51.8	8

## KN473.01

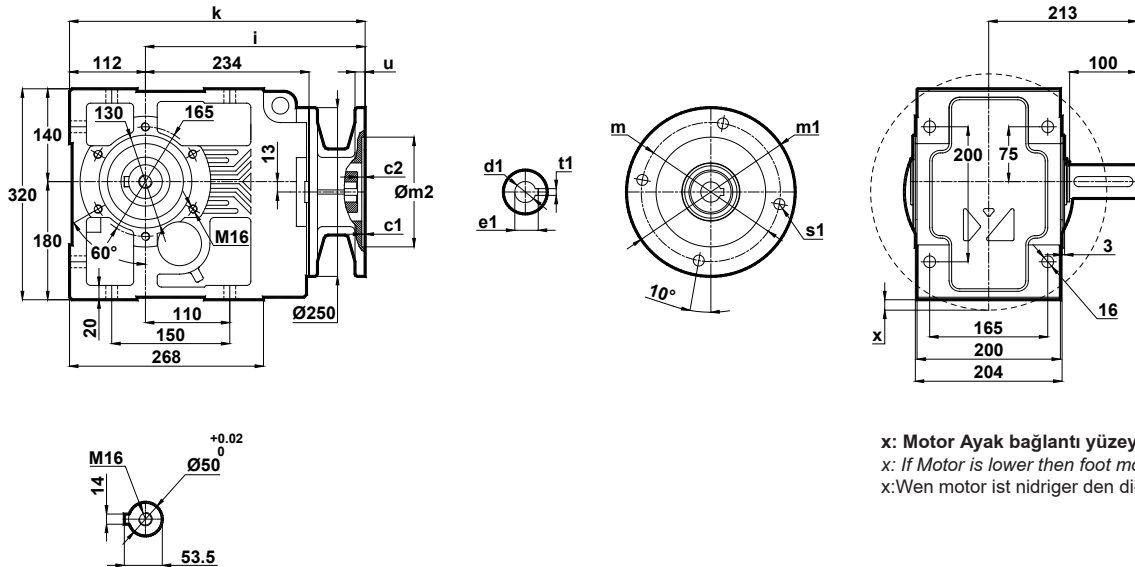

x: Motor Ayak bağlantı yüzeyinin altında ise  
x: If Motor is lower then foot mounting plane  
x: Wenn motor ist niedriger den die Anschlußplatte

	c1	c2	s1	m	m1	m2	i	u	k	d1	t1	e1	x
80/B5	4	5	12	165	200	130	291	12	403	19	6	21.8	-
90/B5	4	5	13	165	200	130	291	12	403	24	8	27.3	-
100/B5	4.5	9	15	215	250	180	309	15	421	28	8	31.3	-
112/B5	4.5	9	15	215	250	180	309	15	421	28	8	31.3	-
132/B5	4.5	6	15	265	300	230	328	15	440	38	10	41.3	-
160/B5	5.5	10	19	300	350	250	407	20	519	42	12	45.3	8
180/B5	5.5	10	19	300	350	250	407	20	519	48	14	51.8	8

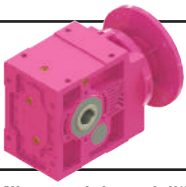

# Ölçü Sayfaları Dimension Pages Abmessungsseiten

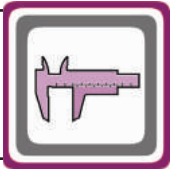

-Mil ucu çektirme deliği DIN 332 sayfa 2 / Tapped center hole to DIN 332, sheet 2 / Zentrierung mit gewinde DIN 332, Blatt 2

## KN473.02

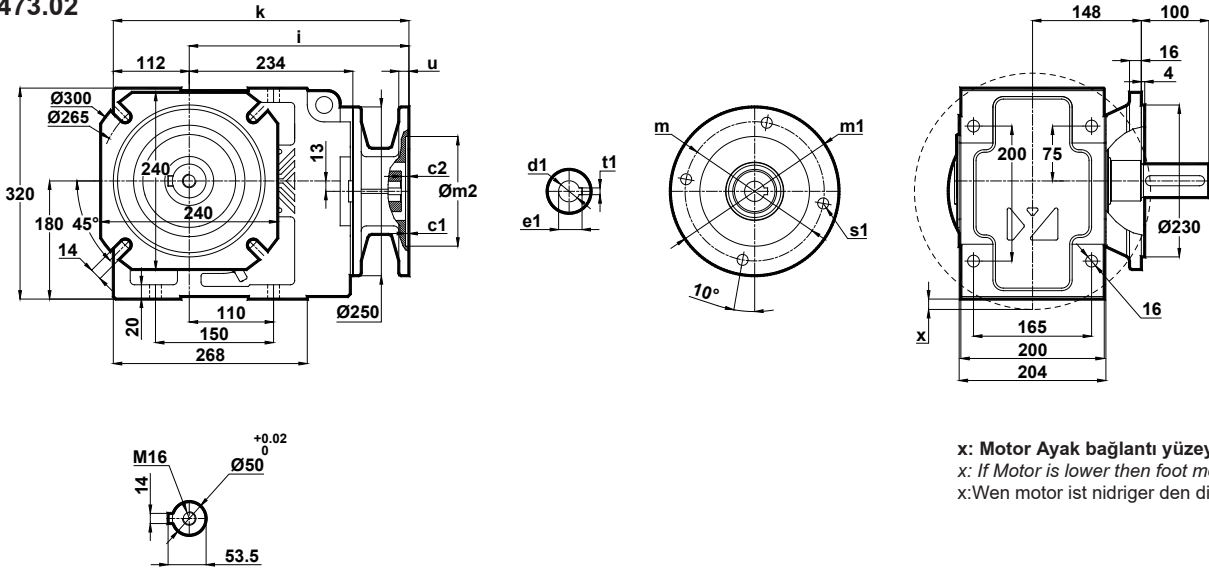

x: Motor Ayak bağlantı yüzeyinin altında ise  
x: If Motor is lower then foot mounting plane  
x: Wenn motor ist niedriger den die Anschlussplatte

	c1	c2	s1	m	m1	m2	i	u	k	d1	t1	e1	x
80/B5	4	5	12	165	200	130	291	12	403	19	6	21.8	-
90/B5	4	5	13	165	200	130	291	12	403	24	8	27.3	-
100/B5	4.5	9	15	215	250	180	309	15	421	28	8	31.3	-
112/B5	4.5	9	15	215	250	180	309	15	421	28	8	31.3	-
132/B5	4.5	6	15	265	300	230	328	15	440	38	10	41.3	-
160/B5	5.5	10	19	300	350	250	407	20	519	42	12	45.3	8
180/B5	5.5	10	19	300	350	250	407	20	519	48	14	51.8	8

## KN473.03

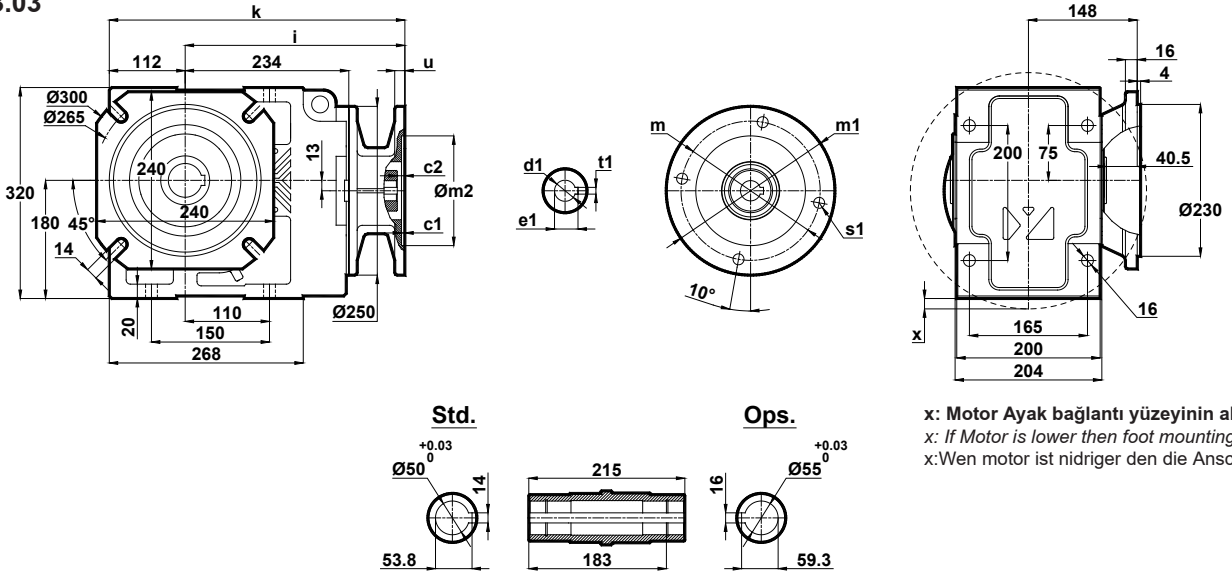

x: Motor Ayak bağlantı yüzeyinin altında ise  
x: If Motor is lower then foot mounting plane  
x: Wenn motor ist niedriger den die Anschlussplatte

	c1	c2	s1	m	m1	m2	i	u	k	d1	t1	e1	x
80/B5	4	5	12	165	200	130	291	12	403	19	6	21.8	-
90/B5	4	5	13	165	200	130	291	12	403	24	8	27.3	-
100/B5	4.5	9	15	215	250	180	309	15	421	28	8	31.3	-
112/B5	4.5	9	15	215	250	180	309	15	421	28	8	31.3	-
132/B5	4.5	6	15	265	300	230	328	15	440	38	10	41.3	-
160/B5	5.5	10	19	300	350	250	407	20	519	42	12	45.3	8
180/B5	5.5	10	19	300	350	250	407	20	519	48	14	51.8	8

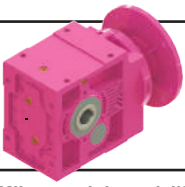

# Ölçü Sayfaları Dimension Pages Abmessungsseiten

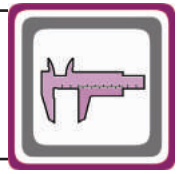

-Mil ucu çekirme deliği DIN 332 sayfa 2 / Tapped center hole to DIN 332, sheet 2 / Zentrierung mit gewinde DIN 332, Blatt 2

## KN473.04

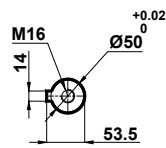
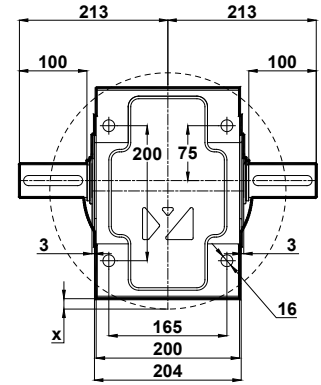
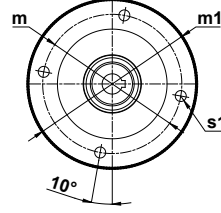
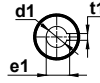
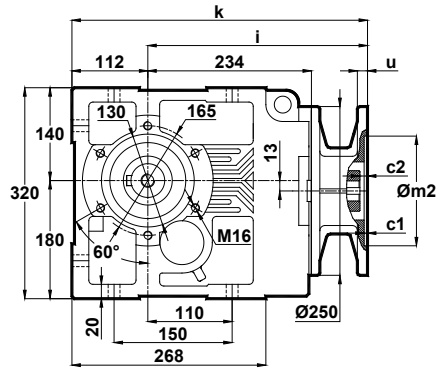

x: Motor Ayak bağlantı yüzeyinin altında ise  
x: If Motor is lower then foot mounting plane  
x: Wenn motor ist niedriger den die Anschlußplatte

	c1	c2	s1	m	m1	m2	i	u	k	d1	t1	e1	x
80/B5	4	5	12	162	200	130	291	12	403	19	6	21.8	-
90/B5	4	5	13	165	200	130	291	12	403	24	8	27.3	-
100/B5	4.5	9	15	215	250	180	309	15	421	28	8	31.3	-
112/B5	4.5	9	15	215	250	180	309	15	421	28	8	31.3	-
132/B5	4.5	6	15	265	300	230	328	15	440	38	10	41.3	-
160/B5	5.5	10	19	300	350	250	407	20	519	42	12	45.3	8
180/B5	5.5	10	19	300	350	250	407	20	519	48	14	51.8	8

## KN473.05

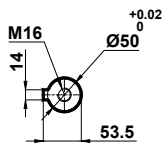
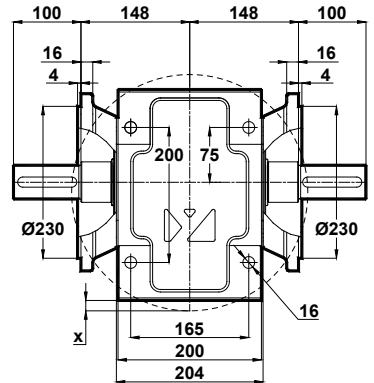
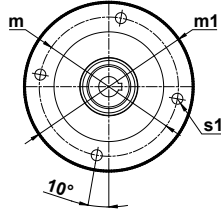
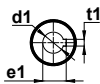
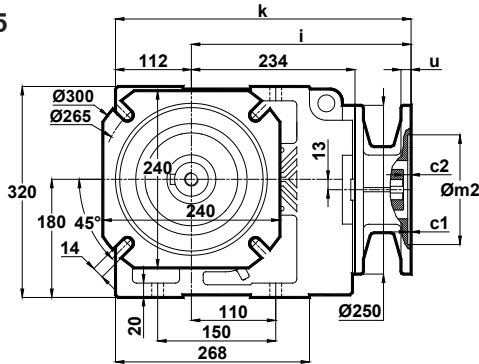

x: Motor Ayak bağlantı yüzeyinin altında ise  
x: If Motor is lower then foot mounting plane  
x: Wenn motor ist niedriger den die Anschlußplatte

	c1	c2	s1	m	m1	m2	i	u	k	d1	t1	e1	x
80/B5	4	5	12	162	200	130	291	12	403	19	6	21.8	-
90/B5	4	5	13	165	200	130	291	12	403	24	8	27.3	-
100/B5	4.5	9	15	215	250	180	309	15	421	28	8	31.3	-
112/B5	4.5	9	15	215	250	180	309	15	421	28	8	31.3	-
132/B5	4.5	6	15	265	300	230	328	15	440	38	10	41.3	-
160/B5	5.5	10	19	300	350	250	407	20	519	42	12	45.3	8
180/B5	5.5	10	19	300	350	250	407	20	519	48	14	51.8	8

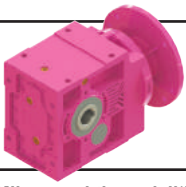

# Ölçü Sayfaları Dimension Pages Abmessungenseiten

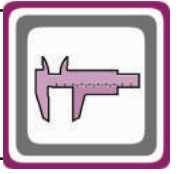

-Mil ucu çektirme deliği DIN 332 sayfa 2 / Tapped center hole to DIN 332, sheet 2 / Zentrierung mit gewinde DIN 332, Blatt 2

KN473.08

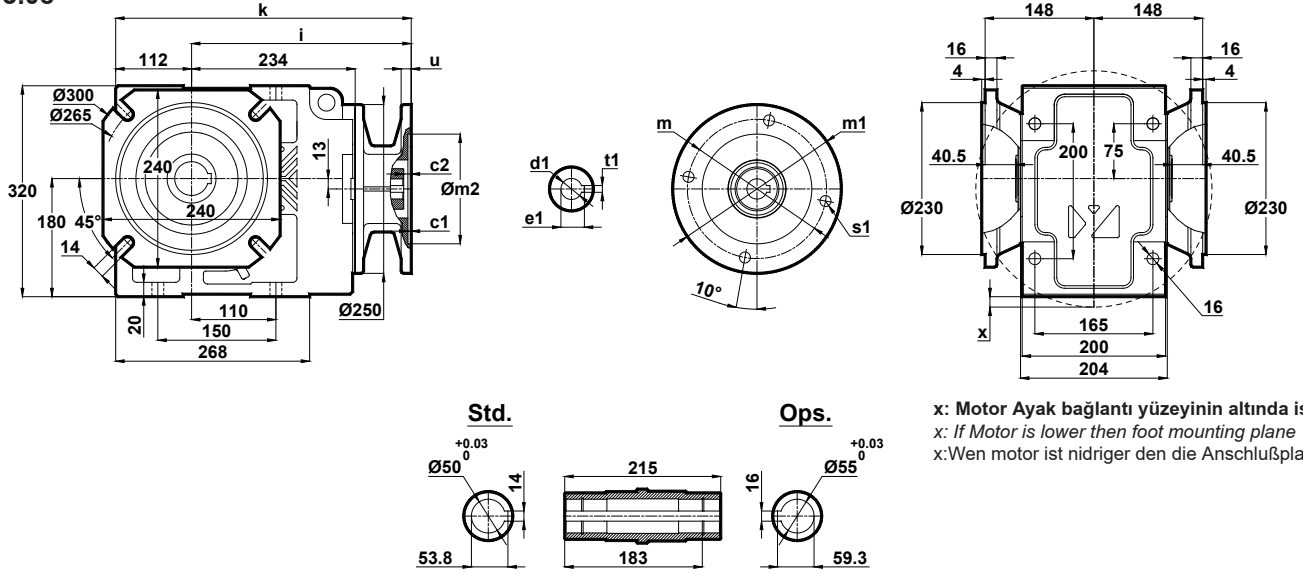

	c1	c2	s1	m	m1	m2	i	u	k	d1	t1	e1	x
80/B5	4	5	12	162	200	130	291	12	403	19	6	21.8	-
90/B5	4	5	13	165	200	130	291	12	403	24	8	27.3	-
100/B5	4.5	9	15	215	250	180	309	15	421	28	8	31.3	-
112/B5	4.5	9	15	215	250	180	309	15	421	28	8	31.3	-
132/B5	4.5	6	15	265	300	230	328	15	440	38	10	41.3	-
160/B5	5.5	10	19	300	350	250	407	20	519	42	12	45.3	8
180/B5	5.5	10	19	300	350	250	407	20	519	48	14	51.8	8

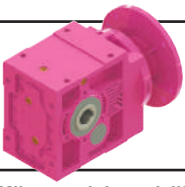

# Ölçü Sayfaları Dimension Pages Abmessungsseiten

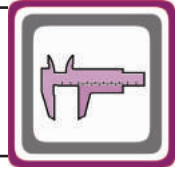

-Mil ucu çekirme deliği DIN 332 sayfa 2 / Tapped center hole to DIN 332, sheet 2 / Zentrierung mit gewinde DIN 332, Blatt 2

## KN474.00

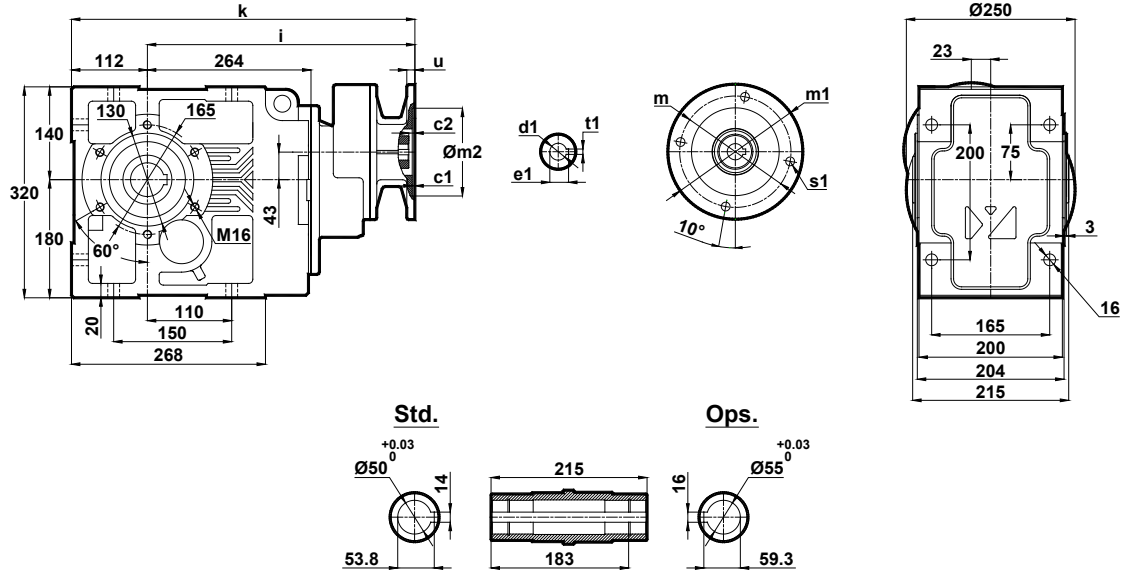

	c1	c2	s1	m	m1	m2	i	u	k	d1	t1	e1
71/B5	4	9	11	130	160	110	389	12	501	14	5	16.3
80/B5	4	9	13	165	200	130	389	12	501	19	6	21.8

## KN474.01

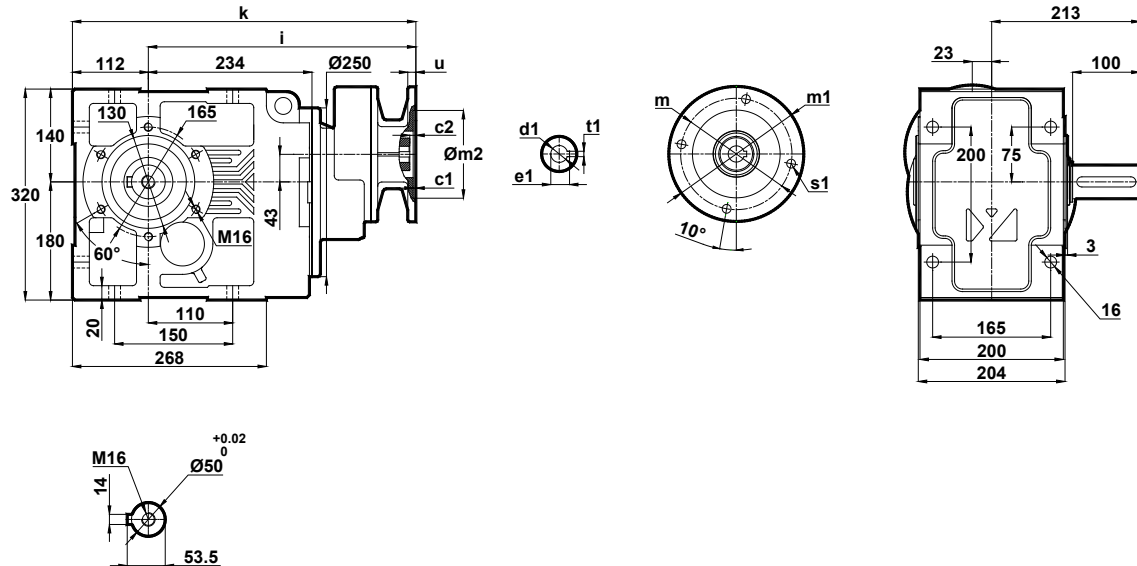

	c1	c2	s1	m	m1	m2	i	u	k	d1	t1	e1
71/B5	4	9	11	130	160	110	389	12	501	14	5	16.3
80/B5	4	9	13	165	200	130	389	12	501	19	6	21.8

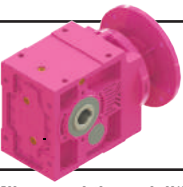

# Ölçü Sayfaları Dimension Pages Abmessungsseiten

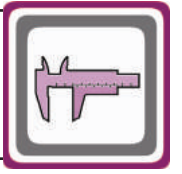

-Mil ucu çekirme deliği DIN 332 sayfa 2 / Tapped center hole to DIN 332, sheet 2 / Zentrierung mit gewinde DIN 332, Blatt 2

## KN474.02

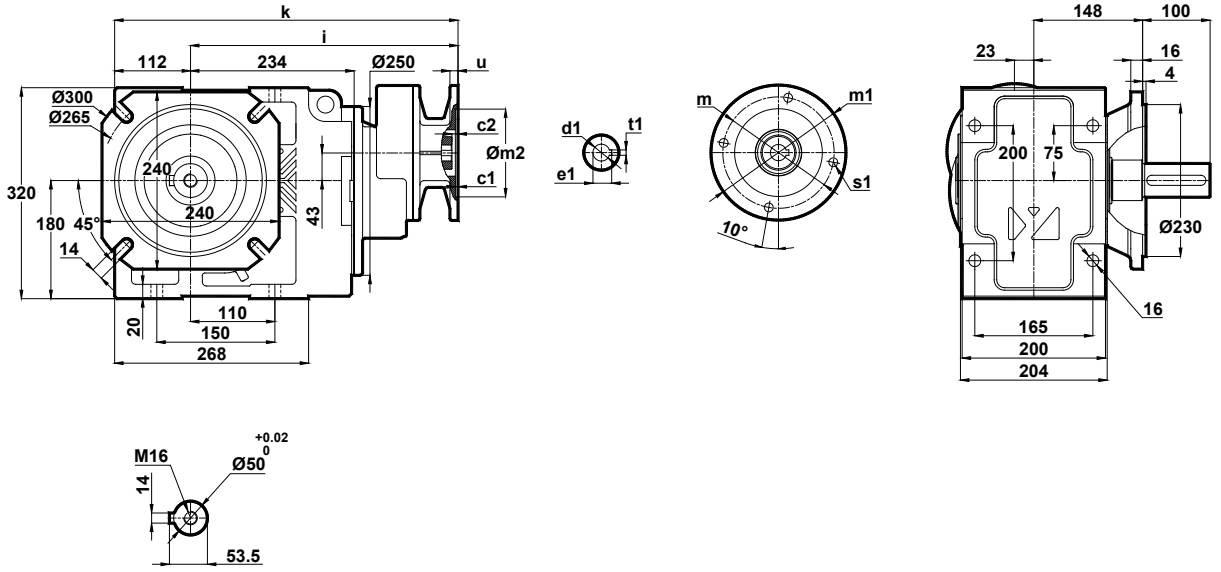

	c1	c2	s1	m	m1	m2	i	u	k	d1	t1	e1
71/B5	4	9	11	130	160	110	389	12	501	14	5	16.3
80/B5	4	9	13	165	200	130	389	12	501	19	6	21.8

## KN474.03

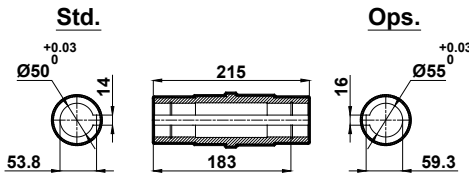
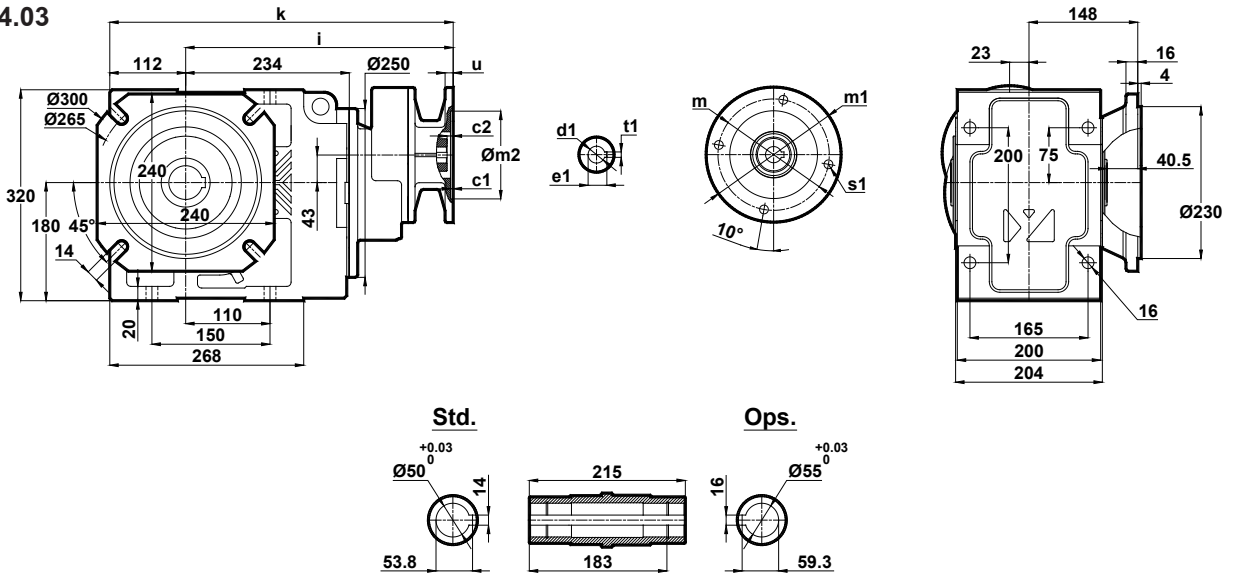

	c1	c2	s1	m	m1	m2	i	u	k	d1	t1	e1
71/B5	4	9	11	130	160	110	389	12	501	14	5	16.3
80/B5	4	9	13	165	200	130	389	12	501	19	6	21.8

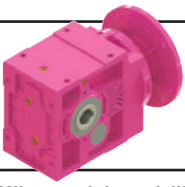

# Ölçü Sayfaları

## Dimension Pages

### Abmessungsseiten

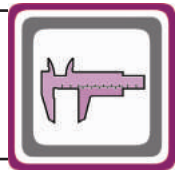

-Mil ucu çekirme deliği DIN 332 sayfa 2 / Tapped center hole to DIN 332, sheet 2 / Zentrierung mit gewinde DIN 332, Blatt 2

#### KN474.04

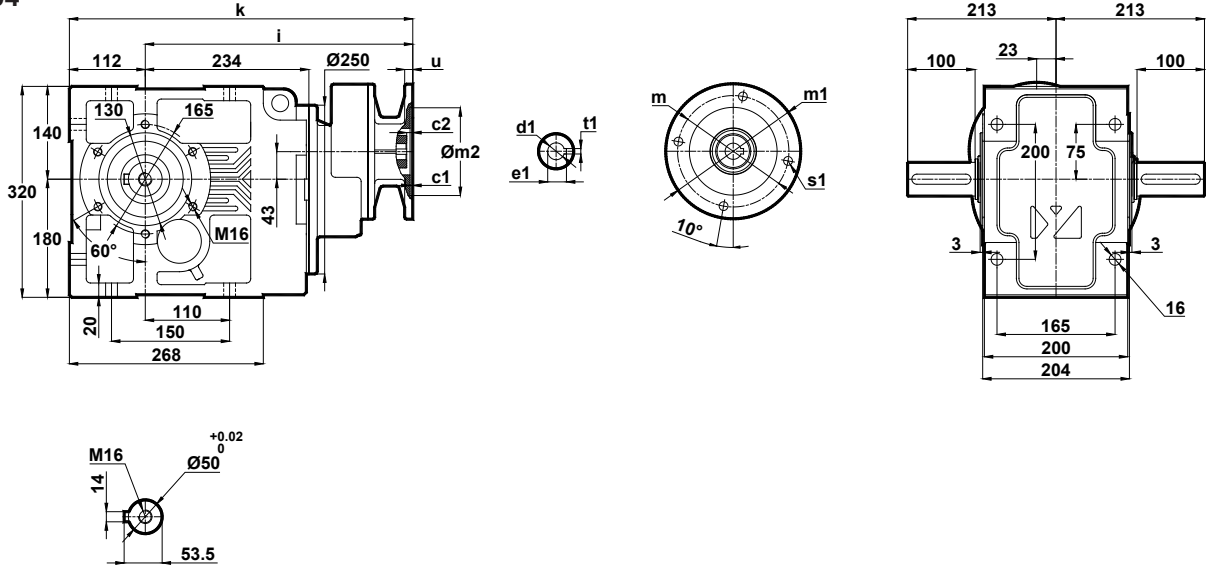

	c1	c2	s1	m	m1	m2	i	u	k	d1	t1	e1
71/B5	4	9	11	130	160	110	389	12	501	14	5	16.3
80/B5	4	9	13	165	200	130	389	12	501	19	6	21.8

#### KN474.05

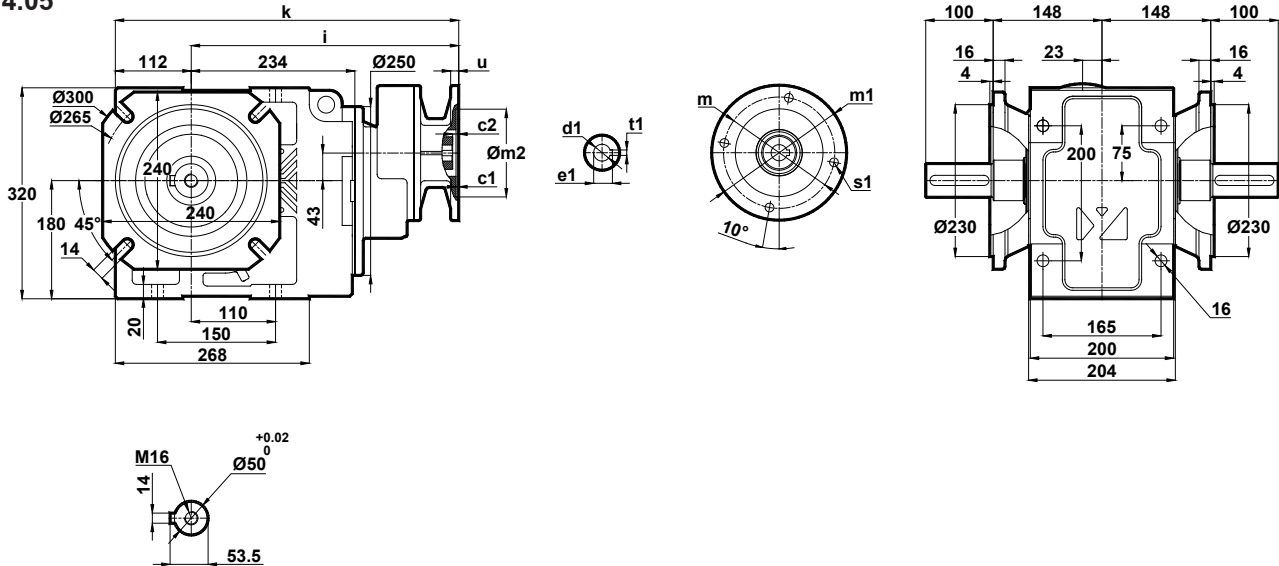

	c1	c2	s1	m	m1	m2	i	u	k	d1	t1	e1
71/B5	4	9	11	130	160	110	389	12	501	14	5	16.3
80/B5	4	9	13	165	200	130	389	12	501	19	6	21.8

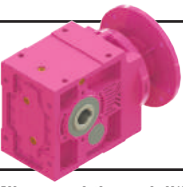

# Ölçü Sayfaları Dimension Pages Abmessungsseiten

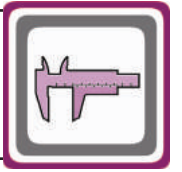

-Mil ucu çekirme deliği DIN 332 sayfa 2 / Tapped center hole to DIN 332, sheet 2 / Zentrierung mit gewinde DIN 332, Blatt 2

KN474.08

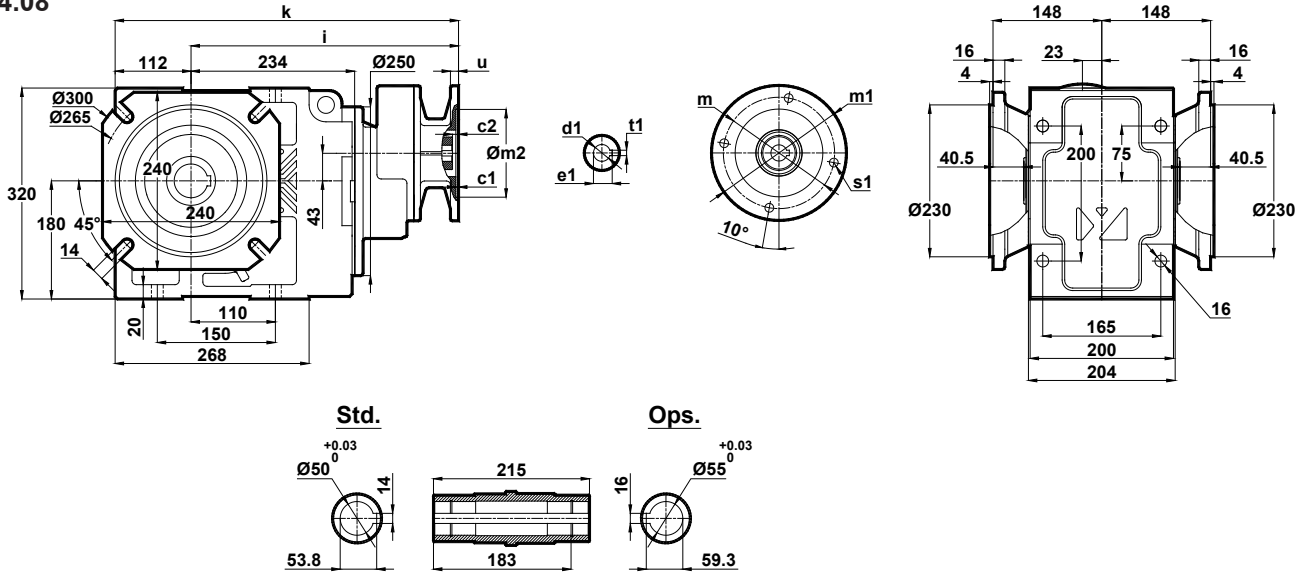

	c1	c2	s1	m	m1	m2	i	u	k	d1	t1	e1
71/B5	4	9	11	130	160	110	389	12	501	14	5	16.3
80/B5	4	9	13	165	200	130	389	12	501	19	6	21.8

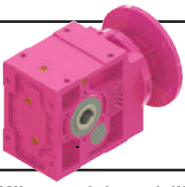

# Ölçü Sayfaları Dimension Pages Abmessungsseiten

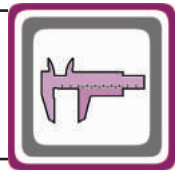

-Mil ucu çekirme deliği DIN 332 sayfa 2 / Tapped center hole to DIN 332, sheet 2 / Zentrierung mit gewinde DIN 332, Blatt 2

KN475.00  
KN476.00

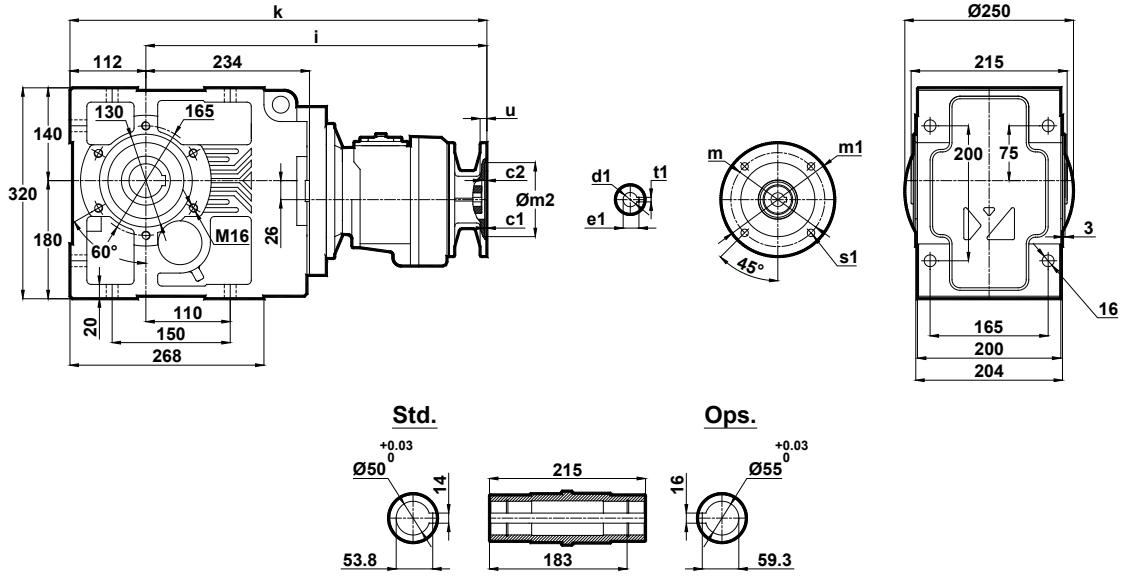

	c1	c2	s1	m	m1	m2	i	u	k	d1	t1	e1
63/B5	4	8	9	115	140	95	517	12	629	11	4	12.8
71/B5	4	8.5	11	130	160	110	488	12	600	14	5	16.3

KN475.01  
KN476.01

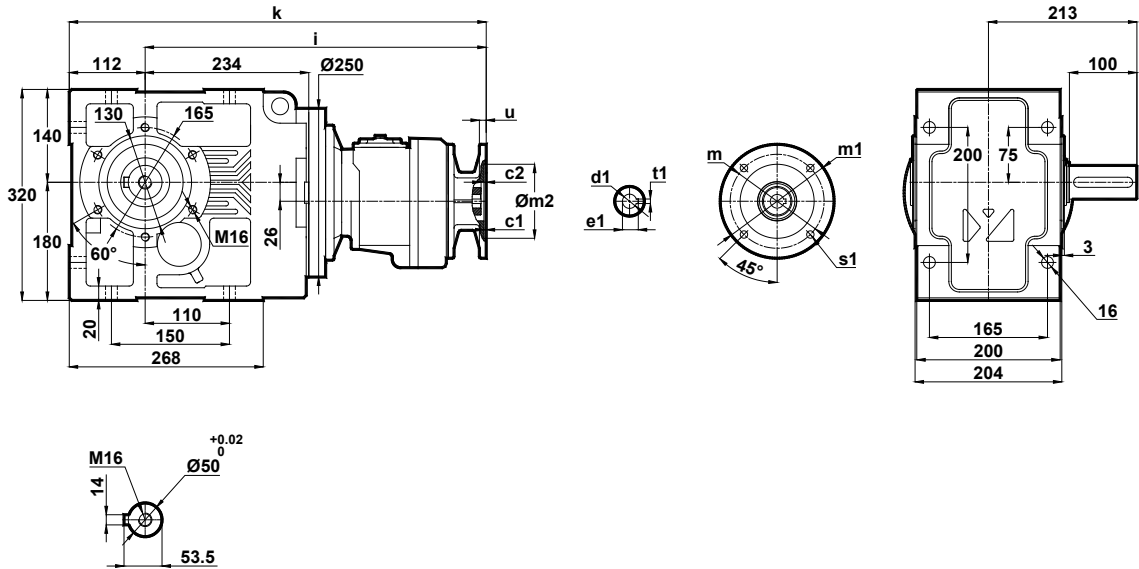

	c1	c2	s1	m	m1	m2	i	u	k	d1	t1	e1
63/B5	4	8	9	115	140	95	517	12	629	11	4	12.8
71/B5	4	8.5	11	130	160	110	488	12	600	14	5	16.3

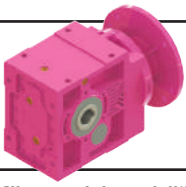

# Ölçü Sayfaları Dimension Pages Abmessungenseiten

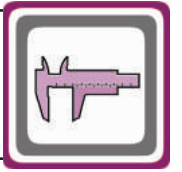

-Mil ucu çekirme deliği DIN 332 sayfa 2 / Tapped center hole to DIN 332, sheet 2 / Zentrierung mit gewinde DIN 332, Blatt 2

KN475.02  
KN476.02

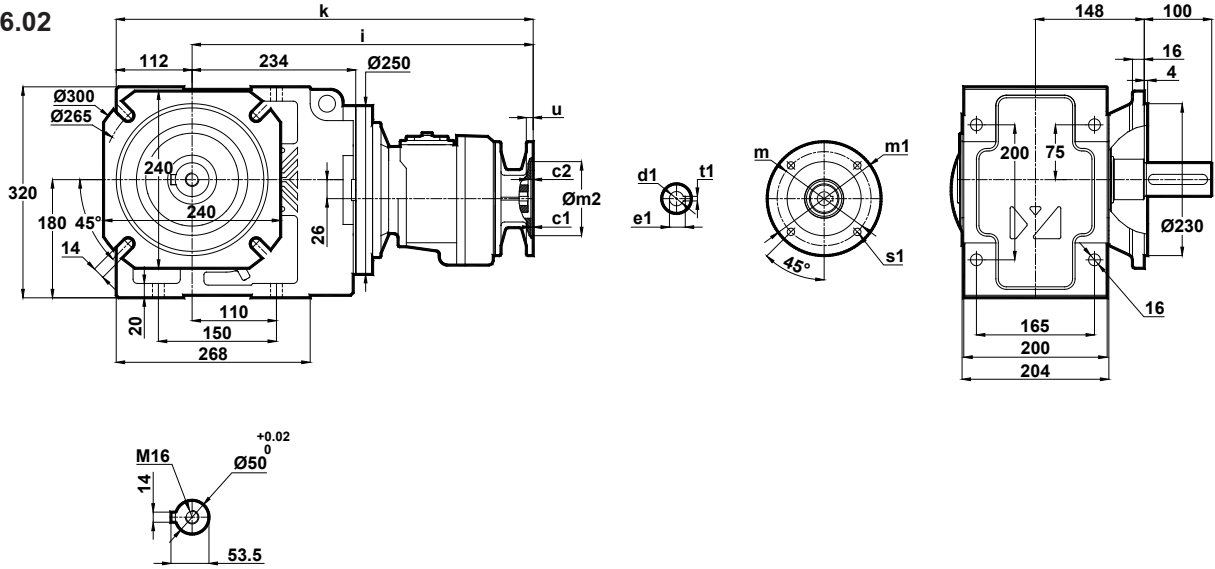

	c1	c2	s1	m	m1	m2	i	u	k	d1	t1	e1
63/B5	4	8	9	115	140	95	517	12	629	11	4	12.8
71/B5	4	8.5	11	130	160	110	488	12	600	14	5	16.3

KN475.03  
KN476.03

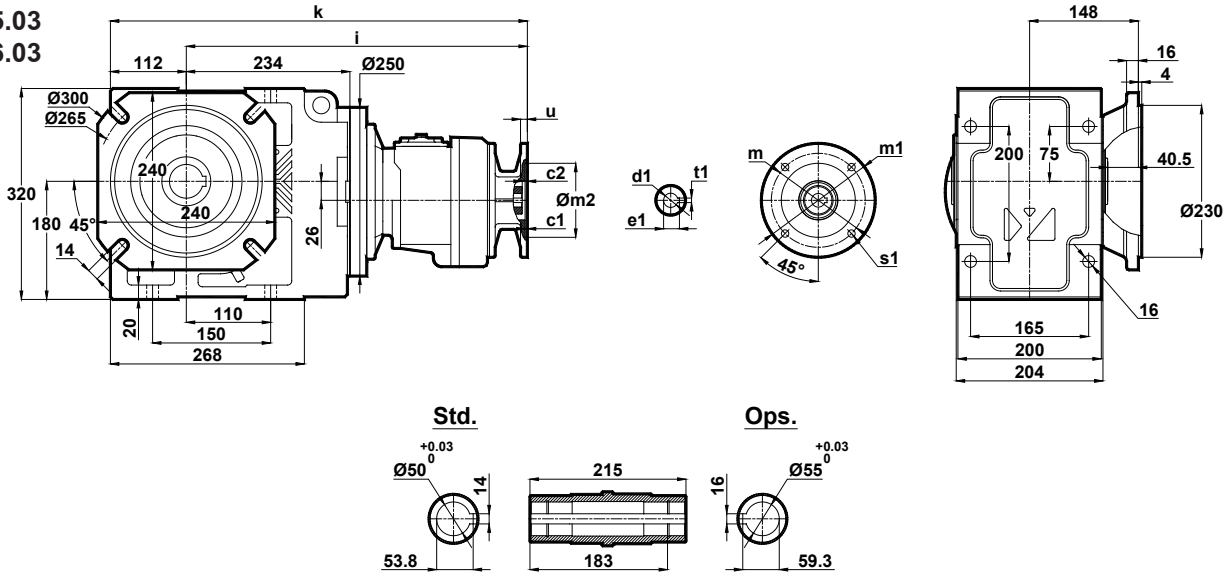

	c1	c2	s1	m	m1	m2	i	u	k	d1	t1	e1
63/B5	4	8	9	115	140	95	517	12	629	11	4	12.8
71/B5	4	8.5	11	130	160	110	488	12	600	14	5	16.3

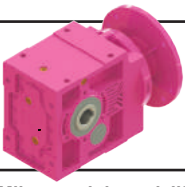

# Ölçü Sayfaları

## Dimension Pages

### Abmessungsseiten

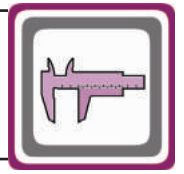

-Mil ucu çektirme deliği DIN 332 sayfa 2 / Tapped center hole to DIN 332, sheet 2 / Zentrierung mit gewinde DIN 332, Blatt 2

KN475.04  
KN476.04

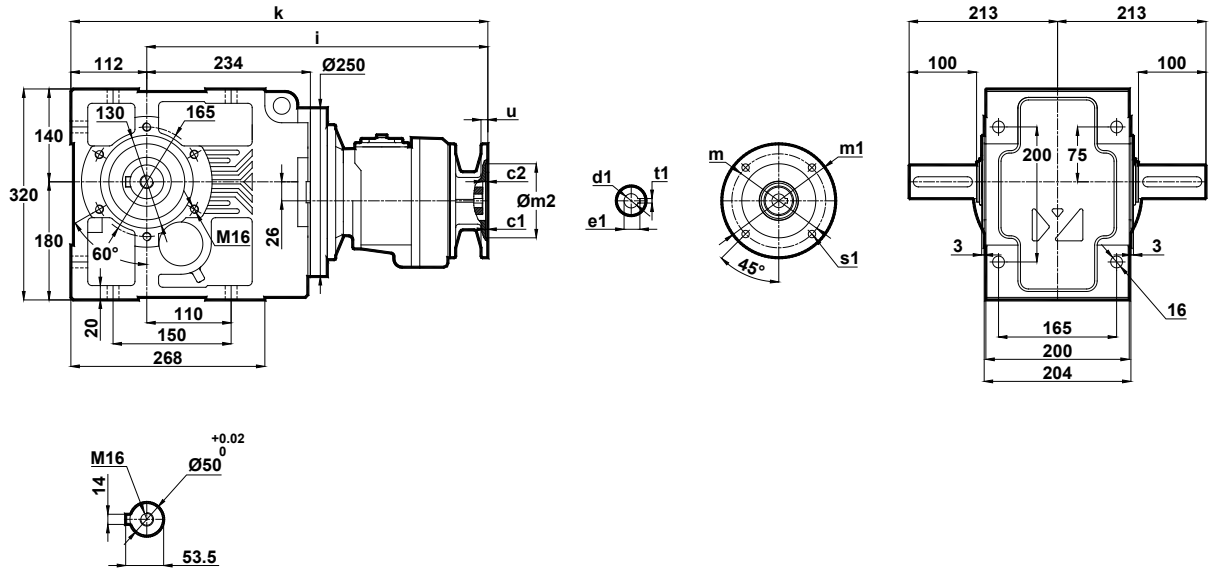

	c1	c2	s1	m	m1	m2	i	u	k	d1	t1	e1
63/B5	4	8	9	115	140	95	517	12	629	11	4	12.8
71/B5	4	8.5	11	130	160	110	488	12	600	14	5	16.3

KN475.05  
KN476.05

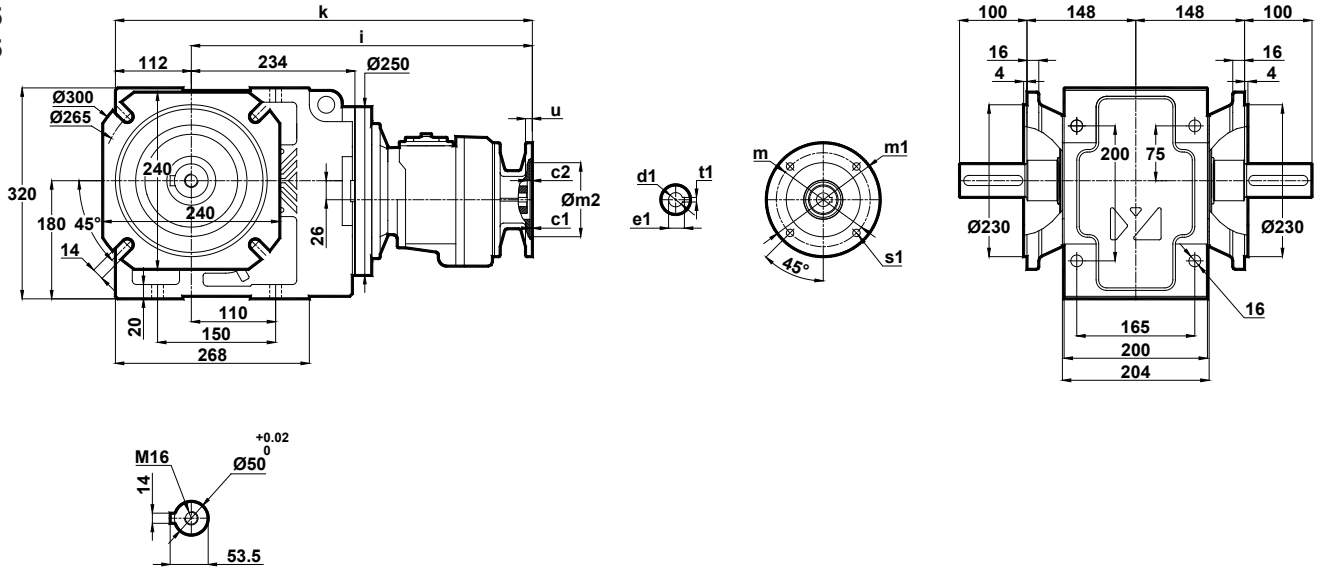

	c1	c2	s1	m	m1	m2	i	u	k	d1	t1	e1
63/B5	4	8	9	115	140	95	517	12	629	11	4	12.8
71/B5	4	8.5	11	130	160	110	488	12	600	14	5	16.3

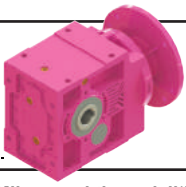

# Ölçü Sayfaları Dimension Pages Abmessungenseiten

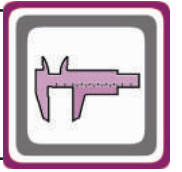

-Mil ucu çekirme deliği DIN 332 sayfa 2 / Tapped center hole to DIN 332, sheet 2 / Zentrierung mit gewinde DIN 332, Blatt 2

KN475.08  
KN476.08

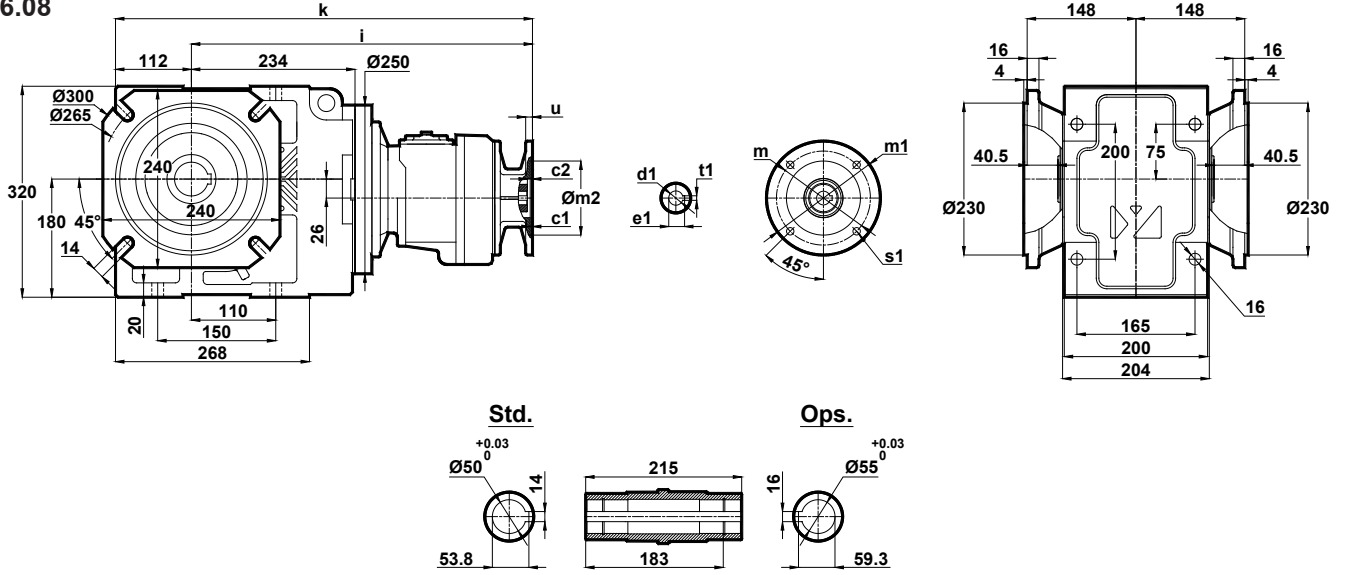

	c1	c2	s1	m	m1	m2	i	u	k	d1	t1	e1
63/B5	4	8	9	115	140	95	517	12	629	11	4	12.8
71/B5	4	8.5	11	130	160	110	488	12	600	14	5	16.3

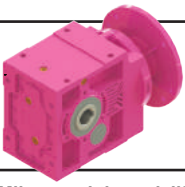

# Ölçü Sayfaları Dimension Pages Abmessungsseiten

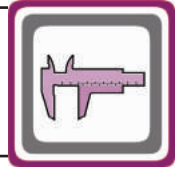

-Mil ucu çekirme deliği DIN 332 sayfa 2 / Tapped center hole to DIN 332, sheet 2 / Zentrierung mit gewinde DIN 332, Blatt 2

## KN573.00

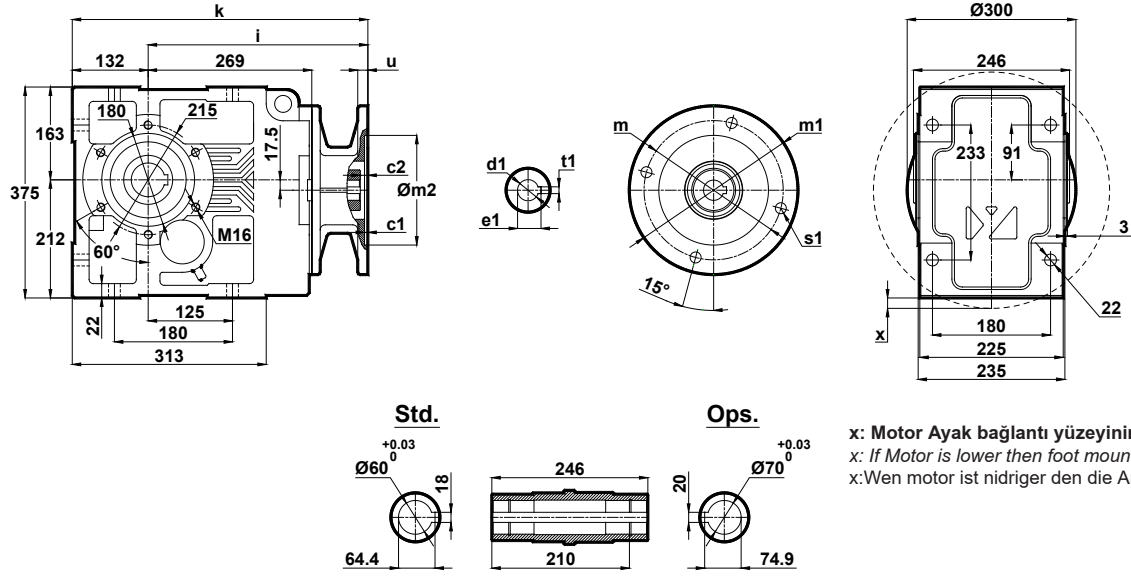

x: Motor Ayak bağlantı yüzeyinin altında ise  
x: If Motor is lower then foot mounting plane  
x: Wenn motor ist niedriger den die Anschlußplatte

	c1	c2	s1	m	m1	m2	i	u	k	d1	t1	e1	x
100/B5	4.5	20	15	215	250	180	342	15	474	28	8	31.3	-
112/B5	4.5	20	15	215	250	180	342	15	474	28	8	31.3	-
132/B5	4.5	9	15	265	300	230	363	15	495	38	10	41.3	-
160/B5	5.5	10	19	300	350	250	438	18	570	42	12	45.3	-
180/B5	5.5	10	19	300	350	250	438	18	570	48	14	51.8	-

## KN573.01

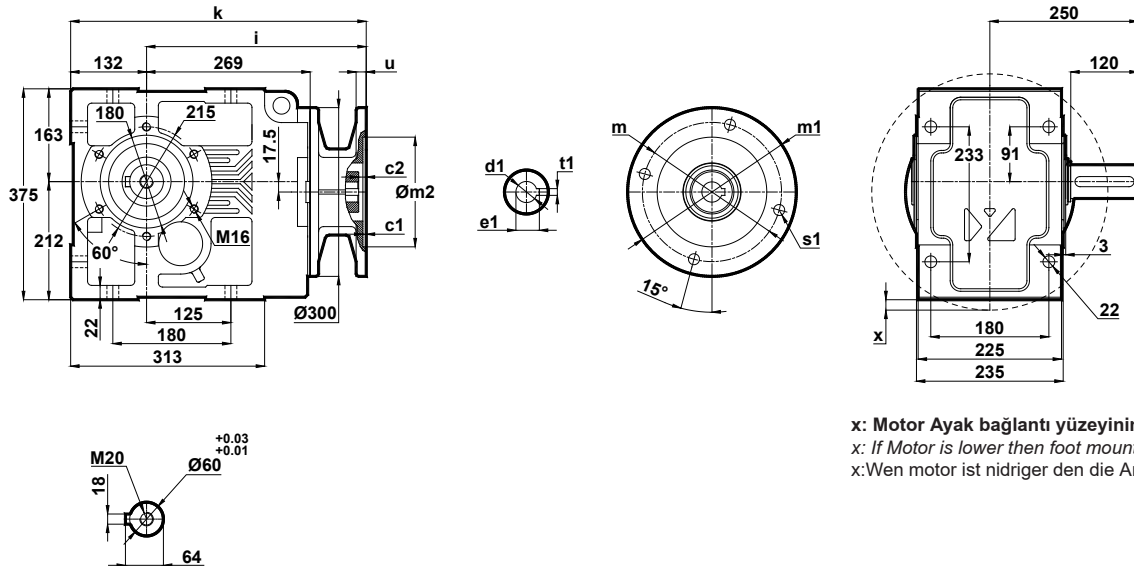

x: Motor Ayak bağlantı yüzeyinin altında ise  
x: If Motor is lower then foot mounting plane  
x: Wenn motor ist niedriger den die Anschlußplatte

	c1	c2	s1	m	m1	m2	i	u	k	d1	t1	e1	x
100/B5	4.5	20	15	215	250	180	342	15	474	28	8	31.3	-
112/B5	4.5	20	15	215	250	180	342	15	474	28	8	31.3	-
132/B5	4.5	9	15	265	300	230	363	15	495	38	10	41.3	-
160/B5	5.5	10	19	300	350	250	438	18	570	42	12	45.3	-
180/B5	5.5	10	19	300	350	250	438	18	570	48	14	51.8	-

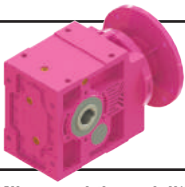

# Ölçü Sayfaları

## Dimension Pages

### Abmessungsseiten

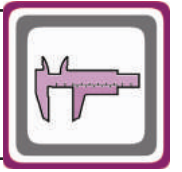

-Mil ucu çekirme deliği DIN 332 sayfa 2 / Tapped center hole to DIN 332, sheet 2 / Zentrierung mit gewinde DIN 332, Blatt 2

#### KN573.02

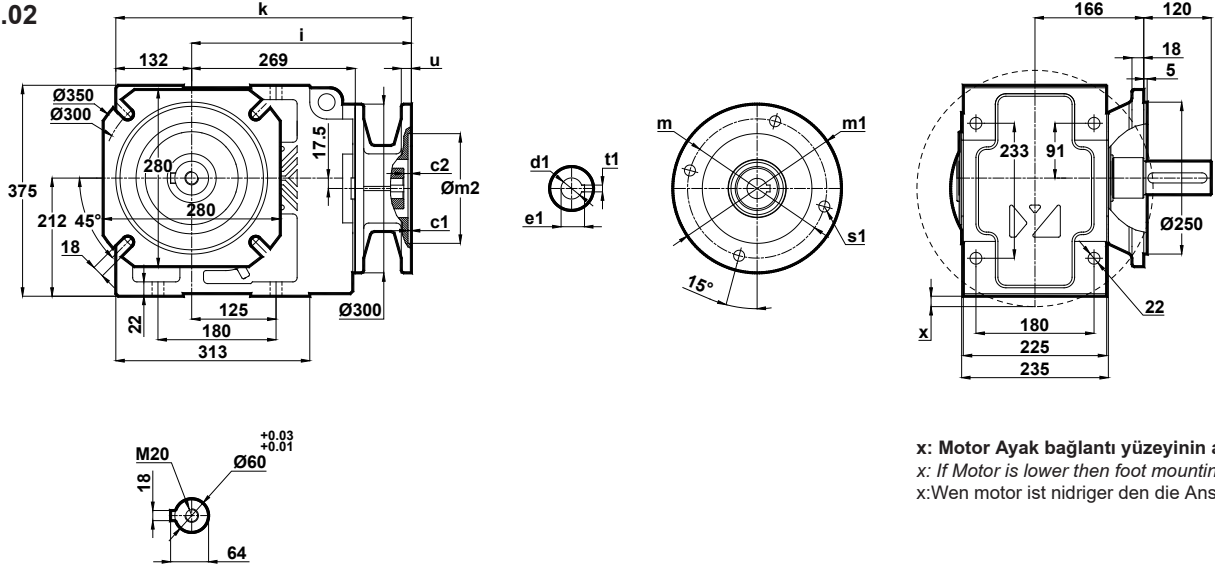

x: Motor Ayak bağlantı yüzeyinin altında ise  
x: If Motor is lower then foot mounting plane  
x: Wenn motor ist niedriger den die Anschlußplatte

	c1	c2	s1	m	m1	m2	i	u	k	d1	t1	e1	x
100/B5	4.5	20	15	215	250	180	342	15	474	28	8	31.3	-
112/B5	4.5	20	15	215	250	180	342	15	474	28	8	31.3	-
132/B5	4.5	9	15	265	300	230	363	15	495	38	10	41.3	-
160/B5	5.5	10	19	300	350	250	438	18	570	42	12	45.3	-
180/B5	5.5	10	19	300	350	250	438	18	570	48	14	51.8	-

#### KN573.03

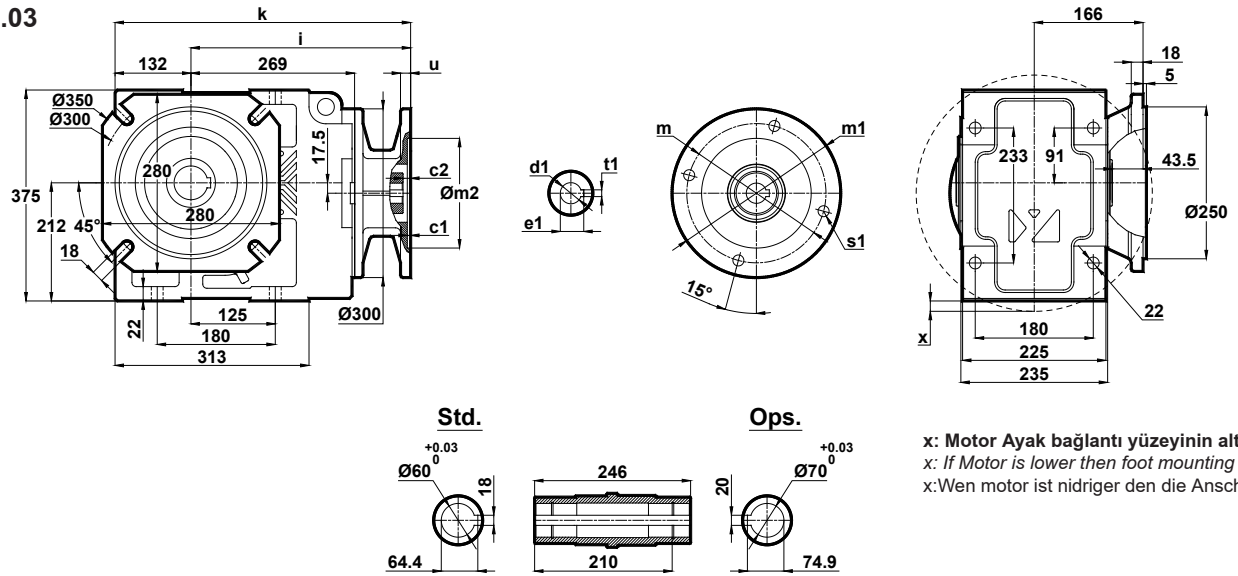

x: Motor Ayak bağlantı yüzeyinin altında ise  
x: If Motor is lower then foot mounting plane  
x: Wenn motor ist niedriger den die Anschlußplatte

	c1	c2	s1	m	m1	m2	i	u	k	d1	t1	e1	x
100/B5	4.5	20	15	215	250	180	342	15	474	28	8	31.3	-
112/B5	4.5	20	15	215	250	180	342	15	474	28	8	31.3	-
132/B5	4.5	9	15	265	300	230	363	15	495	38	10	41.3	-
160/B5	5.5	10	19	300	350	250	438	18	570	42	12	45.3	-
180/B5	5.5	10	19	300	350	250	438	18	570	48	14	51.8	-

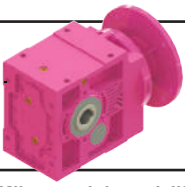

# Ölçü Sayfaları Dimension Pages Abmessungsseiten

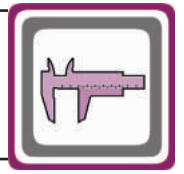

-Mil ucu çekirme deliği DIN 332 sayfa 2 / Tapped center hole to DIN 332, sheet 2 / Zentrierung mit gewinde DIN 332, Blatt 2

## KN573.04

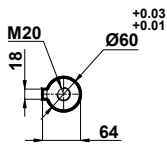
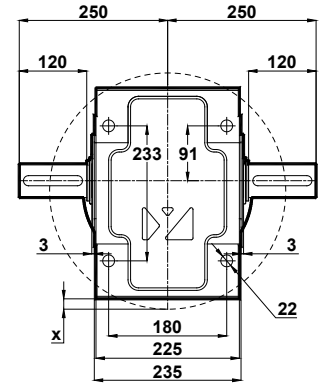
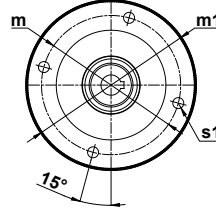
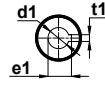
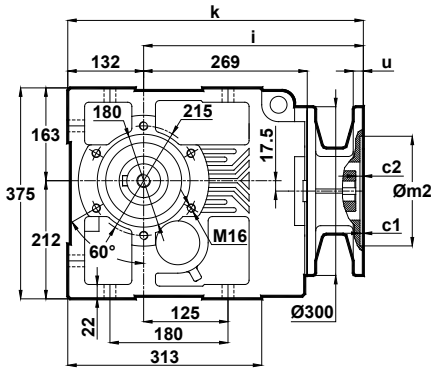

x: Motor Ayak bağlantı yüzeyinin altında ise  
x: If Motor is lower then foot mounting plane  
x: Wenn motor ist niedriger den die Anschlußplatte

	c1	c2	s1	m	m1	m2	i	u	k	d1	t1	e1	x
100/B5	4.5	20	15	215	250	180	342	15	474	28	8	31.3	-
112/B5	4.5	20	15	215	250	180	342	15	474	28	8	31.3	-
132/B5	4.5	9	15	265	300	230	363	15	495	38	10	41.3	-
160/B5	5.5	10	19	300	350	250	438	18	570	42	12	45.3	-
180/B5	5.5	10	19	300	350	250	438	18	570	48	14	51.8	-

## KN573.05

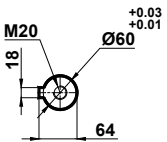
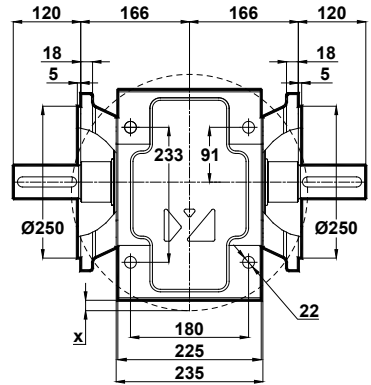
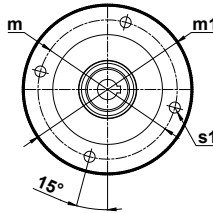
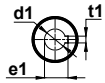
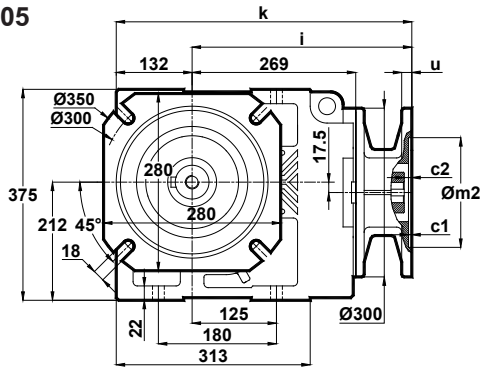

x: Motor Ayak bağlantı yüzeyinin altında ise  
x: If Motor is lower then foot mounting plane  
x: Wenn motor ist niedriger den die Anschlußplatte

	c1	c2	s1	m	m1	m2	i	u	k	d1	t1	e1	x
100/B5	4.5	20	15	215	250	180	342	15	474	28	8	31.3	-
112/B5	4.5	20	15	215	250	180	342	15	474	28	8	31.3	-
132/B5	4.5	9	15	265	300	230	363	15	495	38	10	41.3	-
160/B5	5.5	10	19	300	350	250	438	18	570	42	12	45.3	-
180/B5	5.5	10	19	300	350	250	438	18	570	48	14	51.8	-

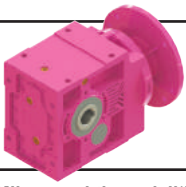

# Ölçü Sayfaları Dimension Pages Abmessungenseiten

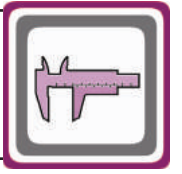

-Mil ucu çekirme deliği DIN 332 sayfa 2 / Tapped center hole to DIN 332, sheet 2 / Zentrierung mit gewinde DIN 332, Blatt 2

KN573.08

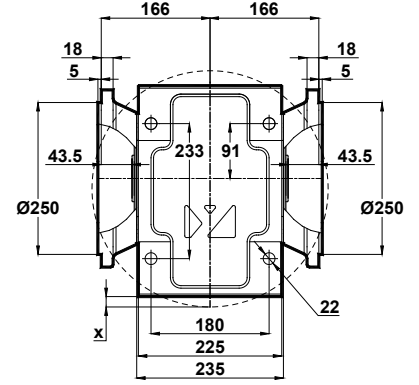
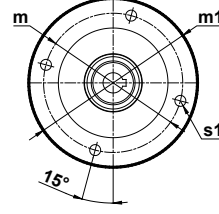
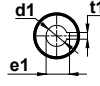
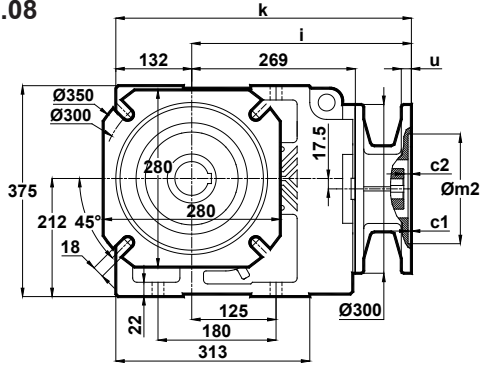

Std.

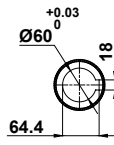

Ops.

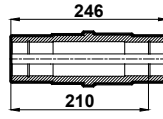
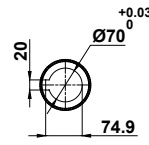

x: Motor Ayak bağlantı yüzeyinin altında ise  
x: If Motor is lower then foot mounting plane  
x: Wenn motor ist niedriger den die Anschlußplatte

	c1	c2	s1	m	m1	m2	i	u	k	d1	t1	e1	x
100/B5	4.5	20	15	215	250	180	342	15	474	28	8	31.3	-
112/B5	4.5	20	15	215	250	180	342	15	474	28	8	31.3	-
132/B5	4.5	9	15	265	300	230	363	15	495	38	10	41.3	-
160/B5	5.5	10	19	300	350	250	438	18	570	42	12	45.3	-
180/B5	5.5	10	19	300	350	250	438	18	570	48	14	51.8	-

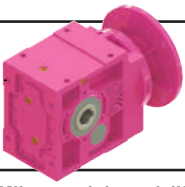

# Ölçü Sayfaları Dimension Pages Abmessungenseiten

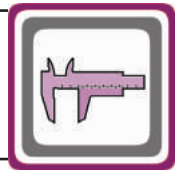

-Mil ucu çekirme deliği DIN 332 sayfa 2 / Tapped center hole to DIN 332, sheet 2 / Zentrierung mit gewinde DIN 332, Blatt 2

## KN574.00

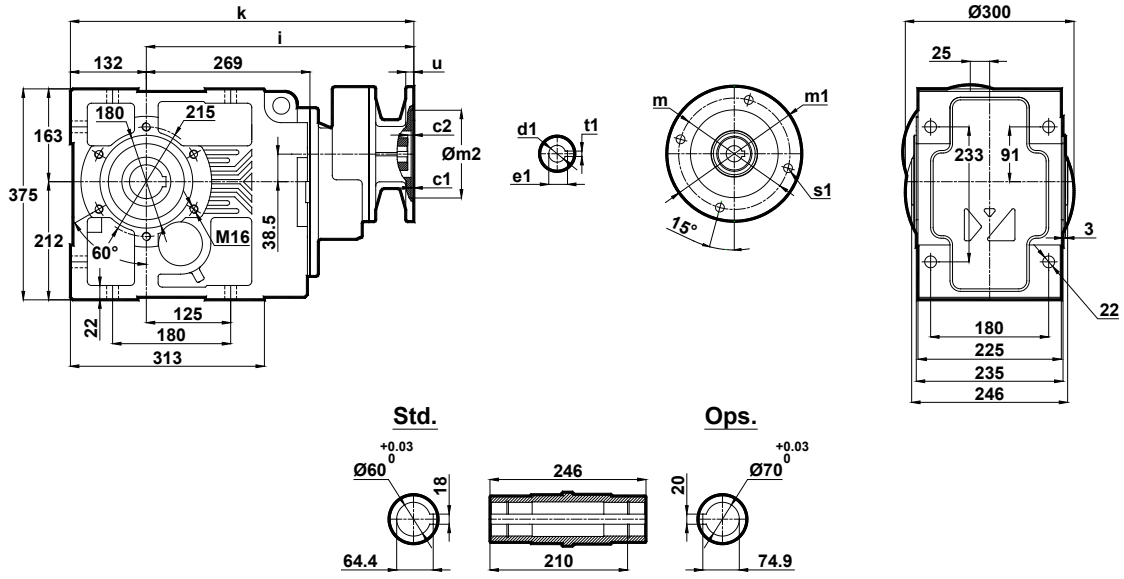

	c1	c2	s1	m	m1	m2	i	u	k	d1	t1	e1
71/B5	4	9	11	130	160	110	422	12	554	14	5	16.3
80/B5	4	9	13	165	200	130	422	12	554	19	6	21.8
90/B5	4	9	13	165	200	130	422	12	554	24	8	27.3
100/B5	4.5	9	15	215	250	180	439	15	571	28	8	31.3

## KN574.01

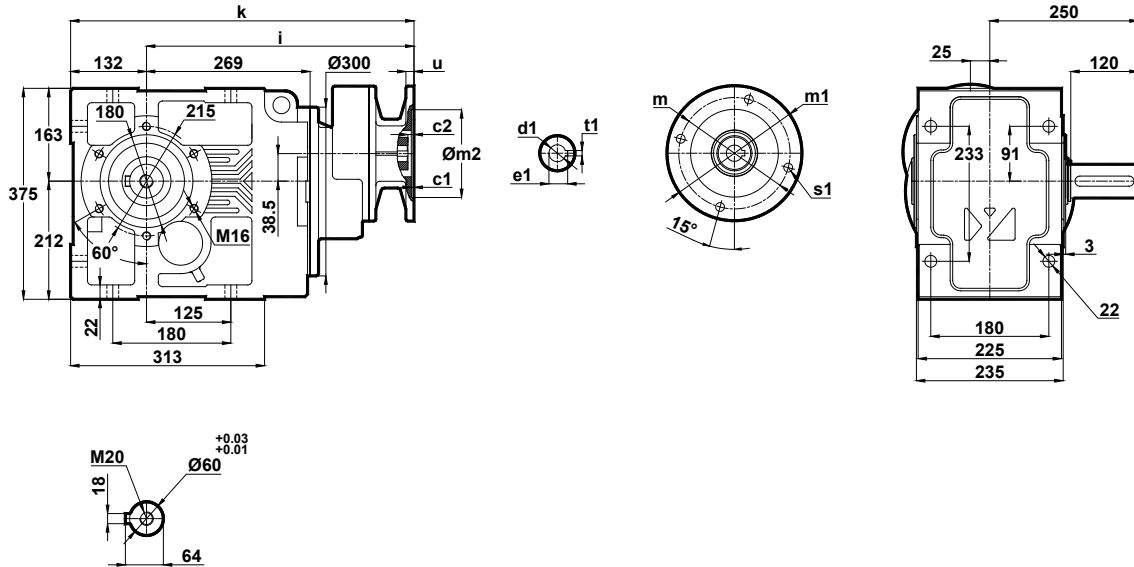

	c1	c2	s1	m	m1	m2	i	u	k	d1	t1	e1
71/B5	4	9	11	130	160	110	422	12	554	14	5	16.3
80/B5	4	9	13	165	200	130	422	12	554	19	6	21.8
90/B5	4	9	13	165	200	130	422	12	554	24	8	27.3
100/B5	4.5	9	15	215	250	180	439	15	571	28	8	31.3

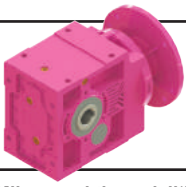

# Ölçü Sayfaları Dimension Pages Abmessungenseiten

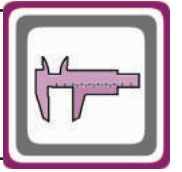

-Mil ucu çektirme deliği DIN 332 sayfa 2 / Tapped center hole to DIN 332, sheet 2 / Zentrierung mit gewinde DIN 332, Blatt 2

## KN574.02

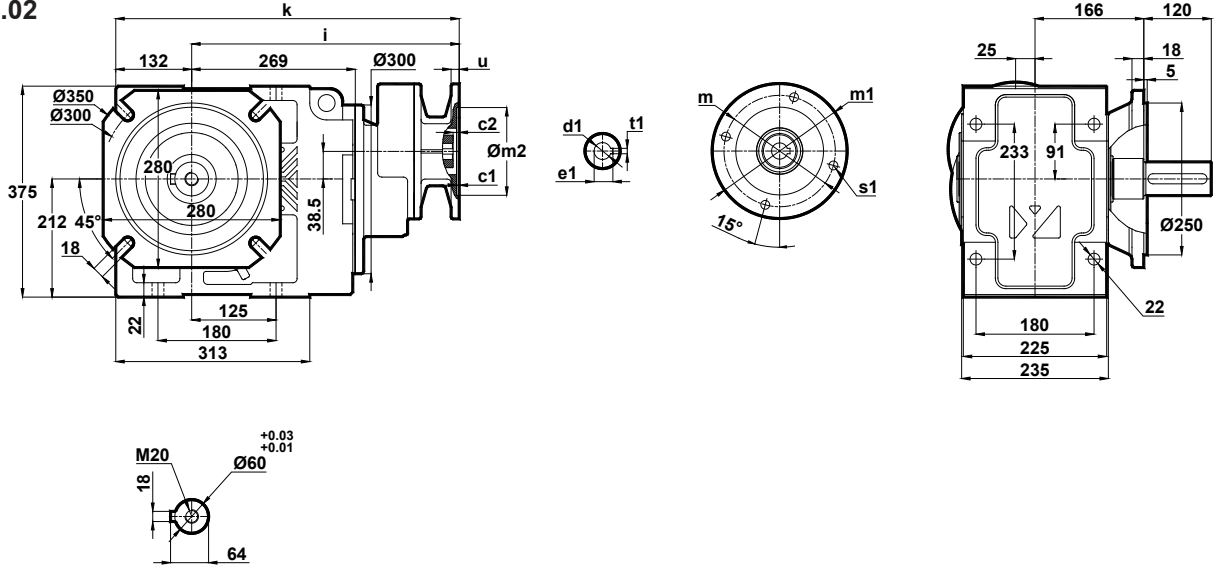

	c1	c2	s1	m	m1	m2	i	u	k	d1	t1	e1
71/B5	4	9	11	130	160	110	422	12	554	14	5	16.3
80/B5	4	9	13	165	200	130	422	12	554	19	6	21.8
90/B5	4	9	13	165	200	130	422	12	554	24	8	27.3
100/B5	4.5	9	15	215	250	180	439	15	571	28	8	31.3

## KN574.03

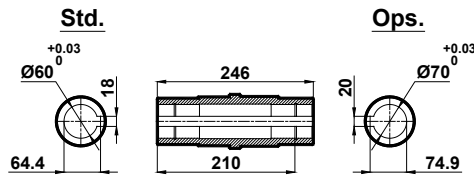
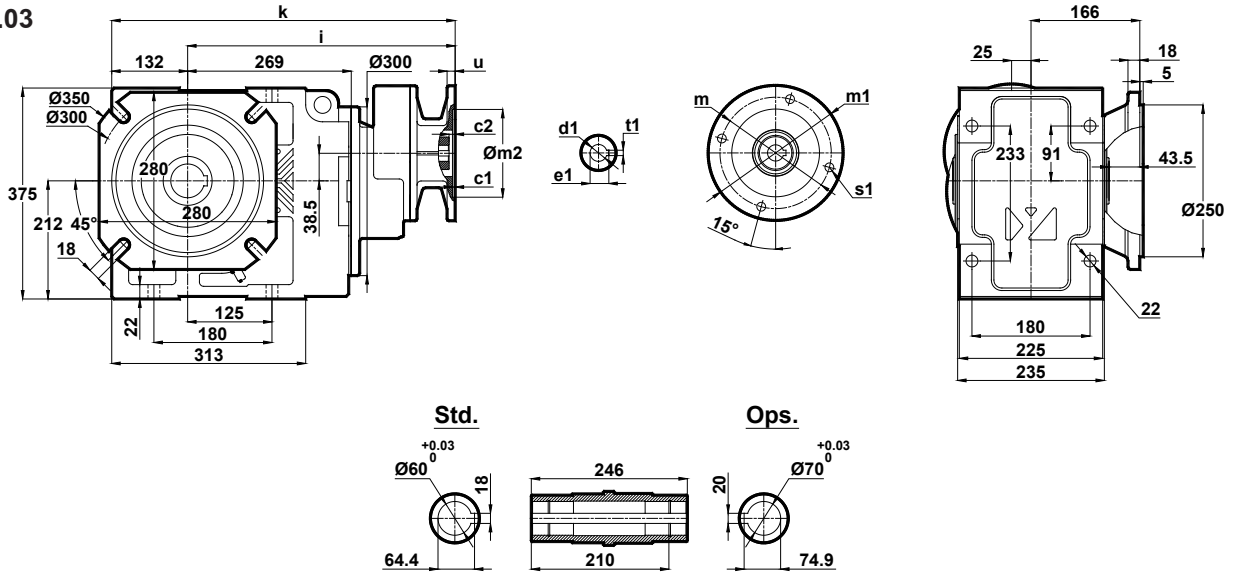

	c1	c2	s1	m	m1	m2	i	u	k	d1	t1	e1
71/B5	4	9	11	130	160	110	422	12	554	14	5	16.3
80/B5	4	9	13	165	200	130	422	12	554	19	6	21.8
90/B5	4	9	13	165	200	130	422	12	554	24	8	27.3
100/B5	4.5	9	15	215	250	180	439	15	571	28	8	31.3

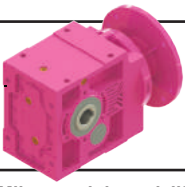

# Ölçü Sayfaları Dimension Pages Abmessungenseiten

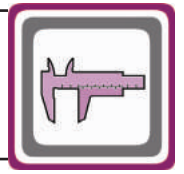

-Mil ucu çektirme deliği DIN 332 sayfa 2 / Tapped center hole to DIN 332, sheet 2 / Zentrierung mit gewinde DIN 332, Blatt 2

## KN574.04

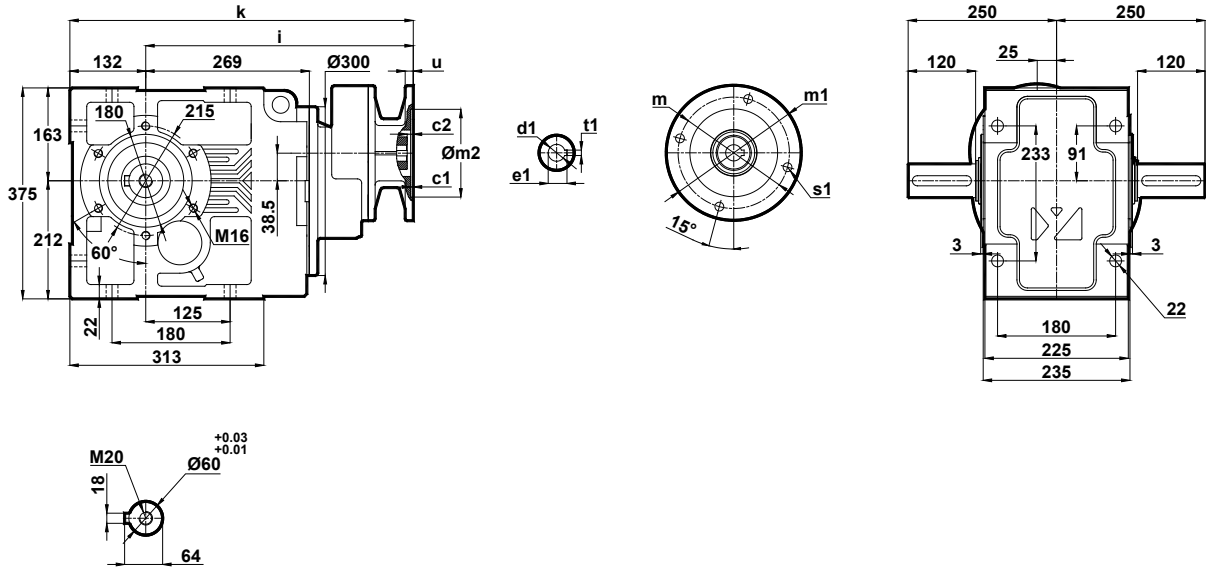

	c1	c2	s1	m	m1	m2	i	u	k	d1	t1	e1
71/B5	4	9	11	130	160	110	422	12	554	14	5	16.3
80/B5	4	9	13	165	200	130	422	12	554	19	6	21.8
90/B5	4	9	13	165	200	130	422	12	554	24	8	27.3
100/B5	4.5	9	15	215	250	180	439	15	571	28	8	31.3

## KN574.05

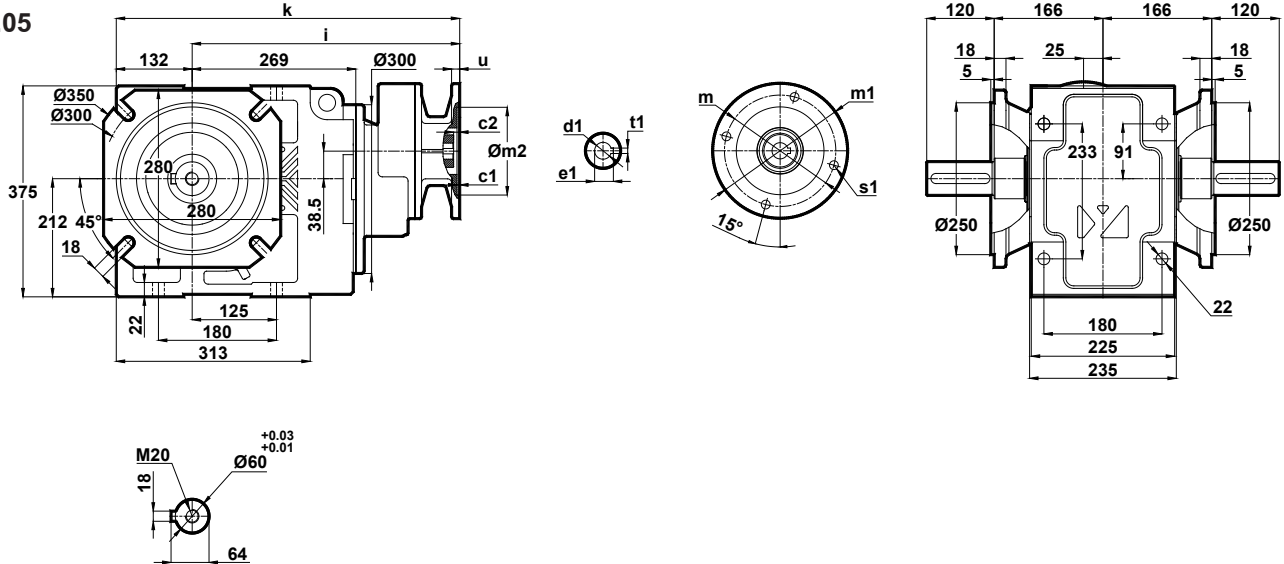

	c1	c2	s1	m	m1	m2	i	u	k	d1	t1	e1
71/B5	4	9	11	130	160	110	422	12	554	14	5	16.3
80/B5	4	9	13	165	200	130	422	12	554	19	6	21.8
90/B5	4	9	13	165	200	130	422	12	554	24	8	27.3
100/B5	4.5	9	15	215	250	180	439	15	571	28	8	31.3

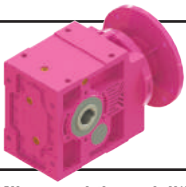

# Ölçü Sayfaları

## Dimension Pages

### Abmessungsseiten

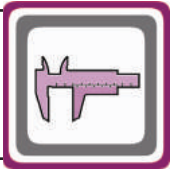

-Mil ucu çekirme deliği DIN 332 sayfa 2 / Tapped center hole to DIN 332, sheet 2 / Zentrierung mit gewinde DIN 332, Blatt 2

KN574.08

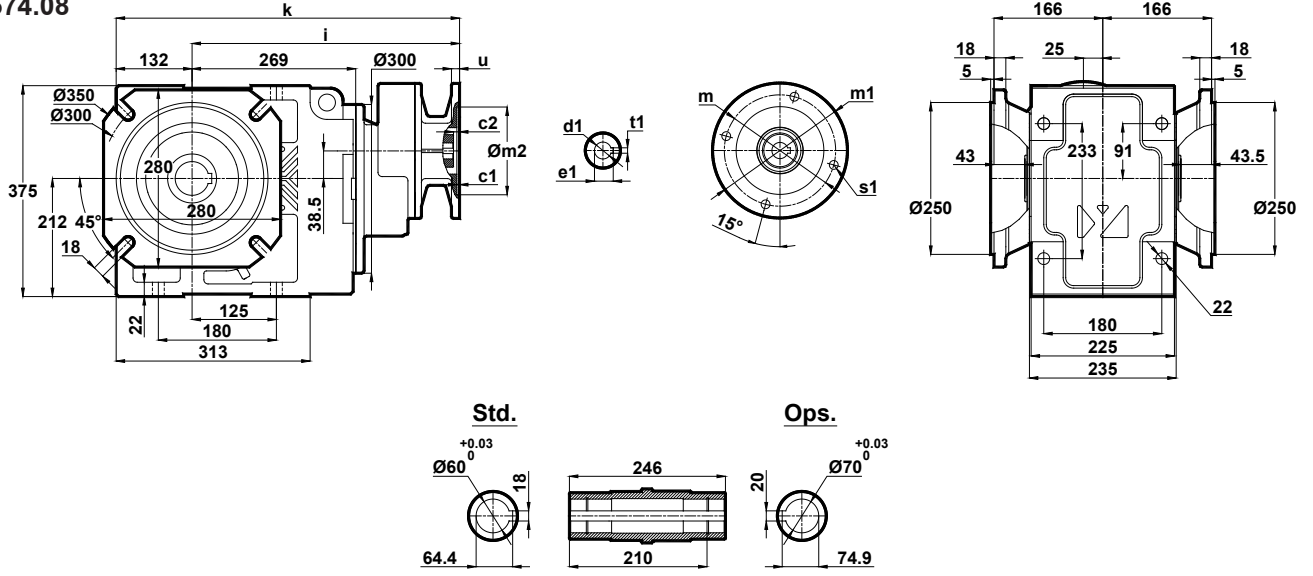

	c1	c2	s1	m	m1	m2	i	u	k	d1	t1	e1
71/B5	4	9	11	130	160	110	422	12	554	14	5	16.3
80/B5	4	9	13	165	200	130	422	12	554	19	6	21.8
90/B5	4	9	13	165	200	130	422	12	554	24	8	27.3
100/B5	4.5	9	15	215	250	180	439	15	571	28	8	31.3

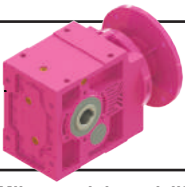

# Ölçü Sayfaları

## Dimension Pages

### Abmessungsseiten

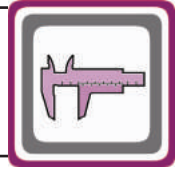

-Mil ucu çekirme deliği DIN 332 sayfa 2 / Tapped center hole to DIN 332, sheet 2 / Zentrierung mit gewinde DIN 332, Blatt 2

KN575.00  
KN576.00

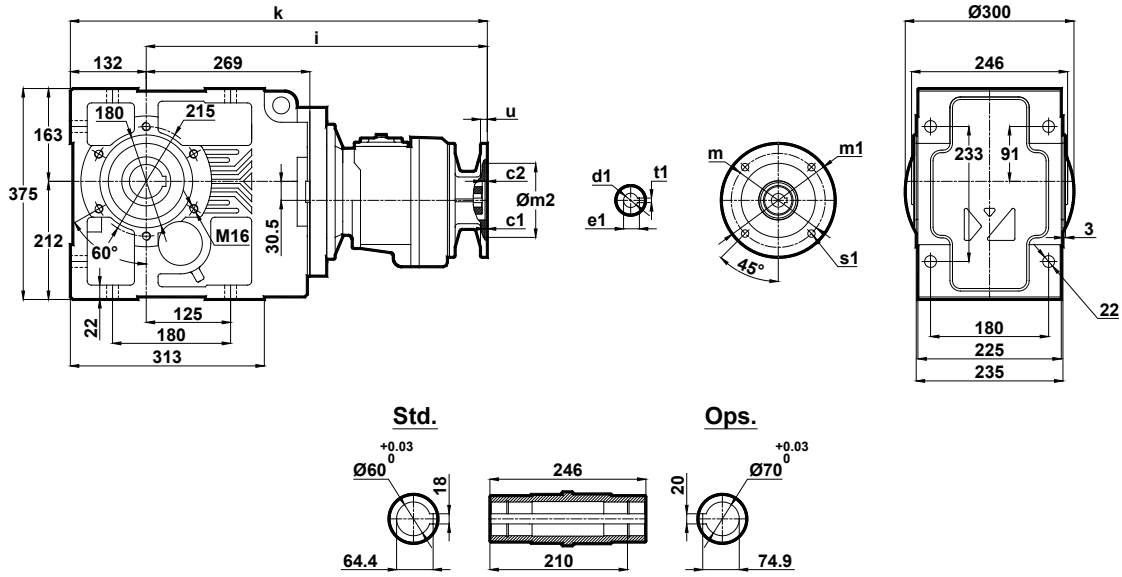

	c1	c2	s1	m	m1	m2	i	u	k	d1	t1	e1
63/B5	4	8	9	115	140	95	552	12	684	11	4	12.8
71/B5	4	8.5	11	130	160	110	523	12	655	14	5	16.3
80/B5	4	5	13	165	200	130	552	12	684	19	6	21.8

KN575.01  
KN576.01

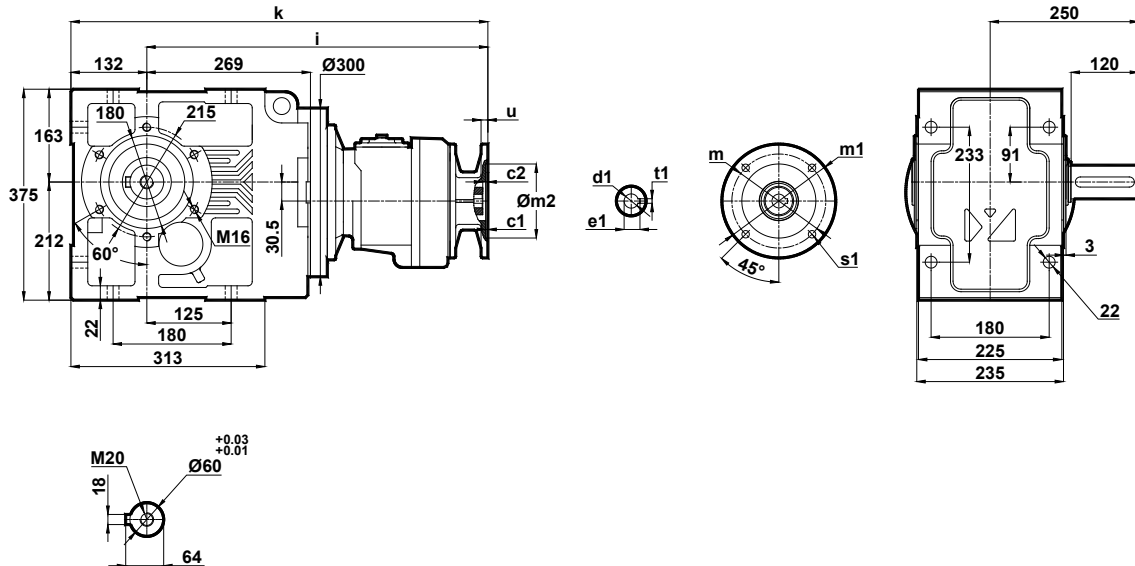

	c1	c2	s1	m	m1	m2	i	u	k	d1	t1	e1
63/B5	4	8	9	115	140	95	552	12	684	11	4	12.8
71/B5	4	8.5	11	130	160	110	523	12	655	14	5	16.3
80/B5	4	5	13	165	200	130	552	12	684	19	6	21.8

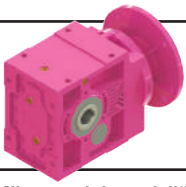

# Ölçü Sayfaları Dimension Pages Abmessungsseiten

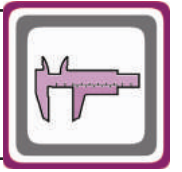

-Mil ucu çekirme deliği DIN 332 sayfa 2 / Tapped center hole to DIN 332, sheet 2 / Zentrierung mit gewinde DIN 332, Blatt 2

KN575.02  
KN576.02

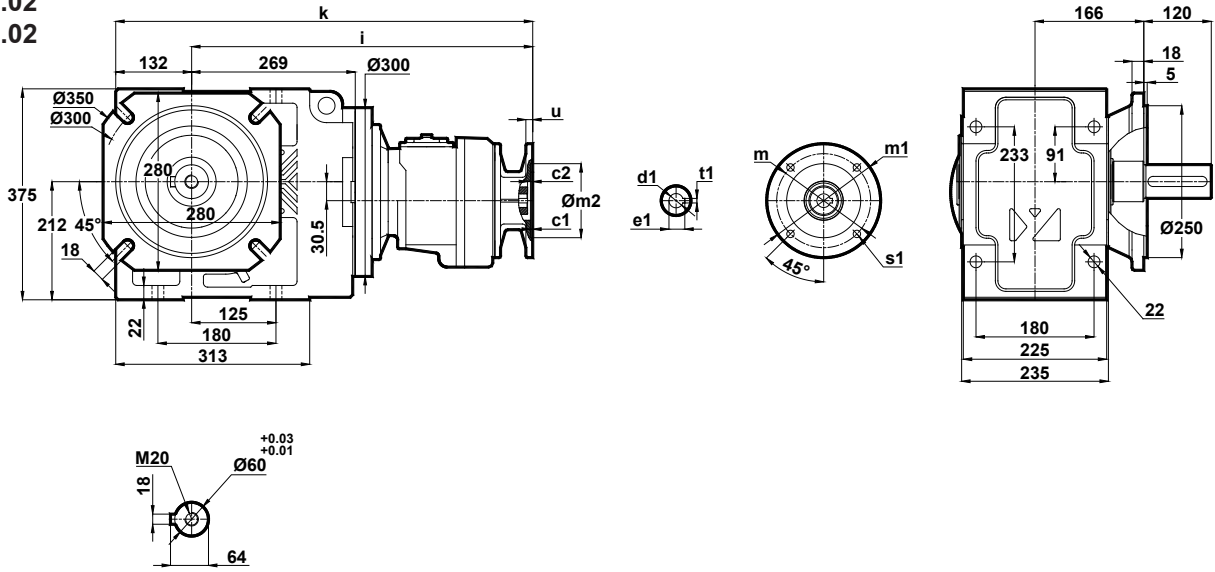

	c1	c2	s1	m	m1	m2	i	u	k	d1	t1	e1
63/B5	4	8	9	115	140	95	552	12	684	11	4	12.8
71/B5	4	8.5	11	130	160	110	523	12	655	14	5	16.3
80/B5	4	5	13	165	200	130	552	12	684	19	6	21.8

KN575.03  
KN576.03

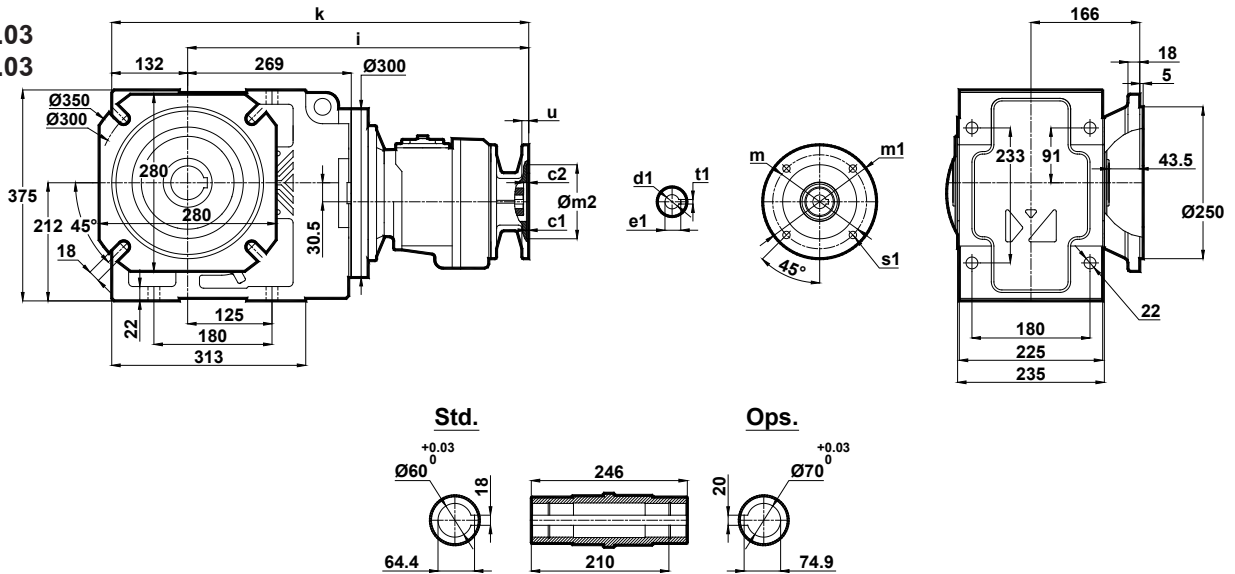

	c1	c2	s1	m	m1	m2	i	u	k	d1	t1	e1
63/B5	4	8	9	115	140	95	552	12	684	11	4	12.8
71/B5	4	8.5	11	130	160	110	523	12	655	14	5	16.3
80/B5	4	5	13	165	200	130	552	12	684	19	6	21.8

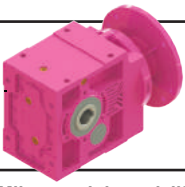

# Ölçü Sayfaları Dimension Pages Abmessungsseiten

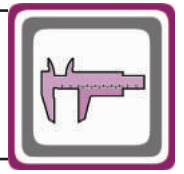

-Mil ucu çektirme deliği DIN 332 sayfa 2 / Tapped center hole to DIN 332, sheet 2 / Zentrierung mit gewinde DIN 332, Blatt 2

KN575.04  
KN576.04

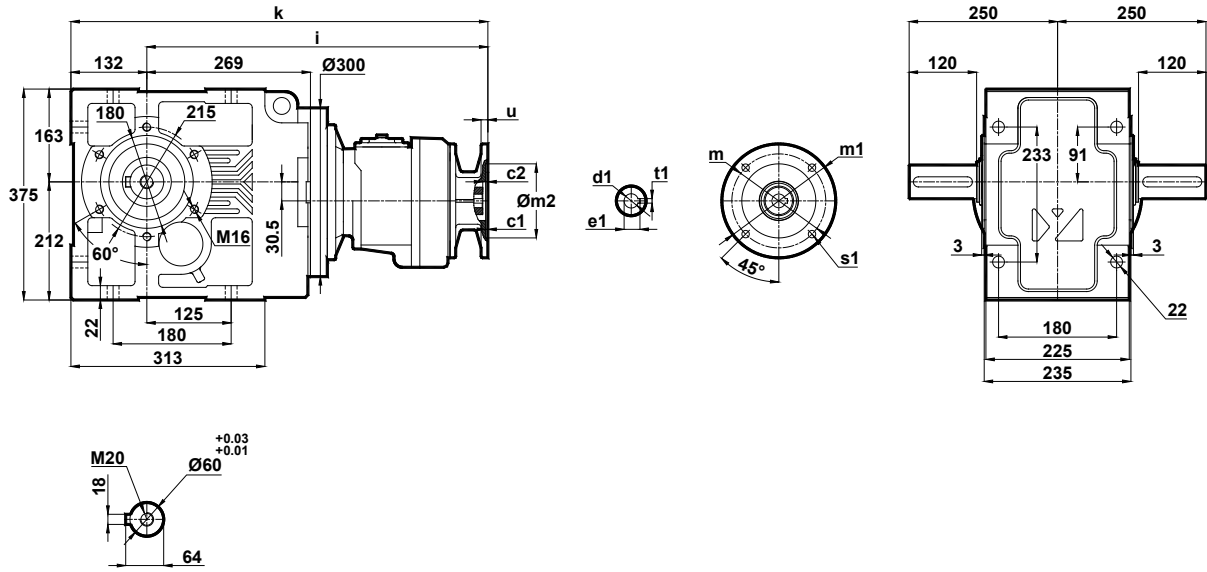

	c1	c2	s1	m	m1	m2	i	u	k	d1	t1	e1
63/B5	4	8	9	115	140	95	552	12	684	11	4	12.8
71/B5	4	8.5	11	130	160	110	523	12	655	14	5	16.3
80/B5	4	5	13	165	200	130	552	12	684	19	6	21.8

KN575.05  
KN576.05

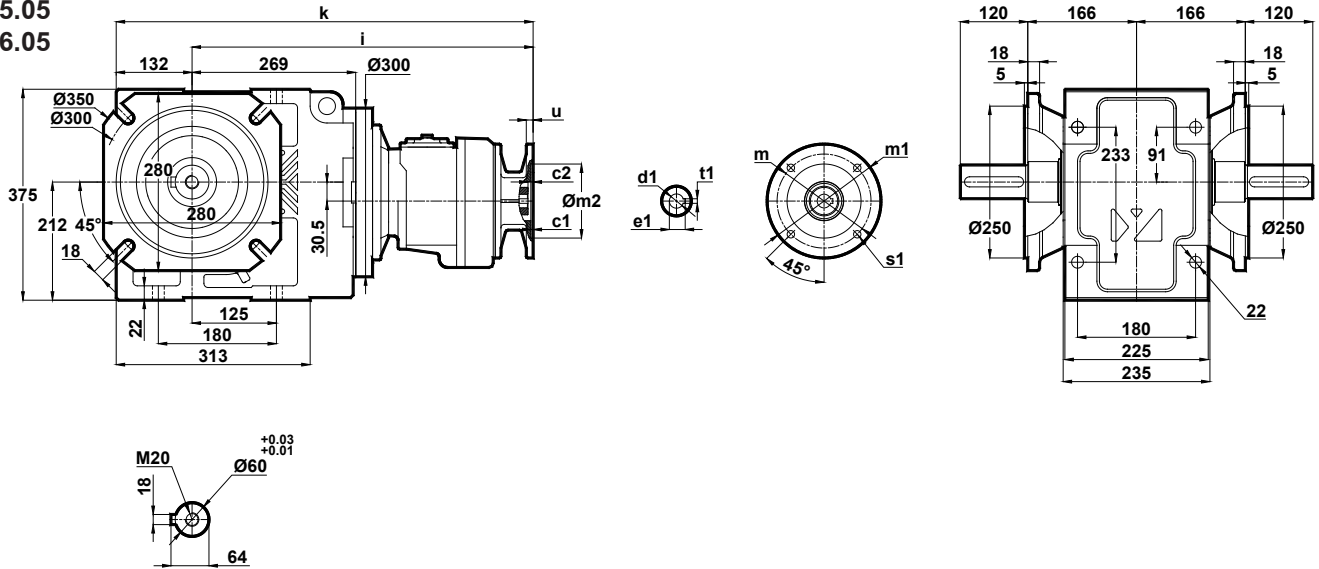

	c1	c2	s1	m	m1	m2	i	u	k	d1	t1	e1
63/B5	4	8	9	115	140	95	552	12	684	11	4	12.8
71/B5	4	8.5	11	130	160	110	523	12	655	14	5	16.3
80/B5	4	5	13	165	200	130	552	12	684	19	6	21.8

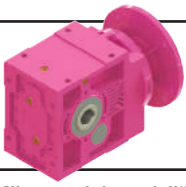

# Ölçü Sayfaları

## Dimension Pages

### Abmessungsseiten

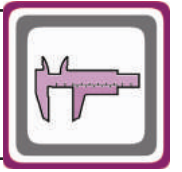

-Mil ucu çektirme deliği DIN 332 sayfa 2 / Tapped center hole to DIN 332, sheet 2 / Zentrierung mit gewinde DIN 332, Blatt 2

KN575.08  
KN576.08

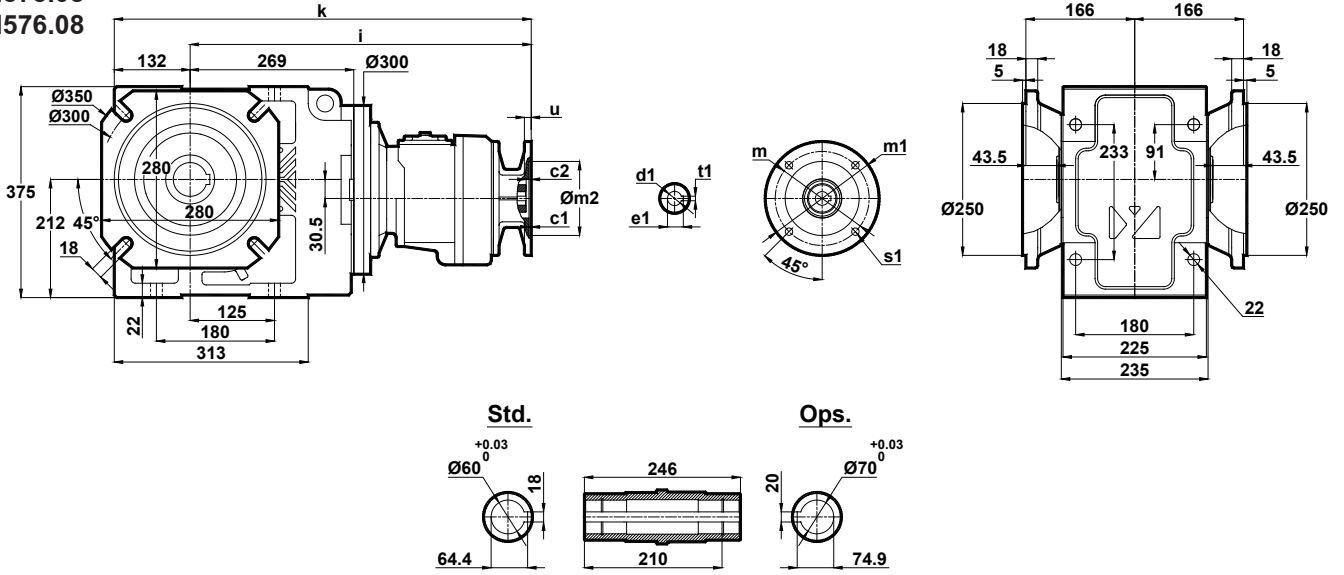

	c1	c2	s1	m	m1	m2	i	u	k	d1	t1	e1
63/B5	4	8	9	115	140	95	552	12	684	11	4	12.8
71/B5	4	8.5	11	130	160	110	523	12	655	14	5	16.3
80/B5	4	5	13	165	200	130	552	12	684	19	6	21.8

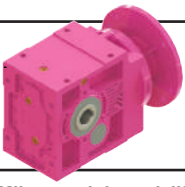

# Ölçü Sayfaları Dimension Pages Abmessungsseiten

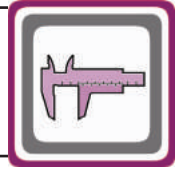

-Mil ucu çekirme deliği DIN 332 sayfa 2 / Tapped center hole to DIN 332, sheet 2 / Zentrierung mit gewinde DIN 332, Blatt 2

## KN673.00

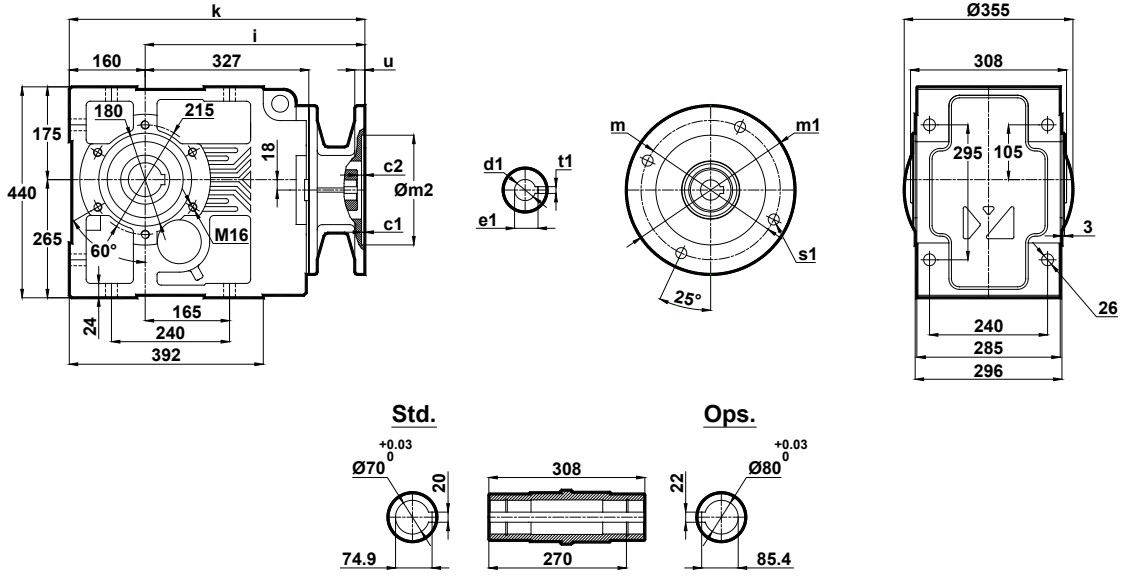

	c1	c2	s1	m	m1	m2	i	u	k	d1	t1	e1
100/B5	4.5	14.5	15	215	250	180	396	15	556	28	8	31.3
112/B5	4.5	14.5	15	215	250	180	396	15	556	28	8	31.3
132/B5	4.5	9	15	265	300	230	411	15	571	38	10	41.3
160/B5	5.5	10	19	300	350	250	486	20	646	42	12	45.3
180/B5	5.5	10	19	300	350	250	486	20	646	48	14	51.8
200/B5	5.5	10	19	350	400	300	506	22	743	55	16	59.3
225/B5	5.5	10	19	400	450	350	559	24	796	60	18	64.4

## KN673.01

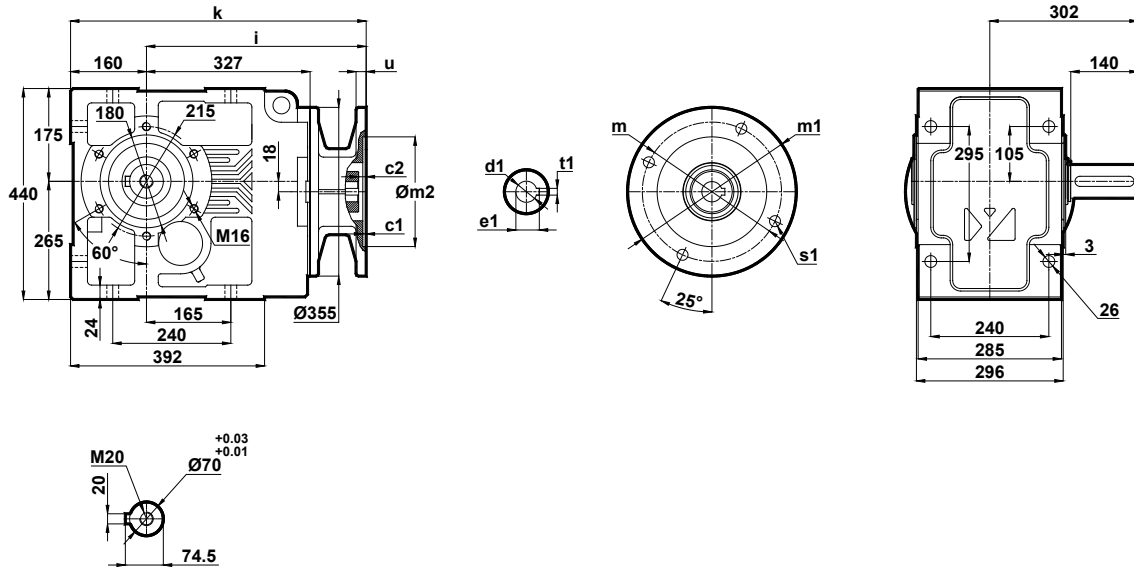

	c1	c2	s1	m	m1	m2	i	u	k	d1	t1	e1
100/B5	4.5	14.5	15	215	250	180	396	15	556	28	8	31.3
112/B5	4.5	14.5	15	215	250	180	396	15	556	28	8	31.3
132/B5	4.5	9	15	265	300	230	411	15	571	38	10	41.3
160/B5	5.5	10	19	300	350	250	486	20	646	42	12	45.3
180/B5	5.5	10	19	300	350	250	486	20	646	48	14	51.8
200/B5	5.5	10	19	350	400	300	506	22	743	55	16	59.3
225/B5	5.5	10	19	400	450	350	559	24	796	60	18	64.4

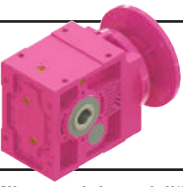

# Ölçü Sayfaları Dimension Pages Abmessungsseiten

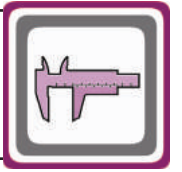

-Mil ucu çektirme deliği DIN 332 sayfa 2 / Tapped center hole to DIN 332, sheet 2 / Zentrierung mit gewinde DIN 332, Blatt 2

## KN673.02

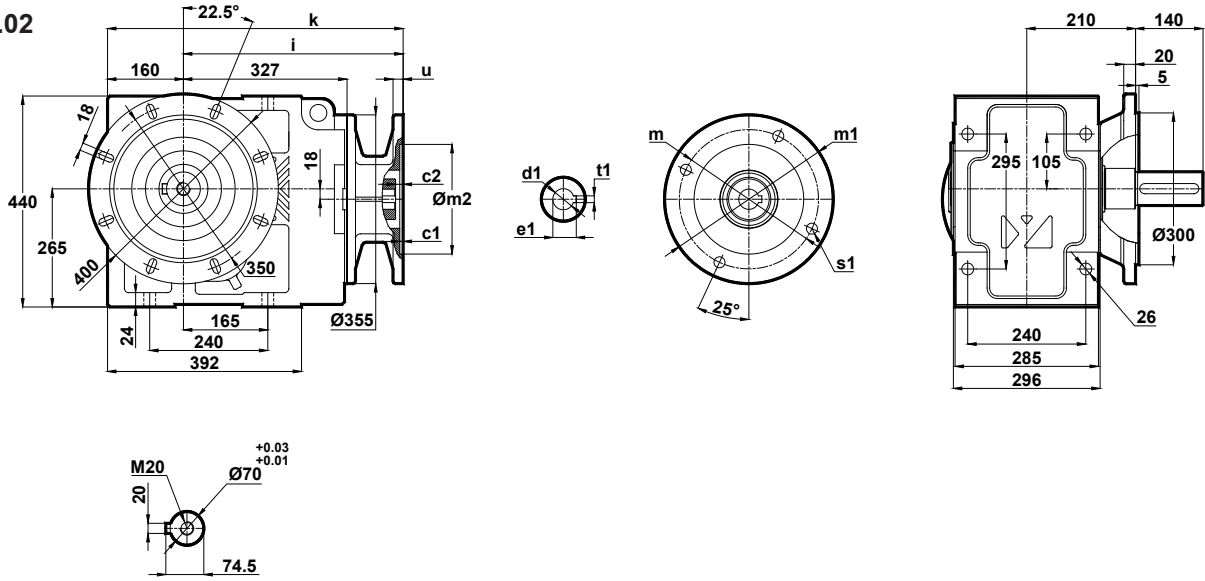

	c1	c2	s1	m	m1	m2	i	u	k	d1	t1	e1
100/B5	4.5	14.5	15	215	250	180	396	15	556	28	8	31.3
112/B5	4.5	14.5	15	215	250	180	396	15	556	28	8	31.3
132/B5	4.5	9	15	265	300	230	411	15	571	38	10	41.3
160/B5	5.5	10	19	300	350	250	486	20	646	42	12	45.3
180/B5	5.5	10	19	300	350	250	486	20	646	48	14	51.8
200/B5	5.5	10	19	350	400	300	506	22	743	55	16	59.3
225/B5	5.5	10	19	400	450	350	559	24	796	60	18	64.4

## KN673.03

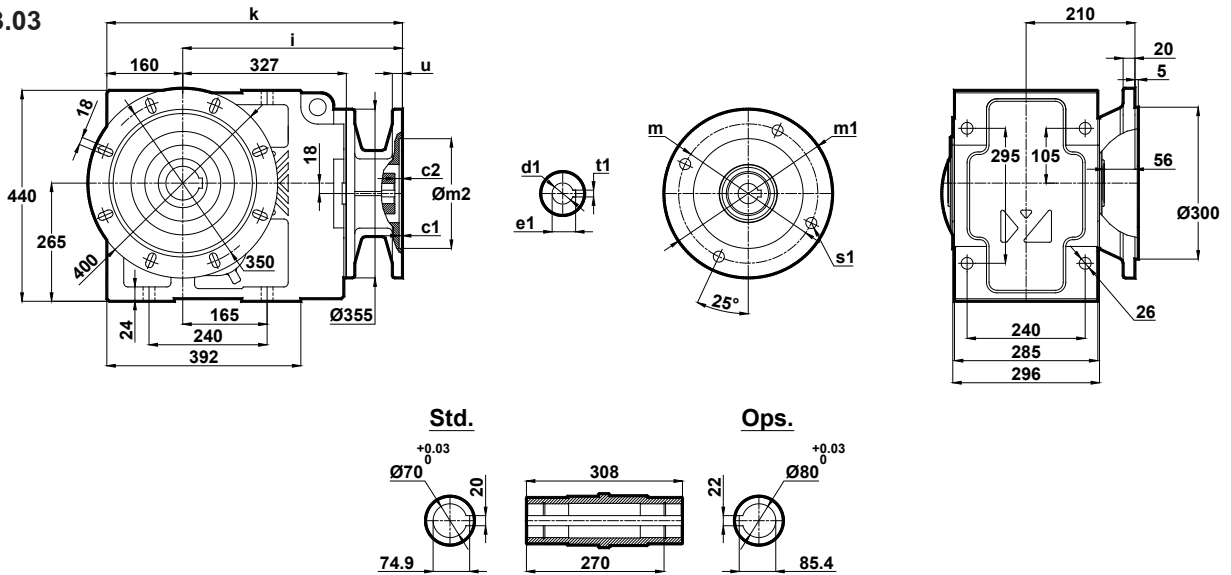

	c1	c2	s1	m	m1	m2	i	u	k	d1	t1	e1
100/B5	4.5	14.5	15	215	250	180	396	15	556	28	8	31.3
112/B5	4.5	14.5	15	215	250	180	396	15	556	28	8	31.3
132/B5	4.5	9	15	265	300	230	411	15	571	38	10	41.3
160/B5	5.5	10	19	300	350	250	486	20	646	42	12	45.3
180/B5	5.5	10	19	300	350	250	486	20	646	48	14	51.8
200/B5	5.5	10	19	350	400	300	506	22	743	55	16	59.3
225/B5	5.5	10	19	400	450	350	559	24	796	60	18	64.4

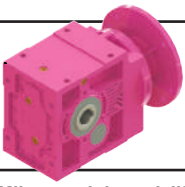

# Ölçü Sayfaları Dimension Pages Abmessungsseiten

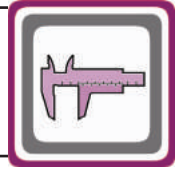

-Mil ucu çekirme deliği DIN 332 sayfa 2 / Tapped center hole to DIN 332, sheet 2 / Zentrierung mit gewinde DIN 332, Blatt 2

## KN673.04

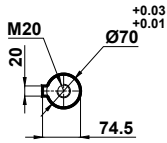
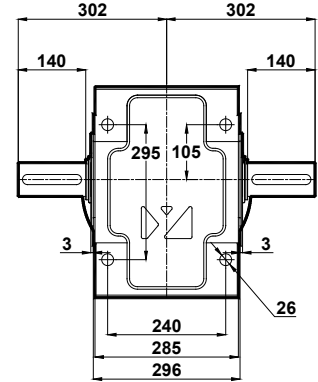
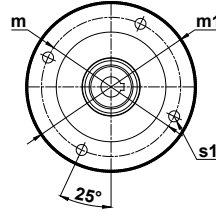
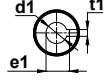
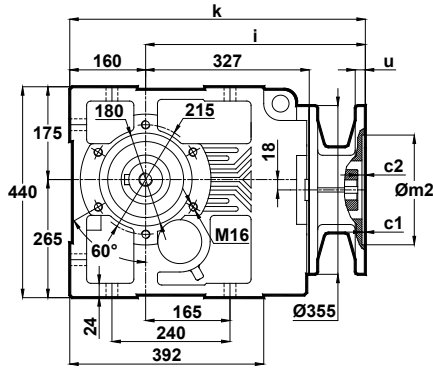

	c1	c2	s1	m	m1	m2	i	u	k	d1	t1	e1
100/B5	4.5	14.5	15	215	250	180	396	15	556	28	8	31.3
112/B5	4.5	14.5	15	215	250	180	396	15	556	28	8	31.3
132/B5	4.5	9	15	265	300	230	411	15	571	38	10	41.3
160/B5	5.5	10	19	300	350	250	486	20	646	42	12	45.3
180/B5	5.5	10	19	300	350	250	486	20	646	48	14	51.8
200/B5	5.5	10	19	350	400	300	506	22	743	55	16	59.3
225/B5	5.5	10	19	400	450	350	559	24	796	60	18	64.4

## KN673.05

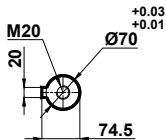
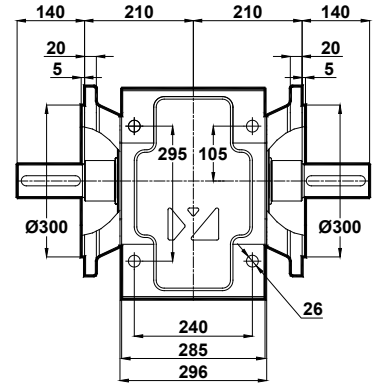
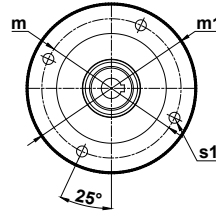
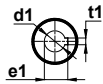
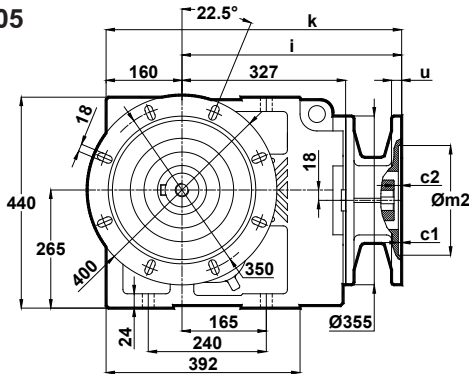

	c1	c2	s1	m	m1	m2	i	u	k	d1	t1	e1
100/B5	4.5	14.5	15	215	250	180	396	15	556	28	8	31.3
112/B5	4.5	14.5	15	215	250	180	396	15	556	28	8	31.3
132/B5	4.5	9	15	265	300	230	411	15	571	38	10	41.3
160/B5	5.5	10	19	300	350	250	486	20	646	42	12	45.3
180/B5	5.5	10	19	300	350	250	486	20	646	48	14	51.8
200/B5	5.5	10	19	350	400	300	506	22	743	55	16	59.3
225/B5	5.5	10	19	400	450	350	559	24	796	60	18	64.4

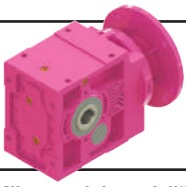

# Ölçü Sayfaları

## Dimension Pages

### Abmessungsseiten

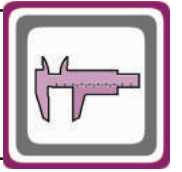

-Mil ucu çekirme deliği DIN 332 sayfa 2 / Tapped center hole to DIN 332, sheet 2 / Zentrierung mit gewinde DIN 332, Blatt 2

KN673.08

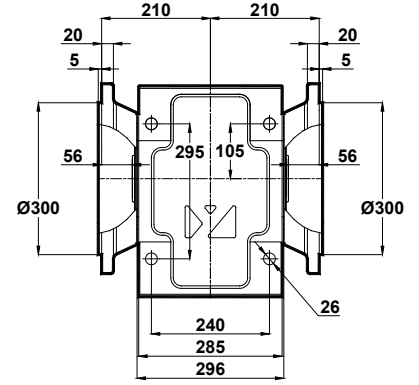
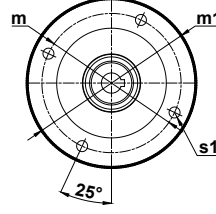
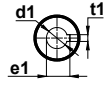
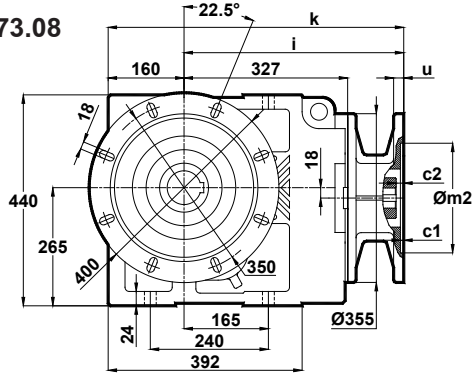

Std.

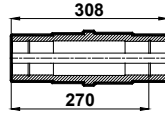
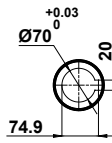

Ops.

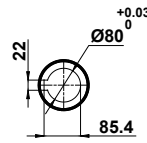

	c1	c2	s1	m	m1	m2	i	u	k	d1	t1	e1
100/B5	4.5	14.5	15	215	250	180	396	15	556	28	8	31.3
112/B5	4.5	14.5	15	215	250	180	396	15	556	28	8	31.3
132/B5	4.5	9	15	265	300	230	411	15	571	38	10	41.3
160/B5	5.5	10	19	300	350	250	486	20	646	42	12	45.3
180/B5	5.5	10	19	300	350	250	486	20	646	48	14	51.8
200/B5	5.5	10	19	350	400	300	506	22	743	55	16	59.3
225/B5	5.5	10	19	400	450	350	559	24	796	60	18	64.4

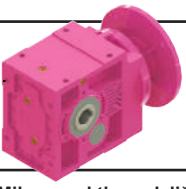

# Ölçü Sayfaları Dimension Pages Abmessungsseiten

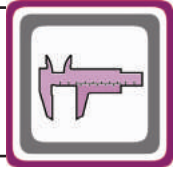

-Mil ucu çekirme deliği DIN 332 sayfa 2 / Tapped center hole to DIN 332, sheet 2 / Zentrierung mit gewinde DIN 332, Blatt 2

## KN674.00

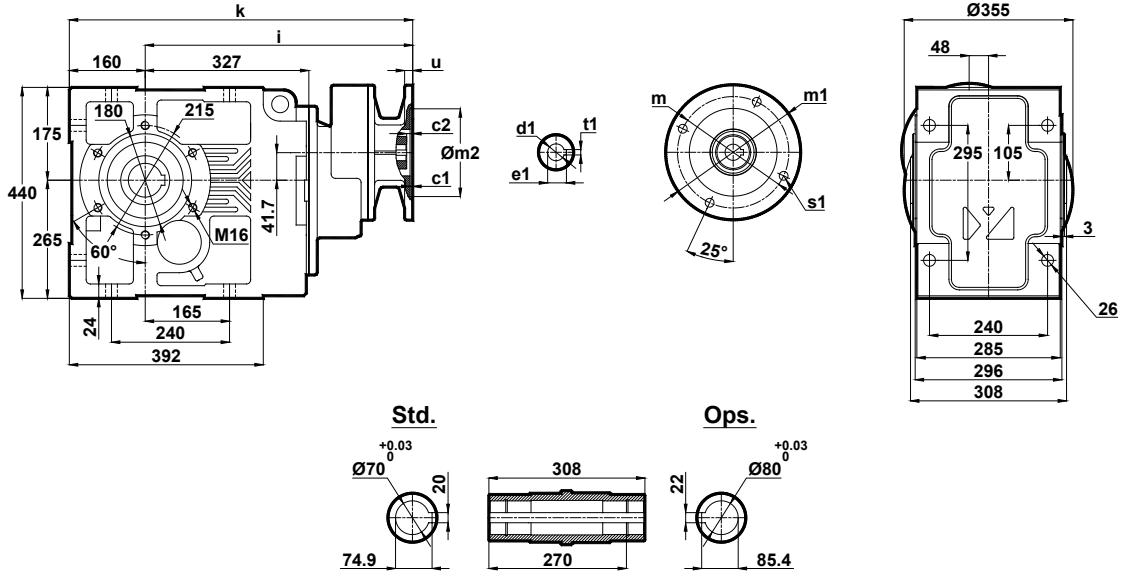

	c1	c2	s1	m	m1	m2	i	u	k	d1	t1	e1
80/B5	4	5	12	162	200	130	486	12	646	19	6	21.8
90/B5	4	5	13	165	200	130	486	12	646	24	8	27.3
100/B5	4.5	9	15	215	250	180	504	15	664	28	8	31.3

## KN674.01

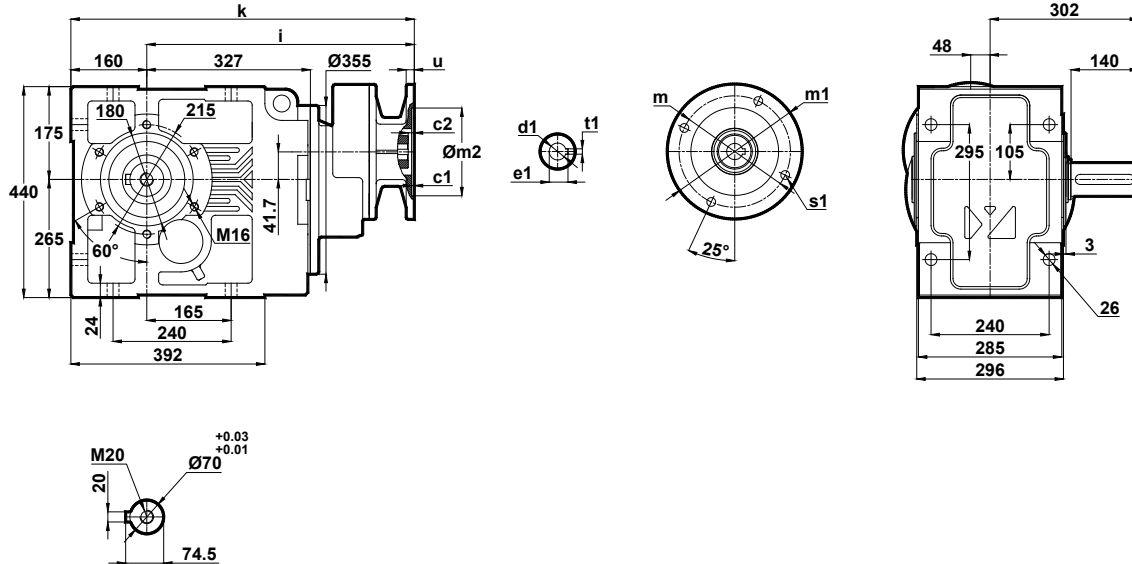

	c1	c2	s1	m	m1	m2	i	u	k	d1	t1	e1
80/B5	4	5	12	162	200	130	486	12	646	19	6	21.8
90/B5	4	5	13	165	200	130	486	12	646	24	8	27.3
100/B5	4.5	9	15	215	250	180	504	15	664	28	8	31.3

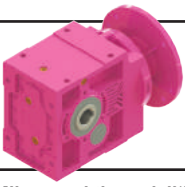

# Ölçü Sayfaları

## Dimension Pages

### Abmessungsseiten

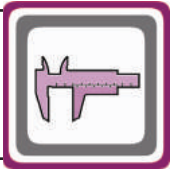

-Mil ucu çekirme deliği DIN 332 sayfa 2 / Tapped center hole to DIN 332, sheet 2 / Zentrierung mit gewinde DIN 332, Blatt 2

#### KN674.02

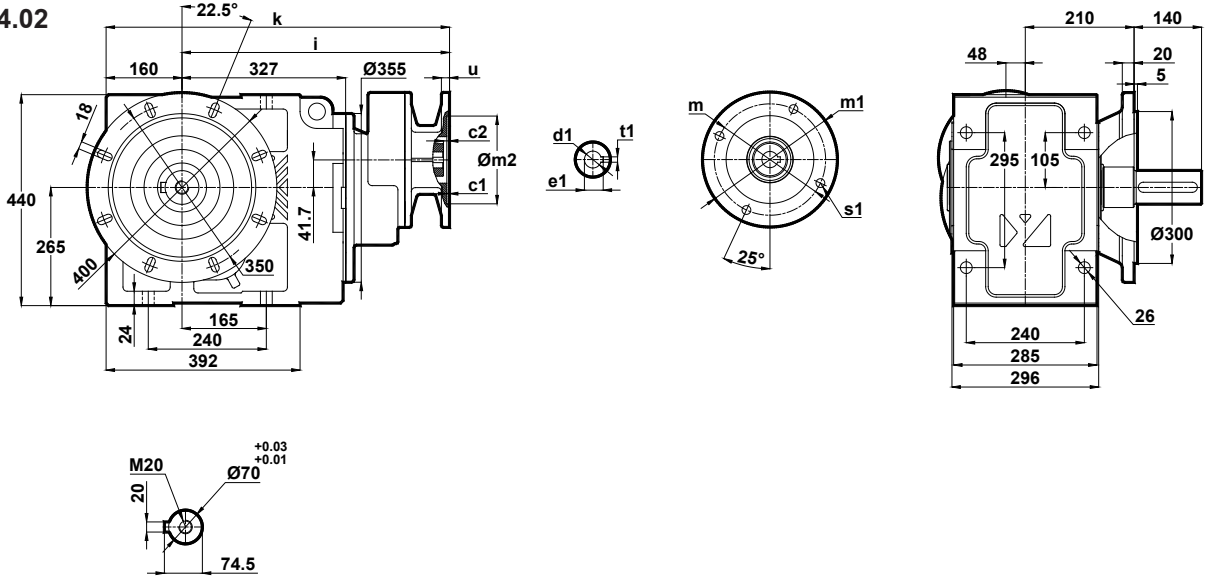

	c1	c2	s1	m	m1	m2	i	u	k	d1	t1	e1
80/B5	4	5	12	162	200	130	486	12	646	19	6	21.8
90/B5	4	5	13	165	200	130	486	12	646	24	8	27.3
100/B5	4.5	9	15	215	250	180	504	15	664	28	8	31.3

#### KN674.03

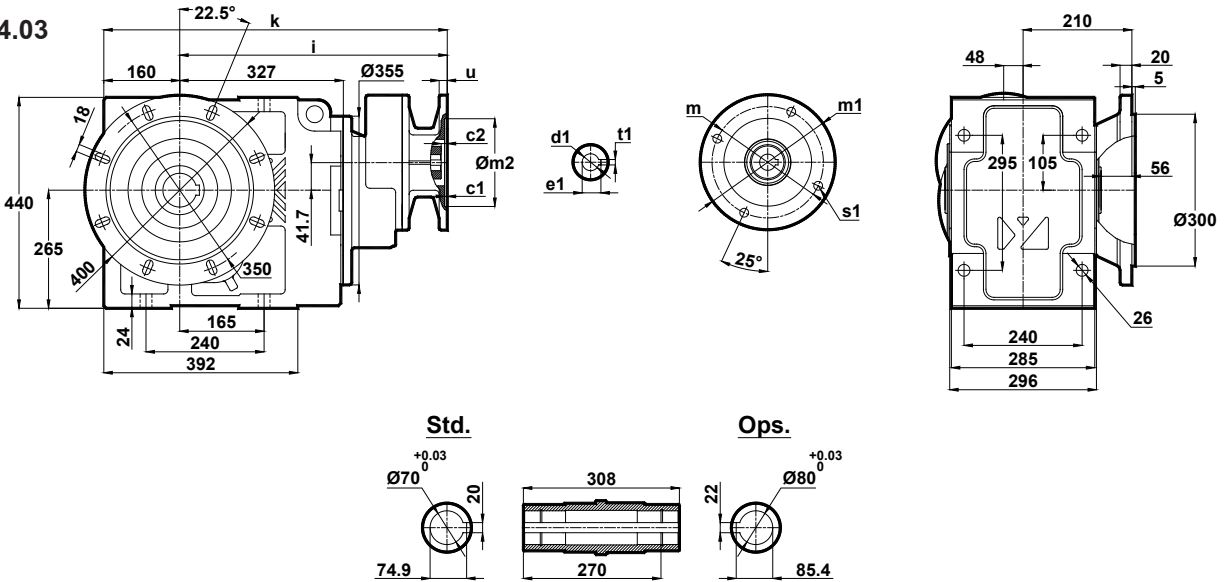

	c1	c2	s1	m	m1	m2	i	u	k	d1	t1	e1
80/B5	4	5	12	162	200	130	486	12	646	19	6	21.8
90/B5	4	5	13	165	200	130	486	12	646	24	8	27.3
100/B5	4.5	9	15	215	250	180	504	15	664	28	8	31.3

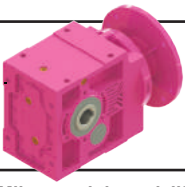

# Ölçü Sayfaları Dimension Pages Abmessungenseiten

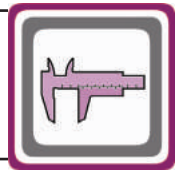

-Mil ucu çektirme deliği DIN 332 sayfa 2 / Tapped center hole to DIN 332, sheet 2 / Zentrierung mit gewinde DIN 332, Blatt 2

## KN674.04

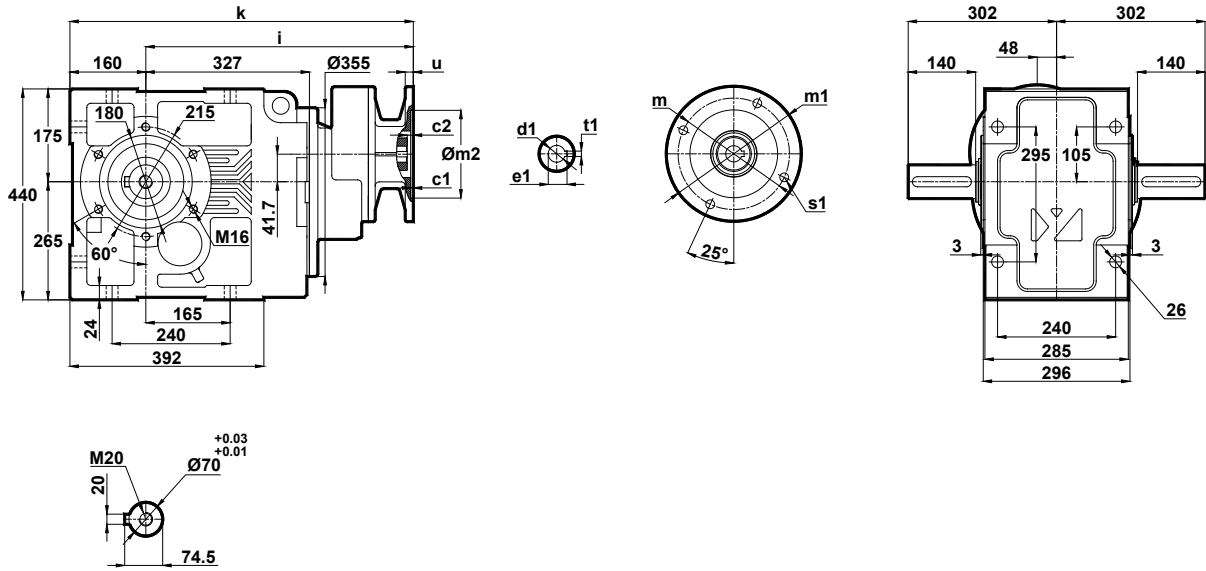

	c1	c2	s1	m	m1	m2	i	u	k	d1	t1	e1
80/B5	4	5	12	162	200	130	486	12	646	19	6	21.8
90/B5	4	5	13	165	200	130	486	12	646	24	8	27.3
100/B5	4.5	9	15	215	250	180	504	15	664	28	8	31.3

## KN674.05

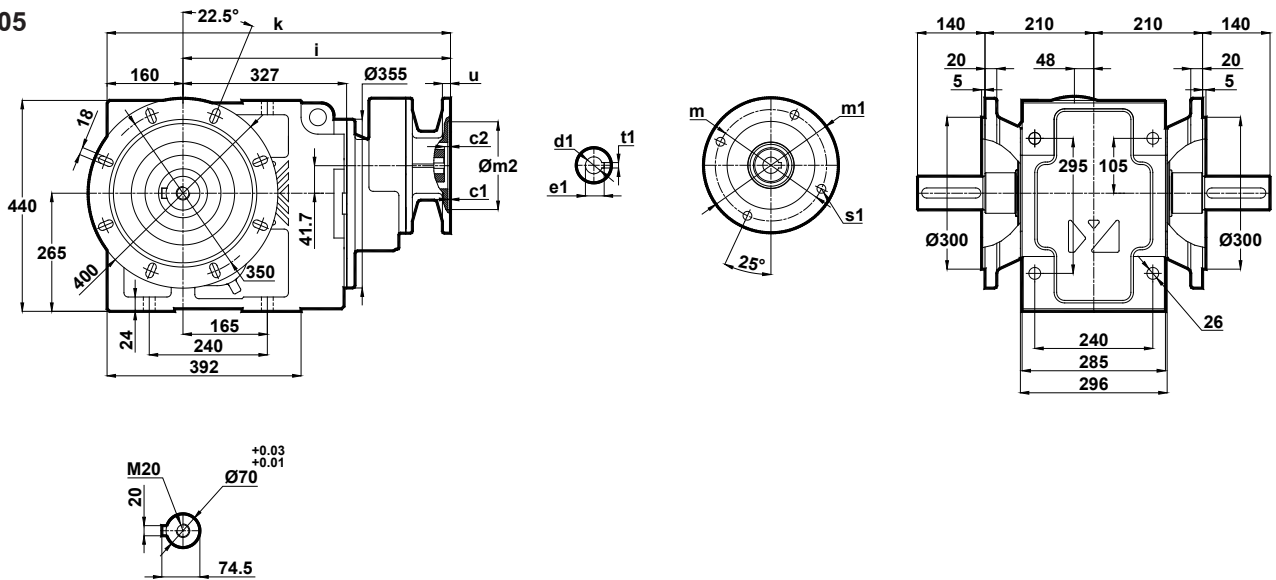

	c1	c2	s1	m	m1	m2	i	u	k	d1	t1	e1
80/B5	4	5	12	162	200	130	486	12	646	19	6	21.8
90/B5	4	5	13	165	200	130	486	12	646	24	8	27.3
100/B5	4.5	9	15	215	250	180	504	15	664	28	8	31.3

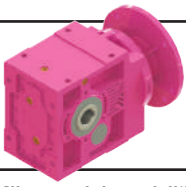

# Ölçü Sayfaları

## Dimension Pages

### Abmessungsseiten

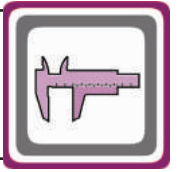

-Mil ucu çekirme deliği DIN 332 sayfa 2 / Tapped center hole to DIN 332, sheet 2 / Zentrierung mit gewinde DIN 332, Blatt 2

KN674.08

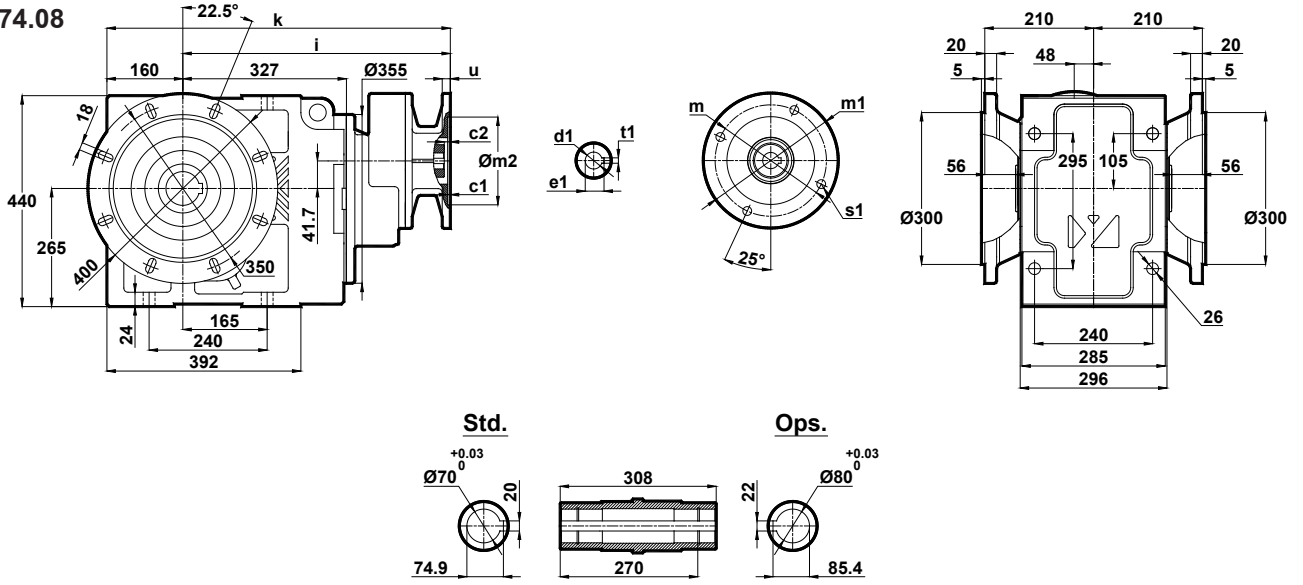

	c1	c2	s1	m	m1	m2	i	u	k	d1	t1	e1
80/B5	4	5	12	162	200	130	486	12	646	19	6	21.8
90/B5	4	5	13	165	200	130	486	12	646	24	8	27.3
100/B5	4.5	9	15	215	250	180	504	15	664	28	8	31.3

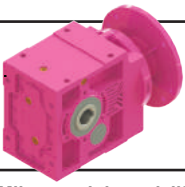

# Ölçü Sayfaları

## Dimension Pages

### Abmessungsseiten

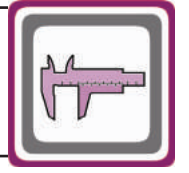

-Mil ucu çekirme deliği DIN 332 sayfa 2 / Tapped center hole to DIN 332, sheet 2 / Zentrierung mit gewinde DIN 332, Blatt 2

KN675.00  
KN676.00

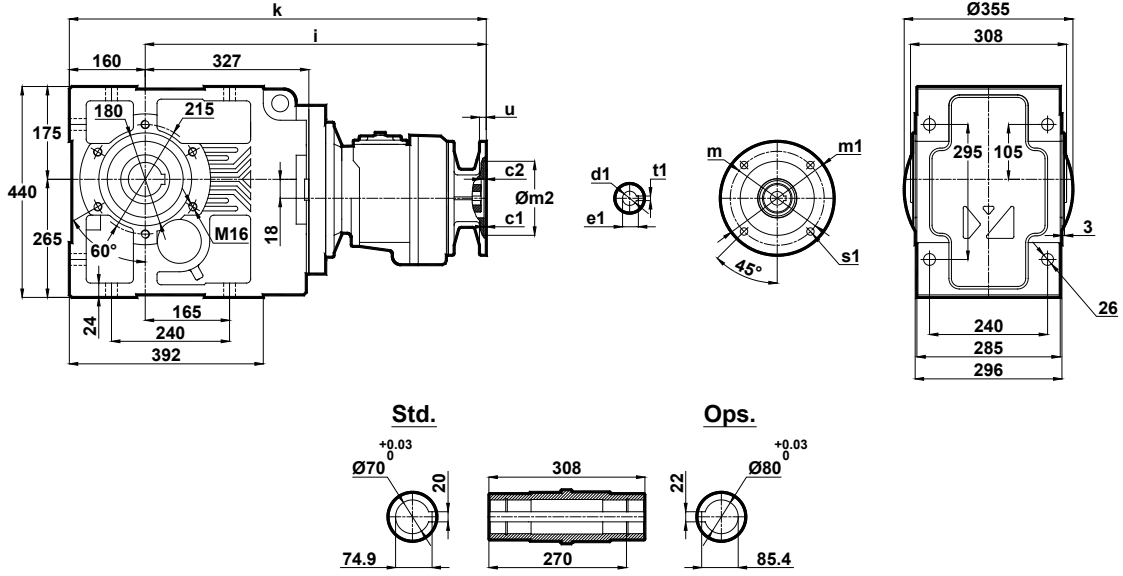

	c1	c2	s1	m	m1	m2	i	u	k	d1	t1	e1
71/B5	4	9	11	130	160	110	637	12	797	14	5	16.3
80/B5	4	9	13	165	200	130	637	12	797	19	6	21.8
90/B5	4	9	13	165	200	130	637	12	797	24	8	27.3

KN675.01  
KN676.01

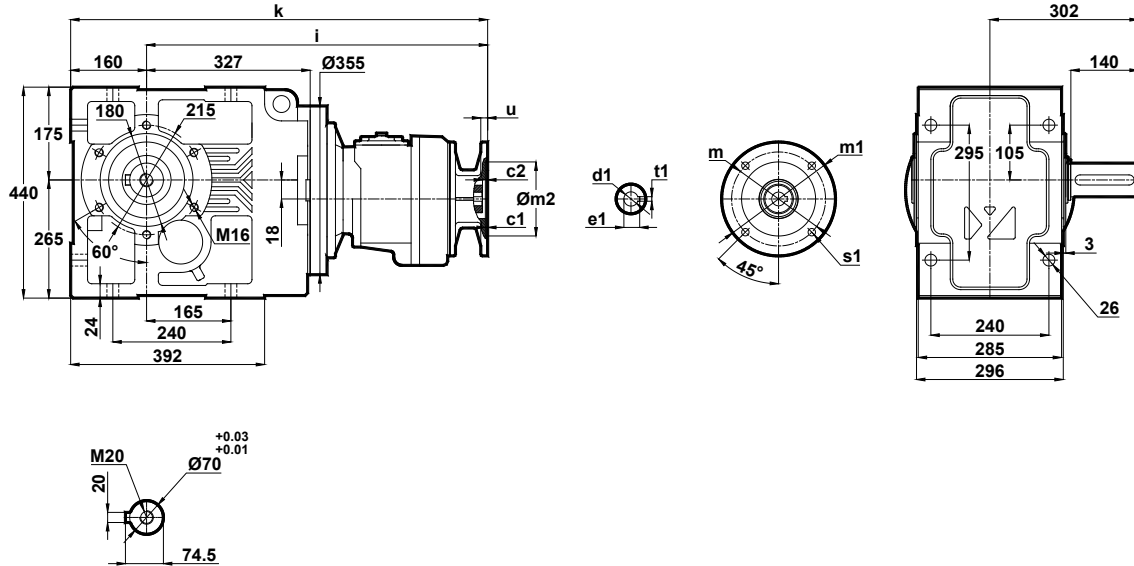

	c1	c2	s1	m	m1	m2	i	u	k	d1	t1	e1
71/B5	4	9	11	130	160	110	637	12	797	14	5	16.3
80/B5	4	9	13	165	200	130	637	12	797	19	6	21.8
90/B5	4	9	13	165	200	130	637	12	797	24	8	27.3

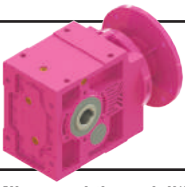

# Ölçü Sayfaları

## Dimension Pages

### Abmessungsseiten

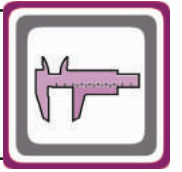

-Mil ucu çekirme deliği DIN 332 sayfa 2 / Tapped center hole to DIN 332, sheet 2 / Zentrierung mit gewinde DIN 332, Blatt 2

KN675.02  
KN676.02

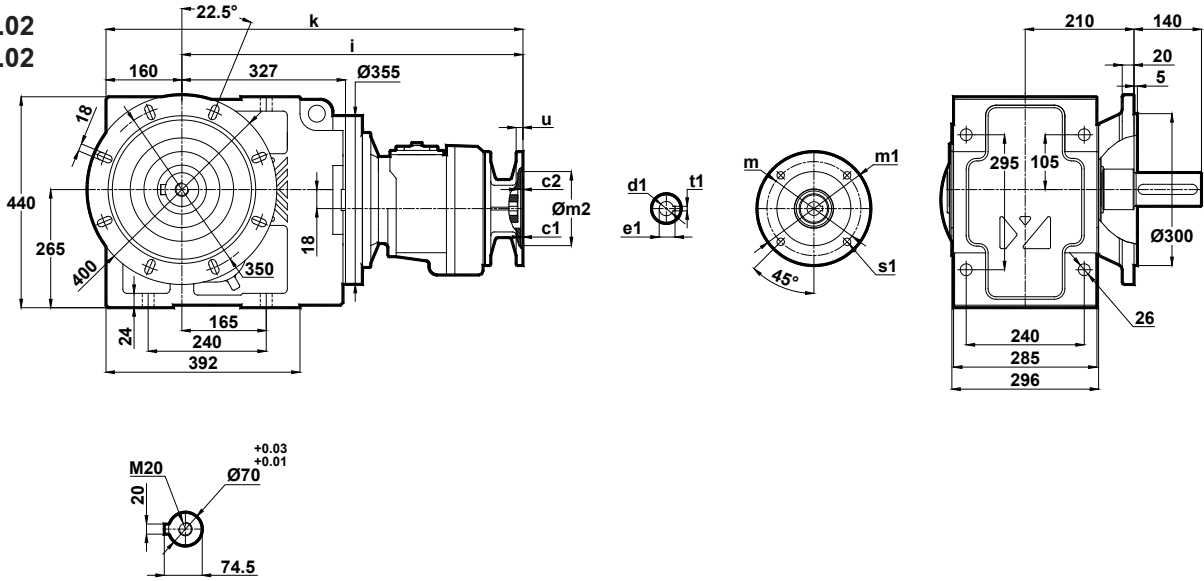

	c1	c2	s1	m	m1	m2	i	u	k	d1	t1	e1
71/B5	4	9	11	130	160	110	637	12	797	14	5	16.3
80/B5	4	9	13	165	200	130	637	12	797	19	6	21.8
90/B5	4	9	13	165	200	130	637	12	797	24	8	27.3

KN675.03  
KN676.03

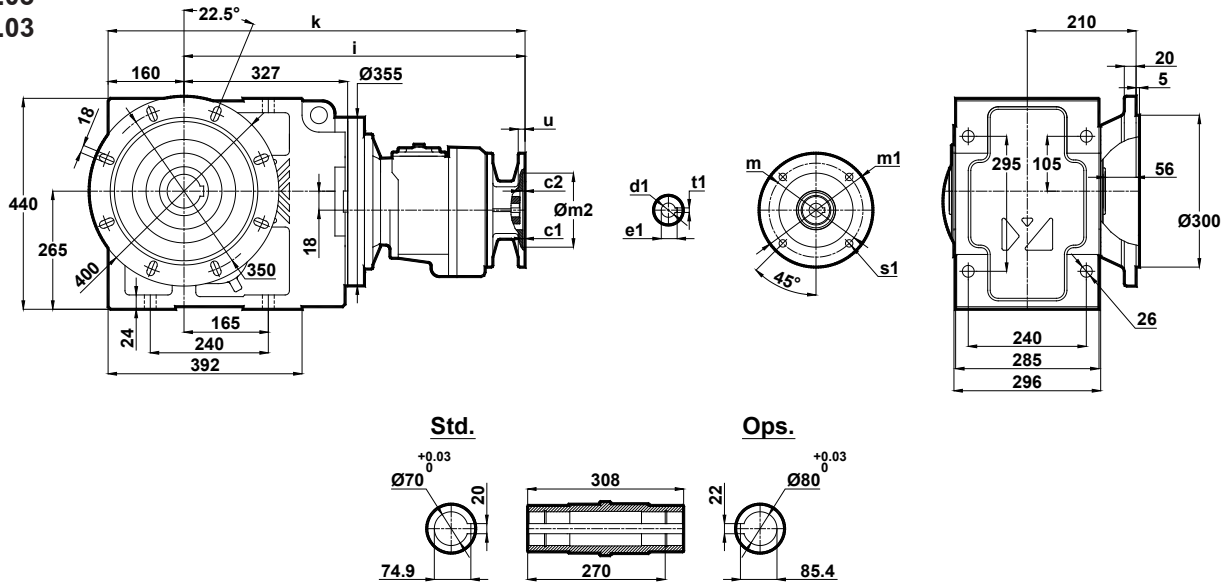

	c1	c2	s1	m	m1	m2	i	u	k	d1	t1	e1
71/B5	4	9	11	130	160	110	637	12	797	14	5	16.3
80/B5	4	9	13	165	200	130	637	12	797	19	6	21.8
90/B5	4	9	13	165	200	130	637	12	797	24	8	27.3

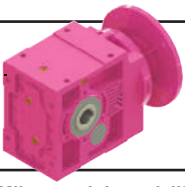

# Ölçü Sayfaları

## Dimension Pages

### Abmessungsseiten

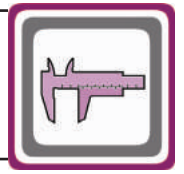

-Mil ucu çekirme deliği DIN 332 sayfa 2 / Tapped center hole to DIN 332, sheet 2 / Zentrierung mit gewinde DIN 332, Blatt 2

KN675.04  
KN676.04

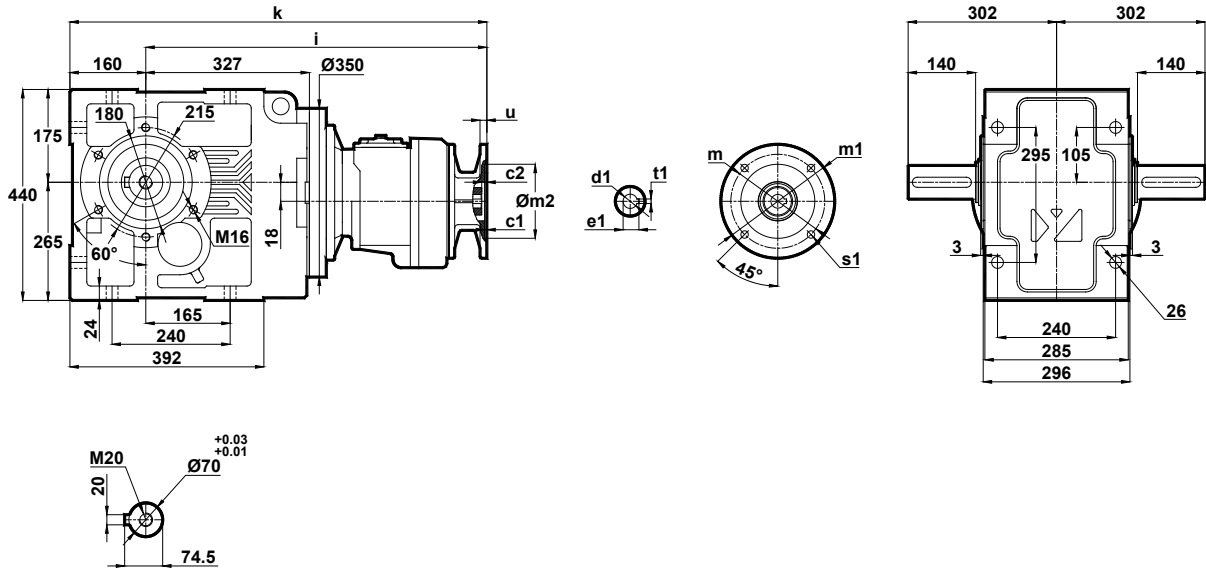

	c1	c2	s1	m	m1	m2	i	u	k	d1	t1	e1
71/B5	4	9	11	130	160	110	637	12	797	14	5	16.3
80/B5	4	9	13	165	200	130	637	12	797	19	6	21.8
90/B5	4	9	13	165	200	130	637	12	797	24	8	27.3

KN675.05  
KN676.05

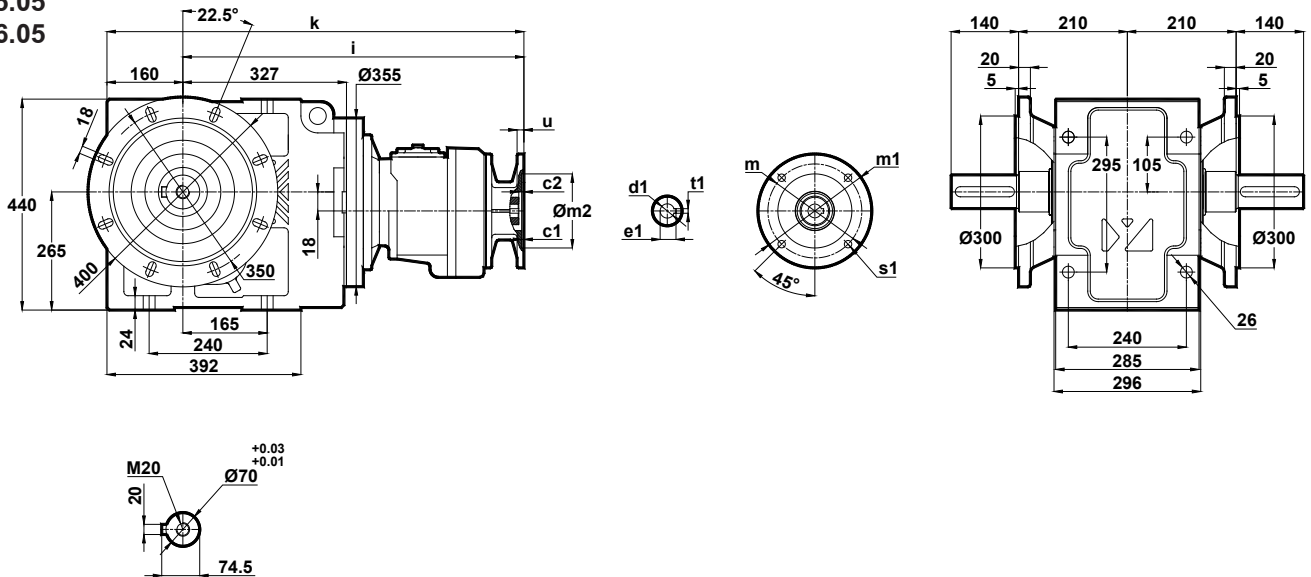

	c1	c2	s1	m	m1	m2	i	u	k	d1	t1	e1
71/B5	4	9	11	130	160	110	637	12	797	14	5	16.3
80/B5	4	9	13	165	200	130	637	12	797	19	6	21.8
90/B5	4	9	13	165	200	130	637	12	797	24	8	27.3

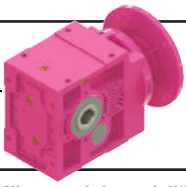

# Ölçü Sayfaları Dimension Pages Abmessungsseiten

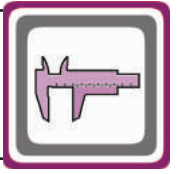

-Mil ucu çekirme deliği DIN 332 sayfa 2 / Tapped center hole to DIN 332, sheet 2 / Zentrierung mit gewinde DIN 332, Blatt 2

KN675.08  
KN676.08

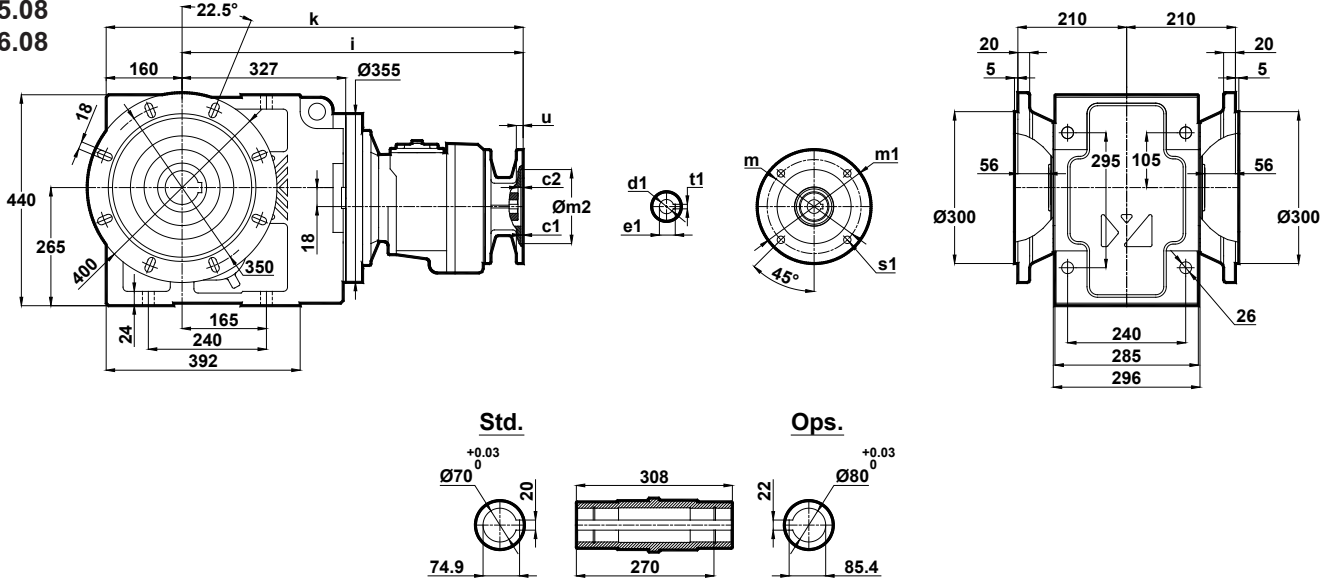

	c1	c2	s1	m	m1	m2	i	u	k	d1	t1	e1
71/B5	4	9	11	130	160	110	637	12	797	14	5	16.3
80/B5	4	9	13	165	200	130	637	12	797	19	6	21.8
90/B5	4	9	13	165	200	130	637	12	797	24	8	27.3

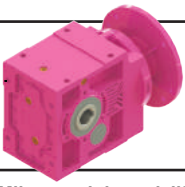

# Ölçü Sayfaları

## Dimension Pages

### Abmessungsseiten

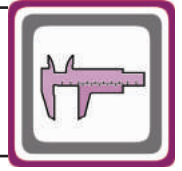

-Mil ucu çekirme deliği DIN 332 sayfa 2 / Tapped center hole to DIN 332, sheet 2 / Zentrierung mit gewinde DIN 332, Blatt 2

#### KN773.00

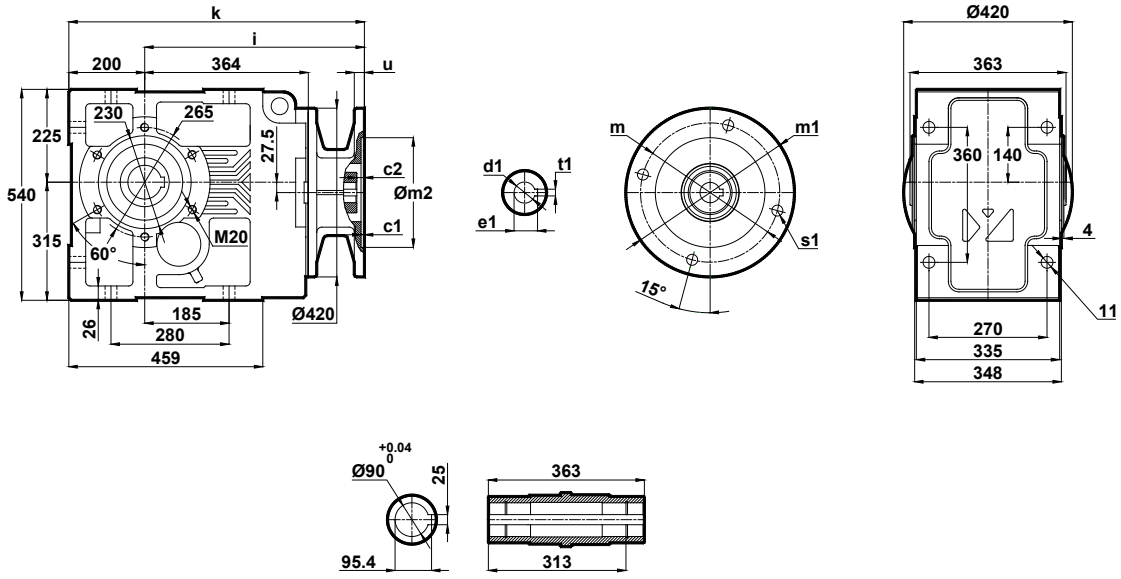

	c1	c2	s1	m	m1	m2	i	u	k	d1	t1	e1
132/B5	4.5	15	15	265	300	230	448	15	648	38	10	41.3
160/B5	5.5	10	19	300	350	250	517	20	717	42	12	45.3
180/B5	5.5	10	19	300	350	250	517	20	717	48	14	51.8
200/B5	5.5	10	19	350	400	300	539	20	739	55	16	59.3
225/B5	5.5	10	19	400	450	350	592	24	792	60	18	64.4
250/B5	5.5	10	19	500	550	450	592	24	792	65	18	69.4

#### KN773.01

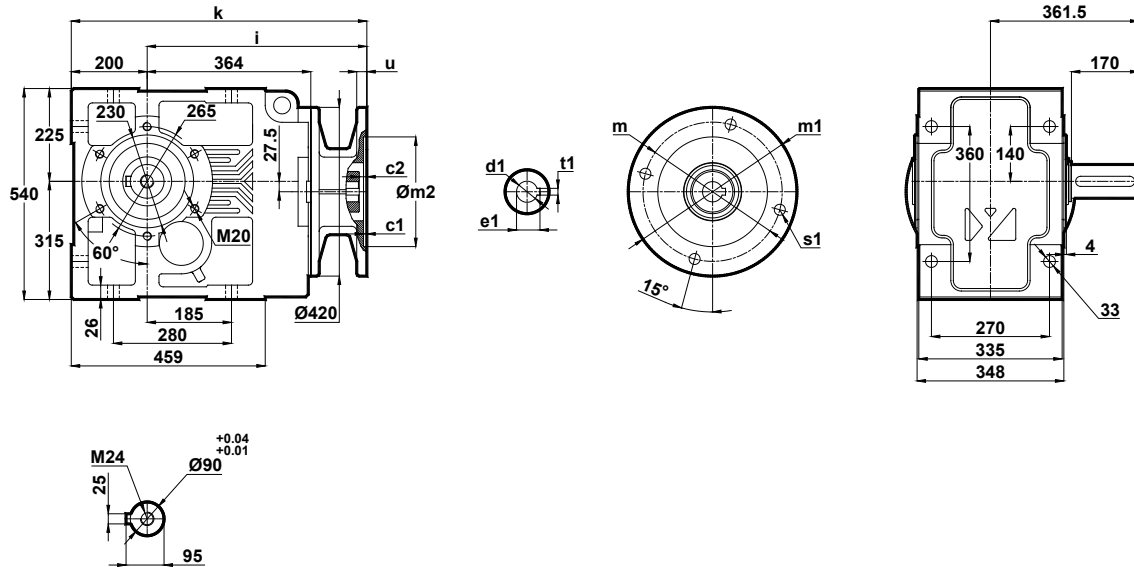

	c1	c2	s1	m	m1	m2	i	u	k	d1	t1	e1
132/B5	4.5	15	15	265	300	230	448	15	648	38	10	41.3
160/B5	5.5	10	19	300	350	250	517	20	717	42	12	45.3
180/B5	5.5	10	19	300	350	250	517	20	717	48	14	51.8
200/B5	5.5	10	19	350	400	300	539	20	739	55	16	59.3
225/B5	5.5	10	19	400	450	350	592	24	792	60	18	64.4
250/B5	5.5	10	19	500	550	450	592	24	792	65	18	69.4

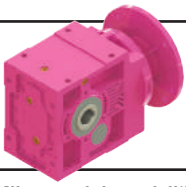

# Ölçü Sayfaları Dimension Pages Abmessungenseiten

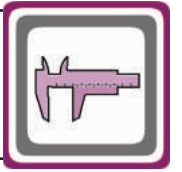

-Mil ucu çekirme deliği DIN 332 sayfa 2 / Tapped center hole to DIN 332, sheet 2 / Zentrierung mit gewinde DIN 332, Blatt 2

## KN773.02

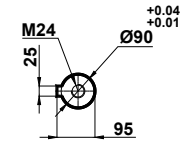
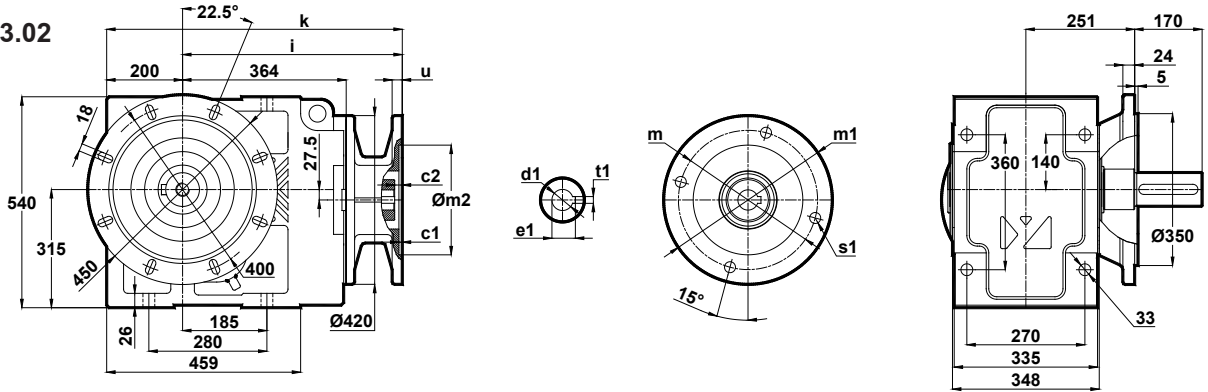

	c1	c2	s1	m	m1	m2	i	u	k	d1	t1	e1
132/B5	4.5	15	15	265	300	230	448	15	648	38	10	41.3
160/B5	5.5	10	19	300	350	250	517	20	717	42	12	45.3
180/B5	5.5	10	19	300	350	250	517	20	717	48	14	51.8
200/B5	5.5	10	19	350	400	300	539	20	739	55	16	59.3
225/B5	5.5	10	19	400	450	350	592	24	792	60	18	64.4
250/B5	5.5	10	19	500	550	450	592	24	792	65	18	69.4

## KN773.03

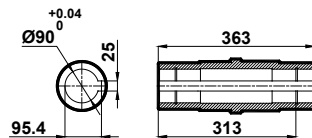
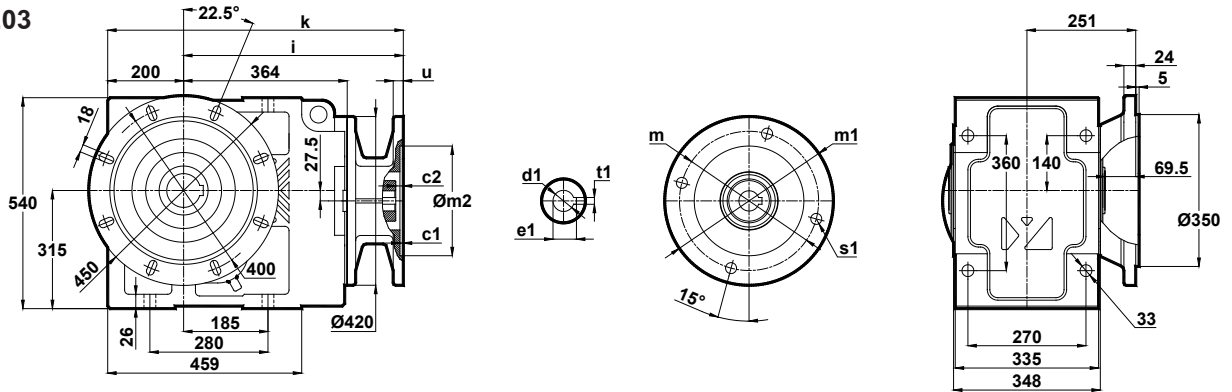

	c1	c2	s1	m	m1	m2	i	u	k	d1	t1	e1
132/B5	4.5	15	15	265	300	230	448	15	648	38	10	41.3
160/B5	5.5	10	19	300	350	250	517	20	717	42	12	45.3
180/B5	5.5	10	19	300	350	250	517	20	717	48	14	51.8
200/B5	5.5	10	19	350	400	300	539	20	739	55	16	59.3
225/B5	5.5	10	19	400	450	350	592	24	792	60	18	64.4
250/B5	5.5	10	19	500	550	450	592	24	792	65	18	69.4

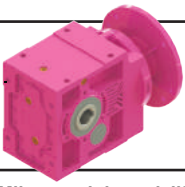

# Ölçü Sayfaları

## Dimension Pages

### Abmessungsseiten

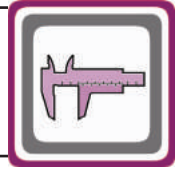

-Mil ucu çekirme deliği DIN 332 sayfa 2 / Tapped center hole to DIN 332, sheet 2 / Zentrierung mit gewinde DIN 332, Blatt 2

#### KN773.04

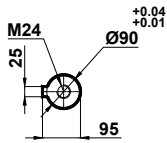
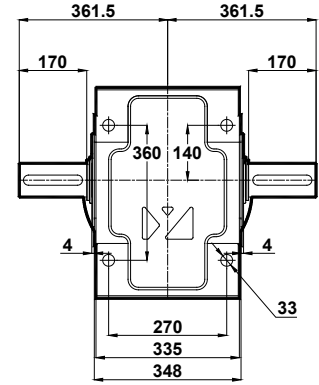
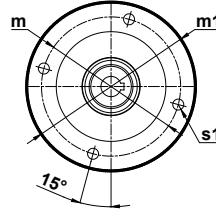
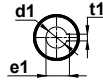
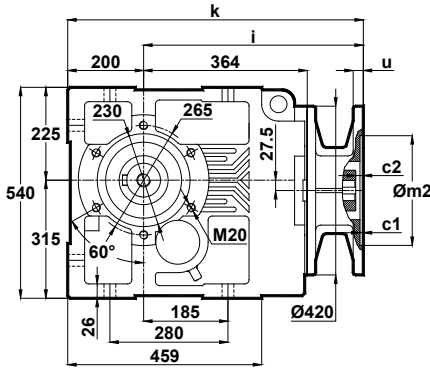

	c1	c2	s1	m	m1	m2	i	u	k	d1	t1	e1
132/B5	4.5	15	15	265	300	230	448	15	648	38	10	41.3
160/B5	5.5	10	19	300	350	250	517	20	717	42	12	45.3
180/B5	5.5	10	19	300	350	250	517	20	717	48	14	51.8
200/B5	5.5	10	19	350	400	300	539	20	739	55	16	59.3
225/B5	5.5	10	19	400	450	350	592	24	792	60	18	64.4
250/B5	5.5	10	19	500	550	450	592	24	792	65	18	69.4

#### KN773.05

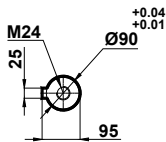
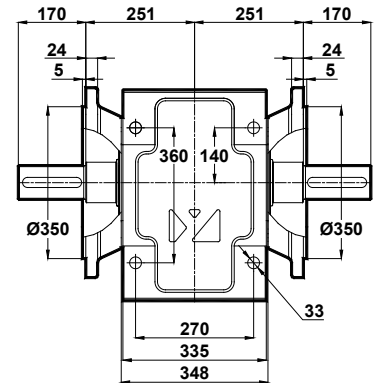
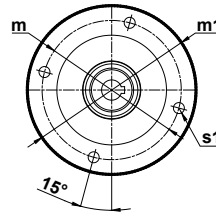
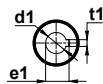
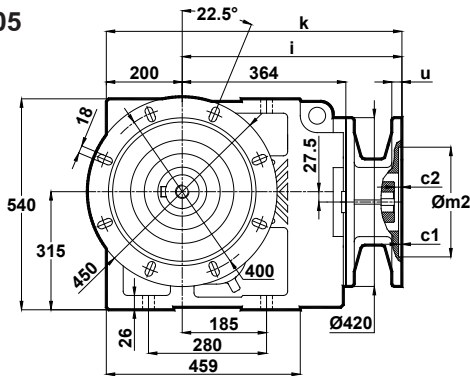

	c1	c2	s1	m	m1	m2	i	u	k	d1	t1	e1
132/B5	4.5	15	15	265	300	230	448	15	648	38	10	41.3
160/B5	5.5	10	19	300	350	250	517	20	717	42	12	45.3
180/B5	5.5	10	19	300	350	250	517	20	717	48	14	51.8
200/B5	5.5	10	19	350	400	300	539	20	739	55	16	59.3
225/B5	5.5	10	19	400	450	350	592	24	792	60	18	64.4
250/B5	5.5	10	19	500	550	450	592	24	792	65	18	69.4

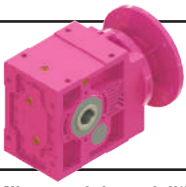

# Ölçü Sayfaları

## Dimension Pages

### Abmessungsseiten

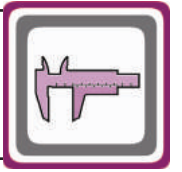

-Mil ucu çekirme deliği DIN 332 sayfa 2 / Tapped center hole to DIN 332, sheet 2 / Zentrierung mit gewinde DIN 332, Blatt 2

KN773.08

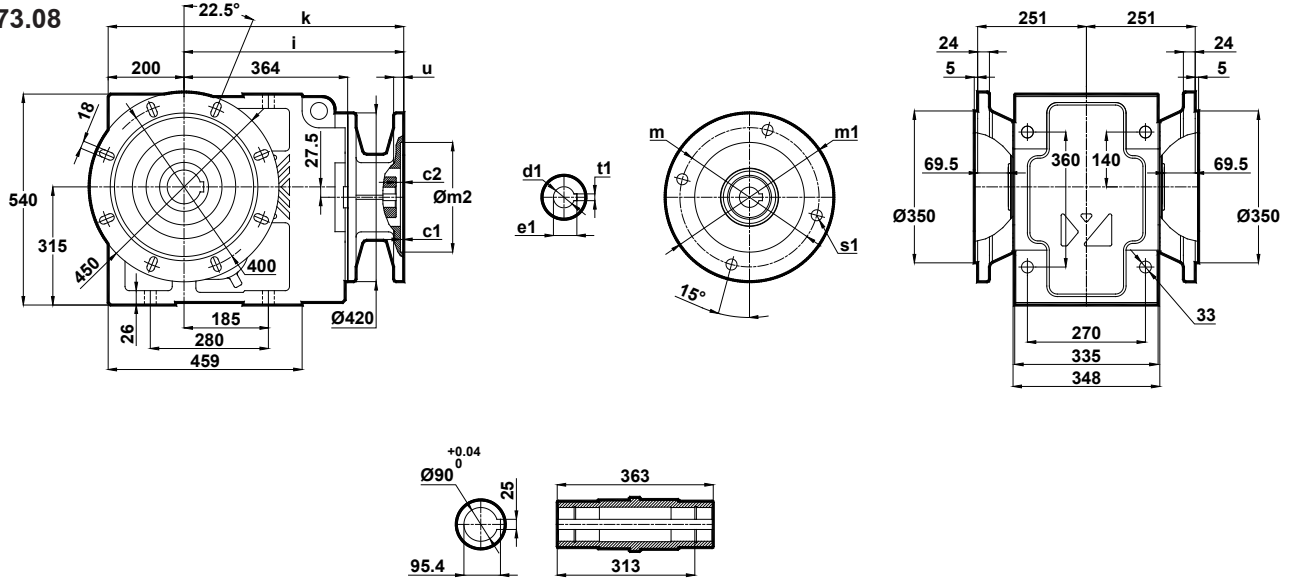

	c1	c2	s1	m	m1	m2	i	u	k	d1	t1	e1
132/B5	4.5	15	15	265	300	230	448	15	648	38	10	41.3
160/B5	5.5	10	19	300	350	250	517	20	717	42	12	45.3
180/B5	5.5	10	19	300	350	250	517	20	717	48	14	51.8
200/B5	5.5	10	19	350	400	300	539	20	739	55	16	59.3
225/B5	5.5	10	19	400	450	350	592	24	792	60	18	64.4
250/B5	5.5	10	19	500	550	450	592	24	792	65	18	69.4

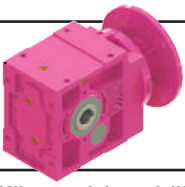

# Ölçü Sayfaları

## Dimension Pages

### Abmessungsseiten

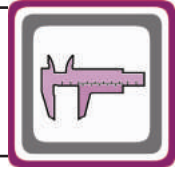

-Mil ucu çekirme deliği DIN 332 sayfa 2 / Tapped center hole to DIN 332, sheet 2 / Zentrierung mit gewinde DIN 332, Blatt 2

#### KN774.00

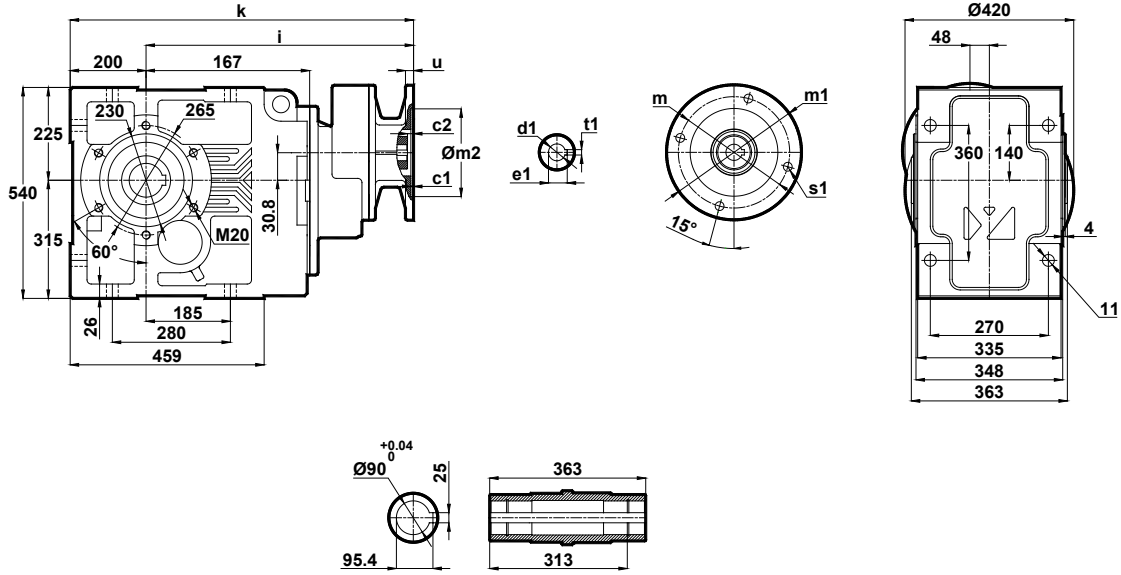

	c1	c2	s1	m	m1	m2	i	u	k	d1	t1	e1
90/B5	4	5	13	165	200	130	523	12	723	24	8	27.3
100/B5	4.5	9	15	215	250	180	541	15	741	28	8	31.3
112/B5	4.5	9	15	215	250	180	560	15	741	28	8	31.3
132/B5	4.5	6	15	265	300	230	639	15	760	38	10	41.3

#### KN774.01

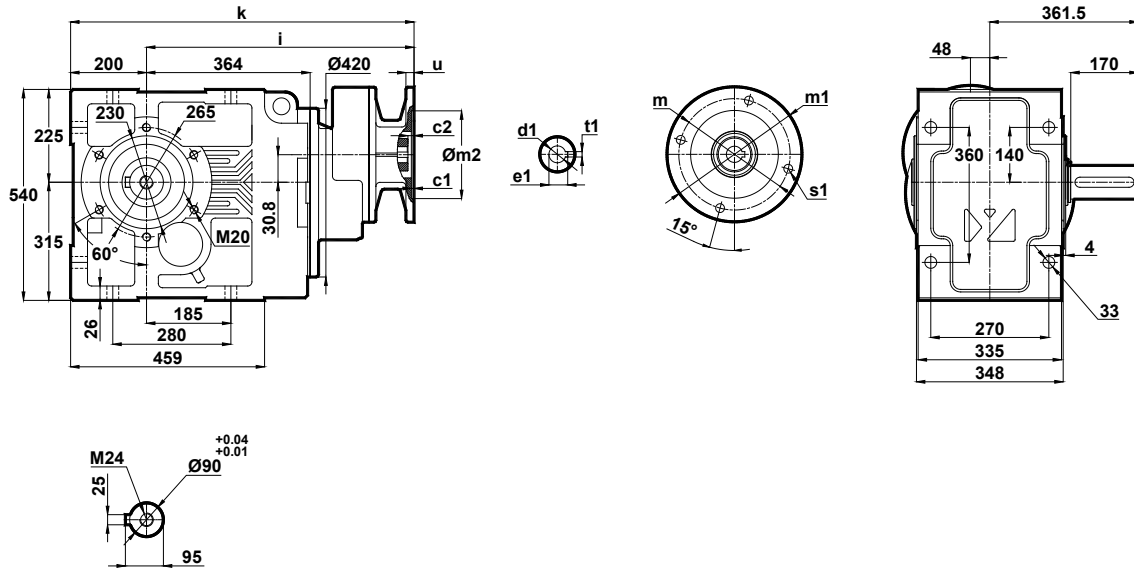

	c1	c2	s1	m	m1	m2	i	u	k	d1	t1	e1
90/B5	4	5	13	165	200	130	523	12	723	24	8	27.3
100/B5	4.5	9	15	215	250	180	541	15	741	28	8	31.3
112/B5	4.5	9	15	215	250	180	560	15	741	28	8	31.3
132/B5	4.5	6	15	265	300	230	639	15	760	38	10	41.3

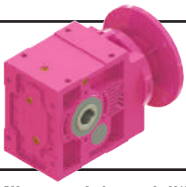

# Ölçü Sayfaları

## Dimension Pages

### Abmessungsseiten

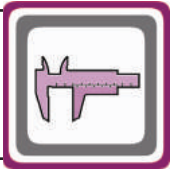

-Mil ucu çektirme deliği DIN 332 sayfa 2 / Tapped center hole to DIN 332, sheet 2 / Zentrierung mit gewinde DIN 332, Blatt 2

#### KN774.02

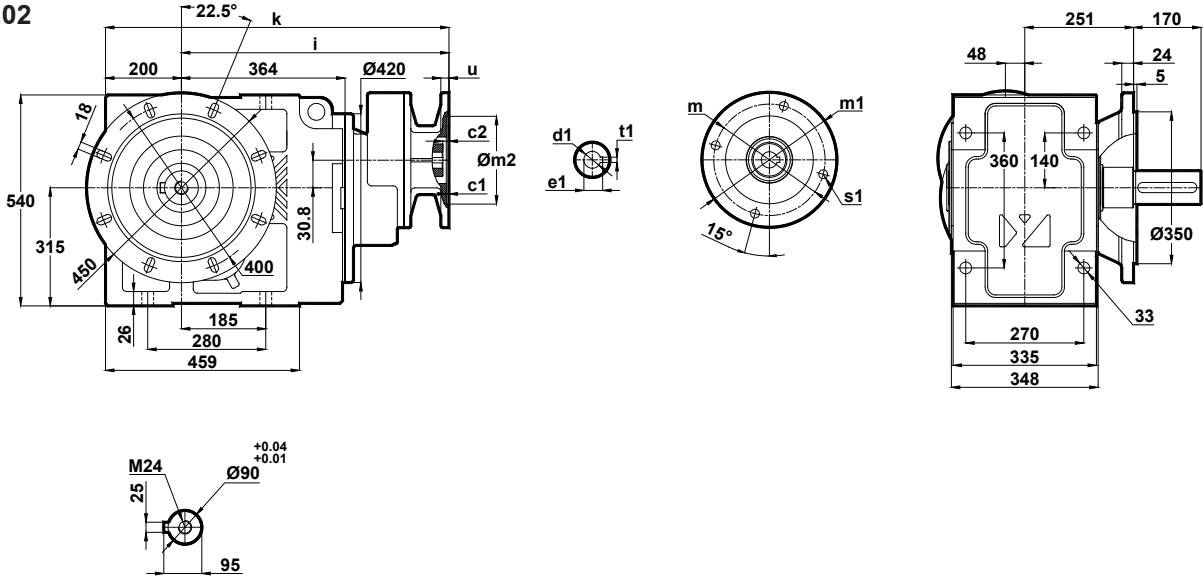

	c1	c2	s1	m	m1	m2	i	u	k	d1	t1	e1
90/B5	4	5	13	165	200	130	523	12	723	24	8	27.3
100/B5	4.5	9	15	215	250	180	541	15	741	28	8	31.3
112/B5	4.5	9	15	215	250	180	560	15	741	28	8	31.3
132/B5	4.5	6	15	265	300	230	639	15	760	38	10	41.3

#### KN774.03

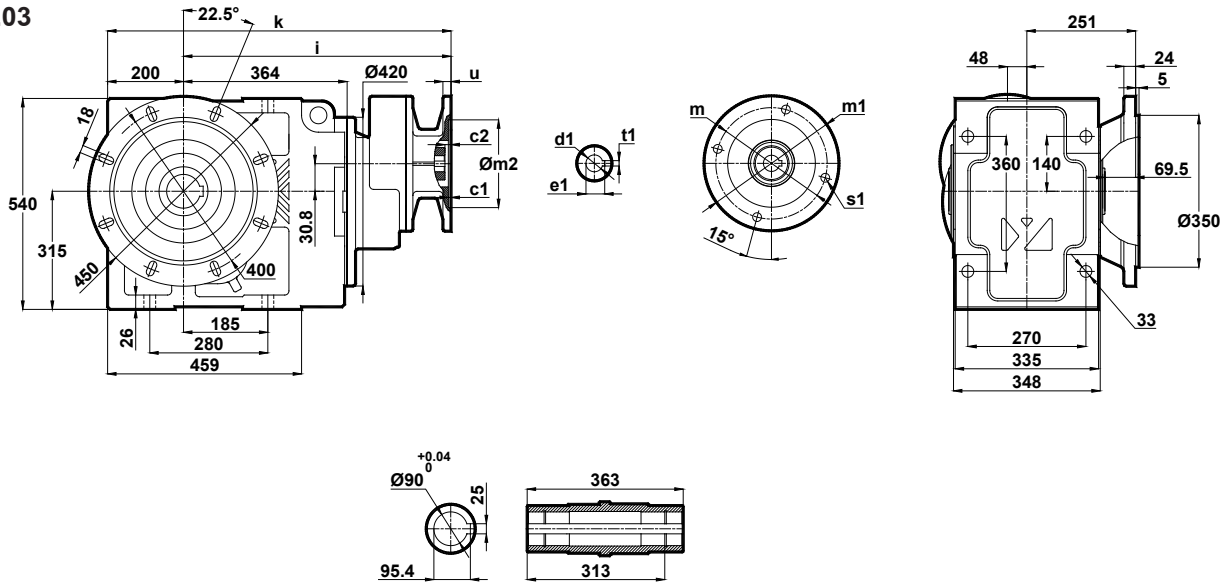

	c1	c2	s1	m	m1	m2	i	u	k	d1	t1	e1
90/B5	4	5	13	165	200	130	523	12	723	24	8	27.3
100/B5	4.5	9	15	215	250	180	541	15	741	28	8	31.3
112/B5	4.5	9	15	215	250	180	560	15	741	28	8	31.3
132/B5	4.5	6	15	265	300	230	639	15	760	38	10	41.3

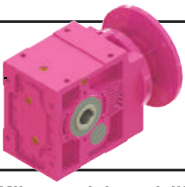

# Ölçü Sayfaları

## Dimension Pages

### Abmessungsseiten

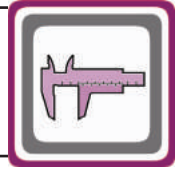

-Mil ucu çekirme deliği DIN 332 sayfa 2 / Tapped center hole to DIN 332, sheet 2 / Zentrierung mit gewinde DIN 332, Blatt 2

#### KN774.04

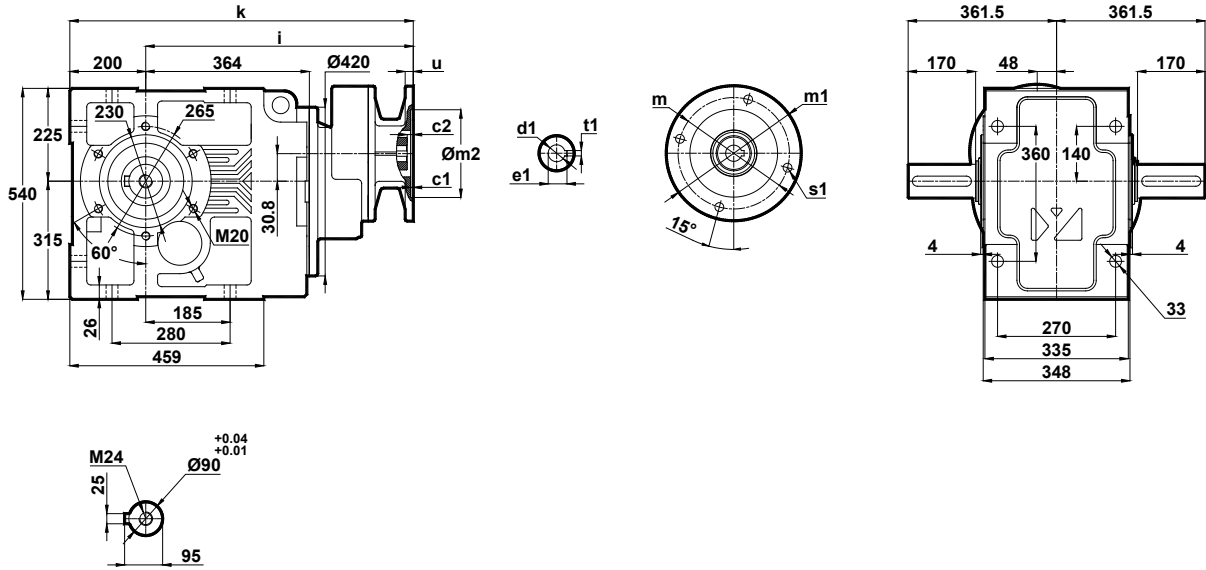

	c1	c2	s1	m	m1	m2	i	u	k	d1	t1	e1
90/B5	4	5	13	165	200	130	523	12	723	24	8	27.3
100/B5	4.5	9	15	215	250	180	541	15	741	28	8	31.3
112/B5	4.5	9	15	215	250	180	560	15	741	28	8	31.3
132/B5	4.5	6	15	265	300	230	639	15	760	38	10	41.3

#### KN774.05

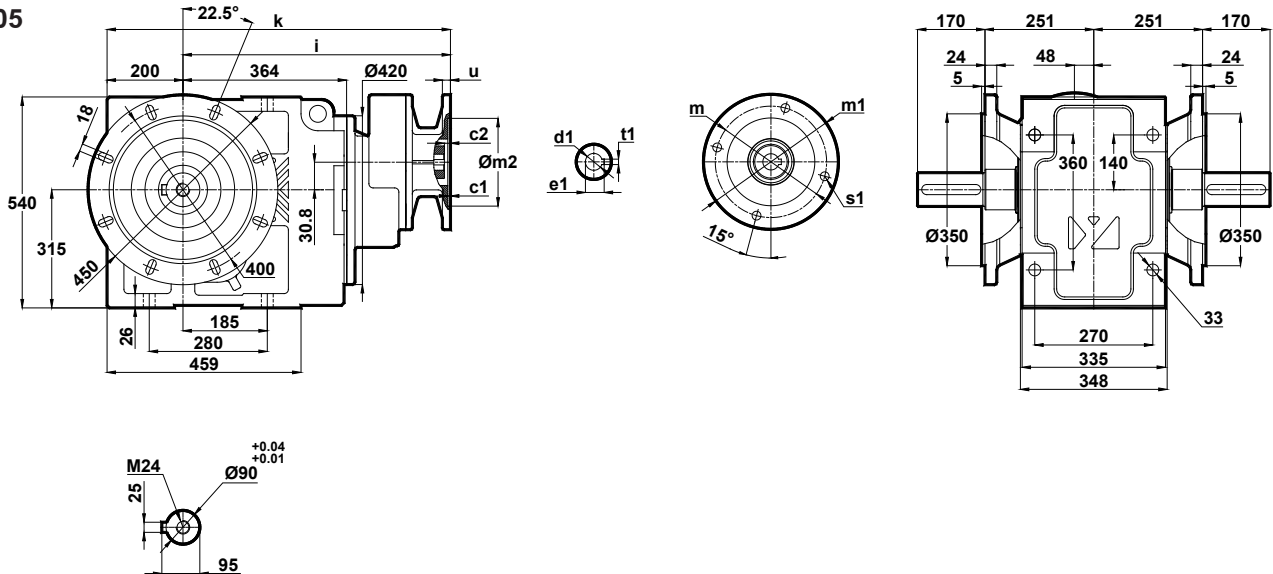

	c1	c2	s1	m	m1	m2	i	u	k	d1	t1	e1
90/B5	4	5	13	165	200	130	523	12	723	24	8	27.3
100/B5	4.5	9	15	215	250	180	541	15	741	28	8	31.3
112/B5	4.5	9	15	215	250	180	560	15	741	28	8	31.3
132/B5	4.5	6	15	265	300	230	639	15	760	38	10	41.3

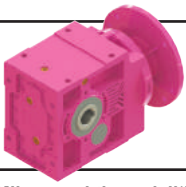

# Ölçü Sayfaları Dimension Pages Abmessungenseiten

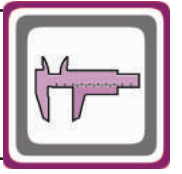

-Mil ucu çektirme deliği DIN 332 sayfa 2 / Tapped center hole to DIN 332, sheet 2 / Zentrierung mit gewinde DIN 332, Blatt 2

KN774.08

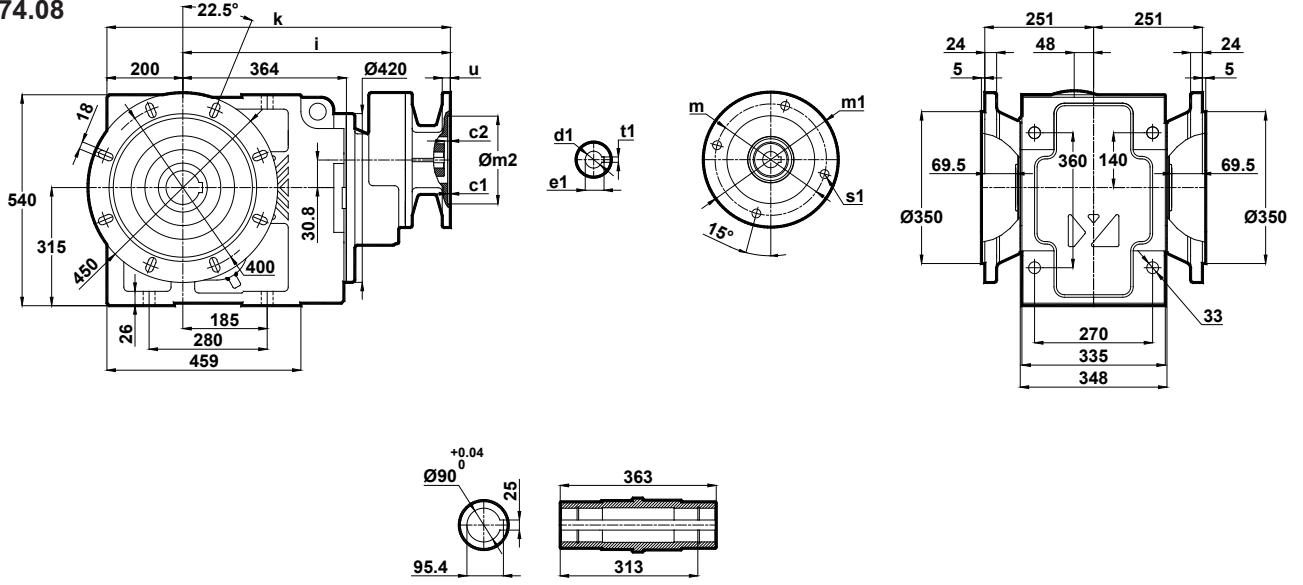

	c1	c2	s1	m	m1	m2	i	u	k	d1	t1	e1
90/B5	4	5	13	165	200	130	523	12	723	24	8	27.3
100/B5	4.5	9	15	215	250	180	541	15	741	28	8	31.3
112/B5	4.5	9	15	215	250	180	560	15	741	28	8	31.3
132/B5	4.5	6	15	265	300	230	639	15	760	38	10	41.3

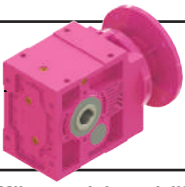

# Ölçü Sayfaları Dimension Pages Abmessungsseiten

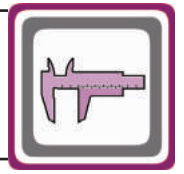

-Mil ucu çekirme deliği DIN 332 sayfa 2 / Tapped center hole to DIN 332, sheet 2 / Zentrierung mit gewinde DIN 332, Blatt 2

KN775.00  
KN776.00

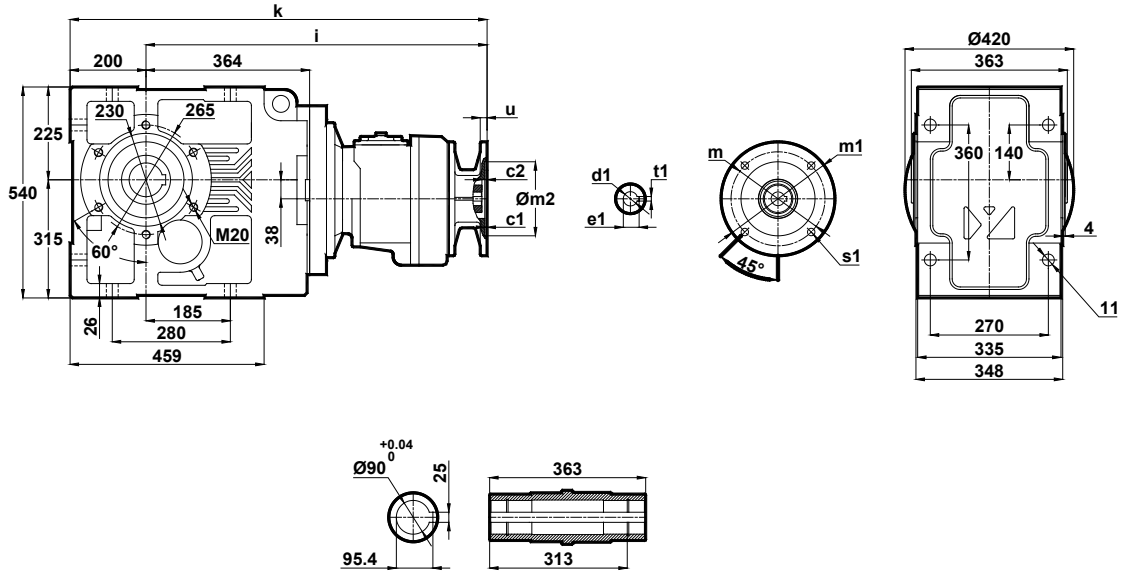

	c1	c2	s1	m	m1	m2	i	u	k	d1	t1	e1
71/B5	4	9	11	130	160	110	674	12	874	14	5	16.3
80/B5	4	9	13	165	200	130	674	12	874	19	6	21.8
90/B5	4	9	13	165	200	130	674	12	874	24	8	27.3
100/B5	4.5	9	15	215	250	180	691	15	891	28	8	31.3

KN775.01  
KN776.01

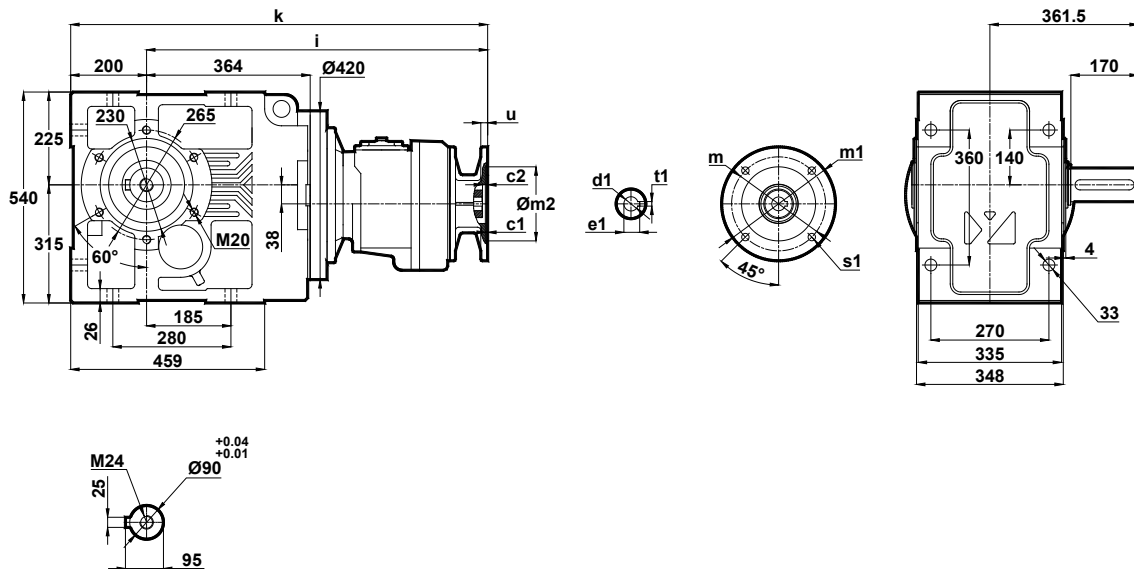

	c1	c2	s1	m	m1	m2	i	u	k	d1	t1	e1
71/B5	4	9	11	130	160	110	674	12	874	14	5	16.3
80/B5	4	9	13	165	200	130	674	12	874	19	6	21.8
90/B5	4	9	13	165	200	130	674	12	874	24	8	27.3
100/B5	4.5	9	15	215	250	180	691	15	891	28	8	31.3

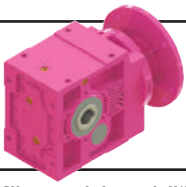

# Ölçü Sayfaları Dimension Pages Abmessungenseiten

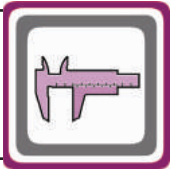

-Mil ucu çekirme deliği DIN 332 sayfa 2 / Tapped center hole to DIN 332, sheet 2 / Zentrierung mit gewinde DIN 332, Blatt 2

KN775.02  
KN776.02

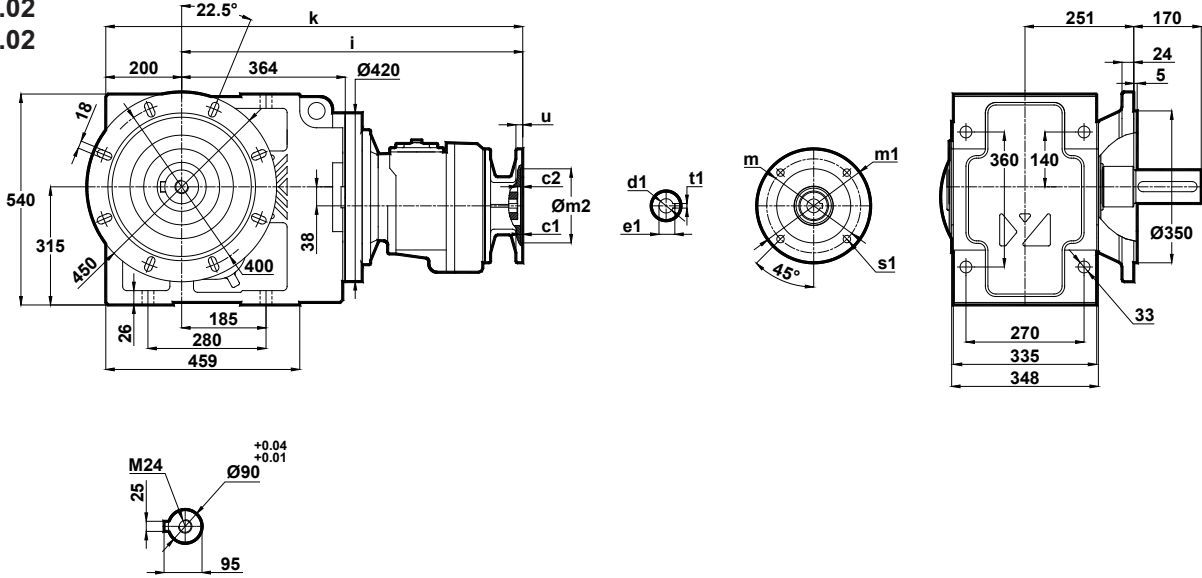

	c1	c2	s1	m	m1	m2	i	u	k	d1	t1	e1
71/B5	4	9	11	130	160	110	674	12	874	14	5	16.3
80/B5	4	9	13	165	200	130	674	12	874	19	6	21.8
90/B5	4	9	13	165	200	130	674	12	874	24	8	27.3
100/B5	4.5	9	15	215	250	180	691	15	891	28	8	31.3

KN775.03  
KN776.03

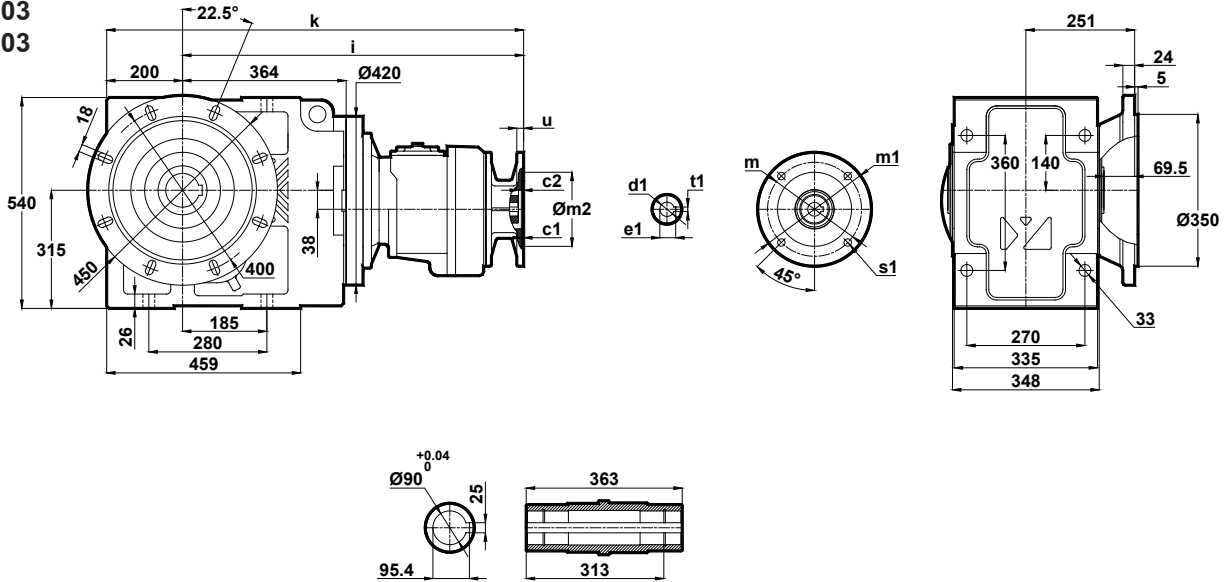

	c1	c2	s1	m	m1	m2	i	u	k	d1	t1	e1
71/B5	4	9	11	130	160	110	674	12	874	14	5	16.3
80/B5	4	9	13	165	200	130	674	12	874	19	6	21.8
90/B5	4	9	13	165	200	130	674	12	874	24	8	27.3
100/B5	4.5	9	15	215	250	180	691	15	891	28	8	31.3

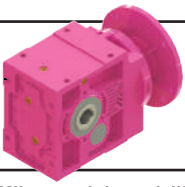

# Ölçü Sayfaları Dimension Pages Abmessungsseiten

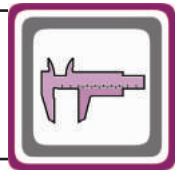

-Mil ucu çekirme deliği DIN 332 sayfa 2 / Tapped center hole to DIN 332, sheet 2 / Zentrierung mit gewinde DIN 332, Blatt 2

KN775.04  
KN776.04

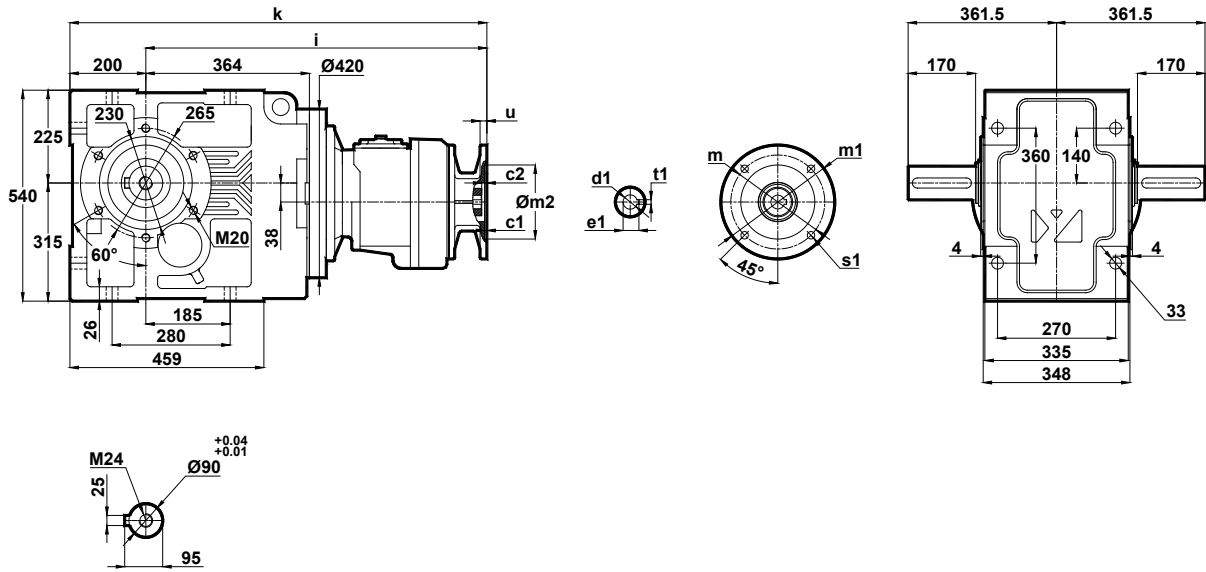

	c1	c2	s1	m	m1	m2	i	u	k	d1	t1	e1
71/B5	4	9	11	130	160	110	674	12	874	14	5	16.3
80/B5	4	9	13	165	200	130	674	12	874	19	6	21.8
90/B5	4	9	13	165	200	130	674	12	874	24	8	27.3
100/B5	4.5	9	15	215	250	180	691	15	891	28	8	31.3

KN775.05  
KN776.05

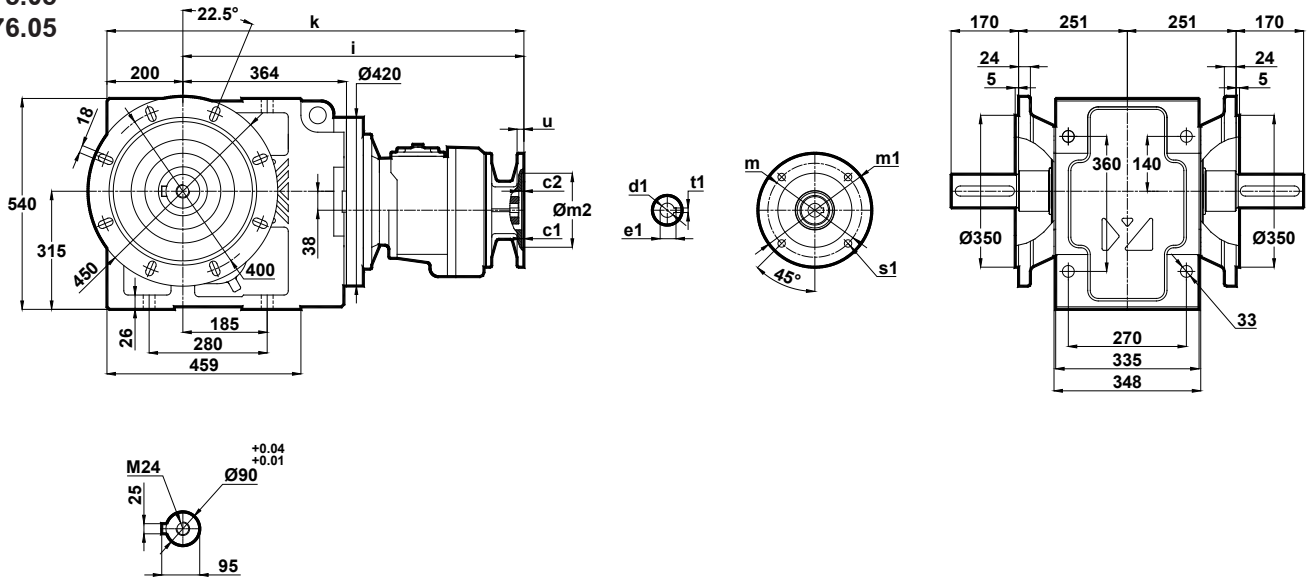

	c1	c2	s1	m	m1	m2	i	u	k	d1	t1	e1
71/B5	4	9	11	130	160	110	674	12	874	14	5	16.3
80/B5	4	9	13	165	200	130	674	12	874	19	6	21.8
90/B5	4	9	13	165	200	130	674	12	874	24	8	27.3
100/B5	4.5	9	15	215	250	180	691	15	891	28	8	31.3

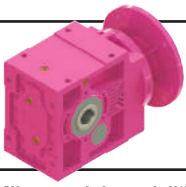

# Ölçü Sayfaları Dimension Pages Abmessungenseiten

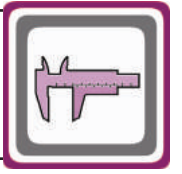

-Mil ucu çekirme deliği DIN 332 sayfa 2 / Tapped center hole to DIN 332, sheet 2 / Zentrierung mit gewinde DIN 332, Blatt 2

KN775.08  
KN776.08

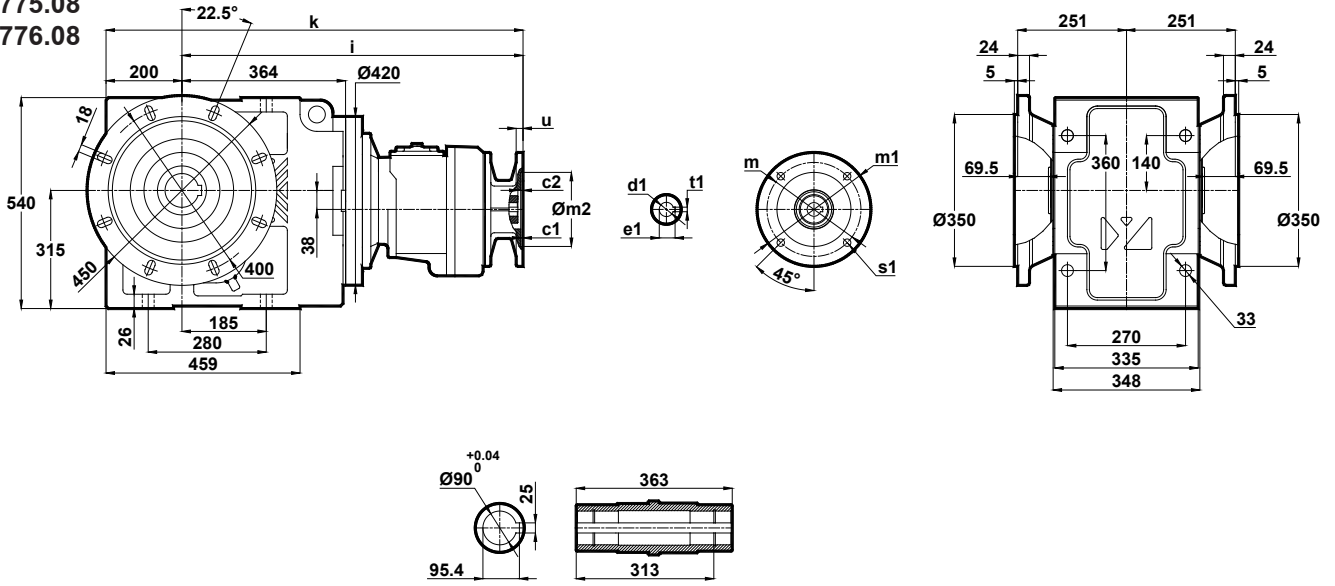

	c1	c2	s1	m	m1	m2	i	u	k	d1	t1	e1
71/B5	4	9	11	130	160	110	674	12	874	14	5	16.3
80/B5	4	9	13	165	200	130	674	12	874	19	6	21.8
90/B5	4	9	13	165	200	130	674	12	874	24	8	27.3
100/B5	4.5	9	15	215	250	180	691	15	891	28	8	31.3

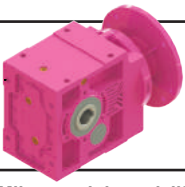

# Ölçü Sayfaları

## Dimension Pages

### Abmessungsseiten

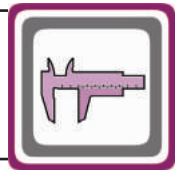

-Mil ucu çekirme deliği DIN 332 sayfa 2 / Tapped center hole to DIN 332, sheet 2 / Zentrierung mit gewinde DIN 332, Blatt 2

#### KN873.00

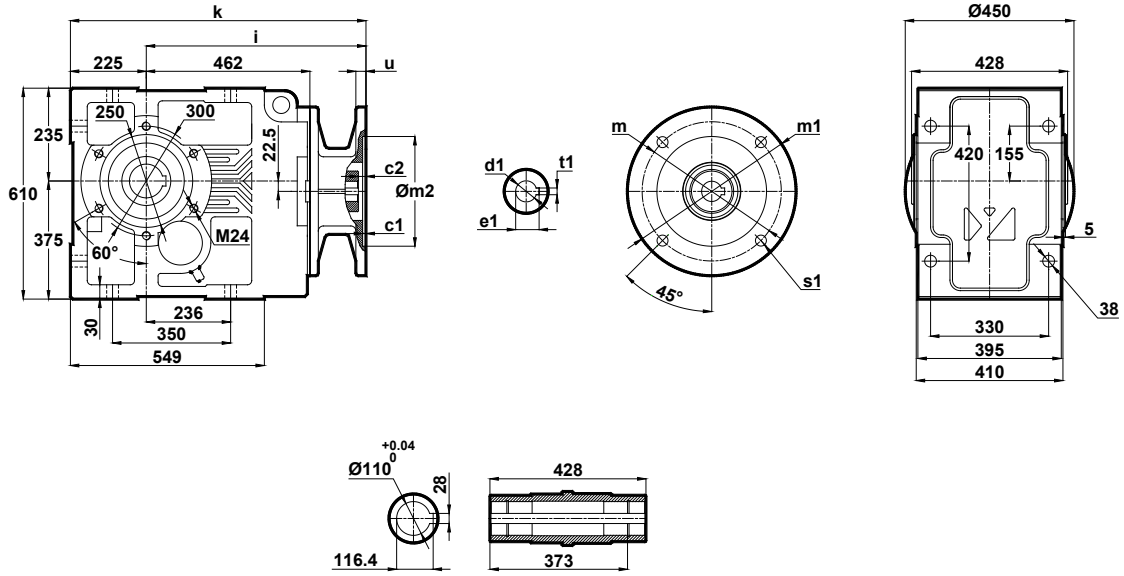

	c1	c2	s1	m	m1	m2	i	u	k	d1	t1	e1
132/B5	4.5	14	15	265	300	230	535	15	760	38	10	41.3
160/B5	5.5	10	19	300	350	250	680	20	905	42	12	45.3
180/B5	5.5	10	19	300	350	250	680	20	905	48	14	51.8
200/B4	5.5	10	19	350	400	300	680	22	905	55	16	59.3
225/B5	5.5	10	19	400	450	350	680	24	905	60	18	64.4
250/B5	5.5	10	19	500	550	450	680	24	905	65	18	69.4
280/B5	5.5	10	19	500	550	450	680	24	905	75	20	79.9

#### KN873.01

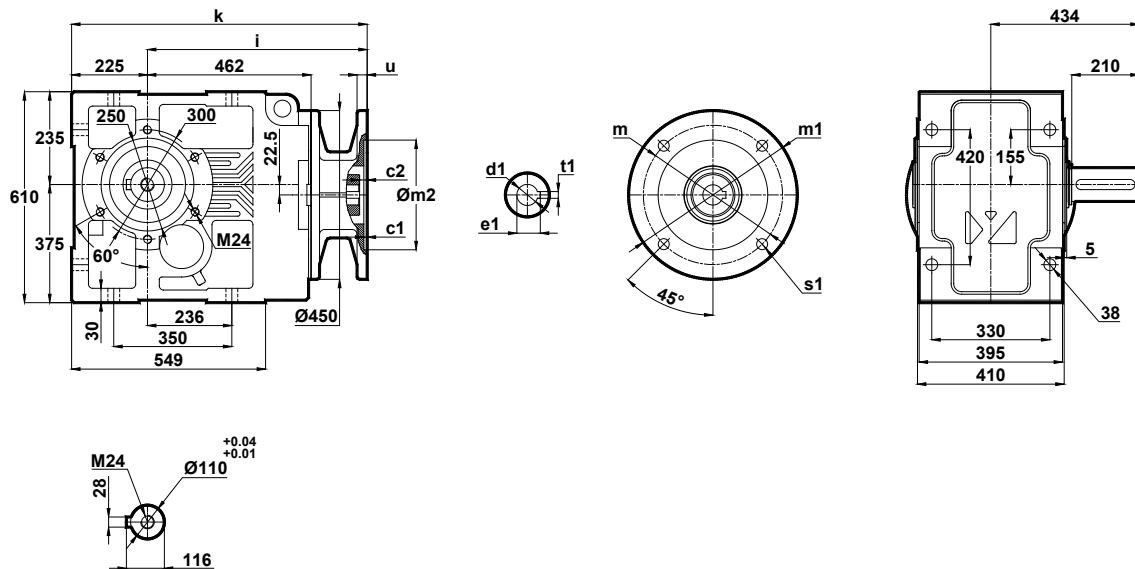

	c1	c2	s1	m	m1	m2	i	u	k	d1	t1	e1
132/B5	4.5	14	15	265	300	230	535	15	760	38	10	41.3
160/B5	5.5	10	19	300	350	250	680	20	905	42	12	45.3
180/B5	5.5	10	19	300	350	250	680	20	905	48	14	51.8
200/B4	5.5	10	19	350	400	300	680	22	905	55	16	59.3
225/B5	5.5	10	19	400	450	350	680	24	905	60	18	64.4
250/B5	5.5	10	19	500	550	450	680	24	905	65	18	69.4
280/B5	5.5	10	19	500	550	450	680	24	905	75	20	79.9

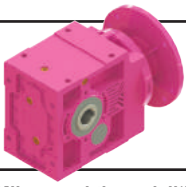

# Ölçü Sayfaları

## Dimension Pages

### Abmessungsseiten

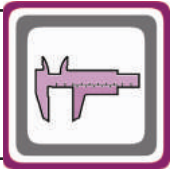

-Mil ucu çektirme deliği DIN 332 sayfa 2 / Tapped center hole to DIN 332, sheet 2 / Zentrierung mit gewinde DIN 332, Blatt 2

#### KN873.02

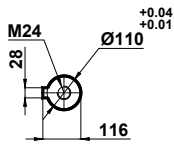
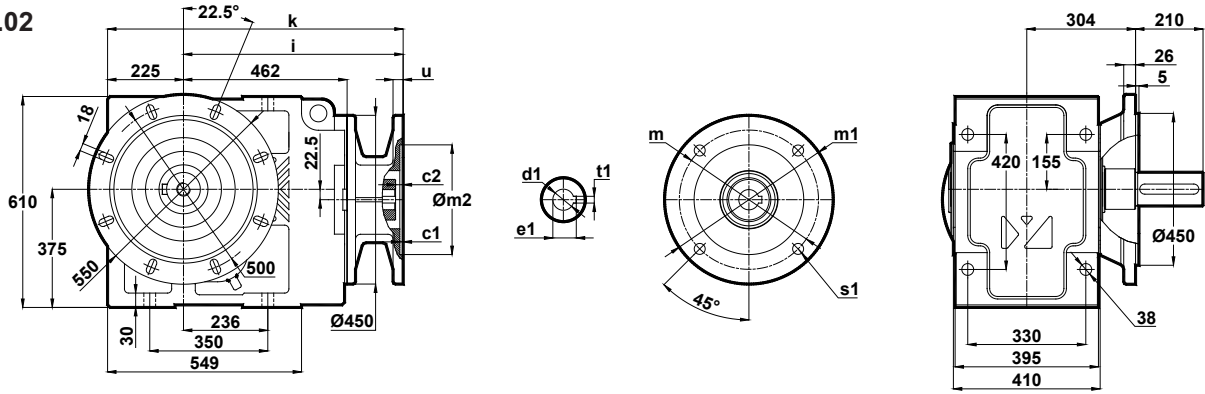

	c1	c2	s1	m	m1	m2	i	u	k	d1	t1	e1
132/B5	4.5	14	15	265	300	230	535	15	760	38	10	41.3
160/B5	5.5	10	19	300	350	250	680	20	905	42	12	45.3
180/B5	5.5	10	19	300	350	250	680	20	905	48	14	51.8
200/B4	5.5	10	19	350	400	300	680	22	905	55	16	59.3
225/B5	5.5	10	19	400	450	350	680	24	905	60	18	64.4
250/B5	5.5	10	19	500	550	450	680	24	905	65	18	69.4
280/B5	5.5	10	19	500	550	450	680	24	905	75	20	79.9

#### KN873.03

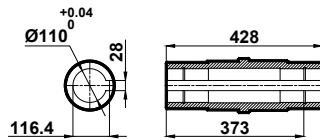
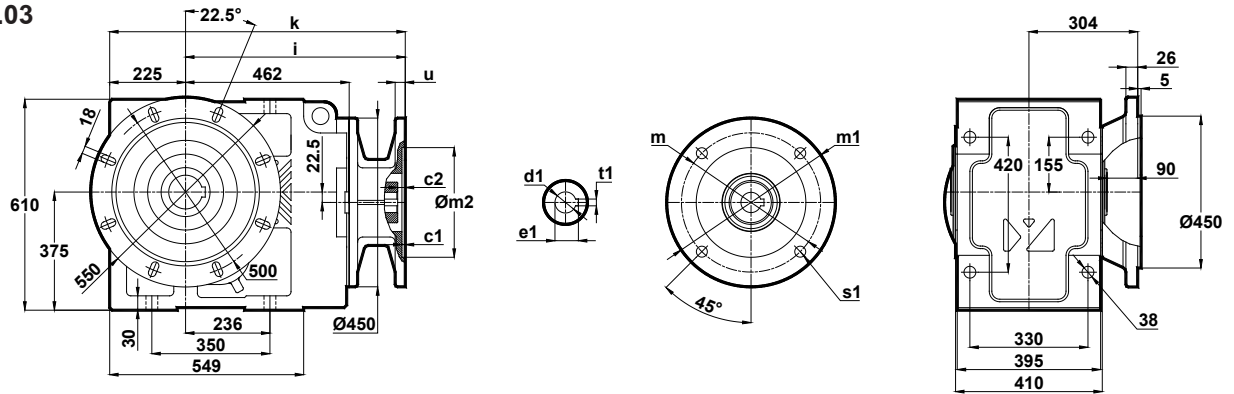

	c1	c2	s1	m	m1	m2	i	u	k	d1	t1	e1
132/B5	4.5	14	15	265	300	230	535	15	760	38	10	41.3
160/B5	5.5	10	19	300	350	250	680	20	905	42	12	45.3
180/B5	5.5	10	19	300	350	250	680	20	905	48	14	51.8
200/B4	5.5	10	19	350	400	300	680	22	905	55	16	59.3
225/B5	5.5	10	19	400	450	350	680	24	905	60	18	64.4
250/B5	5.5	10	19	500	550	450	680	24	905	65	18	69.4
280/B5	5.5	10	19	500	550	450	680	24	905	75	20	79.9

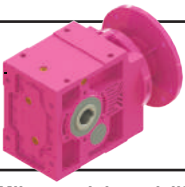

# Ölçü Sayfaları Dimension Pages Abmessungsseiten

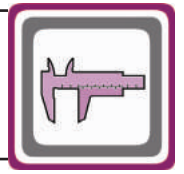

-Mil ucu çekirme deliği DIN 332 sayfa 2 / Tapped center hole to DIN 332, sheet 2 / Zentrierung mit gewinde DIN 332, Blatt 2

## KN873.04

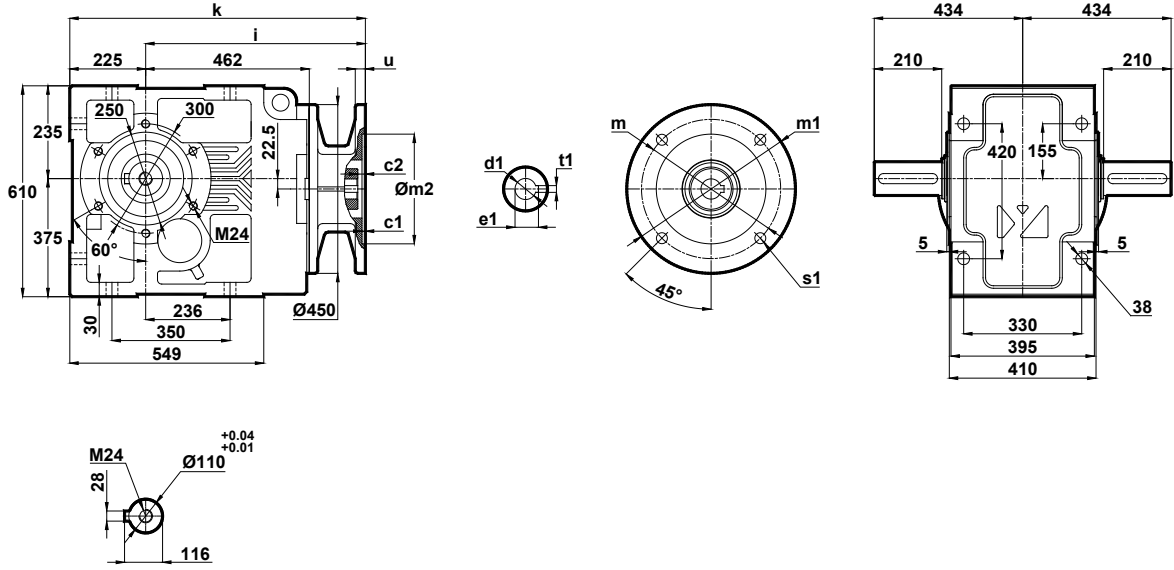

	c1	c2	s1	m	m1	m2	i	u	k	d1	t1	e1
132/B5	4.5	14	15	265	300	230	535	15	760	38	10	41.3
160/B5	5.5	10	19	300	350	250	680	20	905	42	12	45.3
180/B5	5.5	10	19	300	350	250	680	20	905	48	14	51.8
200/B4	5.5	10	19	350	400	300	680	22	905	55	16	59.3
225/B5	5.5	10	19	400	450	350	680	24	905	60	18	64.4
250/B5	5.5	10	19	500	550	450	680	24	905	65	18	69.4
280/B5	5.5	10	19	500	550	450	680	24	905	75	20	79.9

## KN873.05

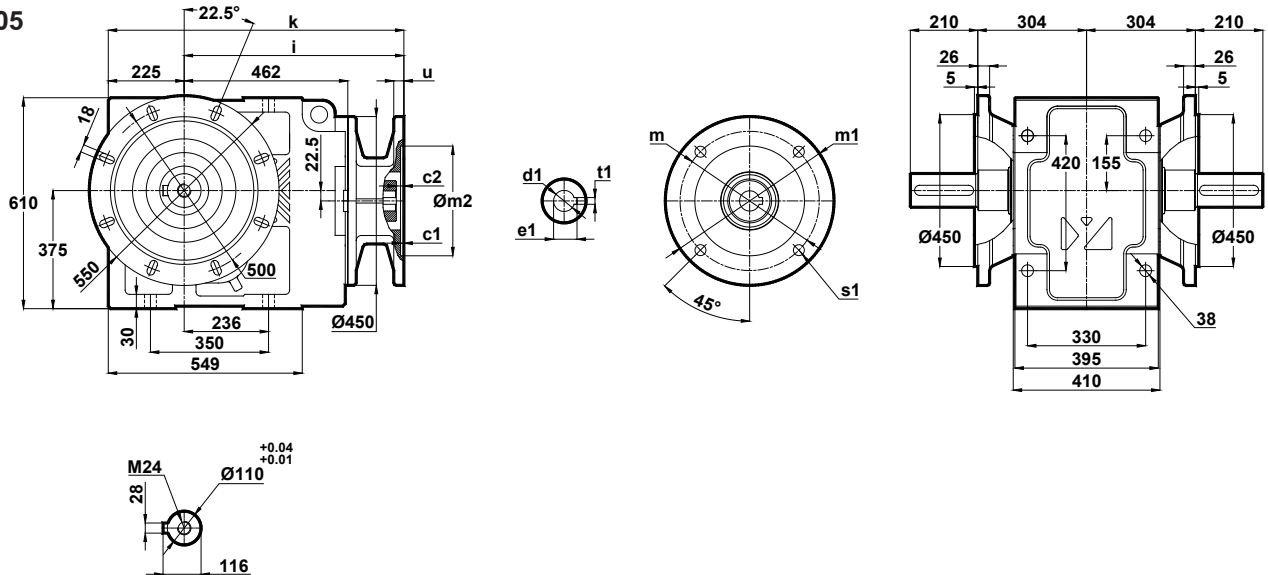

	c1	c2	s1	m	m1	m2	i	u	k	d1	t1	e1
132/B5	4.5	14	15	265	300	230	535	15	760	38	10	41.3
160/B5	5.5	10	19	300	350	250	680	20	905	42	12	45.3
180/B5	5.5	10	19	300	350	250	680	20	905	48	14	51.8
200/B4	5.5	10	19	350	400	300	680	22	905	55	16	59.3
225/B5	5.5	10	19	400	450	350	680	24	905	60	18	64.4
250/B5	5.5	10	19	500	550	450	680	24	905	65	18	69.4
280/B5	5.5	10	19	500	550	450	680	24	905	75	20	79.9

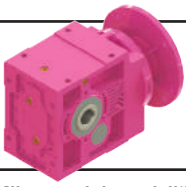

# Ölçü Sayfaları

## Dimension Pages

### Abmessungsseiten

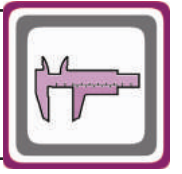

-Mil ucu çekirme deliği DIN 332 sayfa 2 / Tapped center hole to DIN 332, sheet 2 / Zentrierung mit gewinde DIN 332, Blatt 2

KN873.08

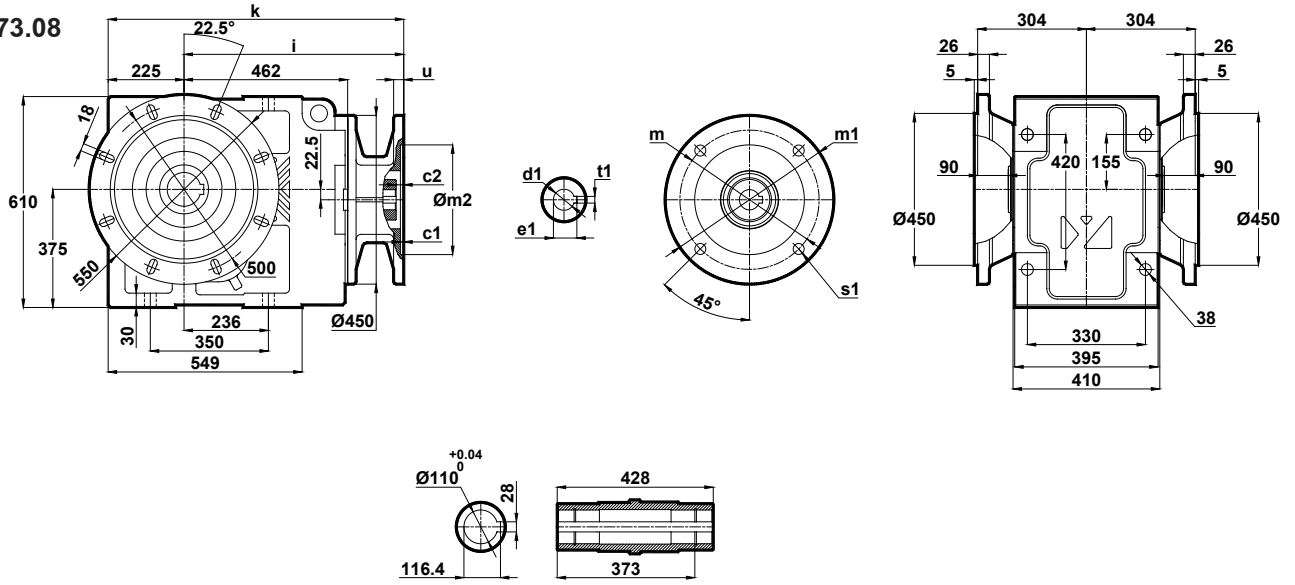

	c1	c2	s1	m	m1	m2	i	u	k	d1	t1	e1
132/B5	4.5	14	15	265	300	230	535	15	760	38	10	41.3
160/B5	5.5	10	19	300	350	250	680	20	905	42	12	45.3
180/B5	5.5	10	19	300	350	250	680	20	905	48	14	51.8
200/B4	5.5	10	19	350	400	300	680	22	905	55	16	59.3
225/B5	5.5	10	19	400	450	350	680	24	905	60	18	64.4
250/B5	5.5	10	19	500	550	450	680	24	905	65	18	69.4
280/B5	5.5	10	19	500	550	450	680	24	905	75	20	79.9

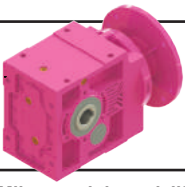

# Ölçü Sayfaları Dimension Pages Abmessungsseiten

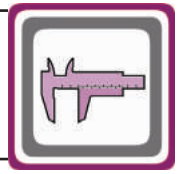

-Mil ucu çekirme deliği DIN 332 sayfa 2 / Tapped center hole to DIN 332, sheet 2 / Zentrierung mit gewinde DIN 332, Blatt 2

## KN874.00

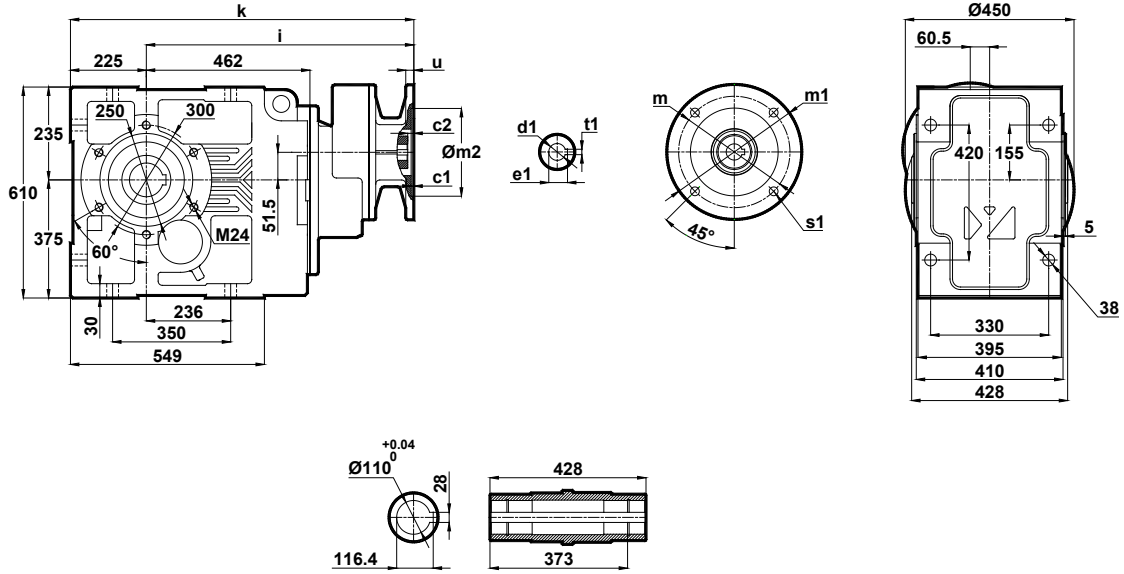

	c1	c2	s1	m	m1	m2	i	u	k	d1	t1	e1
100/B5	4.5	20	15	215	250	180	653	15	878	28	8	31.3
112/B5	4.5	20	15	215	250	180	653	15	878	28	8	31.3
132/B5	4.5	9	15	265	300	230	674	15	899	38	10	41.3
160/B5	5.5	10	19	300	350	250	749	18	974	42	12	45.3
180/B5	5.5	10	19	300	350	250	749	18	974	48	14	51.8

## KN874.01

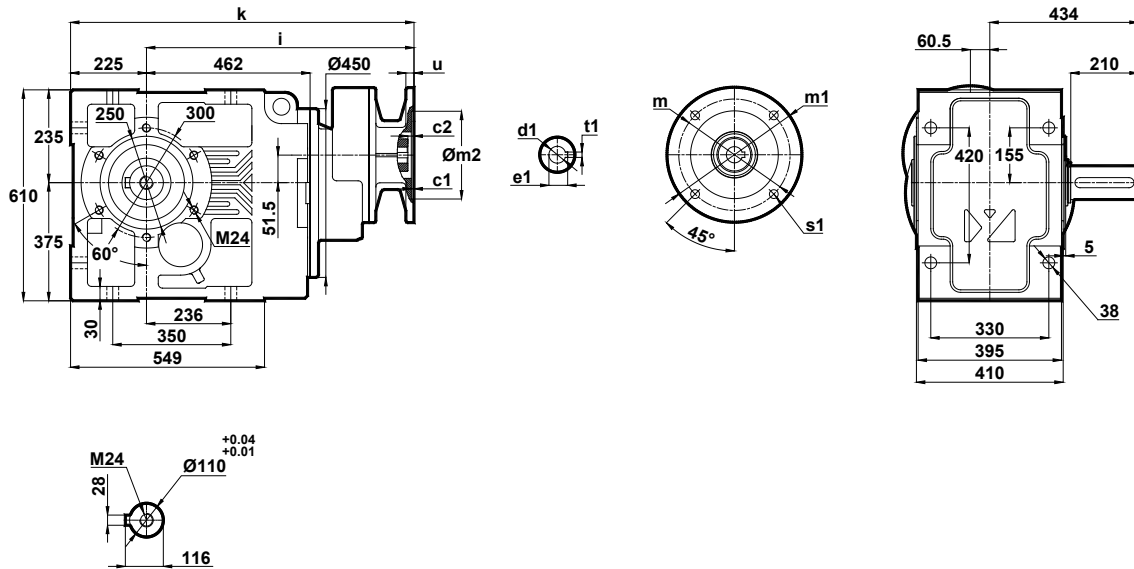

	c1	c2	s1	m	m1	m2	i	u	k	d1	t1	e1
100/B5	4.5	20	15	215	250	180	653	15	878	28	8	31.3
112/B5	4.5	20	15	215	250	180	653	15	878	28	8	31.3
132/B5	4.5	9	15	265	300	230	674	15	899	38	10	41.3
160/B5	5.5	10	19	300	350	250	749	18	974	42	12	45.3
180/B5	5.5	10	19	300	350	250	749	18	974	48	14	51.8

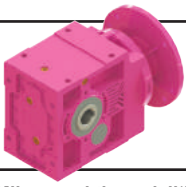

# Ölçü Sayfaları

## Dimension Pages

### Abmessungsseiten

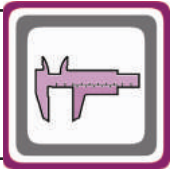

-Mil ucu çekirme deliği DIN 332 sayfa 2 / Tapped center hole to DIN 332, sheet 2 / Zentrierung mit gewinde DIN 332, Blatt 2

#### KN874.02

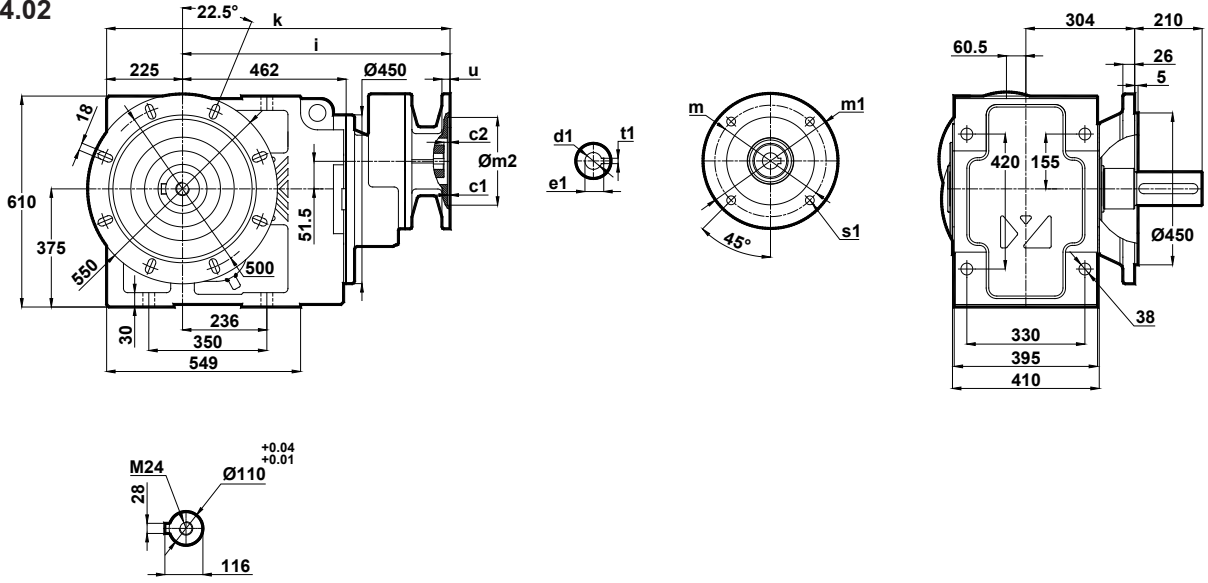

	c1	c2	s1	m	m1	m2	i	u	k	d1	t1	e1
100/B5	4.5	20	15	215	250	180	653	15	878	28	8	31.3
112/B5	4.5	20	15	215	250	180	653	15	878	28	8	31.3
132/B5	4.5	9	15	265	300	230	674	15	899	38	10	41.3
160/B5	5.5	10	19	300	350	250	749	18	974	42	12	45.3
180/B5	5.5	10	19	300	350	250	749	18	974	48	14	51.8

#### KN874.03

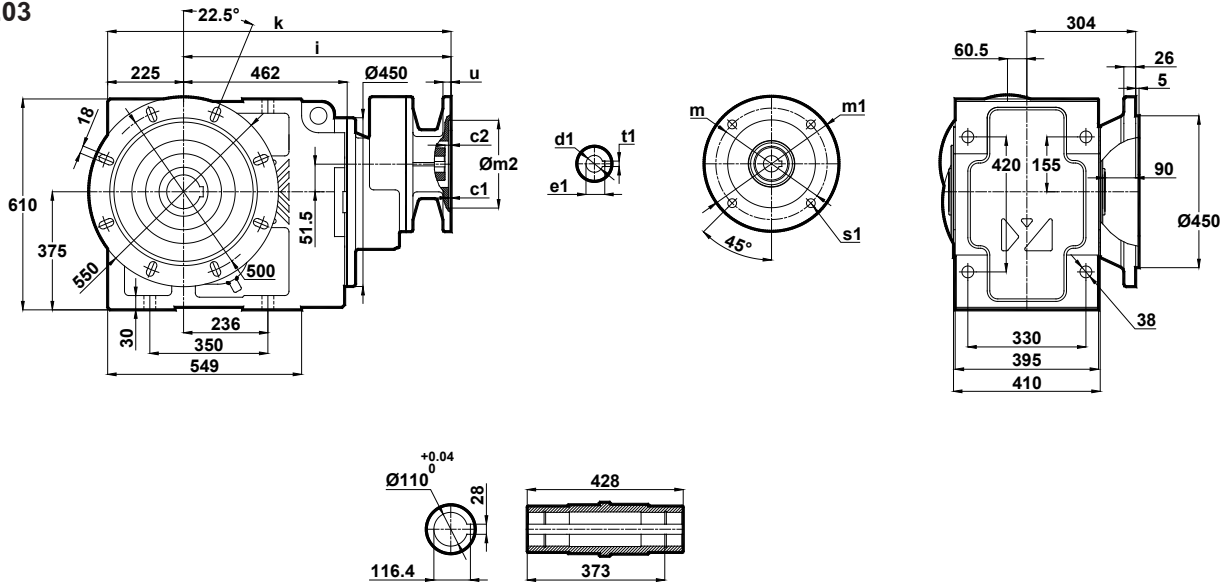

	c1	c2	s1	m	m1	m2	i	u	k	d1	t1	e1
100/B5	4.5	20	15	215	250	180	653	15	878	28	8	31.3
112/B5	4.5	20	15	215	250	180	653	15	878	28	8	31.3
132/B5	4.5	9	15	265	300	230	674	15	899	38	10	41.3
160/B5	5.5	10	19	300	350	250	749	18	974	42	12	45.3
180/B5	5.5	10	19	300	350	250	749	18	974	48	14	51.8

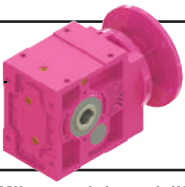

# Ölçü Sayfaları

## Dimension Pages

### Abmessungsseiten

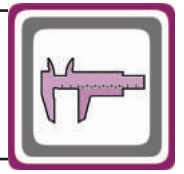

-Mil ucu çekirme deliği DIN 332 sayfa 2 / Tapped center hole to DIN 332, sheet 2 / Zentrierung mit gewinde DIN 332, Blatt 2

#### KN874.04

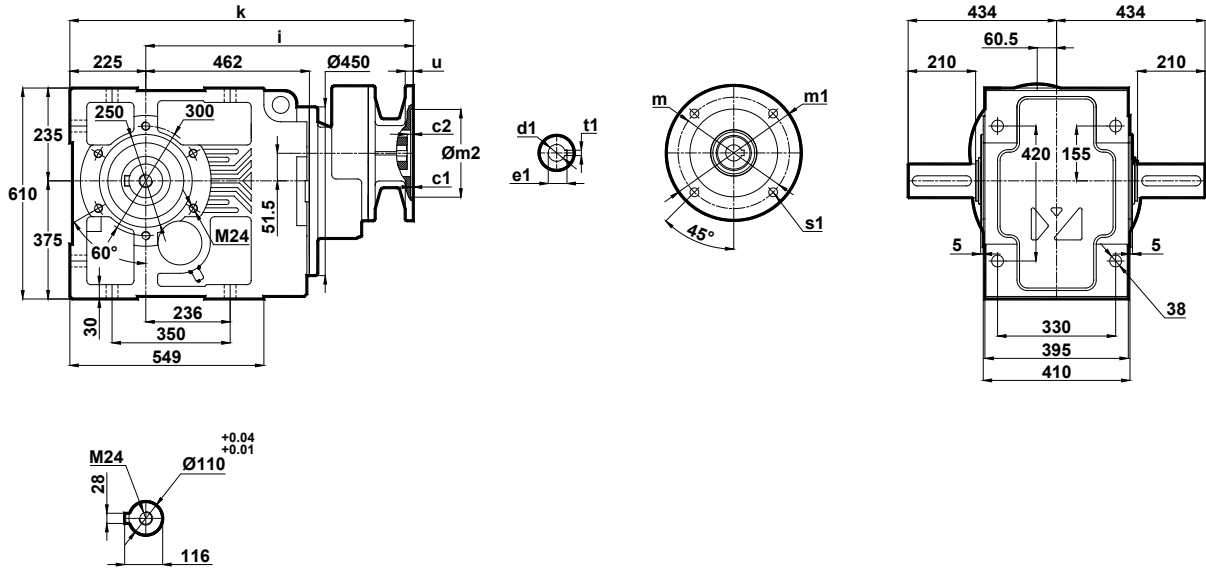

	c1	c2	s1	m	m1	m2	i	u	k	d1	t1	e1
100/B5	4.5	20	15	215	250	180	653	15	878	28	8	31.3
112/B5	4.5	20	15	215	250	180	653	15	878	28	8	31.3
132/B5	4.5	9	15	265	300	230	674	15	899	38	10	41.3
160/B5	5.5	10	19	300	350	250	749	18	974	42	12	45.3
180/B5	5.5	10	19	300	350	250	749	18	974	48	14	51.8

#### KN874.05

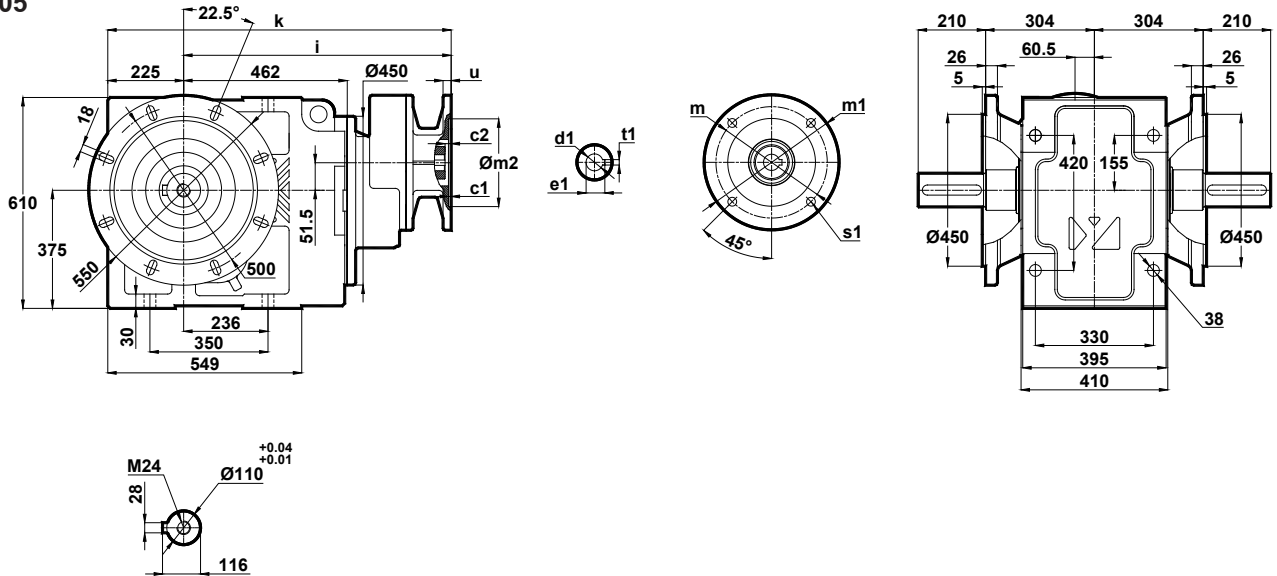

	c1	c2	s1	m	m1	m2	i	u	k	d1	t1	e1
100/B5	4.5	20	15	215	250	180	653	15	878	28	8	31.3
112/B5	4.5	20	15	215	250	180	653	15	878	28	8	31.3
132/B5	4.5	9	15	265	300	230	674	15	899	38	10	41.3
160/B5	5.5	10	19	300	350	250	749	18	974	42	12	45.3
180/B5	5.5	10	19	300	350	250	749	18	974	48	14	51.8

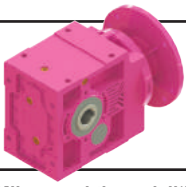

# Ölçü Sayfaları Dimension Pages Abmessungenseiten

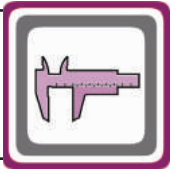

-Mil ucu çekirme deliği DIN 332 sayfa 2 / Tapped center hole to DIN 332, sheet 2 / Zentrierung mit gewinde DIN 332, Blatt 2

KN874.08

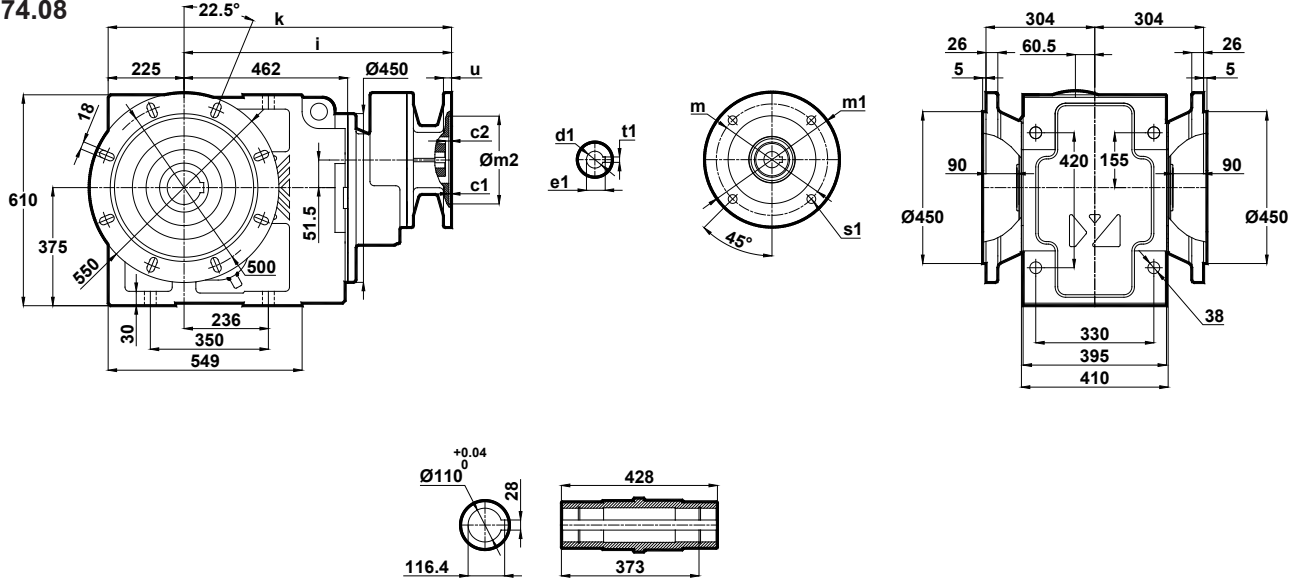

	c1	c2	s1	m	m1	m2	i	u	k	d1	t1	e1
100/B5	4.5	20	15	215	250	180	653	15	878	28	8	31.3
112/B5	4.5	20	15	215	250	180	653	15	878	28	8	31.3
132/B5	4.5	9	15	265	300	230	674	15	899	38	10	41.3
160/B5	5.5	10	19	300	350	250	749	18	974	42	12	45.3
180/B5	5.5	10	19	300	350	250	749	18	974	48	14	51.8

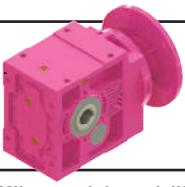

# Ölçü Sayfaları Dimension Pages Abmessungsseiten

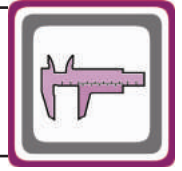

-Mil ucu çekirme deliği DIN 332 sayfa 2 / Tapped center hole to DIN 332, sheet 2 / Zentrierung mit gewinde DIN 332, Blatt 2

KN875.00  
KN876.00

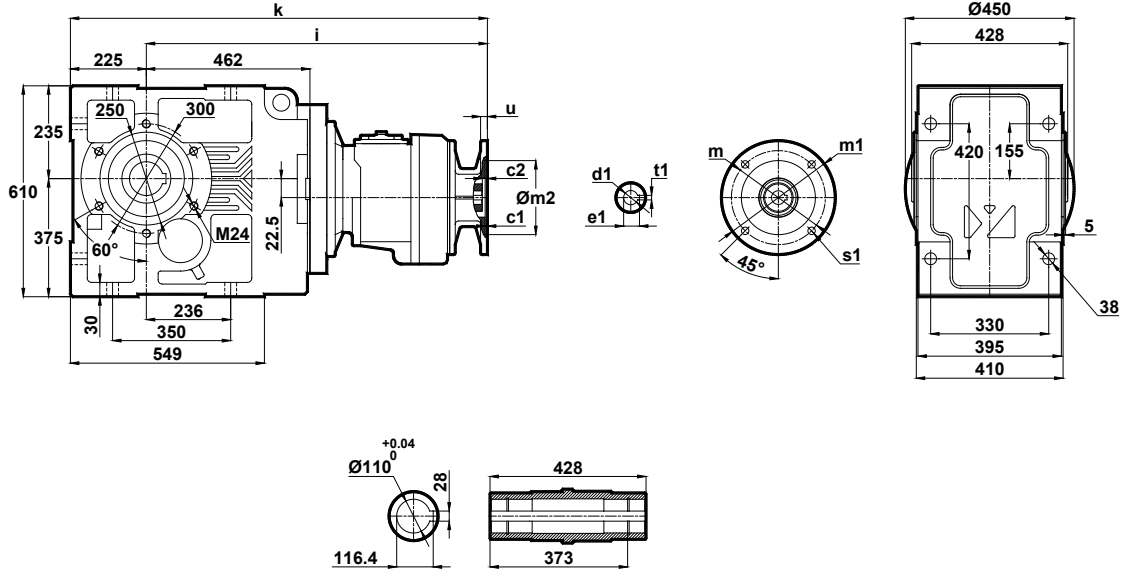

	c1	c2	s1	m	m1	m2	i	u	k	d1	t1	e1
71/B5	4	9	11	130	160	110	772	12	997	14	5	16.3
80/B5	4	9	13	165	200	130	772	12	997	19	6	21.8
90/B5	4	9	13	165	200	130	772	12	997	24	8	27.3
100/B5	4.5	9	15	215	250	180	789	15	1014	28	8	31.3
112/B5	4.5	9	15	215	250	180	789	15	1014	28	8	31.3

KN875.01  
KN876.01

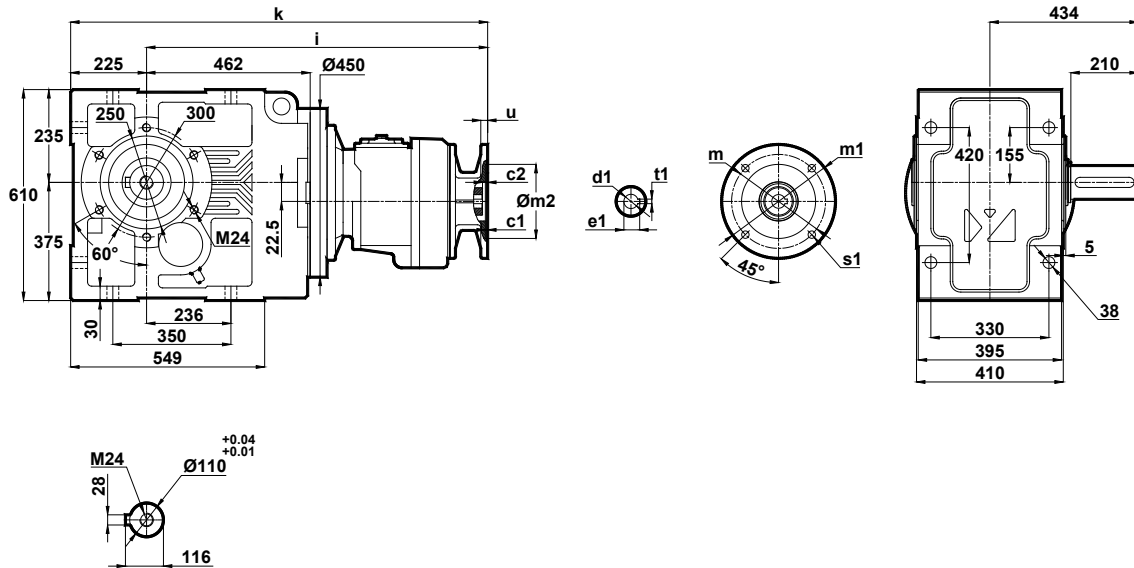

	c1	c2	s1	m	m1	m2	i	u	k	d1	t1	e1
71/B5	4	9	11	130	160	110	772	12	997	14	5	16.3
80/B5	4	9	13	165	200	130	772	12	997	19	6	21.8
90/B5	4	9	13	165	200	130	772	12	997	24	8	27.3
100/B5	4.5	9	15	215	250	180	789	15	1014	28	8	31.3
112/B5	4.5	9	15	215	250	180	789	15	1014	28	8	31.3

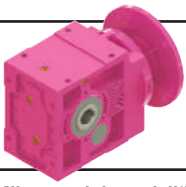

# Ölçü Sayfaları Dimension Pages Abmessungsseiten

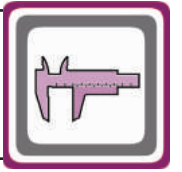

-Mil ucu çekirme deliği DIN 332 sayfa 2 / Tapped center hole to DIN 332, sheet 2 / Zentrierung mit gewinde DIN 332, Blatt 2

KN875.02  
KN876.02

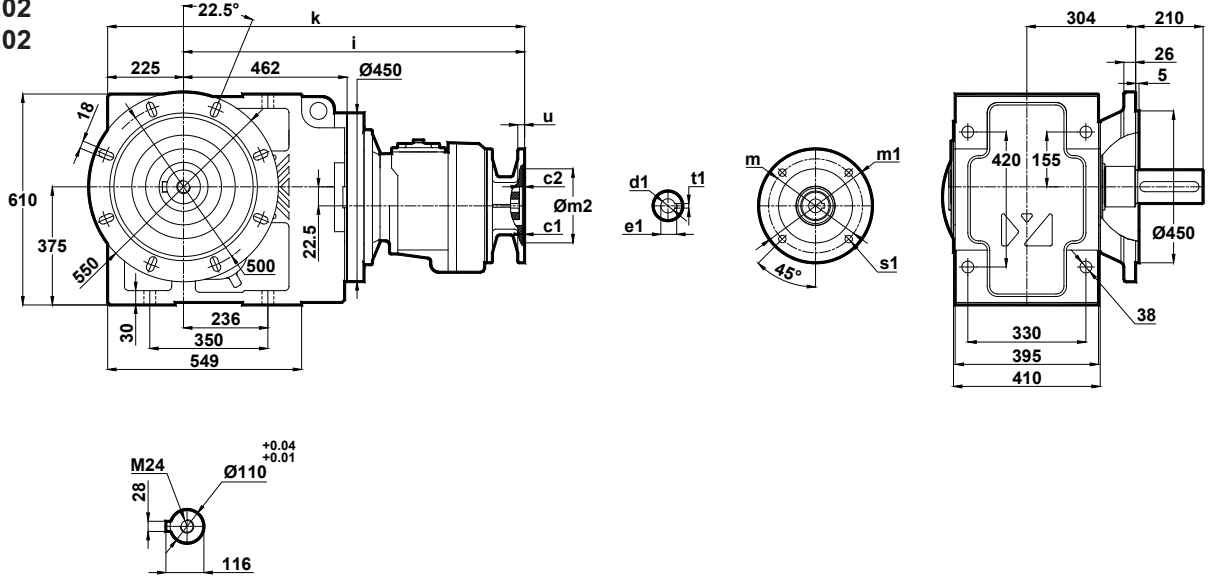

	c1	c2	s1	m	m1	m2	i	u	k	d1	t1	e1
71/B5	4	9	11	130	160	110	772	12	997	14	5	16.3
80/B5	4	9	13	165	200	130	772	12	997	19	6	21.8
90/B5	4	9	13	165	200	130	772	12	997	24	8	27.3
100/B5	4.5	9	15	215	250	180	789	15	1014	28	8	31.3
112/B5	4.5	9	15	215	250	180	789	15	1014	28	8	31.3

KN875.03  
KN876.03

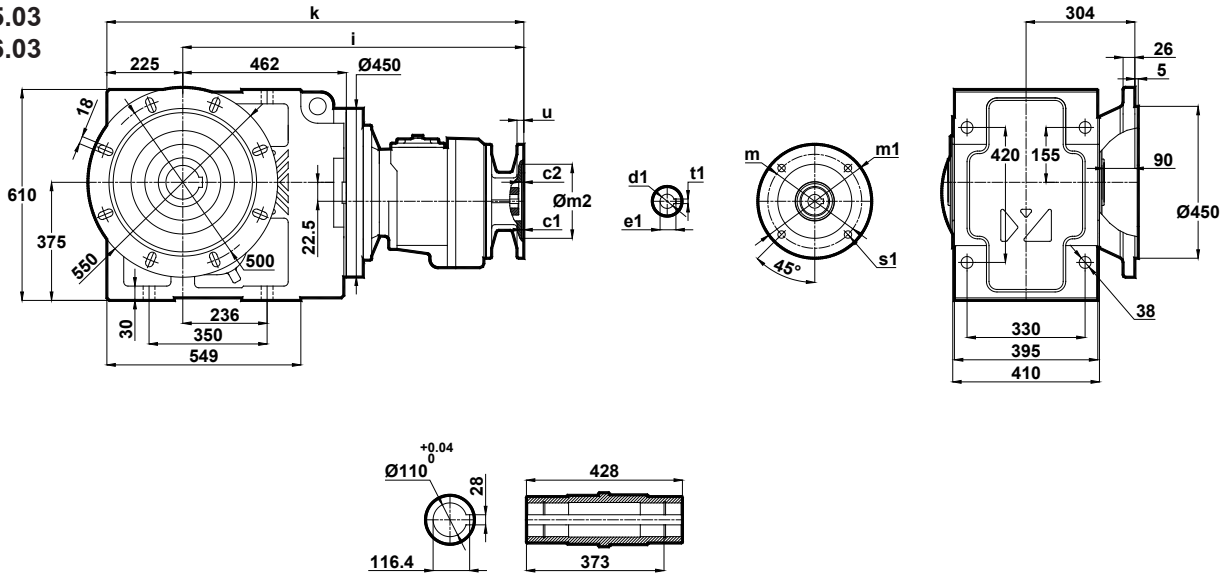

	c1	c2	s1	m	m1	m2	i	u	k	d1	t1	e1
71/B5	4	9	11	130	160	110	772	12	997	14	5	16.3
80/B5	4	9	13	165	200	130	772	12	997	19	6	21.8
90/B5	4	9	13	165	200	130	772	12	997	24	8	27.3
100/B5	4.5	9	15	215	250	180	789	15	1014	28	8	31.3
112/B5	4.5	9	15	215	250	180	789	15	1014	28	8	31.3

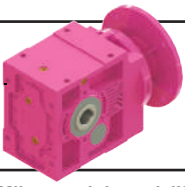

# Ölçü Sayfaları

## Dimension Pages

### Abmessungsseiten

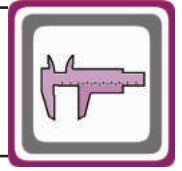

-Mil ucu çekirme deliği DIN 332 sayfa 2 / Tapped center hole to DIN 332, sheet 2 / Zentrierung mit gewinde DIN 332, Blatt 2

KN875.04  
KN876.04

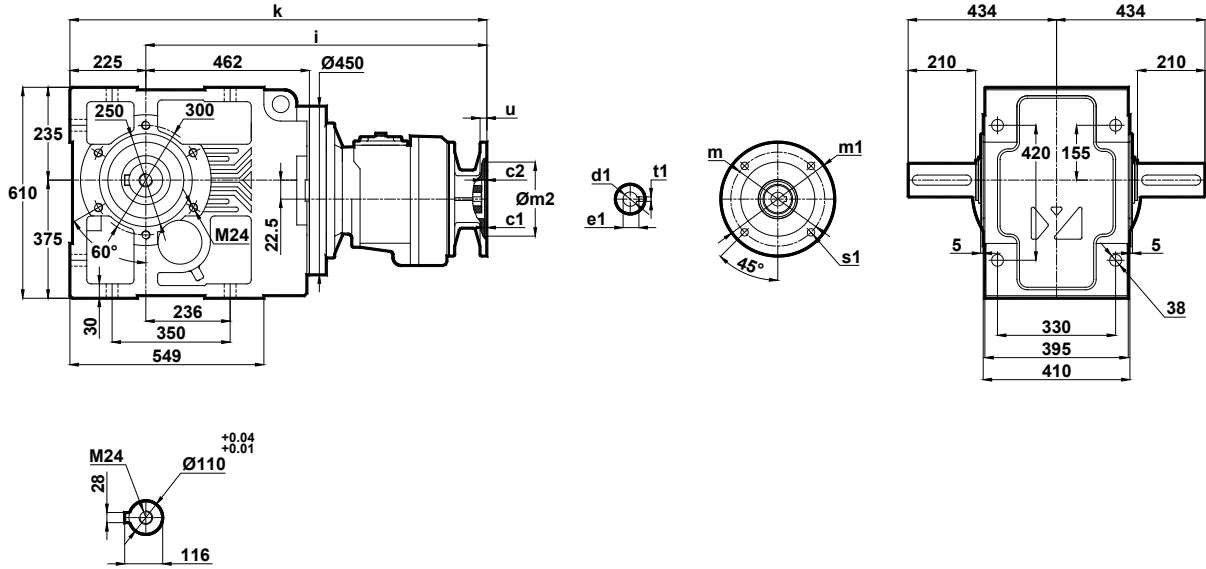

	c1	c2	s1	m	m1	m2	i	u	k	d1	t1	e1
71/B5	4	9	11	130	160	110	772	12	997	14	5	16.3
80/B5	4	9	13	165	200	130	772	12	997	19	6	21.8
90/B5	4	9	13	165	200	130	772	12	997	24	8	27.3
100/B5	4.5	9	15	215	250	180	789	15	1014	28	8	31.3
112/B5	4.5	9	15	215	250	180	789	15	1014	28	8	31.3

KN875.05  
KN876.05

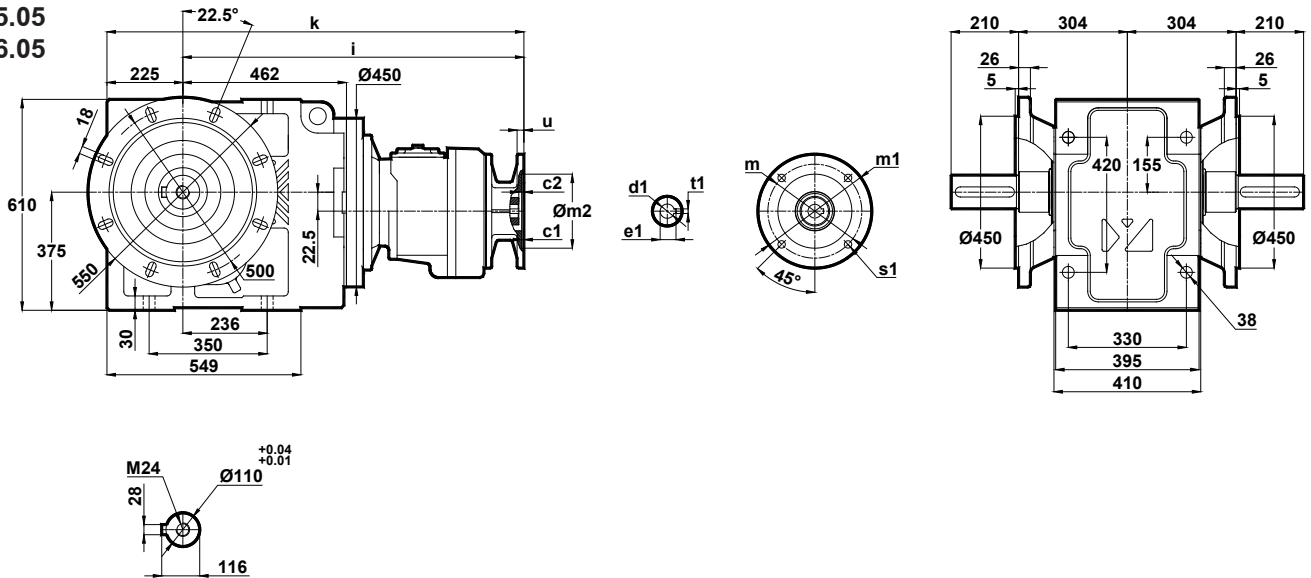

	c1	c2	s1	m	m1	m2	i	u	k	d1	t1	e1
71/B5	4	9	11	130	160	110	772	12	997	14	5	16.3
80/B5	4	9	13	165	200	130	772	12	997	19	6	21.8
90/B5	4	9	13	165	200	130	772	12	997	24	8	27.3
100/B5	4.5	9	15	215	250	180	789	15	1014	28	8	31.3
112/B5	4.5	9	15	215	250	180	789	15	1014	28	8	31.3

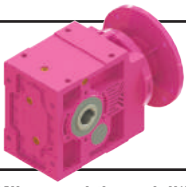

# Ölçü Sayfaları

## Dimension Pages

### Abmessungsseiten

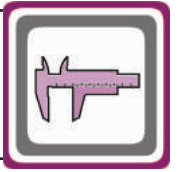

-Mil ucu çektirme deliği DIN 332 sayfa 2 / Tapped center hole to DIN 332, sheet 2 / Zentrierung mit gewinde DIN 332, Blatt 2

KN875.08  
KN876.08

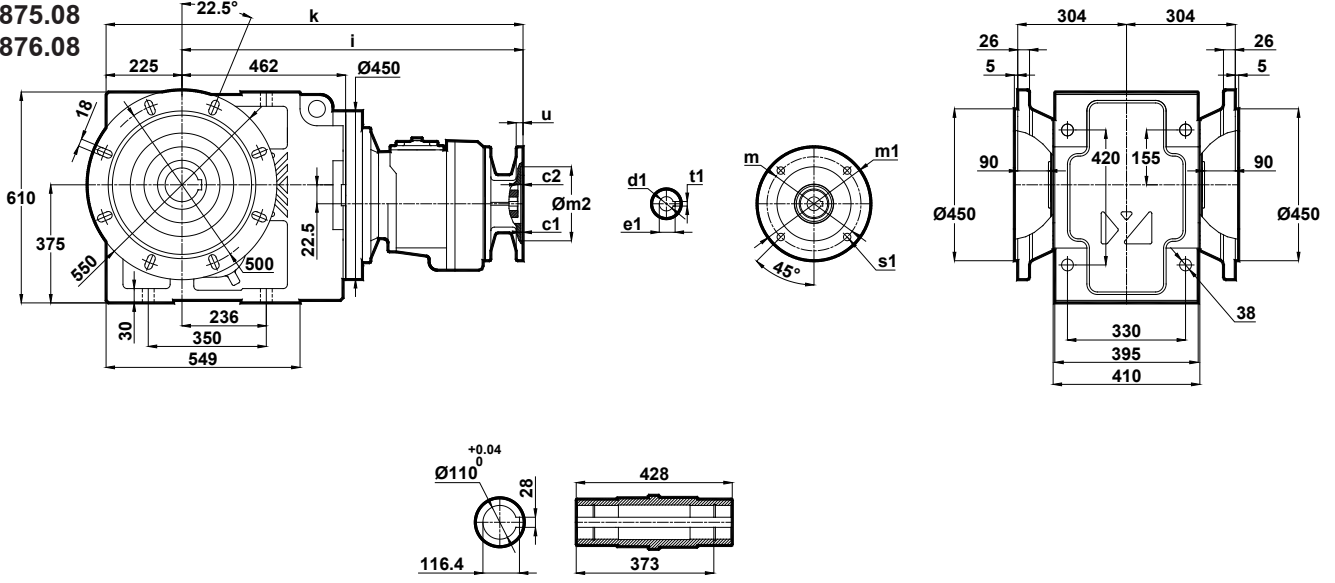

	c1	c2	s1	m	m1	m2	i	u	k	d1	t1	e1
71/B5	4	9	11	130	160	110	772	12	997	14	5	16.3
80/B5	4	9	13	165	200	130	772	12	997	19	6	21.8
90/B5	4	9	13	165	200	130	772	12	997	24	8	27.3
100/B5	4.5	9	15	215	250	180	789	15	1014	28	8	31.3
112/B5	4.5	9	15	215	250	180	789	15	1014	28	8	31.3

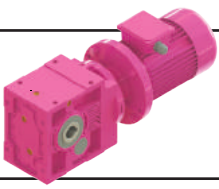

# Ölçü Sayfaları Dimension Pages Abmessungsseiten



-Mil ucu çekirme deliği DIN 332 sayfa 2 / Tapped center hole to DIN 332, sheet 2 / Zentrierung mit gewinde DIN 332, Blatt 2

KV002.00  
KV003.00

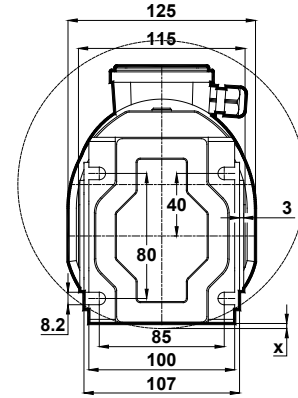
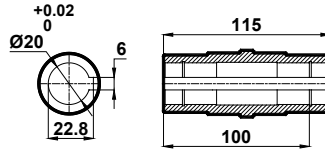
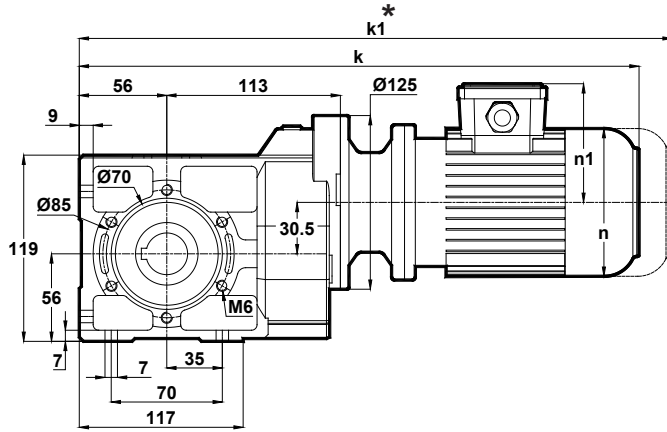

x: Motor ayak bağlantı yüzeyinin altında ise  
x: If Motor is lower then foot mounting plane  
x:Wen motor ist nidriger den die Anschlußplatte

Klemens Pozisyonları  
Terminal Box Positions  
Klemmenkasten Positionen

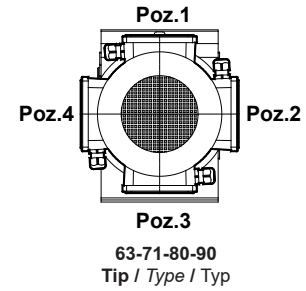

	63/B5	71/B5	80/B5	90S/B5	90L/B5
k	375	432.5	467.5	487.5	512.5
k1	428	552.5	587.5	612.5	637.5
n	116	138	156	176	176
n1	97	110	118	126	126
x	-	-	-	1.5	1.5

KV002.01  
KV003.01

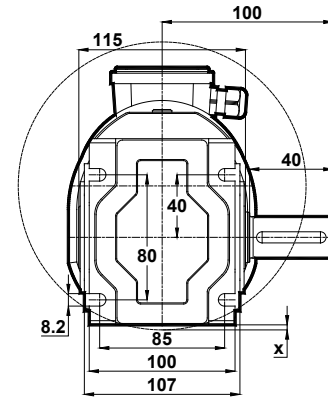
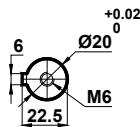
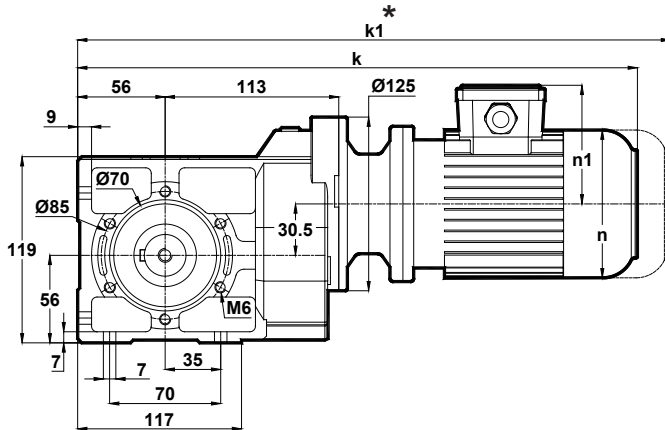

x: Motor ayak bağlantı yüzeyinin altında ise  
x: If Motor is lower then foot mounting plane  
x:Wen motor ist nidriger den die Anschlußplatte

	63/B5	71/B5	80/B5	90S/B5	90L/B5
k	375	432.5	467.5	487.5	512.5
k1	428	552.5	587.5	612.5	637.5
n	116	138	156	176	176
n1	97	110	118	126	126
x	-	-	-	1.5	1.5

\* " k1 " Ölçüsü frenli redüktörlere aittir.  
Dimension " k1 " is for motors with brake.  
Maße " k1 " ist für Bremsmotoren.

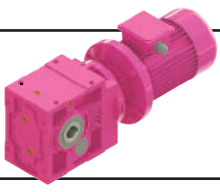

# Ölçü Sayfaları Dimension Pages Abmessungsseiten

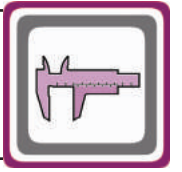

-Mil ucu çekirme deliği DIN 332 sayfa 2 / Tapped center hole to DIN 332, sheet 2 / Zentrierung mit gewinde DIN 332, Blatt 2

KV002.02  
KV003.02

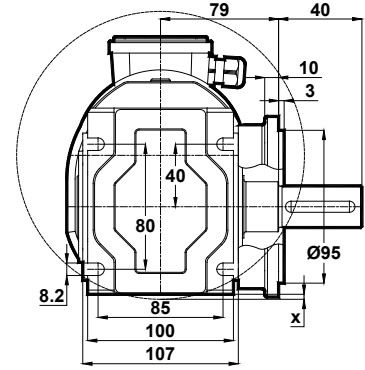
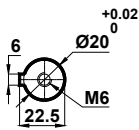
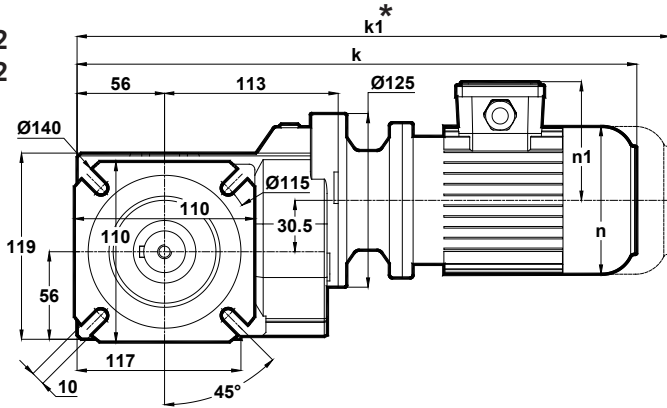

x: Motor ayak bağlantı yüzeyinin altında ise  
x: If Motor is lower then foot mounting plane  
x:Wen motor ist nidriger den die Anschlußplatte

	63/B5	71/B5	80/B5	90S/B5	90L/B5
k	375	432.5	467.5	487.5	512.5
k1	428	552.5	587.5	612.5	637.5
n	116	138	156	176	176
n1	97	110	118	126	126
x	-	-	-	1.5	1.5

Klemens Pozisyonları  
Terminal Box Positions  
Klemmenkasten Positionen

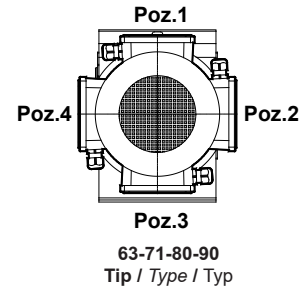

KV002.03  
KV003.03

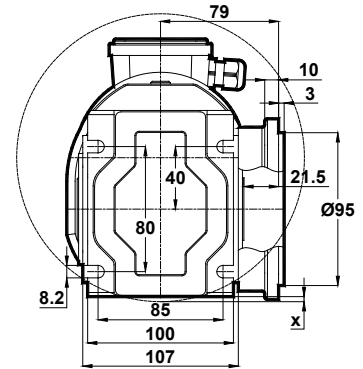
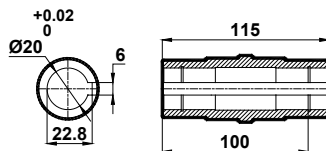
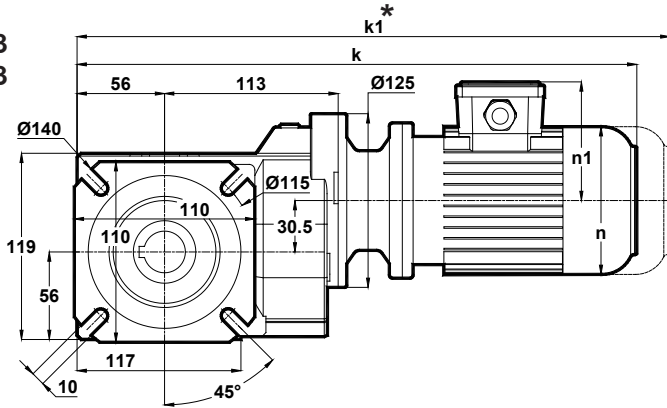

x: Motor ayak bağlantı yüzeyinin altında ise  
x: If Motor is lower then foot mounting plane  
x:Wen motor ist nidriger den die Anschlußplatte

	63/B5	71/B5	80/B5	90S/B5	90L/B5
k	375	432.5	467.5	487.5	512.5
k1	428	552.5	587.5	612.5	637.5
n	116	138	156	176	176
n1	97	110	118	126	126
x	-	-	-	1.5	1.5

\* " k1 " Ölçüsü frenli redüktörlere aittir.  
Dimension " k1 " is for motors with brake.  
Maße " k1 " ist für Bremsenmotoren.

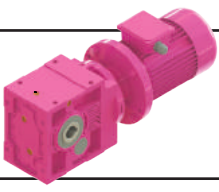

# Ölçü Sayfaları Dimension Pages Abmessungsseiten



-Mil ucu çektirme deliği DIN 332 sayfa 2 / Tapped center hole to DIN 332, sheet 2 / Zentrierung mit gewinde DIN 332, Blatt 2

KV002.04  
KV003.04

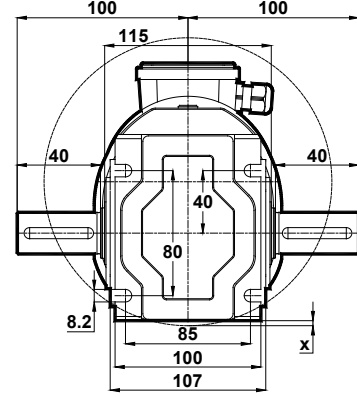
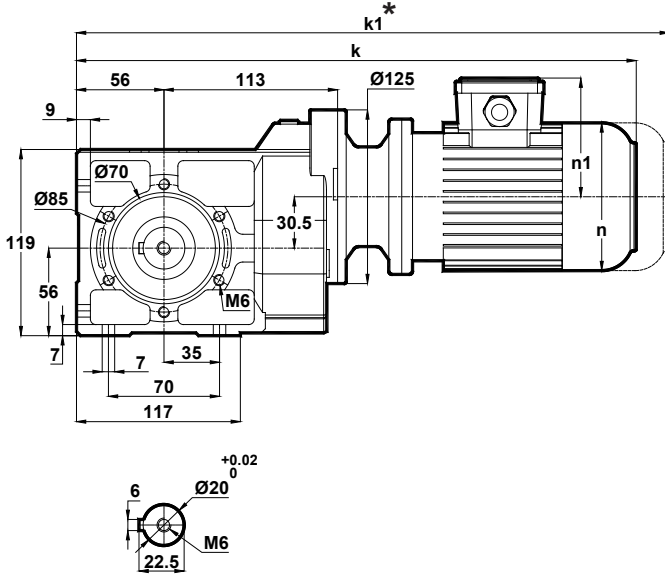

x: Motor Ayak bağlantı yüzeyinin altında ise  
x: If Motor is lower then foot mounting plane  
x:Wen motor ist nidriger den die Anschlußplatte

Klemens Pozisyonları  
Terminal Box Positions  
Klemmenkasten Positionen

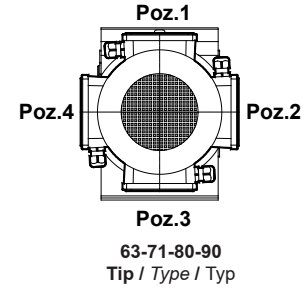

	63/B5	71/B5	80/B5	90S/B5	90L/B5
k	375	432.5	467.5	487.5	512.5
k1	428	552.5	587.5	612.5	637.5
n	116	138	156	176	176
n1	97	110	118	126	126
x	-	-	-	1.5	1.5

KV002.05  
KV003.05

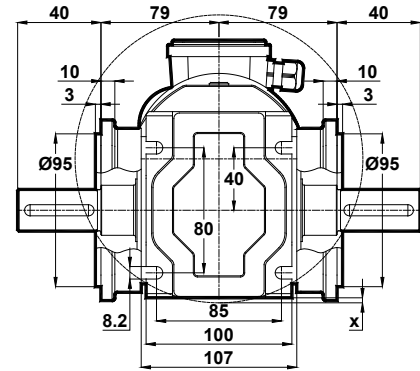
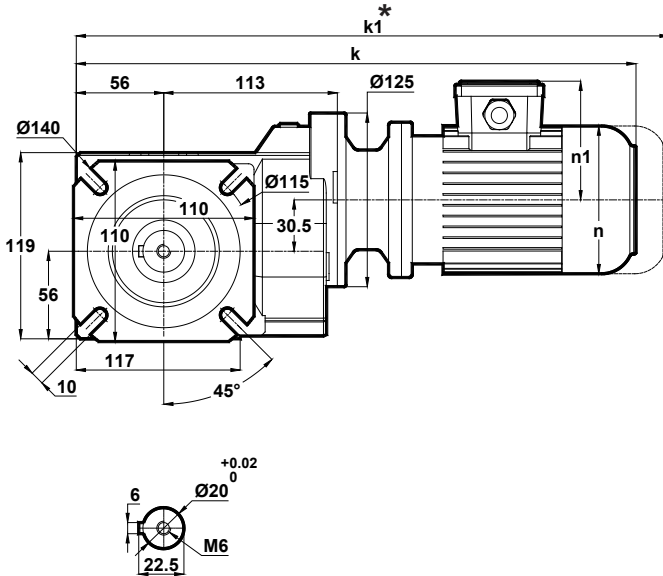

x: Motor Ayak bağlantı yüzeyinin altında ise  
x: If Motor is lower then foot mounting plane  
x:Wen motor ist nidriger den die Anschlußplatte

	63/B5	71/B5	80/B5	90S/B5	90L/B5
k	375	432.5	467.5	487.5	512.5
k1	428	552.5	587.5	612.5	637.5
n	116	138	156	176	176
n1	97	110	118	126	126
x	-	-	-	1.5	1.5

\* " k1 " Ölçüsü frenli redüktörlere aittir.  
Dimension " k1 " is for motors with brake.  
Maße " k1 " ist für Bremsmotoren.

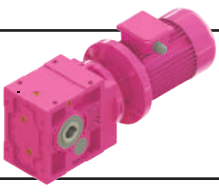

# Ölçü Sayfaları Dimension Pages Abmessungsseiten

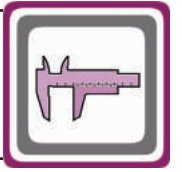

-Mil ucu çekirme deliği DIN 332 sayfa 2 / Tapped center hole to DIN 332, sheet 2 / Zentrierung mit gewinde DIN 332, Blatt 2

KV002.08  
KV003.08

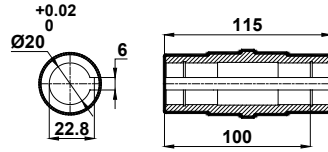
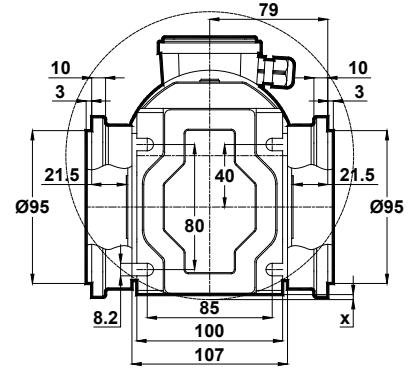
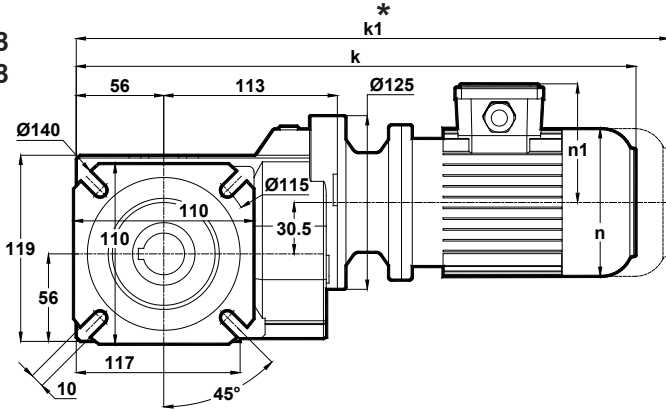

x: Motor ayak bağlantı yüzeyinin altında ise  
x: If Motor is lower then foot mounting plane  
x: Wenn motor ist niedriger den die Anschlußplatte

Klemens Pozisyonları  
Terminal Box Positions  
Klemmenkasten Positionen

	63/B5	71/B5	80/B5	90S/B5	90L/B5
k	375	432.5	467.5	487.5	512.5
k1	428	552.5	587.5	612.5	637.5
n	116	138	156	176	176
n1	97	110	118	126	126
x	-	-	-	1.5	1.5

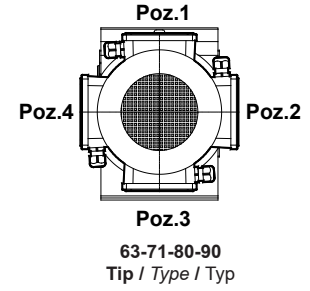

\* " k1 " Ölçüsü frenli redüktörlere aittir.  
Dimension " k1 " is for motors with brake.  
Maße " k1 " ist für Bremsenmotoren.

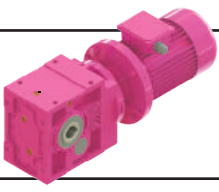

# Ölçü Sayfaları Dimension Pages Abmessungsseiten



-Mil ucu çekirme deliği DIN 332 sayfa 2 / Tapped center hole to DIN 332, sheet 2 / Zentrierung mit gewinde DIN 332, Blatt 2

KV102.00  
KV103.00

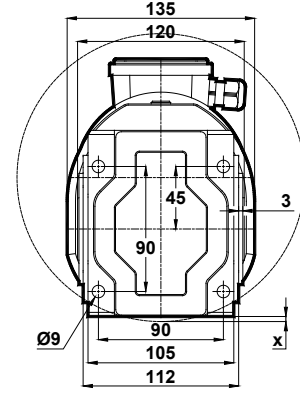
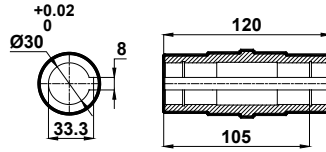
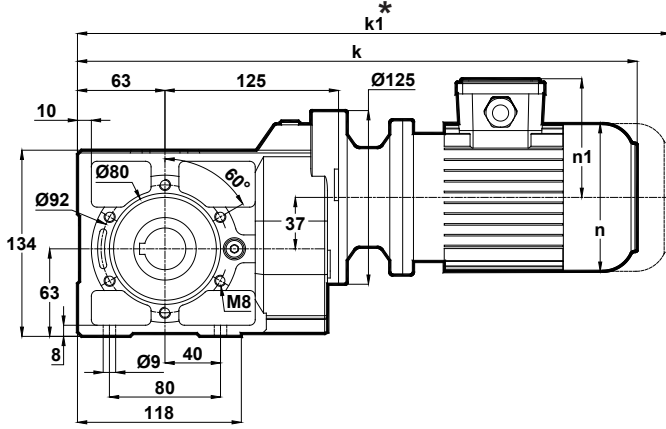

x: Motor ayak bağlantı yüzeyinin altında ise  
x: If Motor is lower then foot mounting plane  
x:Wen motor ist nidriger den die Anschlußplatte

	63/B5	71/B5	80/B5	90S/B5	90L/B5
k	394	451.5	486.5	506.5	531.5
k1	447	571.5	606.5	631.5	656.5
n	116	138	156	176	176
n1	97	110	118	126	126
x	-	-	-	-	-

Klemens Pozisyonları  
Terminal Box Positions  
Klemmenkasten Positionen

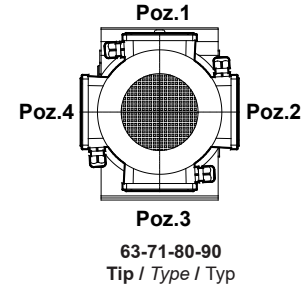

KV102.01  
KV103.01

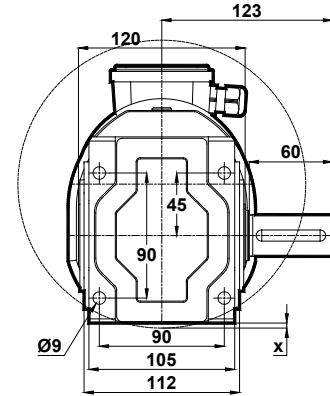
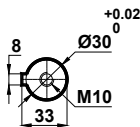
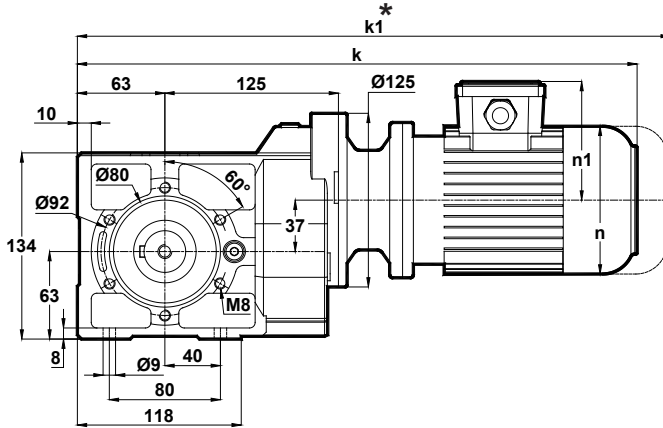

x: Motor ayak bağlantı yüzeyinin altında ise  
x: If Motor is lower then foot mounting plane  
x:Wen motor ist nidriger den die Anschlußplatte

	63/B5	71/B5	80/B5	90S/B5	90L/B5
k	394	451.5	486.5	506.5	531.5
k1	447	571.5	606.5	631.5	656.5
n	116	138	156	176	176
n1	97	110	118	126	126
x	-	-	-	-	-

\* "k1" Ölçüsü frenli redüktörlere aittir.  
Dimension "k1" is for motors with brake.  
Maße "k1" ist für Bremsenmotoren.

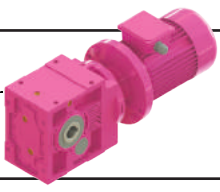

# Ölçü Sayfaları Dimension Pages Abmessungsseiten

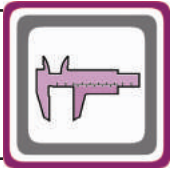

-Mil ucu çektirme deliği DIN 332 sayfa 2 / Tapped center hole to DIN 332, sheet 2 / Zentrierung mit gewinde DIN 332, Blatt 2

KV102.02  
KV103.02

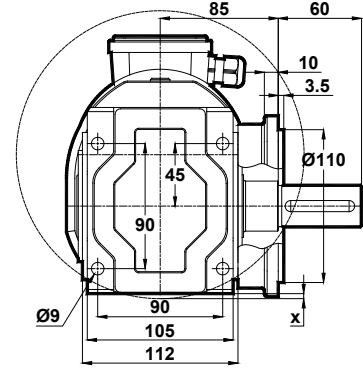
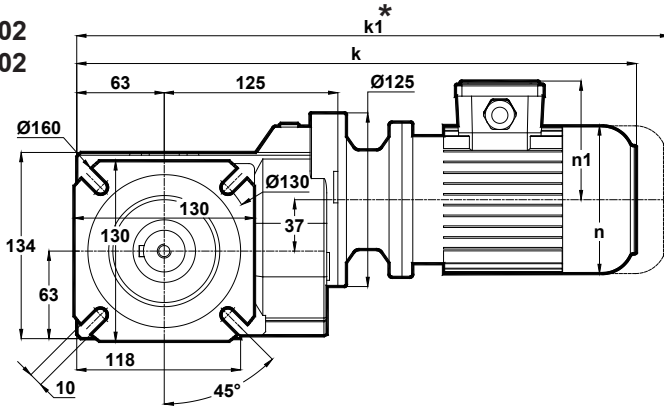

x: Motor Ayak bağlantı yüzeyinin altında ise  
x: If Motor is lower then foot mounting plane  
x: Wenn motor ist niedriger den die Anschlußplatte

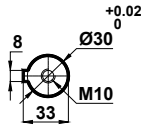

	63/B5	71/B5	80/B5	90S/B5	90L/B5
k	394	451.5	486.5	506.5	531.5
k1	447	571.5	606.5	631.5	656.5
n	116	138	156	176	176
n1	97	110	118	126	126
x	-	-	-	-	-

Klemens Pozisyonları  
Terminal Box Positions  
Klemmenkasten Positionen

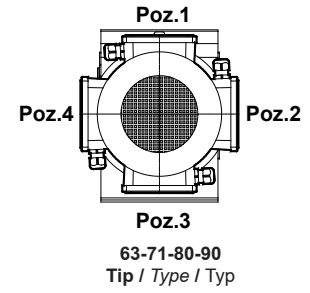

KV102.03  
KV103.03

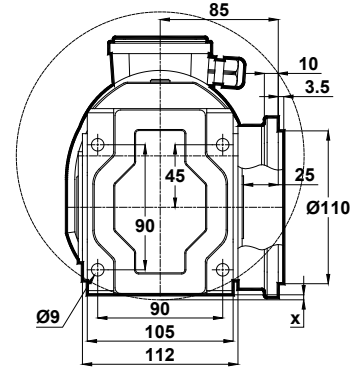
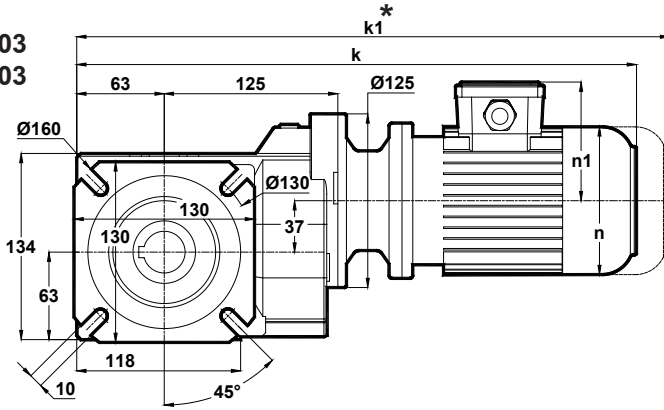

x: Motor Ayak bağlantı yüzeyinin altında ise  
x: If Motor is lower then foot mounting plane  
x: Wenn motor ist niedriger den die Anschlußplatte

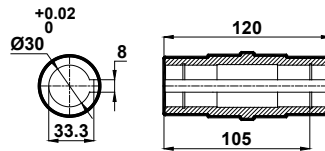

	63/B5	71/B5	80/B5	90S/B5	90L/B5
k	394	451.5	486.5	506.5	531.5
k1	447	571.5	606.5	631.5	656.5
n	116	138	156	176	176
n1	97	110	118	126	126
x	-	-	-	-	-

\* " k1 " Ölçüsü frenli redüktörlere aittir.  
Dimension " k1 " is for motors with brake.  
Maße " k1 " ist für Bremsenmotoren.

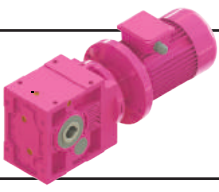

# Ölçü Sayfaları Dimension Pages Abmessungsseiten



-Mil ucu çektirme deliği DIN 332 sayfa 2 / Tapped center hole to DIN 332, sheet 2 / Zentrierung mit gewinde DIN 332, Blatt 2

KV102.04  
KV103.04

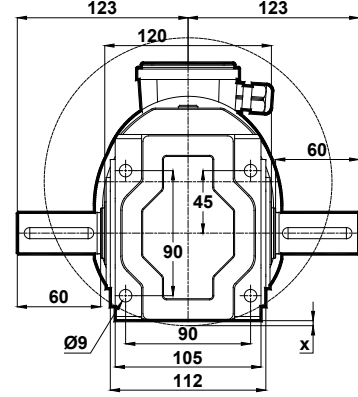
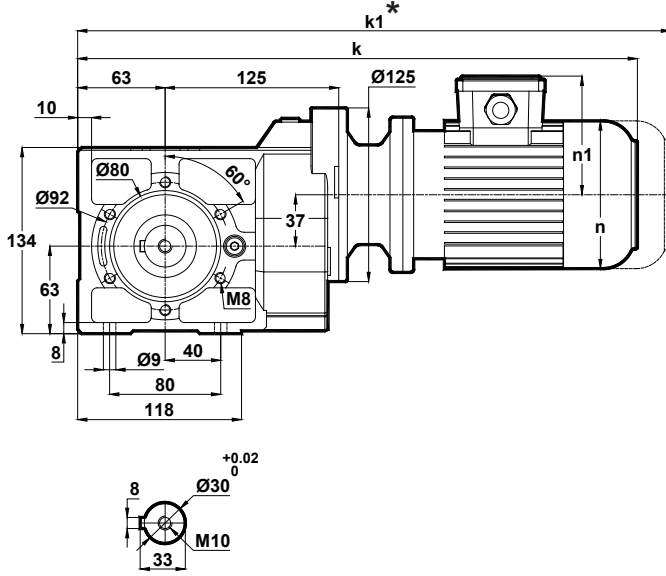

x: Motor Ayak bağlantı yüzeyinin altında ise  
x: If Motor is lower then foot mounting plane  
x:Wen motor ist nidriger den die Anschlußplatte

Klemens Pozisyonları  
Terminal Box Positions  
Klemmenkasten Positionen

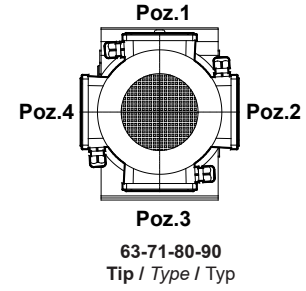

	63/B5	71/B5	80/B5	90S/B5	90L/B5
k	394	451.5	486.5	506.5	531.5
k1	447	571.5	606.5	631.5	656.5
n	116	138	156	176	176
n1	97	110	118	126	126
x	-	-	-	-	-

KV102.05  
KV103.05

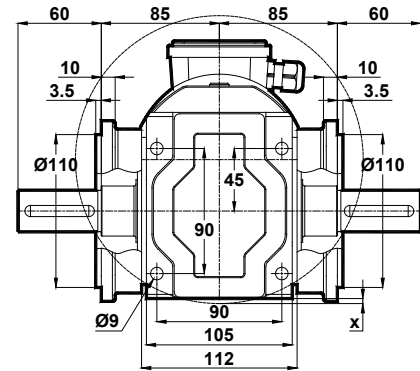
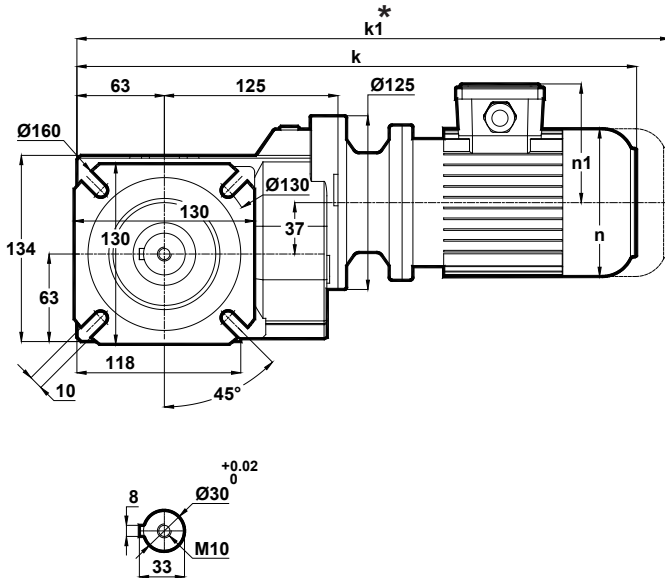

x: Motor Ayak bağlantı yüzeyinin altında ise  
x: If Motor is lower then foot mounting plane  
x:Wen motor ist nidriger den die Anschlußplatte

	63/B5	71/B5	80/B5	90S/B5	90L/B5
k	394	451.5	486.5	506.5	531.5
k1	447	571.5	606.5	631.5	656.5
n	116	138	156	176	176
n1	97	110	118	126	126
x	-	-	-	-	-

\* " k1 " Ölçüsü frenli redüktörlere aittir.  
Dimension " k1 " is for motors with brake.  
Maße " k1 " ist für Bremsmotoren.

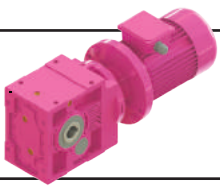

# Ölçü Sayfaları Dimension Pages Abmessungsseiten

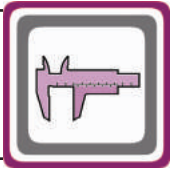

-Mil ucu çekirme deliği DIN 332 sayfa 2 / Tapped center hole to DIN 332, sheet 2 / Zentrierung mit gewinde DIN 332, Blatt 2

KV102.08  
KV103.08

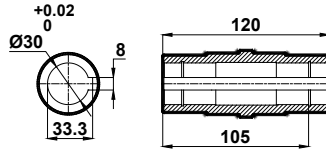
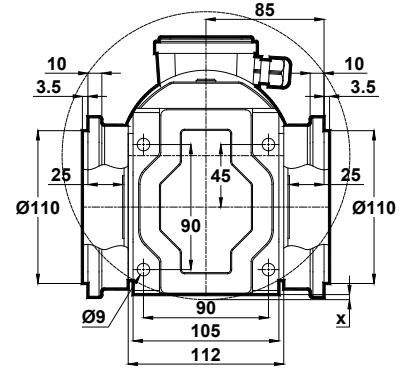
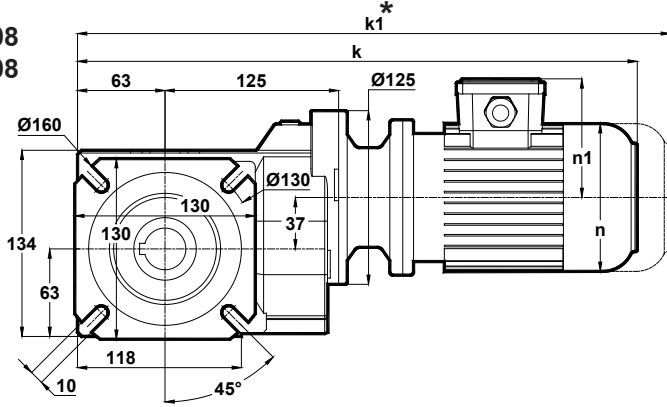

x: Motor ayak bağlantı yüzeyinin altında ise  
x: If Motor is lower then foot mounting plane  
x: Wenn motor ist niedriger den die Anschlußplatte

Klemens Pozisyonları  
Terminal Box Positions  
Klemmenkasten Positionen

	63/B5	71/B5	80/B5	90S/B5	90L/B5
k	394	451.5	486.5	506.5	531.5
k1	447	571.5	606.5	631.5	656.5
n	116	138	156	176	176
n1	97	110	118	126	126
x	-	-	-	-	-

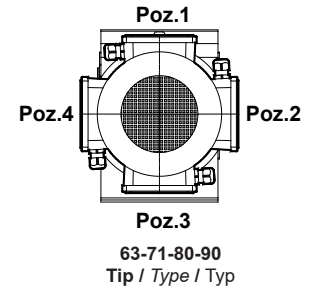

\* " k1 " Ölçüsü frenli redüktörlere aittir.  
Dimension " k1 " is for motors with brake.  
Maße " k1 " ist für Bremsenmotoren.



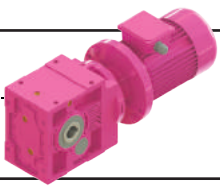

# Ölçü Sayfaları Dimension Pages Abmessungsseiten

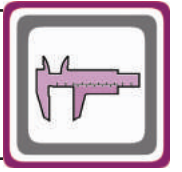

-Mil ucu çektirme deliği DIN 332 sayfa 2 / Tapped center hole to DIN 332, sheet 2 / Zentrierung mit gewinde DIN 332, Blatt 2

KV202.02  
KV203.02

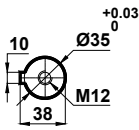
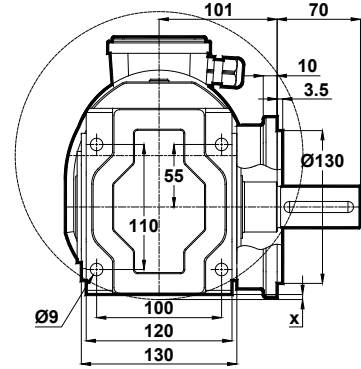
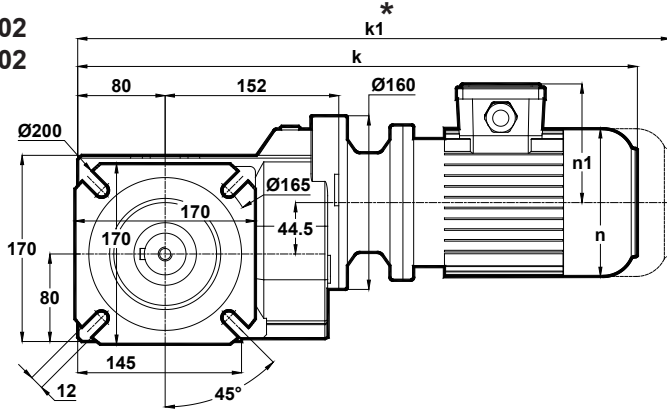

x: Motor Ayak bağlantı yüzeyinin altında ise  
x: If Motor is lower then foot mounting plane  
x: Wenn motor ist niedriger den die Anschlußplatte

Klemens Pozisyonları  
Terminal Box Positions  
Klemmenkasten Positionen

	63/B5	71/B5	80/B5	90S/B5	90L/B5	100L/B5	112M/B5
k	468.5	495.5	544.5	564.5	589.5	614.5	634.5
k1	521.5	615.5	664.5	689.5	714.5	749.5	769.5
n	116	138	156	176	176	194	218
n1	97	110	118	126	126	135	146
x	-	-	-	-	-	-	-

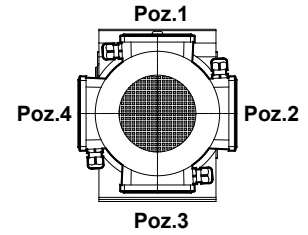

63-71-80-90-100-112  
Tip / Type / Typ

KV202.03  
KV203.03

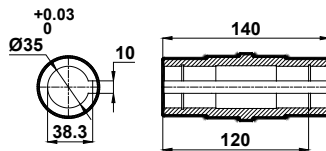
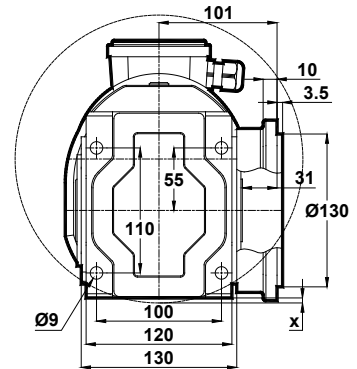
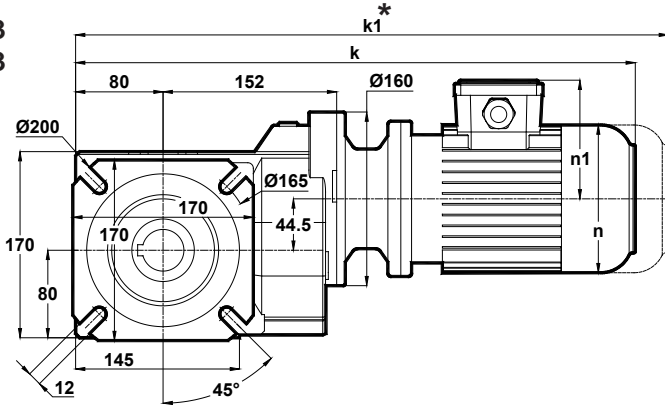

x: Motor Ayak bağlantı yüzeyinin altında ise  
x: If Motor is lower then foot mounting plane  
x: Wenn motor ist niedriger den die Anschlußplatte

	63/B5	71/B5	80/B5	90S/B5	90L/B5	100L/B5	112M/B5
k	468.5	495.5	544.5	564.5	589.5	614.5	634.5
k1	521.5	615.5	664.5	689.5	714.5	749.5	769.5
n	116	138	156	176	176	194	218
n1	97	110	118	126	126	135	146
x	-	-	-	-	-	-	-

\* " k1 " Ölçüsü frenli redüktörlere aittir.  
Dimension " k1 " is for motors with brake.  
Maße " k1 " ist für Bremsenmotoren.

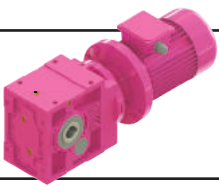

# Ölçü Sayfaları Dimension Pages Abmessungsseiten



-Mil ucu çektirme deliği DIN 332 sayfa 2 / Tapped center hole to DIN 332, sheet 2 / Zentrierung mit gewinde DIN 332, Blatt 2

KV202.04  
KV203.04

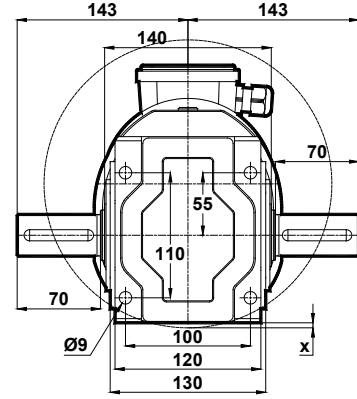
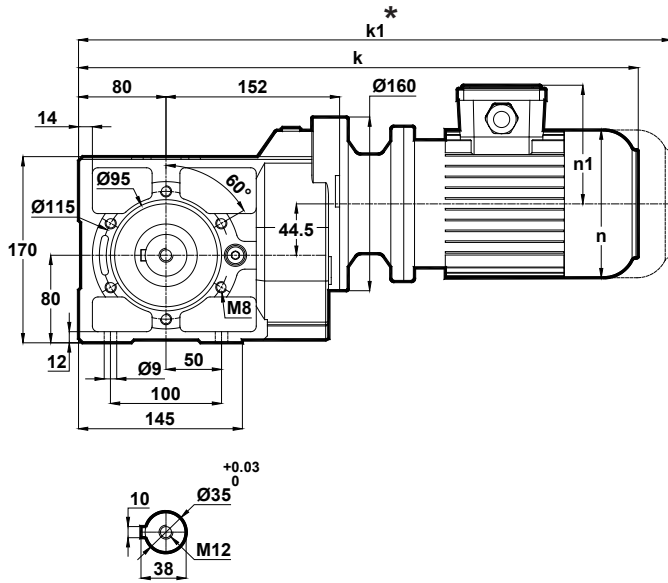

x: Motor Ayak bağlantı yüzeyinin altında ise  
x: If Motor is lower then foot mounting plane  
x:Wen motor ist nidriger den die Anschlußplatte

Klemens Pozisyonları  
Terminal Box Positions  
Klemmenkasten Positionen

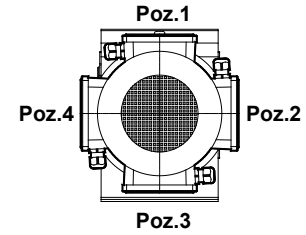

63-71-80-90-100-112  
Tip / Type / Typ

	63/B5	71/B5	80/B5	90S/B5	90L/B5	100L/B5	112M/B5
k	468.5	495.5	544.5	564.5	589.5	614.5	634.5
k1	521.5	615.5	664.5	689.5	714.5	749.5	769.5
n	116	138	156	176	176	194	218
n1	97	110	118	126	126	135	146
x	-	-	-	-	-	-	-

KV202.05  
KV203.05

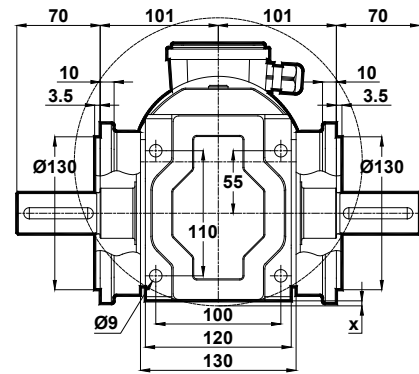
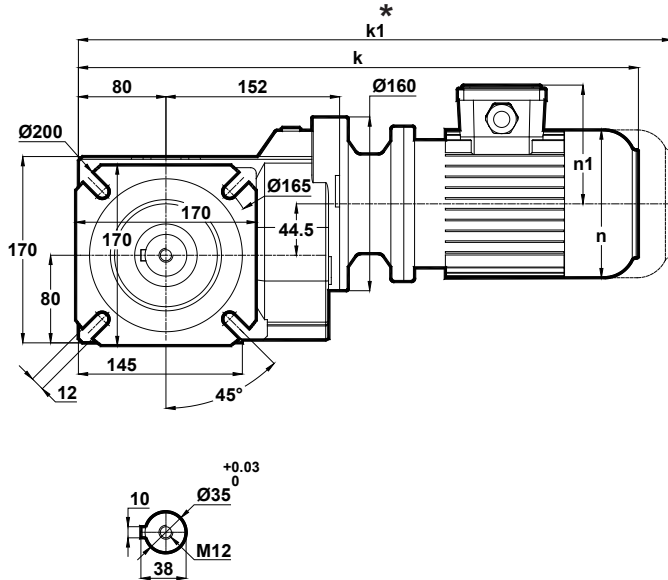

x: Motor Ayak bağlantı yüzeyinin altında ise  
x: If Motor is lower then foot mounting plane  
x:Wen motor ist nidriger den die Anschlußplatte

	63/B5	71/B5	80/B5	90S/B5	90L/B5	100L/B5	112M/B5
k	468.5	495.5	544.5	564.5	589.5	614.5	634.5
k1	521.5	615.5	664.5	689.5	714.5	749.5	769.5
n	116	138	156	176	176	194	218
n1	97	110	118	126	126	135	146
x	-	-	-	-	-	-	-

\* " k1 " Ölçüsü frenli redüktörlere aittir.  
Dimension " k1 " is for motors with brake.  
Maße " k1 " ist für Bremsenmotoren.

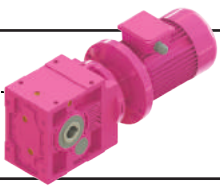

# Ölçü Sayfaları Dimension Pages Abmessungsseiten

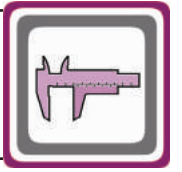

-Mil ucu çekirme deliği DIN 332 sayfa 2 / Tapped center hole to DIN 332, sheet 2 / Zentrierung mit gewinde DIN 332, Blatt 2

KV202.08  
KV203.08

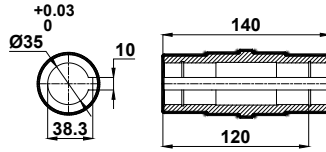
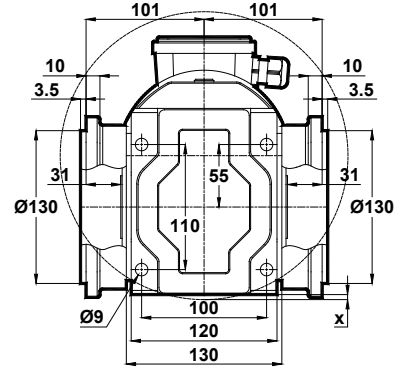
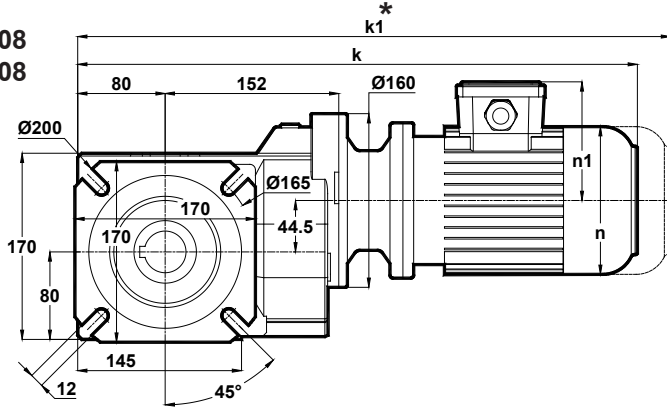

x: Motor Ayak bağlantı yüzeyinin altında ise  
x: If Motor is lower then foot mounting plane  
x: Wenn motor ist niedriger den die Anschlußplatte

Klemens Pozisyonları  
Terminal Box Positions  
Klemmenkasten Positionen

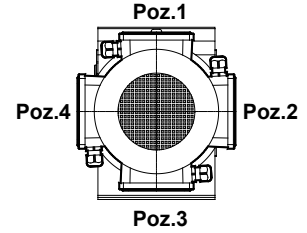

63-71-80-90-100-112  
Tip / Type / Typ

	63/B5	71/B5	80/B5	90S/B5	90L/B5	100L/B5	112M/B5
k	468.5	495.5	544.5	564.5	589.5	614.5	634.5
k1	521.5	615.5	664.5	689.5	714.5	749.5	769.5
n	116	138	156	176	176	194	218
n1	97	110	118	126	126	135	146
x	-	-	-	-	-	-	-

\* " k1 " Ölçüsü frenli redüktörlere aittir.  
Dimension " k1 " is for motors with brake.  
Maße " k1 " ist für Bremsenmotoren.

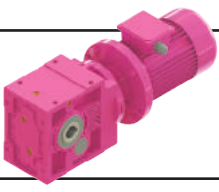

# Ölçü Sayfaları Dimension Pages Abmessungsseiten



-Mil ucu çektirme deliği DIN 332 sayfa 2 / Tapped center hole to DIN 332, sheet 2 / Zentrierung mit gewinde DIN 332, Blatt 2

## KV273.00

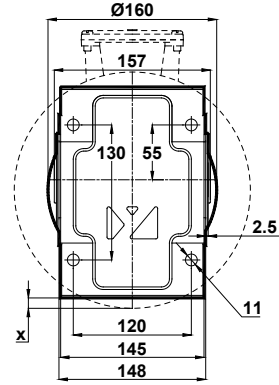
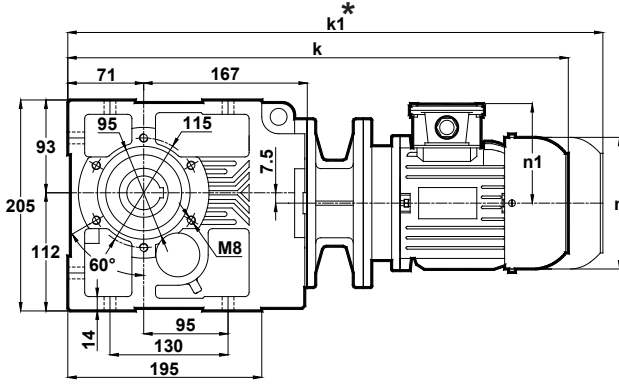

x: Motor Ayak bağlantı yüzeyinin altında ise  
x: If Motor is lower then foot mounting plane  
x: Wenn motor ist niedriger den die Anschlußplatte

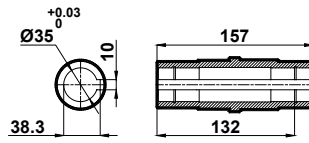

Klemens Pozisyonları  
Terminal Box Positions  
Klemmenkasten Positionen

	63/B5	71/B5	80/B5	90S/B5	90L/B5	100L/B5	112M/B5
k	505	502	551	571	596	621	641
k1	-	622	671	696	721	756	776
n	116	138	156	176	176	194	218
n1	97	110	118	126	126	135	146
x	-	-	-	-	-	-	4.5

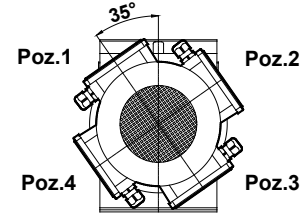

63-71-80-90-100-112  
Tip / Type / Typ

## KV273.01

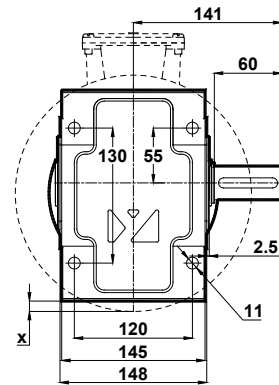
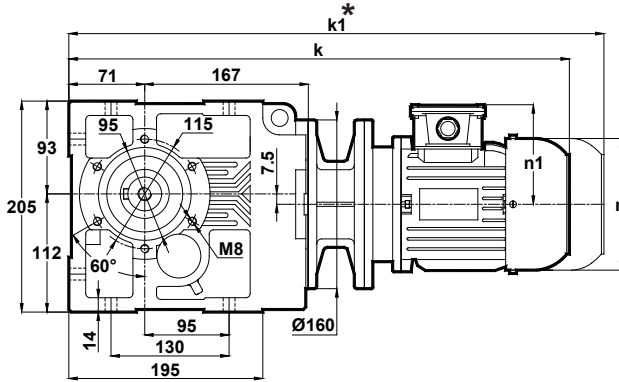

x: Motor Ayak bağlantı yüzeyinin altında ise  
x: If Motor is lower then foot mounting plane  
x: Wenn motor ist niedriger den die Anschlußplatte

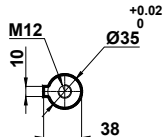

	63/B5	71/B5	80/B5	90S/B5	90L/B5	100L/B5	112M/B5
k	505	502	551	571	596	621	641
k1	-	622	671	696	721	756	776
n	116	138	156	176	176	194	218
n1	97	110	118	126	126	135	146
x	-	-	-	-	-	-	4.5

\* " k1 " Ölçüsü frenli redüktörlere aittir.  
Dimension " k1 " is for motors with brake.  
Maße " k1 " ist für Bremsenmotoren.

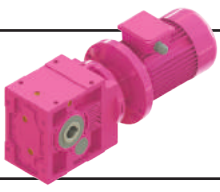

# Ölçü Sayfaları Dimension Pages Abmessungsseiten

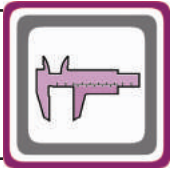

-Mil ucu çekirme deliği DIN 332 sayfa 2 / Tapped center hole to DIN 332, sheet 2 / Zentrierung mit gewinde DIN 332, Blatt 2

## KV273.02

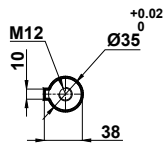
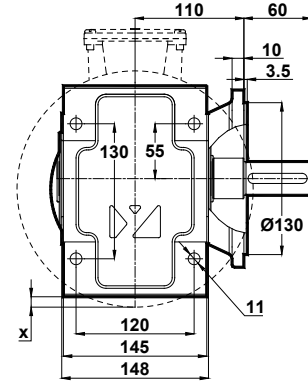
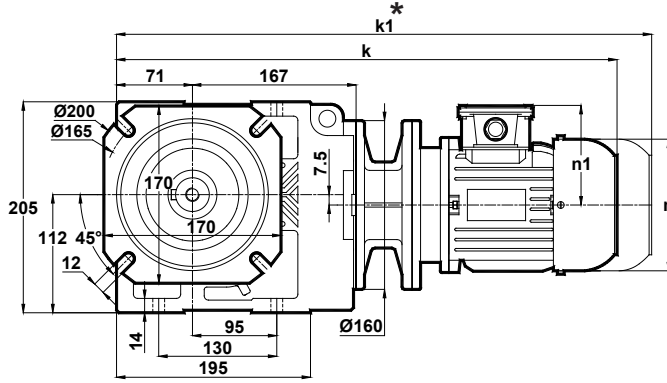

x: Motor Ayak bağlantı yüzeyinin altında ise  
x: If Motor is lower then foot mounting plane  
x:Wen motor ist nidriger den die Anschlußplatte

Klemens Pozisyonları  
Terminal Box Positions  
Klemmenkasten Positionen

	63/B5	71/B5	80/B5	90S/B5	90L/B5	100L/B5	112M/B5
k	505	502	551	571	596	621	641
k1	-	622	671	696	721	756	776
n	116	138	156	176	176	194	218
n1	97	110	118	126	126	135	146
x	-	-	-	-	-	-	4.5

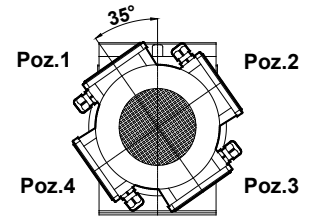

63-71-80-90-100-112  
Tip / Type / Typ

## KV273.03

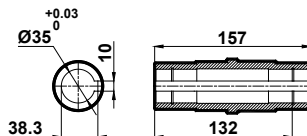
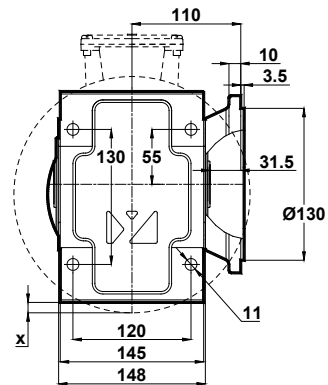
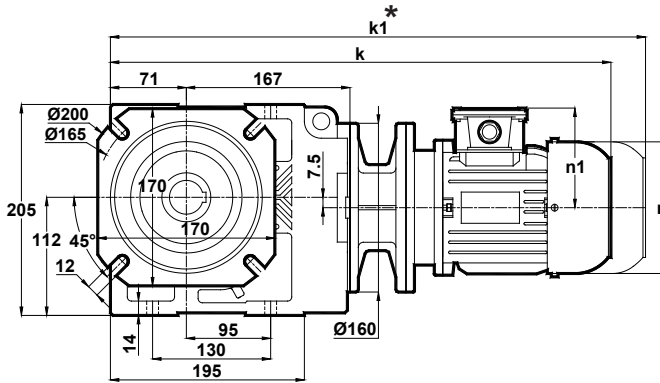

x: Motor Ayak bağlantı yüzeyinin altında ise  
x: If Motor is lower then foot mounting plane  
x:Wen motor ist nidriger den die Anschlußplatte

	63/B5	71/B5	80/B5	90S/B5	90L/B5	100L/B5	112M/B5
k	505	502	551	571	596	621	641
k1	-	622	671	696	721	756	776
n	116	138	156	176	176	194	218
n1	97	110	118	126	126	135	146
x	-	-	-	-	-	-	4.5

\* " k1 " Ölçüsü frenli redüktörlere aittir.  
Dimension " k1 " is for motors with brake.  
Maße " k1 " ist für Bremsenmotoren.

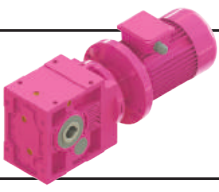

# Ölçü Sayfaları Dimension Pages Abmessungsseiten



-Mil ucu çektirme deliği DIN 332 sayfa 2 / Tapped center hole to DIN 332, sheet 2 / Zentrierung mit gewinde DIN 332, Blatt 2

## KV273.04

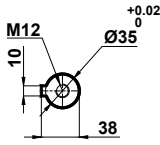
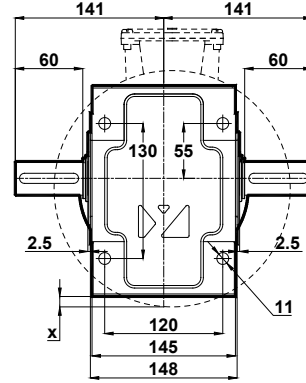
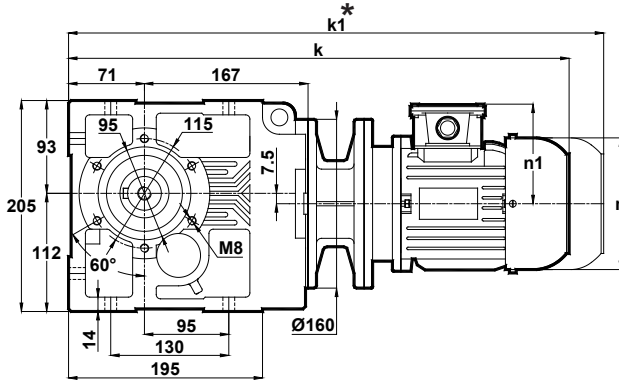

x: Motor Ayak bağlantı yüzeyinin altında ise  
x: If Motor is lower then foot mounting plane  
x: Wenn motor ist niedriger den die Anschlußplatte

Klemens Pozisyonları  
Terminal Box Positions  
Klemmenkasten Positionen

	63/B5	71/B5	80/B5	90S/B5	90L/B5	100L/B5	112M/B5
k	505	502	551	571	596	621	641
k1	-	622	671	696	721	756	776
n	116	138	156	176	176	194	218
n1	97	110	118	126	126	135	146
x	-	-	-	-	-	-	4.5

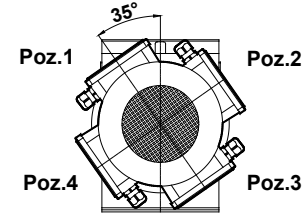

63-71-80-90-100-112  
Tip / Type / Typ

## KV273.05

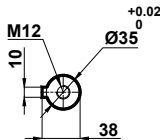
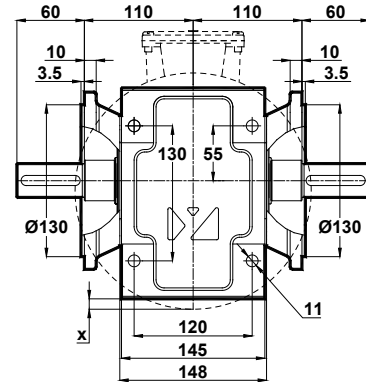
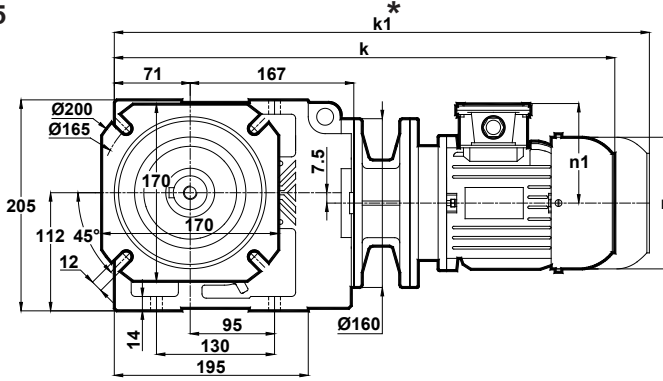

x: Motor Ayak bağlantı yüzeyinin altında ise  
x: If Motor is lower then foot mounting plane  
x: Wenn motor ist niedriger den die Anschlußplatte

	63/B5	71/B5	80/B5	90S/B5	90L/B5	100L/B5	112M/B5
k	505	502	551	571	596	621	641
k1	-	622	671	696	721	756	776
n	116	138	156	176	176	194	218
n1	97	110	118	126	126	135	146
x	-	-	-	-	-	-	4.5

\* " k1 " Ölçüsü frenli redüktörlere aittir.  
Dimension " k1 " is for motors with brake.  
Maße " k1 " ist für Bremsmotoren.

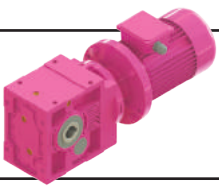

# Ölçü Sayfaları Dimension Pages Abmessungsseiten

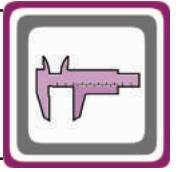

-Mil ucu çekirme deliği DIN 332 sayfa 2 / Tapped center hole to DIN 332, sheet 2 / Zentrierung mit gewinde DIN 332, Blatt 2

KV273.08

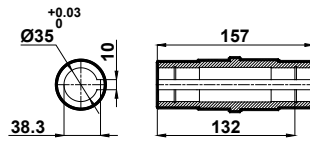
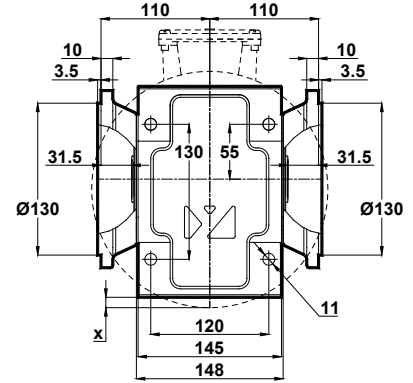
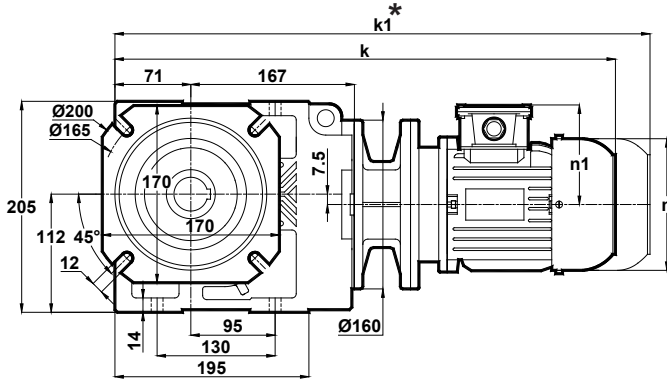

x: Motor Ayak bağlantı yüzeyinin altında ise  
x: If Motor is lower then foot mounting plane  
x: Wenn motor ist niedriger den die Anschlußplatte

Klemens Pozisyonları  
Terminal Box Positions  
Klemmenkasten Positionen

	63/B5	71/B5	80/B5	90S/B5	90L/B5	100L/B5	112M/B5
k	505	502	551	571	596	621	641
k1	-	622	671	696	721	756	776
n	116	138	156	176	176	194	218
n1	97	110	118	126	126	135	146
x	-	-	-	-	-	-	4.5

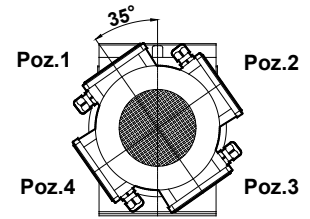

63-71-80-90-100-112  
Tip / Type / Typ

\* " k1 " Ölçüsü frenli redüktörlere aittir.  
Dimension " k1 " is for motors with brake.  
Maße " k1 " ist für Bremsenmotoren.

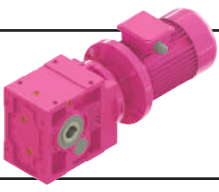

# Ölçü Sayfaları Dimension Pages Abmessungsseiten



-Mil ucu çekirme deliği DIN 332 sayfa 2 / Tapped center hole to DIN 332, sheet 2 / Zentrierung mit gewinde DIN 332, Blatt 2

KV275.00  
KV276.00

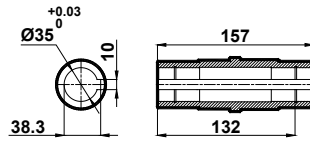
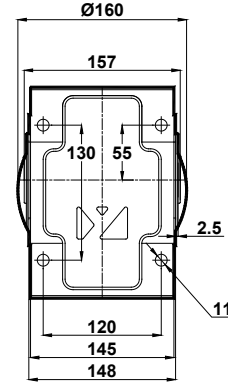
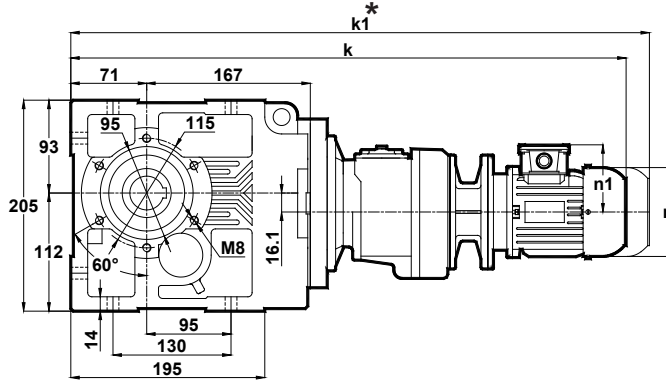

	63/B5	71/B5	80/B5
k	620	648	683
k1	-	768	803
n	116	138	156
n1	97	110	118

Klemens Pozisyonları  
Terminal Box Positions  
Klemmenkasten Positionen

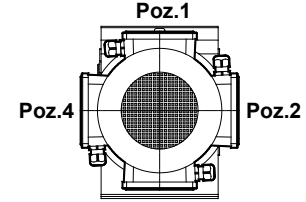

Poz.3  
63-71-80  
Tip / Type / Typ

KV275.01  
KV276.01

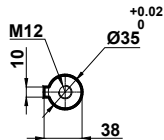
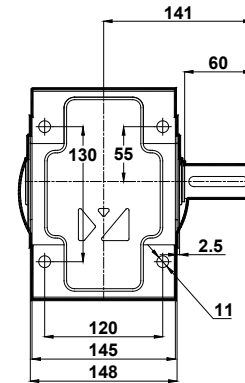
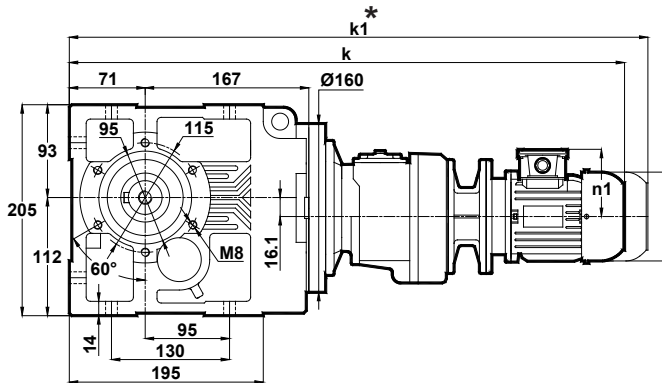

	63/B5	71/B5	80/B5
k	620	648	683
k1	-	768	803
n	116	138	156
n1	97	110	118

\* "k1" Ölçüsü frenli redüktörlere aittir.  
Dimension "k1" is for motors with brake.  
Maße "k1" ist für Bremsenmotoren.

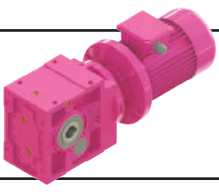

# Ölçü Sayfaları Dimension Pages Abmessungsseiten

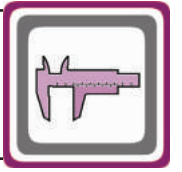

-Mil ucu çektirme deliği DIN 332 sayfa 2 / Tapped center hole to DIN 332, sheet 2 / Zentrierung mit gewinde DIN 332, Blatt 2

KV275.02  
KV276.02

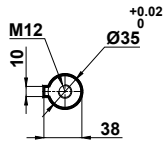
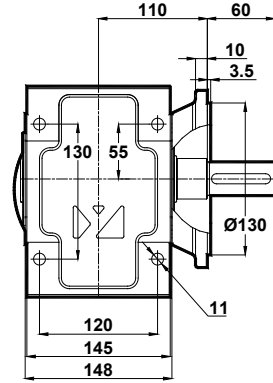
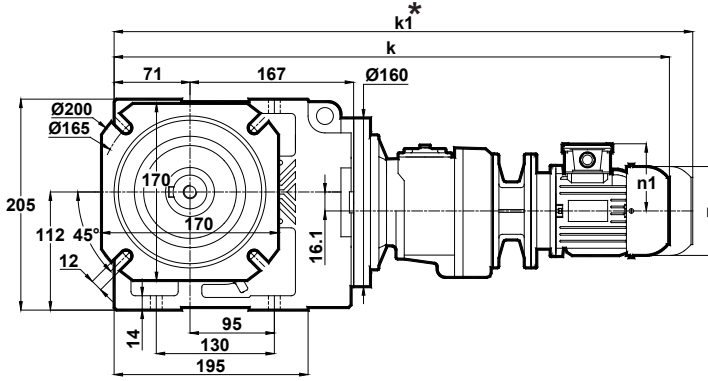

	63/B5	71/B5	80/B5
k	620	648	683
k1	-	768	803
n	116	138	156
n1	97	110	118

Klemens Pozisyonları  
Terminal Box Positions  
Klemmenkasten Positionen

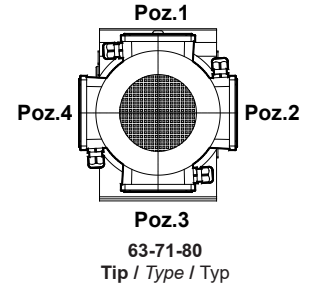

KV275.03  
KV276.03

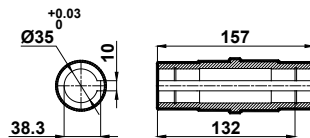
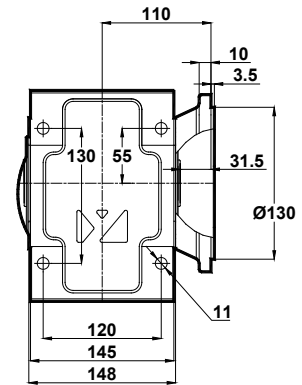
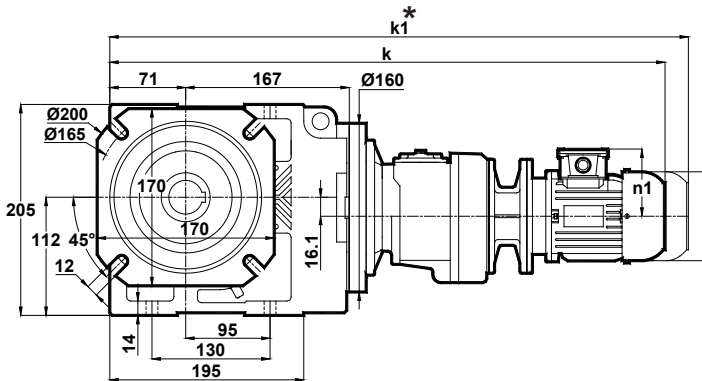

	63/B5	71/B5	80/B5
k	620	648	683
k1	-	768	803
n	116	138	156
n1	97	110	118

\* " k1 " Ölçüsü frenli redüktörlere aittir.  
Dimension " k1 " is for motors with brake.  
Maße " k1 " ist für Bremsenmotoren.

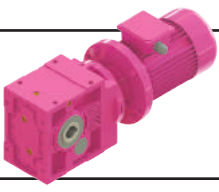

# Ölçü Sayfaları Dimension Pages Abmessungsseiten



-Mil ucu çekirme deliği DIN 332 sayfa 2 / Tapped center hole to DIN 332, sheet 2 / Zentrierung mit gewinde DIN 332, Blatt 2

KV275.04  
KV276.04

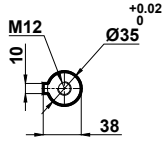
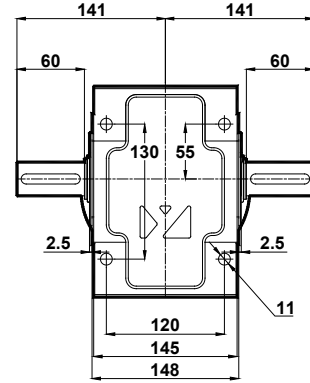
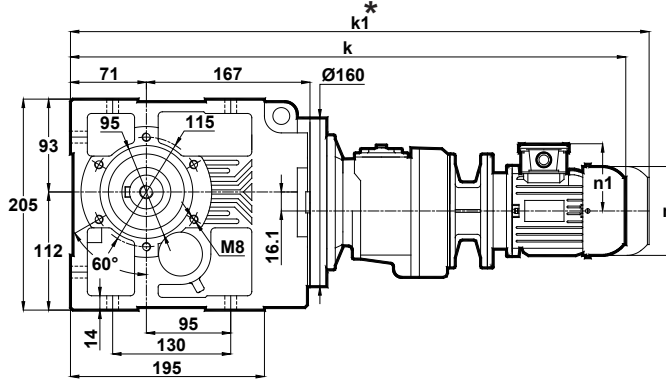

	63/B5	71/B5	80/B5
k	620	648	683
k1	-	768	803
n	116	138	156
n1	97	110	118

Klemens Pozisyonları  
Terminal Box Positions  
Klemmenkasten Positionen

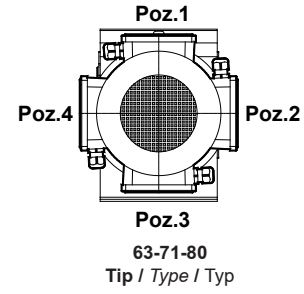

KV275.05  
KV276.05

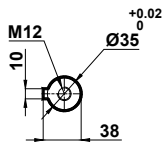
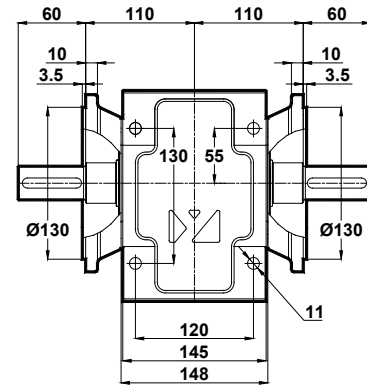
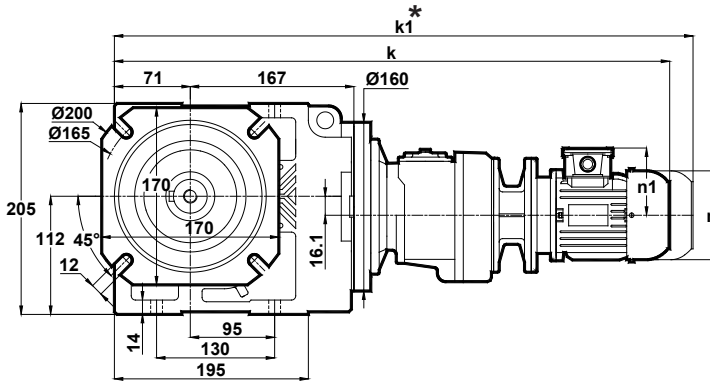

	63/B5	71/B5	80/B5
k	620	648	683
k1	-	768	803
n	116	138	156
n1	97	110	118

\* "k1" Ölçüsü frenli redüktörlere aittir.  
Dimension "k1" is for motors with brake.  
Maße "k1" ist für Bremsenmotoren.

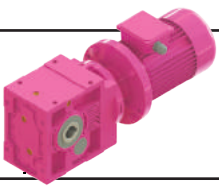

# Ölçü Sayfaları Dimension Pages Abmessungenseiten

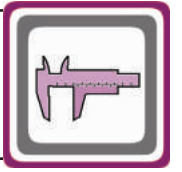

-Mil ucu çekirme deliği DIN 332 sayfa 2 / Tapped center hole to DIN 332, sheet 2 / Zentrierung mit gewinde DIN 332, Blatt 2

KV275.08  
KV276.08

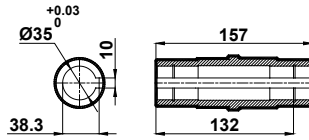
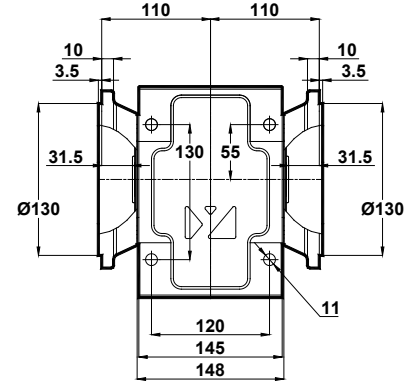
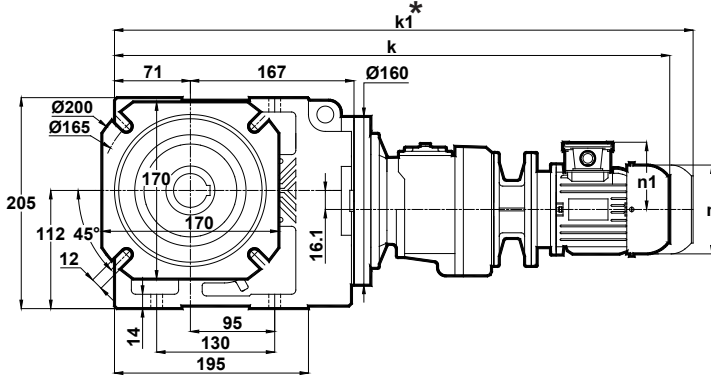

	63/B5	71/B5	80/B5
k	620	648	683
k1	-	768	803
n	116	138	156
n1	97	110	118

Klemens Pozisyonları  
Terminal Box Positions  
Klemmenkasten Positionen

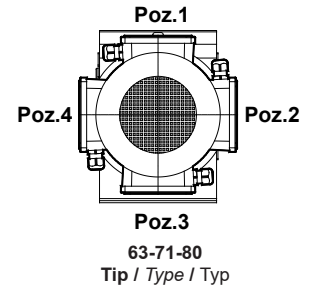

\* " k1 " Ölçüsü frenli redüktörlere aittir.  
Dimension " k1 " is for motors with brake.  
Maße " k1 " ist für Bremsenmotoren.

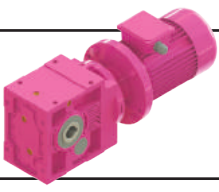

# Ölçü Sayfaları Dimension Pages Abmessungsseiten



-Mil ucu çekirme deliği DIN 332 sayfa 2 / Tapped center hole to DIN 332, sheet 2 / Zentrierung mit gewinde DIN 332, Blatt 2

## KV373.00

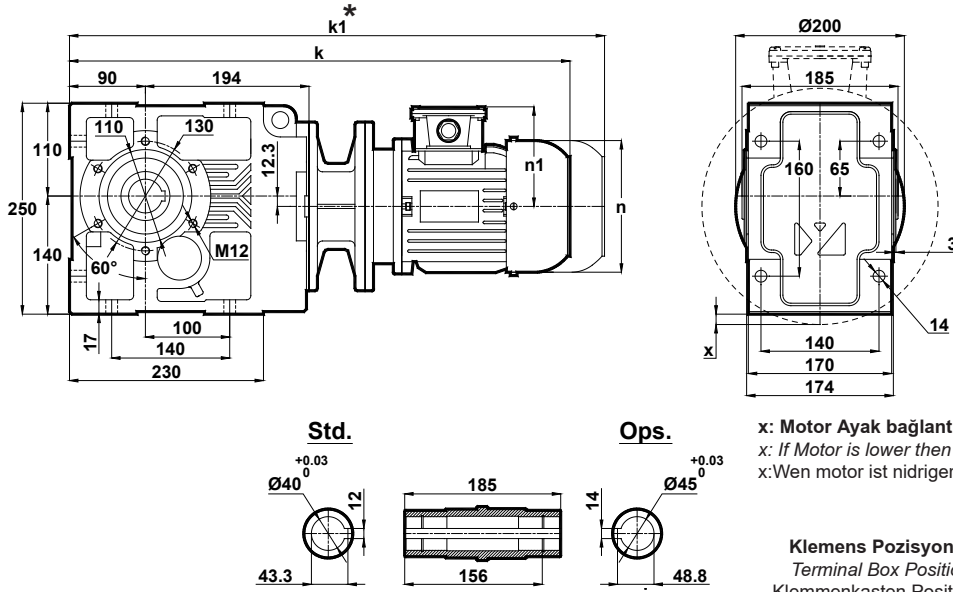

x: Motor ayak bağlantı yüzeyinin altında ise  
x: If Motor is lower then foot mounting plane  
x:Wen motor ist nidriger den die Anschlußplatte

**Klemens Pozisyonları**  
Terminal Box Positions  
Klemmenkasten Positionen

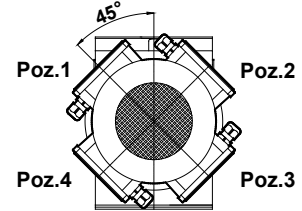

71-80-90-100-112-132  
Tip / Type / Typ

	71/B5	80/B5	90S/B5	90L/B5	100L/B5	112M/B5	132S/B5	132M/B5
k	570	590	610	635	684	704	768	806
k1	690	710	735	760	819	839	913	951
n	138	156	176	176	194	218	258	258
n1	110	118	126	126	135	146	168	168
x	-	-	-	-	-	-	1.3	1.3

## KV373.01

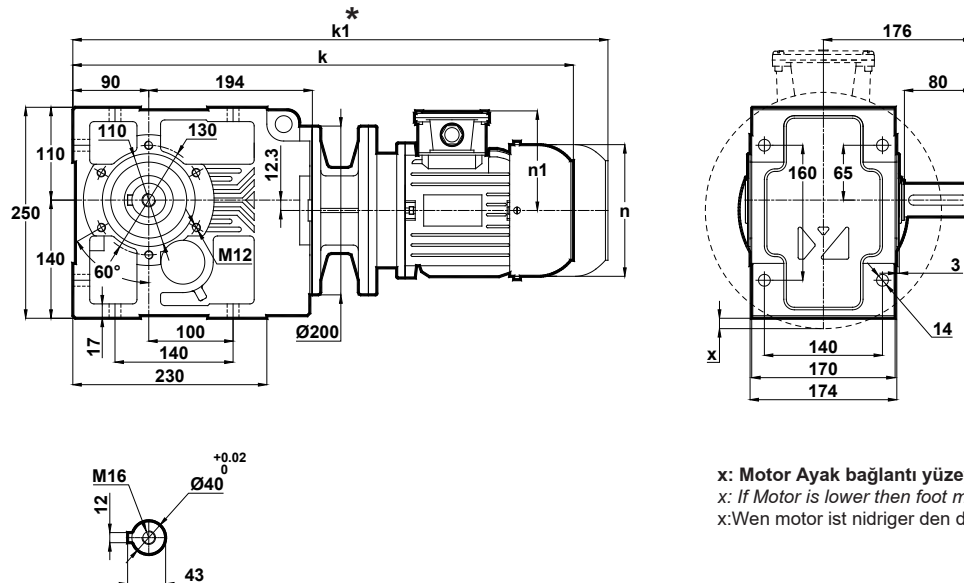

x: Motor ayak bağlantı yüzeyinin altında ise  
x: If Motor is lower then foot mounting plane  
x:Wen motor ist nidriger den die Anschlußplatte

	71/B5	80/B5	90S/B5	90L/B5	100L/B5	112M/B5	132S/B5	132M/B5
k	570	590	610	635	684	704	768	806
k1	690	710	735	760	819	839	913	951
n	138	156	176	176	194	218	258	258
n1	110	118	126	126	135	146	168	168
x	-	-	-	-	-	-	1.3	1.3

\* " k1 " Ölçüsü frenli redüktörlere aittir.  
Dimension " k1 " is for motors with brake.  
Maße " k1 " ist für Bremsmotoren.

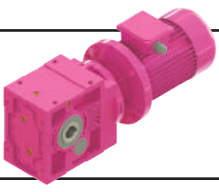

# Ölçü Sayfaları Dimension Pages Abmessungsseiten

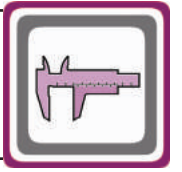

-Mil ucu çektirme deliği DIN 332 sayfa 2 / Tapped center hole to DIN 332, sheet 2 / Zentrierung mit gewinde DIN 332, Blatt 2

KV373.02  
KV373.02

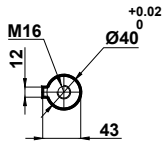
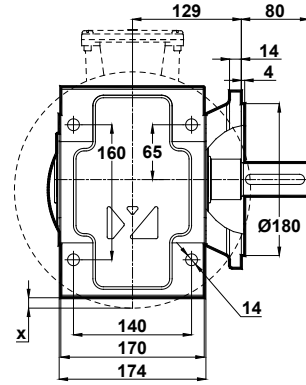
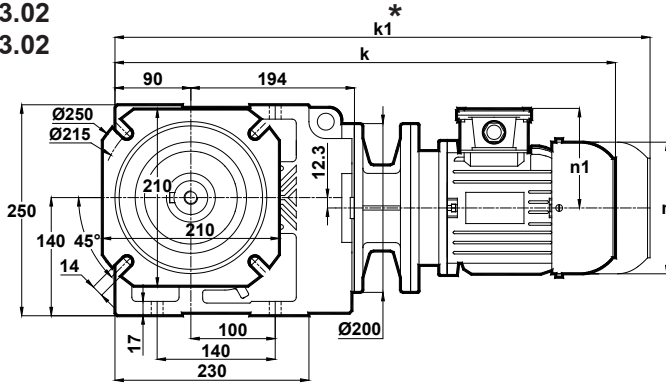

x: Motor Ayak bağlantı yüzeyinin altında ise  
x: If Motor is lower then foot mounting plane  
x:Wen motor ist nidriger den die Anschlußplatte

Klemens Pozisyonları  
Terminal Box Positions  
Klemmenkasten Positionen

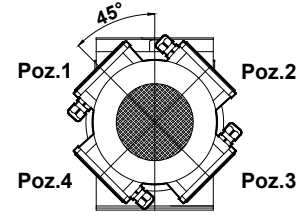

71-80-90-100-112-132  
Tip / Type / Typ

	71/B5	80/B5	90S/B5	90L/B5	100L/B5	112M/B5	132S/B5	132M/B5
k	570	590	610	635	684	704	768	806
k1	690	710	735	760	819	839	913	951
n	138	156	176	176	194	218	258	258
n1	110	118	126	126	135	146	168	168
x	-	-	-	-	-	-	1.3	1.3

KV373.03

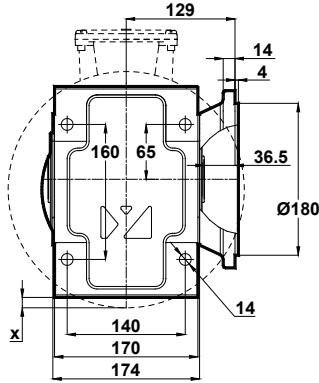
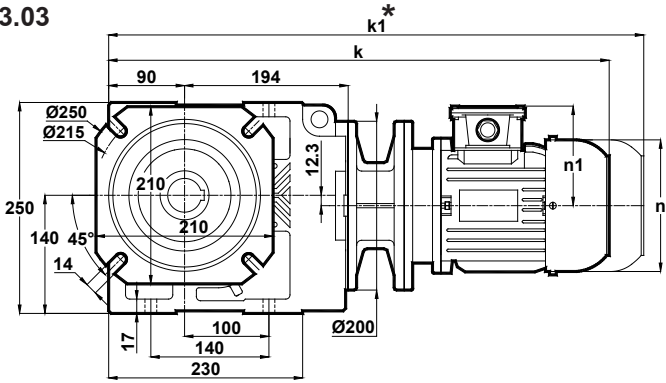

Std.

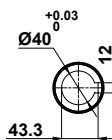

Ops.

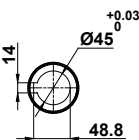
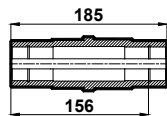

x: Motor Ayak bağlantı yüzeyinin altında ise  
x: If Motor is lower then foot mounting plane  
x:Wen motor ist nidriger den die Anschlußplatte

	71/B5	80/B5	90S/B5	90L/B5	100L/B5	112M/B5	132S/B5	132M/B5
k	570	590	610	635	684	704	768	806
k1	690	710	735	760	819	839	913	951
n	138	156	176	176	194	218	258	258
n1	110	118	126	126	135	146	168	168
x	-	-	-	-	-	-	1.3	1.3

\* " k1 " Ölçüsü frenli redüktörlere aittir.  
Dimension " k1 " is for motors with brake.  
Maße " k1 " ist für Bremsenmotoren.

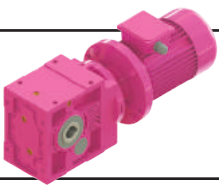

# Ölçü Sayfaları Dimension Pages Abmessungsseiten



-Mil ucu çekirme deliği DIN 332 sayfa 2 / Tapped center hole to DIN 332, sheet 2 / Zentrierung mit gewinde DIN 332, Blatt 2

KV373.04  
KV373.04

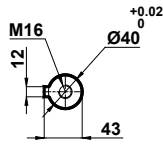
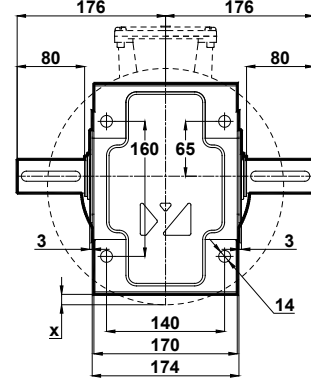
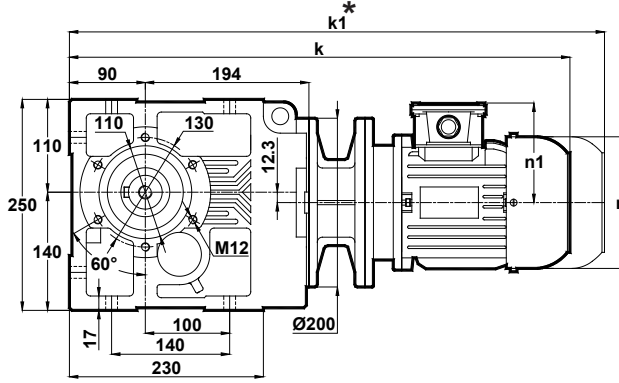

x: Motor Ayak bağlantı yüzeyinin altında ise  
x: If Motor is lower then foot mounting plane  
x: Wenn motor ist niedriger den die Anschlußplatte

Klemens Pozisyonları  
Terminal Box Positions  
Klemmenkasten Positionen

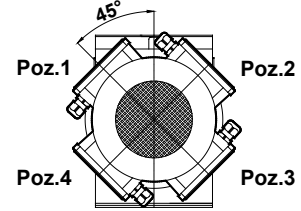

71-80-90-100-112-132  
Tip / Type / Typ

	71/B5	80/B5	90S/B5	90L/B5	100L/B5	112M/B5	132S/B5	132M/B5
k	570	590	610	635	684	704	768	806
k1	690	710	735	760	819	839	913	951
n	138	156	176	176	194	218	258	258
n1	110	118	126	126	135	146	168	168
x	-	-	-	-	-	-	1.3	1.3

KV373.05  
KV373.05

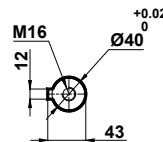
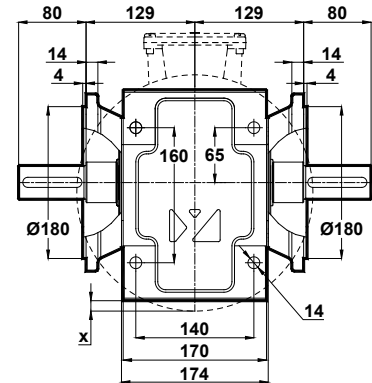
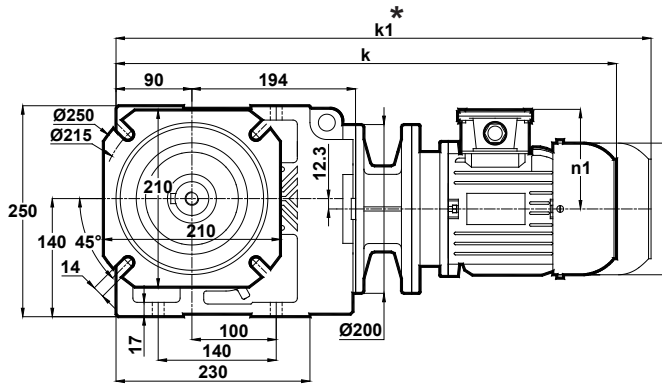

x: Motor Ayak bağlantı yüzeyinin altında ise  
x: If Motor is lower then foot mounting plane  
x: Wenn motor ist niedriger den die Anschlußplatte

	71/B5	80/B5	90S/B5	90L/B5	100L/B5	112M/B5	132S/B5	132M/B5
k	570	590	610	635	684	704	768	806
k1	690	710	735	760	819	839	913	951
n	138	156	176	176	194	218	258	258
n1	110	118	126	126	135	146	168	168
x	-	-	-	-	-	-	1.3	1.3

\* " k1 " Ölçüsü frenli redüktörlere aittir.  
Dimension " k1 " is for motors with brake.  
Maße " k1 " ist für Bremsenmotoren.

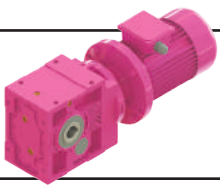

# Ölçü Sayfaları Dimension Pages Abmessungsseiten

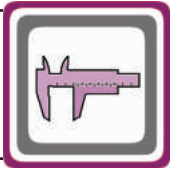

-Mil ucu çekirme deliği DIN 332 sayfa 2 / Tapped center hole to DIN 332, sheet 2 / Zentrierung mit gewinde DIN 332, Blatt 2

KV373.08  
KV373.08

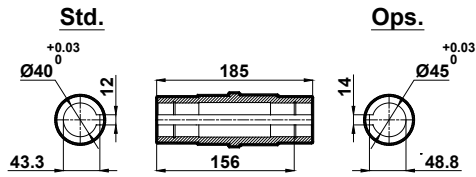
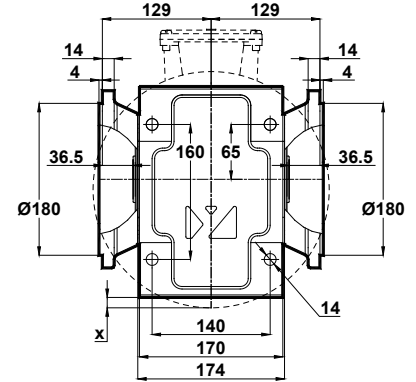
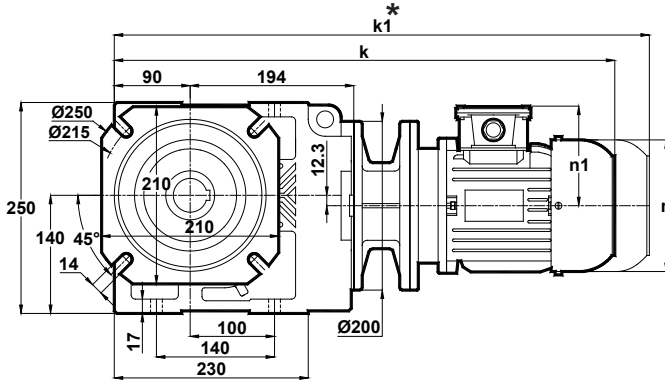

x: Motor ayak bağlantı yüzeyinin altında ise  
x: If Motor is lower then foot mounting plane  
x: Wenn motor ist niedriger den die Anschlußplatte

Klemens Pozisyonları  
Terminal Box Positions  
Klemmenkasten Positionen

	71/B5	80/B5	90S/B5	90L/B5	100L/B5	112M/B5	132S/B5	132M/B5
k	570	590	610	635	684	704	768	806
k1	690	710	735	760	819	839	913	951
n	138	156	176	176	194	218	258	258
n1	110	118	126	126	135	146	168	168
x	-	-	-	-	-	-	1.3	1.3

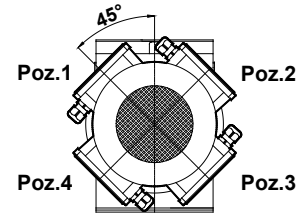

71-80-90-100-112-132  
Tip / Type / Typ

\* " k1 " Ölçüsü frenli redüktörlere aittir.  
Dimension " k1 " is for motors with brake.  
Maße " k1 " ist für Bremsenmotoren.

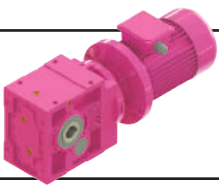

# Ölçü Sayfaları

## Dimension Pages

### Abmessungsseiten



-Mil ucu çekirme deliği DIN 332 sayfa 2 / Tapped center hole to DIN 332, sheet 2 / Zentrierung mit gewinde DIN 332, Blatt 2

#### KV374.00

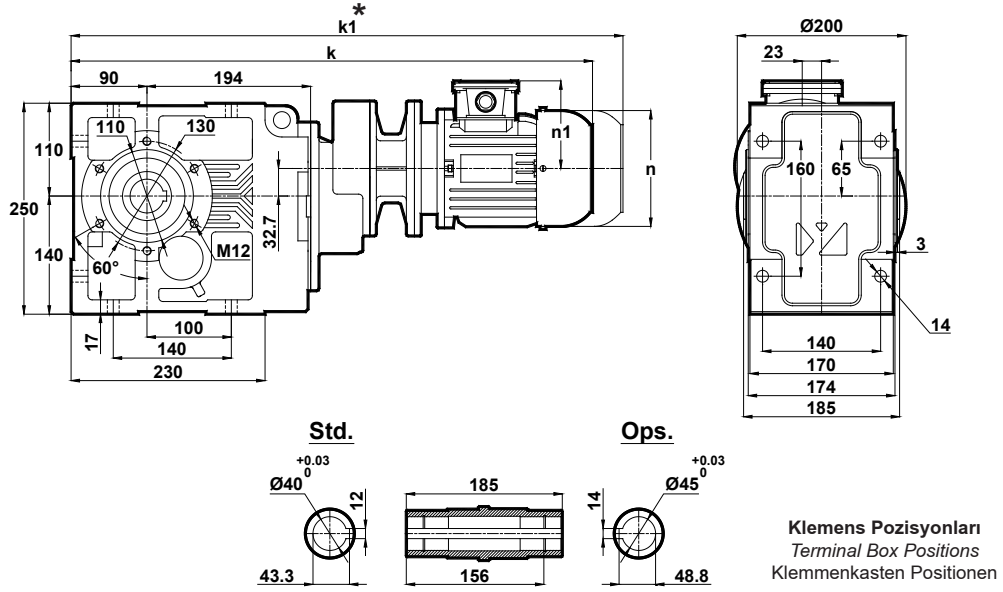

	63/B5	71/B5	80/B5
k	621	618	667
k1	-	738	787
n	116	138	156
n1	97	110	118

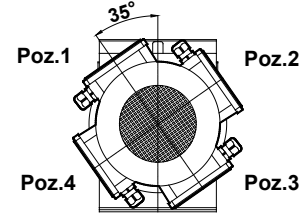

63-71-80  
Tip / Type / Typ

#### KV374.01

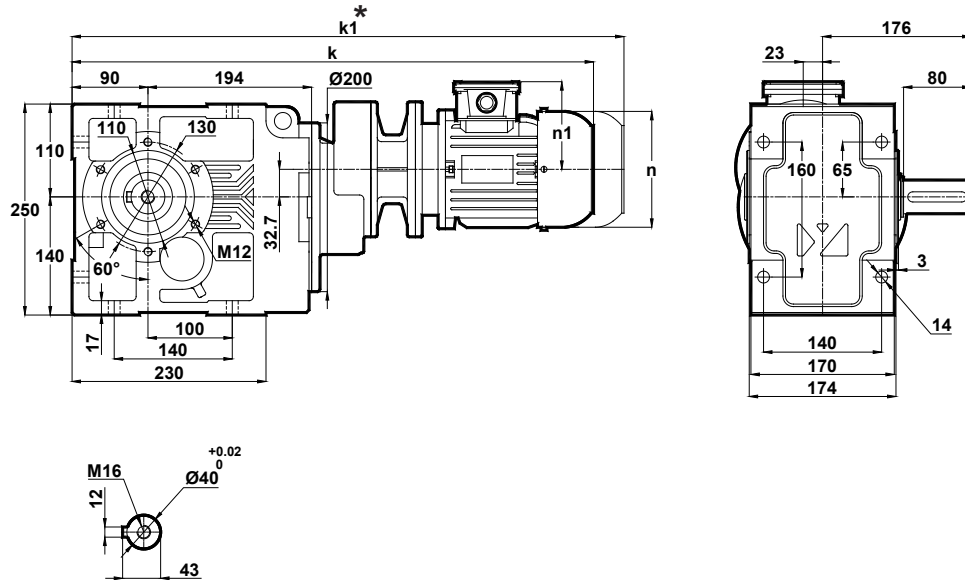

	63/B5	71/B5	80/B5
k	621	618	667
k1	-	738	787
n	116	138	156
n1	97	110	118

\* "k1" Ölçüsü frenli redüktörlere aittir.  
Dimension "k1" is for motors with brake.  
Maße "k1" ist für Bremsenmotoren.

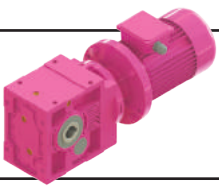

# Ölçü Sayfaları Dimension Pages Abmessungenseiten

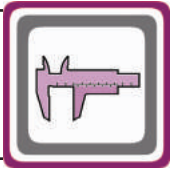

-Mil ucu çekirme deliği DIN 332 sayfa 2 / Tapped center hole to DIN 332, sheet 2 / Zentrierung mit gewinde DIN 332, Blatt 2

## KV374.02

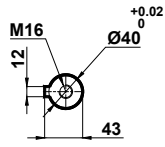
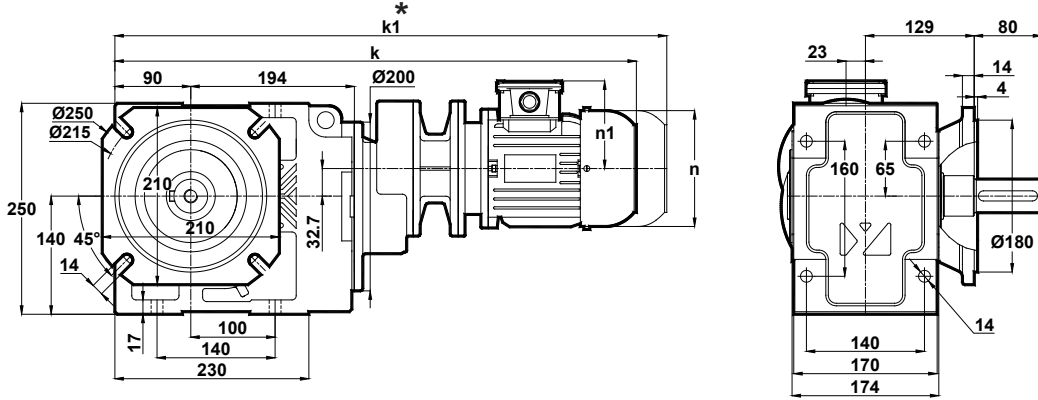

	63/B5	71/B5	80/B5
k	621	618	667
k1	-	738	787
n	116	138	156
n1	97	110	118

Klemens Pozisyonları  
Terminal Box Positions  
Klemmenkasten Positionen

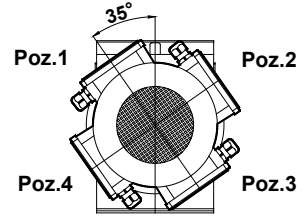

63-71-80  
Tip / Type / Typ

## KV374.03

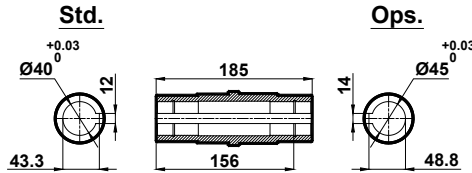
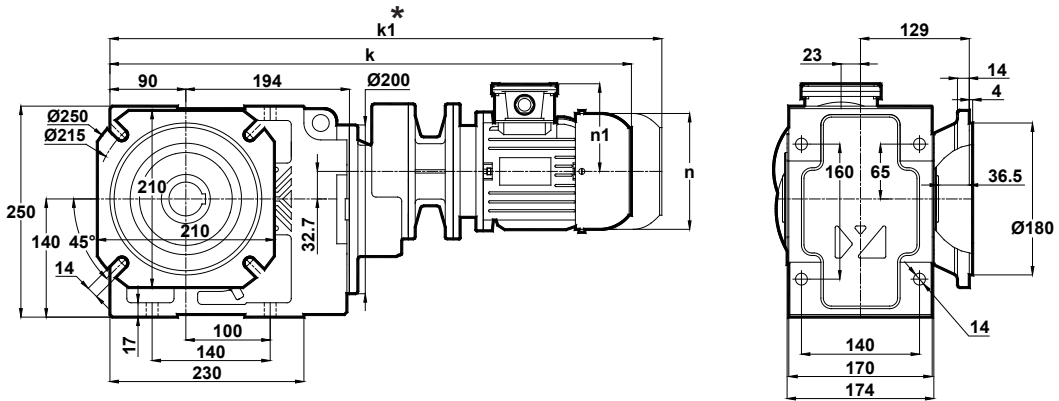

	63/B5	71/B5	80/B5
k	621	618	667
k1	-	738	787
n	116	138	156
n1	97	110	118

\* "k1" Ölçüsü frenli redüktörlere aittir.  
Dimension "k1" is for motors with brake.  
Maße "k1" ist für Bremsenmotoren.

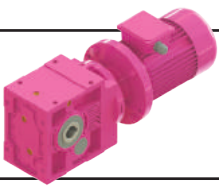

# Ölçü Sayfaları

## Dimension Pages

### Abmessungsseiten



-Mil ucu çektirme deliği DIN 332 sayfa 2 / Tapped center hole to DIN 332, sheet 2 / Zentrierung mit gewinde DIN 332, Blatt 2

#### KV374.04

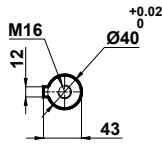
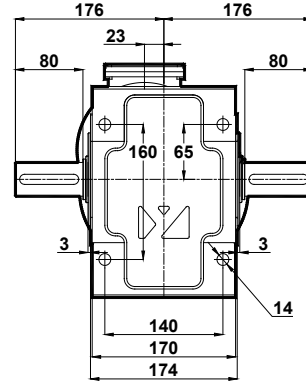
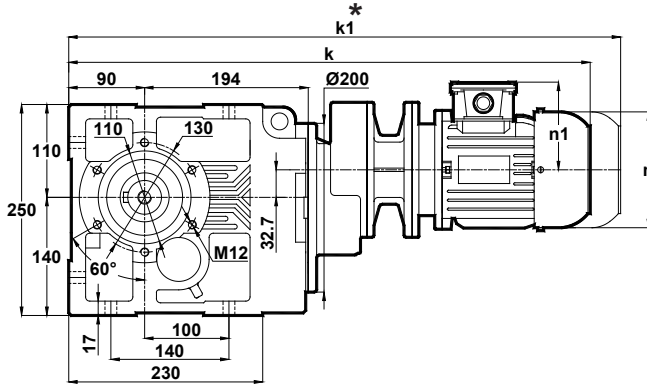

	63/B5	71/B5	80/B5
k	621	618	667
k1	-	738	787
n	116	138	156
n1	97	110	118

Klemens Pozisyonları  
Terminal Box Positions  
Klemmenkasten Positionen

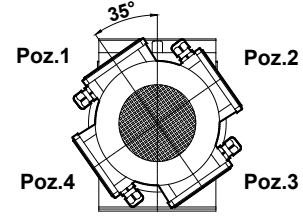

63-71-80  
Tip / Type / Typ

#### KV374.05

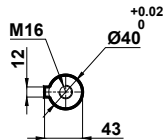
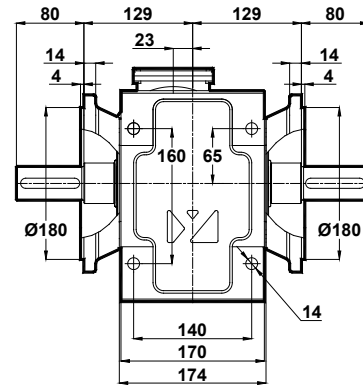
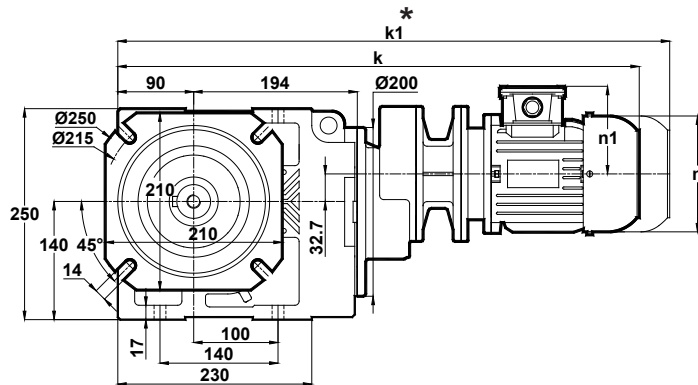

	63/B5	71/B5	80/B5
k	621	618	667
k1	-	738	787
n	116	138	156
n1	97	110	118

\* "k1" Ölçüsü frenli redüktörlere aittir.  
Dimension "k1" is for motors with brake.  
Maße "k1" ist für Bremsenmotoren.

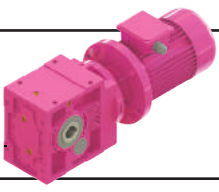

# Ölçü Sayfaları Dimension Pages Abmessungsseiten

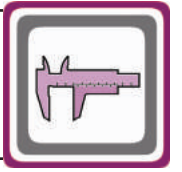

-Mil ucu çekirme deliği DIN 332 sayfa 2 / Tapped center hole to DIN 332, sheet 2 / Zentrierung mit gewinde DIN 332, Blatt 2

KV374.08

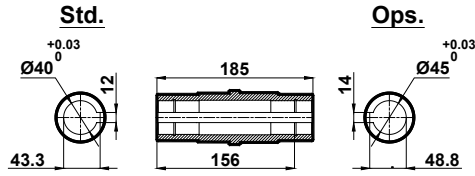
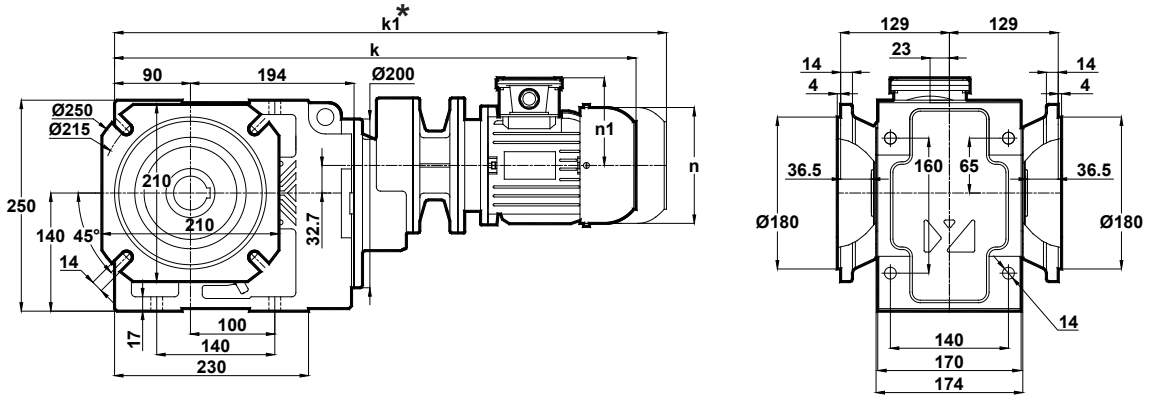

**Klemens Pozisyonları**  
Terminal Box Positions  
Klemmenkasten Positionen

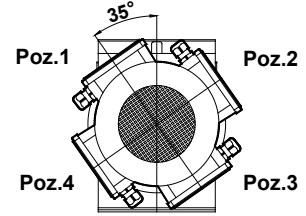

63-71-80  
Tip / Type / Typ

	63/B5	71/B5	80/B5
k	621	618	667
k1	-	738	787
n	116	138	156
n1	97	110	118

\* " k1 " Ölçüsü frenli redüktörlere aittir.  
Dimension " k1 " is for motors with brake.  
Maße " k1 " ist für Bremsenmotoren.

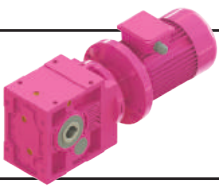

# Ölçü Sayfaları Dimension Pages Abmessungsseiten



-Mil ucu çektirme deliği DIN 332 sayfa 2 / Tapped center hole to DIN 332, sheet 2 / Zentrierung mit gewinde DIN 332, Blatt 2

KV375.00  
KV376.00

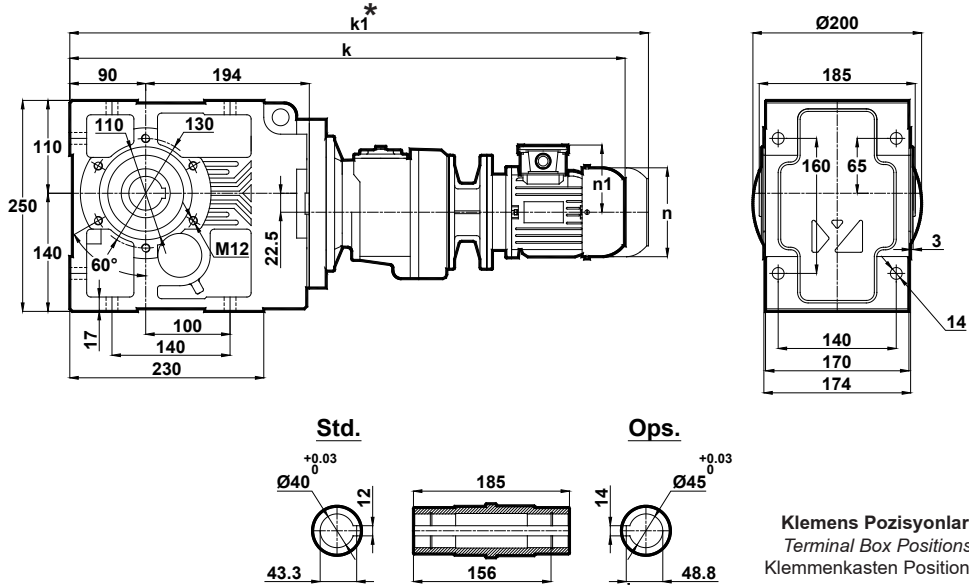

KV375.01  
KV376.01

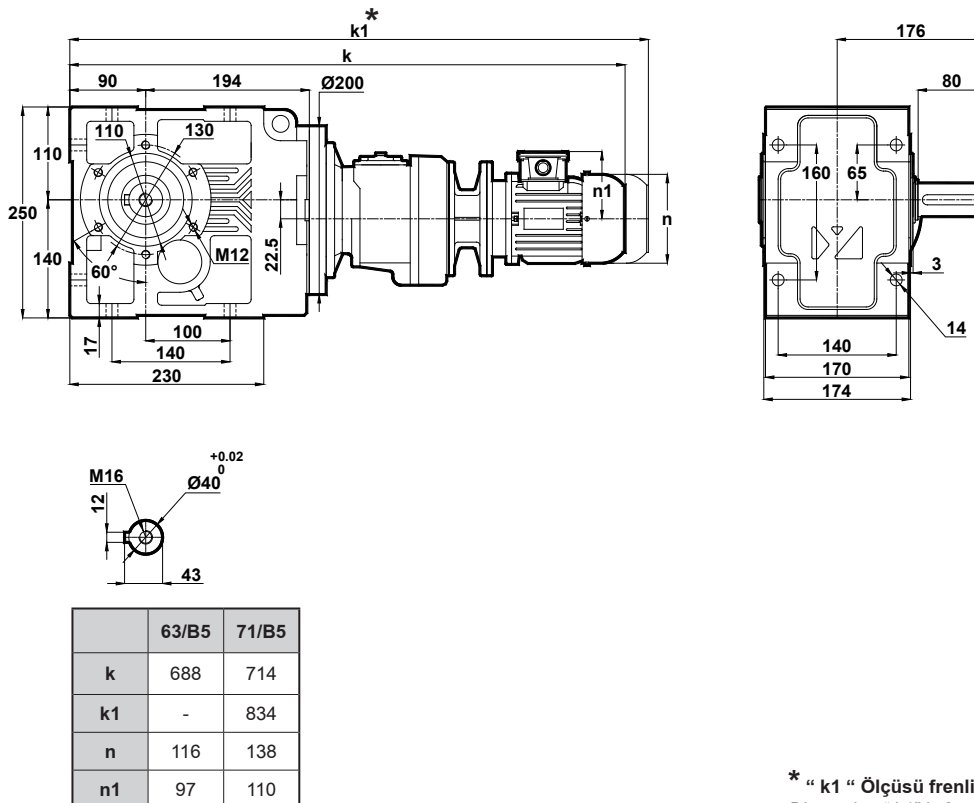

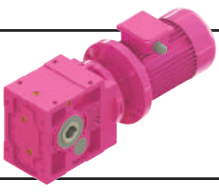

# Ölçü Sayfaları Dimension Pages Abmessungsseiten

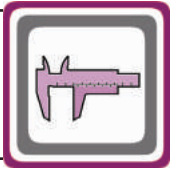

-Mil ucu çektirme deliği DIN 332 sayfa 2 / Tapped center hole to DIN 332, sheet 2 / Zentrierung mit gewinde DIN 332, Blatt 2

KV375.02  
KV376.02

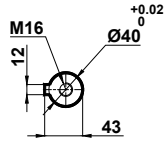
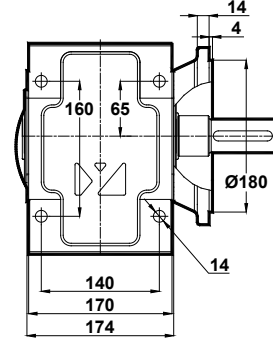
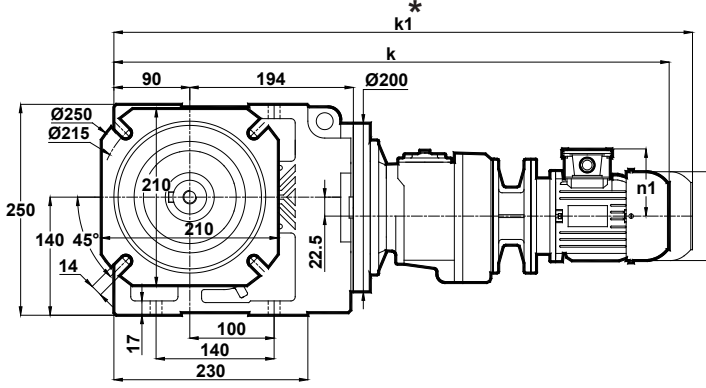

Klemens Pozisyonları  
Terminal Box Positions  
Klemmenkasten Positionen

	63/B5	71/B5
k	688	714
k1	-	834
n	116	138
n1	97	110

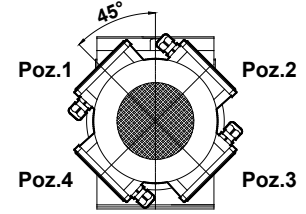

63-71  
Tip / Type / Typ

KV375.03  
KV376.03

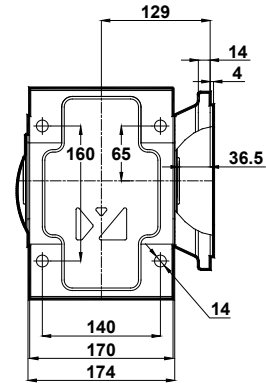
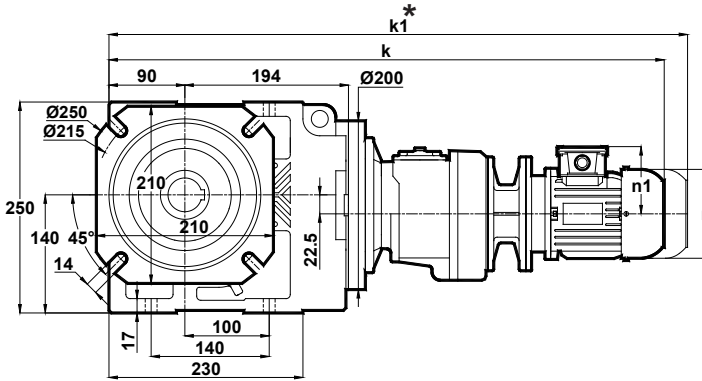

Std.

Ops.

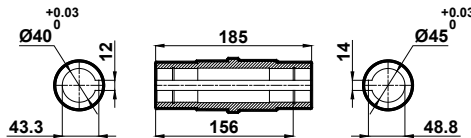

	63/B5	71/B5
k	688	714
k1	-	834
n	116	138
n1	97	110

\* " k1 " Ölçüsü frenli redüktörlere aittir.  
Dimension " k1 " is for motors with brake.  
Maße " k1 " ist für Bremsenmotoren.

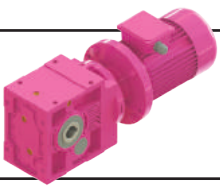

# Ölçü Sayfaları Dimension Pages Abmessungsseiten



-Mil ucu çekirme deliği DIN 332 sayfa 2 / Tapped center hole to DIN 332, sheet 2 / Zentrierung mit gewinde DIN 332, Blatt 2

KV375.04  
KV376.04

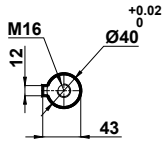
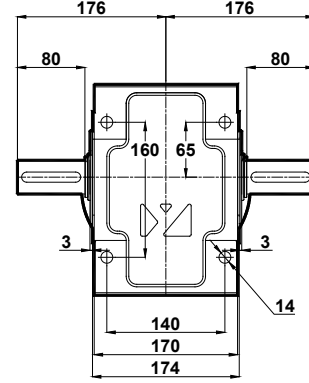
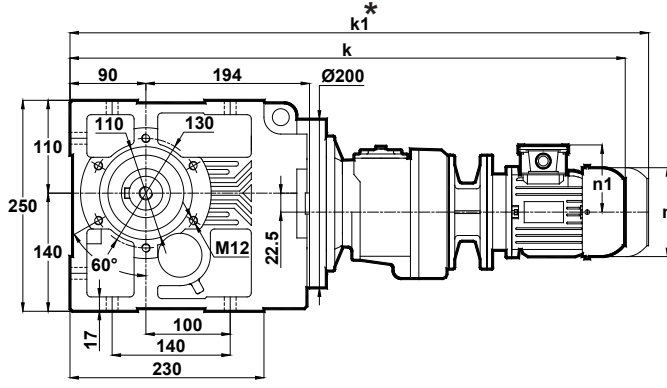

	63/B5	71/B5
k	688	714
k1	-	834
n	116	138
n1	97	110

Klemens Pozisyonları  
Terminal Box Positions  
Klemmenkasten Positionen

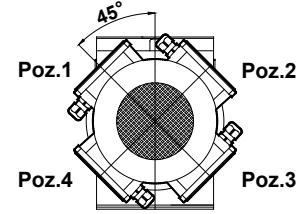

63-71  
Tip / Type / Typ

KV375.05  
KV376.05

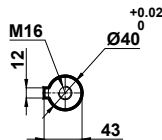
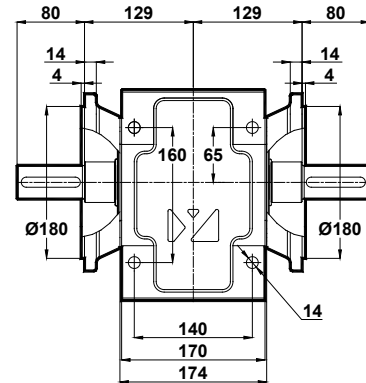
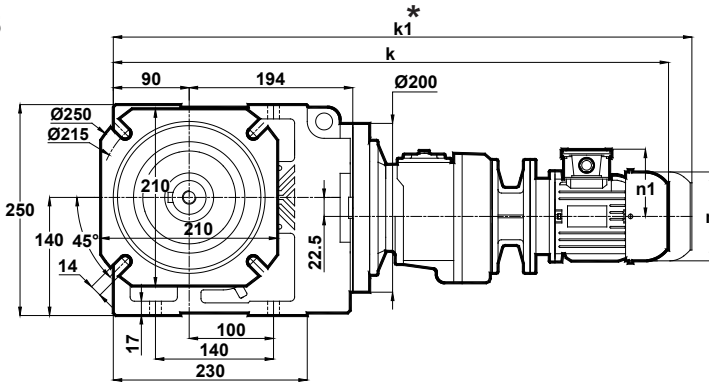

	63/B5	71/B5
k	688	714
k1	-	834
n	116	138
n1	97	110

\* " k1 " Ölçüsü frenli redüktörlere aittir.  
Dimension " k1 " is for motors with brake.  
Maße " k1 " ist für Bremsmotoren.

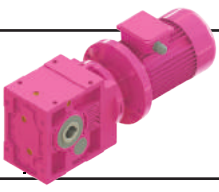

# Ölçü Sayfaları Dimension Pages Abmessungsseiten

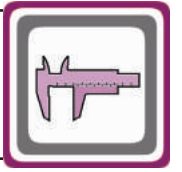

-Mil ucu çekirme deliği DIN 332 sayfa 2 / Tapped center hole to DIN 332, sheet 2 / Zentrierung mit gewinde DIN 332, Blatt 2

KV375.08  
KV376.08

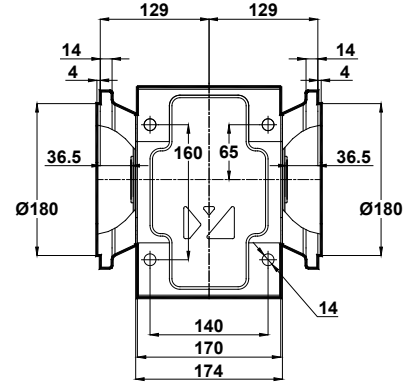
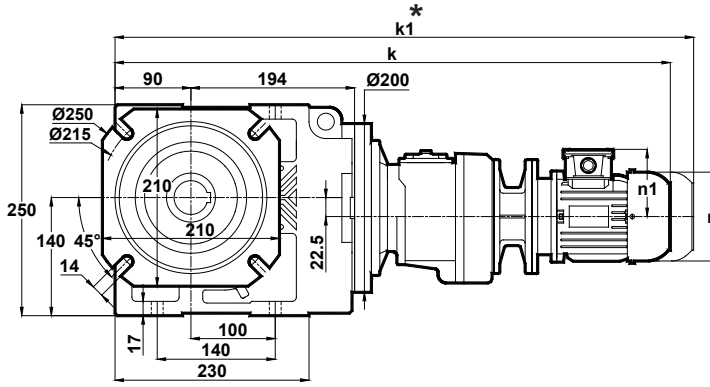

Std.

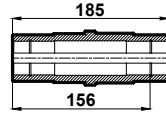
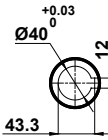

Ops.

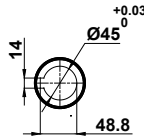

	63/B5	71/B5
k	688	714
k1	-	834
n	116	138
n1	97	110

Klemens Pozisyonları  
Terminal Box Positions  
Klemmenkasten Positionen

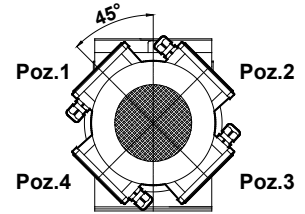

63-71  
Tip / Type / Typ

\* " k1 " Ölçüsü frenli redüktörlere aittir.  
Dimension " k1 " is for motors with brake.  
Maße " k1 " ist für Bremsenmotoren.

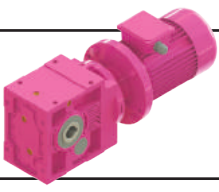

# Ölçü Sayfaları Dimension Pages Abmessungsseiten



-Mil ucu çektirme deliği DIN 332 sayfa 2 / Tapped center hole to DIN 332, sheet 2 / Zentrierung mit gewinde DIN 332, Blatt 2

## KV473.00

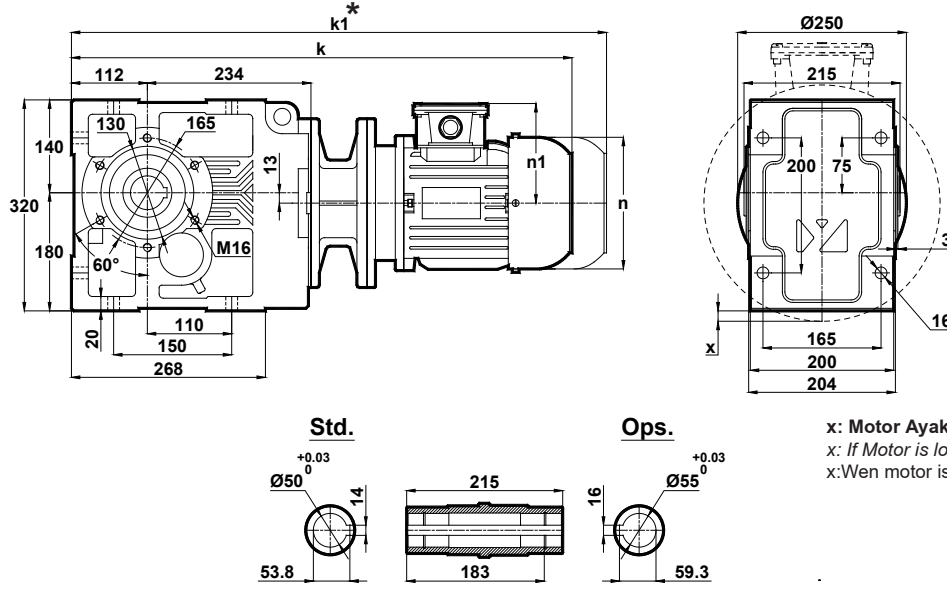

x: Motor Ayak bağlantı yüzeyinin altında ise  
x: If Motor is lower then foot mounting plane  
x:Wen motor ist nidriger den die Anschlußplatte

Klemens Pozisyonları  
Terminal Box Positions  
Klemmenkasten Positionen

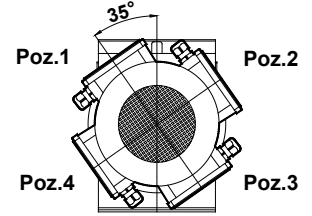

80-90-100-112-132-160-180  
Tip / Type / Typ

	80/B5	90S/B5	90L/B5	100L/B5	112M/B5	132S/B5	132M/B5	160M/B5	160L/B5	180M/B5	180L/B5
k	642	662	687	737	757	820	858	1009	1053	1066	1104
k1	762	787	812	872	892	965	1003	1179	1223	1236	1274
n	156	176	176	194	218	258	258	310	310	348	348
n1	118	126	126	135	146	168	168	225	225	241	241
x	-	-	-	-	-	-	-	-	-	7	7

## KV473.01

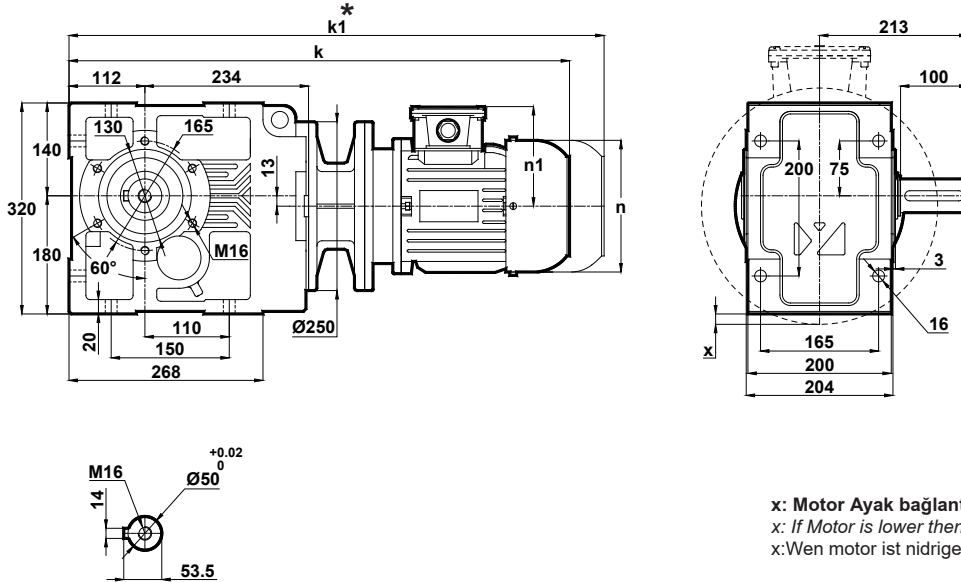

x: Motor Ayak bağlantı yüzeyinin altında ise  
x: If Motor is lower then foot mounting plane  
x:Wen motor ist nidriger den die Anschlußplatte

	80/B5	90S/B5	90L/B5	100L/B5	112M/B5	132S/B5	132M/B5	160M/B5	160L/B5	180M/B5	180L/B5
k	642	662	687	737	757	820	858	1009	1053	1066	1104
k1	762	787	812	872	892	965	1003	1179	1223	1236	1274
n	156	176	176	194	218	258	258	310	310	348	348
n1	118	126	126	135	146	168	168	225	225	241	241
x	-	-	-	-	-	-	-	-	-	7	7

\* " k1 " Ölçüsü frenli redüktörlere aittir.  
Dimension " k1 " is for motors with brake.  
Maße " k1 " ist für Bremsenmotoren.

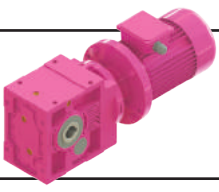

# Ölçü Sayfaları Dimension Pages Abmessungsseiten

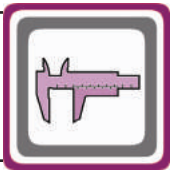

-Mil ucu çektirme deliği DIN 332 sayfa 2 / Tapped center hole to DIN 332, sheet 2 / Zentrierung mit gewinde DIN 332, Blatt 2

## KV473.02

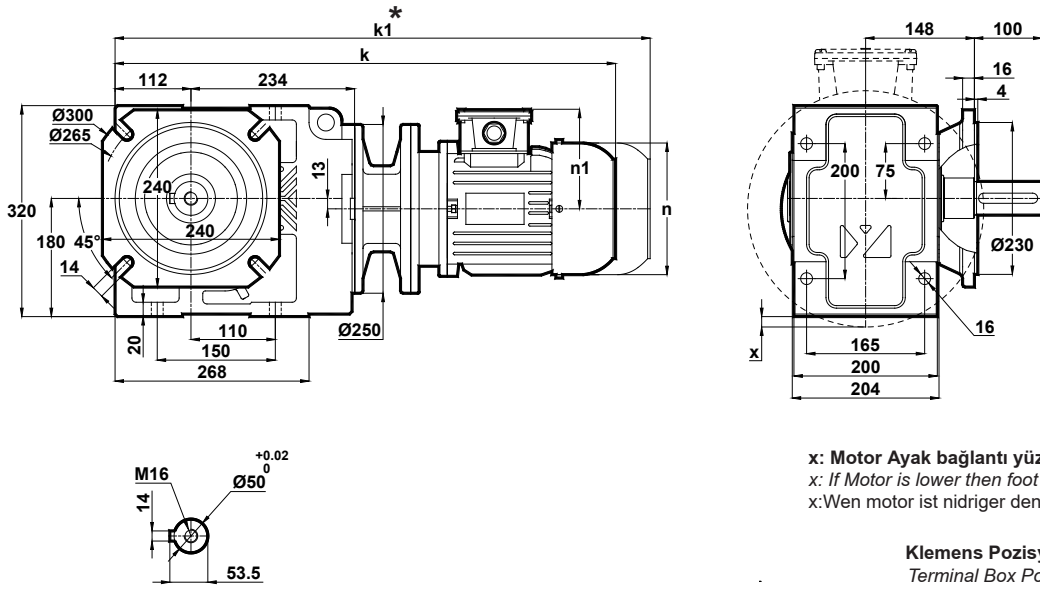

x: Motor Ayak bağlantı yüzeyinin altında ise  
x: If Motor is lower then foot mounting plane  
x: Wenn motor ist niedriger den die Anschlußplatte

Klemens Pozisyonları  
Terminal Box Positions  
Klemmenkasten Positionen

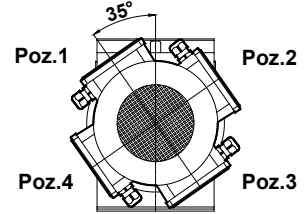

80-90-100-112-132-160-180  
Tip / Type / Typ

	80/B5	90S/B5	90L/B5	100L/B5	112M/B5	132S/B5	132M/B5	160M/B5	160L/B5	180M/B5	180L/B5
k	642	662	687	737	757	820	858	1009	1053	1066	1104
k1	762	787	812	872	892	965	1003	1179	1223	1236	1274
n	156	176	176	194	218	258	258	310	310	348	348
n1	118	126	126	135	146	168	168	225	225	241	241
x	-	-	-	-	-	-	-	-	-	7	7

## KV473.03

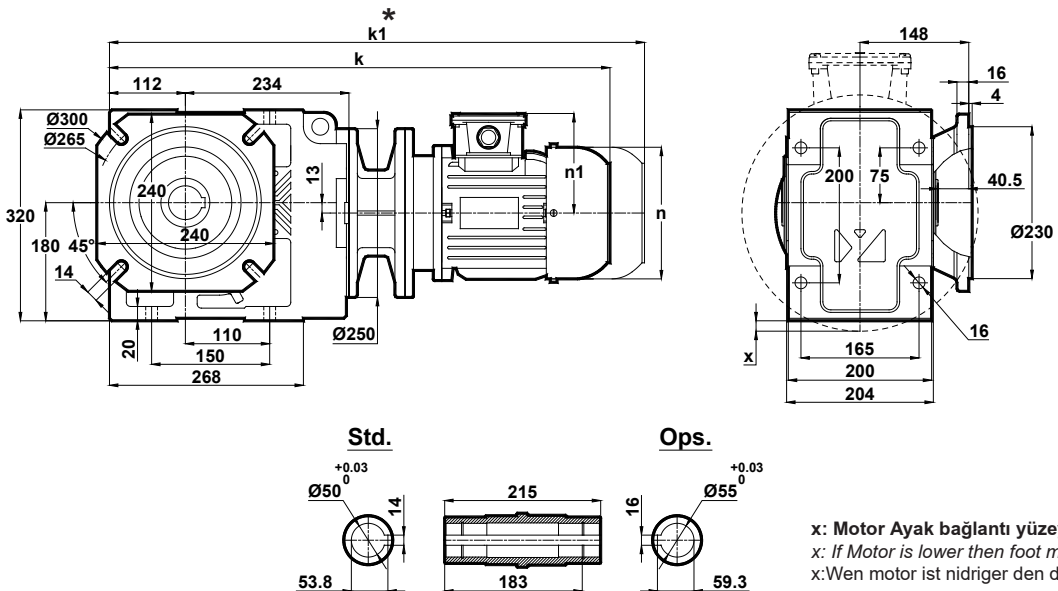

x: Motor Ayak bağlantı yüzeyinin altında ise  
x: If Motor is lower then foot mounting plane  
x: Wenn motor ist niedriger den die Anschlußplatte

\* " k1 " Ölçüsü frenli redüktörlere aittir.  
Dimension " k1 " is for motors with brake.  
Maße " k1 " ist für Bremsenmotoren.

	80/B5	90S/B5	90L/B5	100L/B5	112M/B5	132S/B5	132M/B5	160M/B5	160L/B5	180M/B5	180L/B5
k	642	662	687	737	757	820	858	1009	1053	1066	1104
k1	762	787	812	872	892	965	1003	1179	1223	1236	1274
n	156	176	176	194	218	258	258	310	310	348	348
n1	118	126	126	135	146	168	168	225	225	241	241
x	-	-	-	-	-	-	-	-	-	7	7

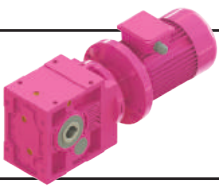

# Ölçü Sayfaları Dimension Pages Abmessungsseiten



-Mil ucu çektirme deliği DIN 332 sayfa 2 / Tapped center hole to DIN 332, sheet 2 / Zentrierung mit gewinde DIN 332, Blatt 2

## KV473.04

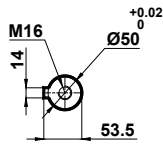
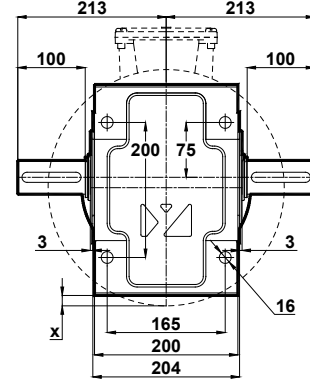
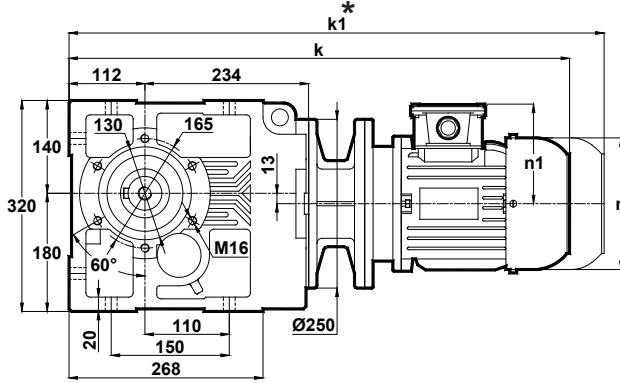

x: Motor Ayak bağlantı yüzeyinin altında ise  
x: If Motor is lower then foot mounting plane  
x:Wen motor ist nidriger den die Anschlußplatte

Klemens Pozisyonları  
Terminal Box Positions  
Klemmenkasten Positionen

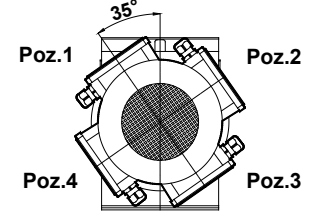

80-90-100-112-132-160-180  
Tip / Type / Typ

	80/B5	90S/B5	90L/B5	100L/B5	112M/B5	132S/B5	132M/B5	160M/B5	160L/B5	180M/B5	180L/B5
k	642	662	687	737	757	820	858	1009	1053	1066	1104
k1	762	787	812	872	892	965	1003	1179	1223	1236	1274
n	156	176	176	194	218	258	258	310	310	348	348
n1	118	126	126	135	146	168	168	225	225	241	241
x	-	-	-	-	-	-	-	-	-	7	7

## KV473.05

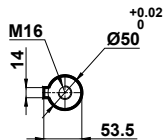
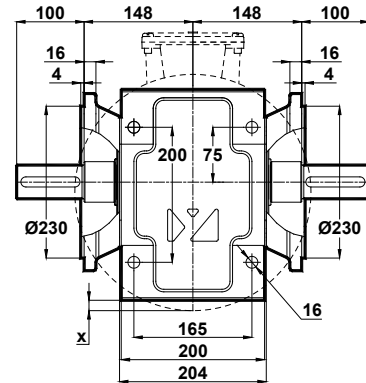
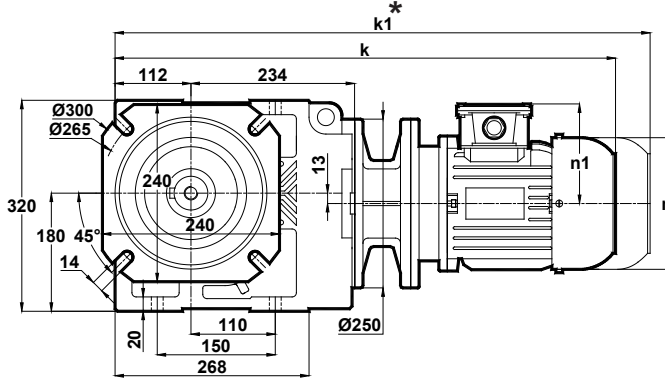

x: Motor Ayak bağlantı yüzeyinin altında ise  
x: If Motor is lower then foot mounting plane  
x:Wen motor ist nidriger den die Anschlußplatte

	80/B5	90S/B5	90L/B5	100L/B5	112M/B5	132S/B5	132M/B5	160M/B5	160L/B5	180M/B5	180L/B5
k	642	662	687	737	757	820	858	1009	1053	1066	1104
k1	762	787	812	872	892	965	1003	1179	1223	1236	1274
n	156	176	176	194	218	258	258	310	310	348	348
n1	118	126	126	135	146	168	168	225	225	241	241
x	-	-	-	-	-	-	-	-	-	7	7

\* " k1 " Ölçüsü frenli redüktörlere aittir.  
Dimension " k1 " is for motors with brake.  
Maße " k1 " ist für Bremsmotoren.

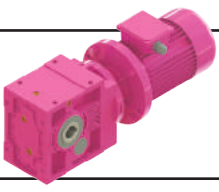

# Ölçü Sayfaları Dimension Pages Abmessungsseiten

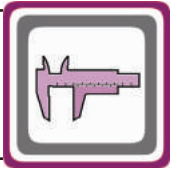

-Mil ucu çektirme deliği DIN 332 sayfa 2 / Tapped center hole to DIN 332, sheet 2 / Zentrierung mit gewinde DIN 332, Blatt 2

KV473.08

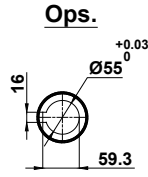
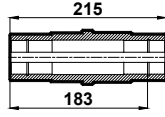
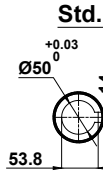
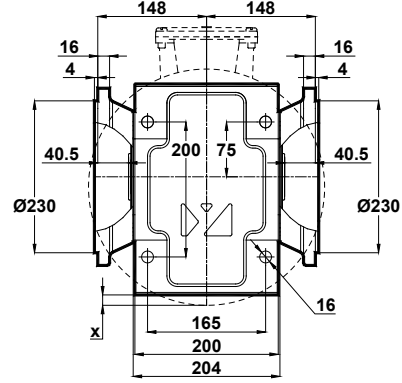
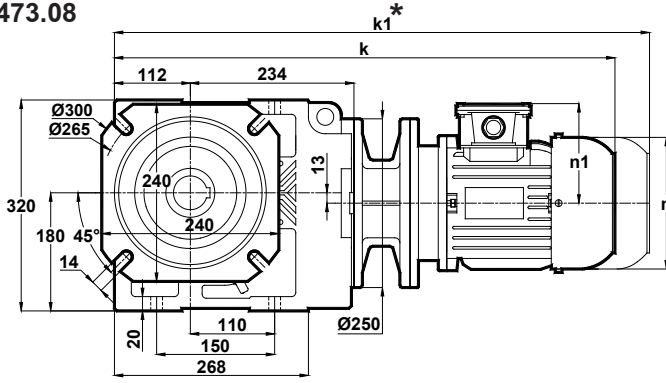

x: Motor Ayak bağlantı yüzeyinin altında ise  
x: If Motor is lower then foot mounting plane  
x: Wenn motor ist niedriger den die Anschlußplatte

**Klemens Pozisyonları**  
Terminal Box Positions  
Klemmenkasten Positionen

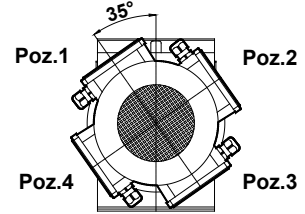

80-90-100-112-132-160-180  
Tip / Type / Typ

	80/B5	90S/B5	90L/B5	100L/B5	112M/B5	132S/B5	132M/B5	160M/B5	160L/B5	180M/B5	180L/B5
k	642	662	687	737	757	820	858	1009	1053	1066	1104
k1	762	787	812	872	892	965	1003	1179	1223	1236	1274
n	156	176	176	194	218	258	258	310	310	348	348
n1	118	126	126	135	146	168	168	225	225	241	241
x	-	-	-	-	-	-	-	-	-	7	7

\* " k1 " Ölçüsü frenli redüktörlere aittir.  
Dimension " k1 " is for motors with brake.  
Maße " k1 " ist für Bremsenmotoren.

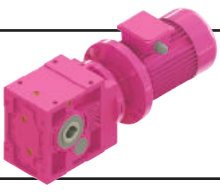

# Ölçü Sayfaları Dimension Pages Abmessungsseiten



-Mil ucu çekirme deliği DIN 332 sayfa 2 / Tapped center hole to DIN 332, sheet 2 / Zentrierung mit gewinde DIN 332, Blatt 2

## KV474.00

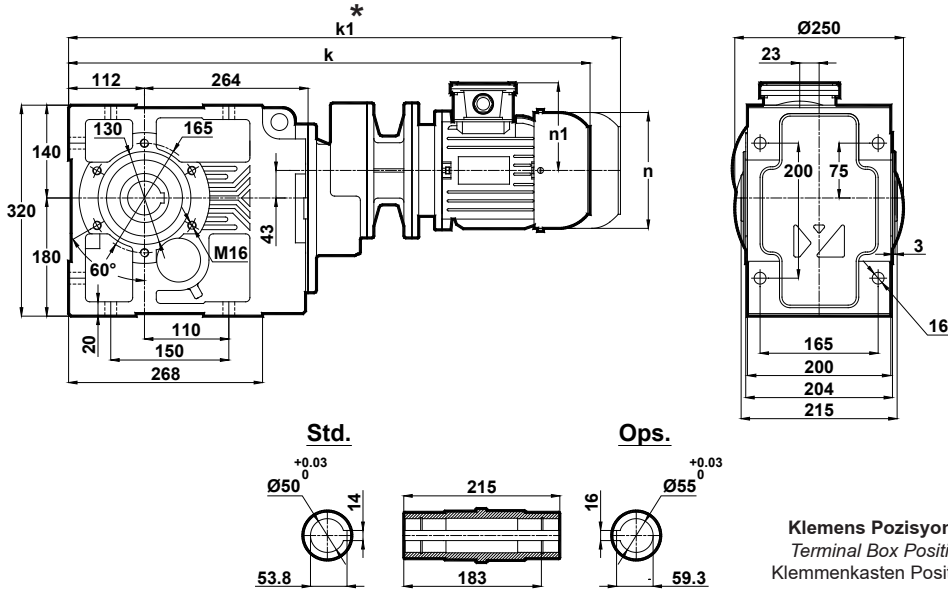

Klemens Pozisyonları  
Terminal Box Positions  
Klemmenkasten Positionen

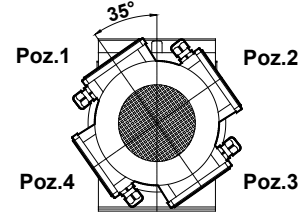

71-80  
Tip / Type / Typ

## KV474.01

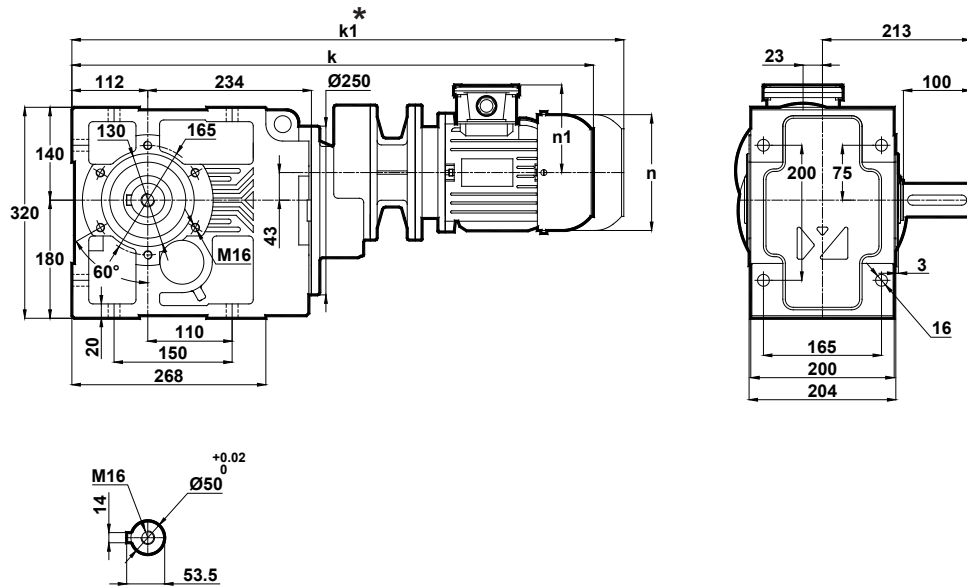

	71/B5	80/B5
k	720	740
k1	840	860
n	138	156
n1	110	118

\* " k1 " Ölçüsü frenli redüktörlere aittir.  
Dimension " k1 " is for motors with brake.  
Maße " k1 " ist für Bremsenmotoren.

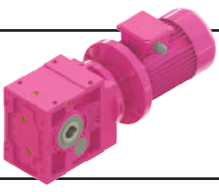

# Ölçü Sayfaları Dimension Pages Abmessungsseiten

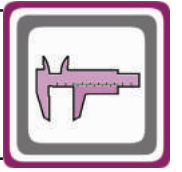

-Mil ucu çektirme deliği DIN 332 sayfa 2 / Tapped center hole to DIN 332, sheet 2 / Zentrierung mit gewinde DIN 332, Blatt 2

## KV474.02

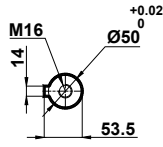
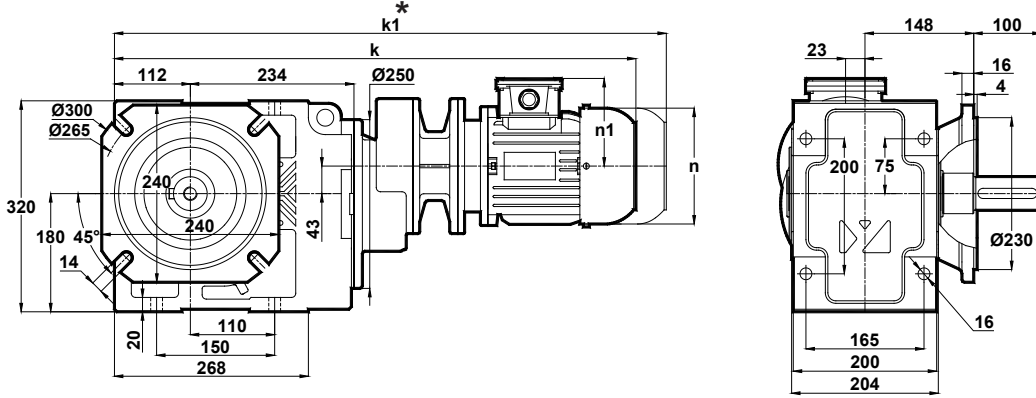

	71/B5	80/B5
k	720	740
k1	840	860
n	138	156
n1	110	118

Klemens Pozisyonları  
Terminal Box Positions  
Klemmenkasten Positionen

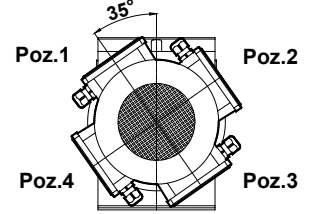

71-80  
Tip / Type / Typ

## KV474.03

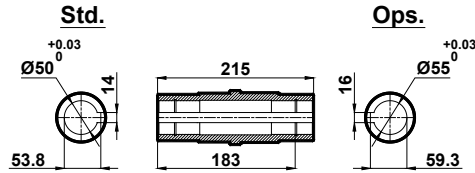
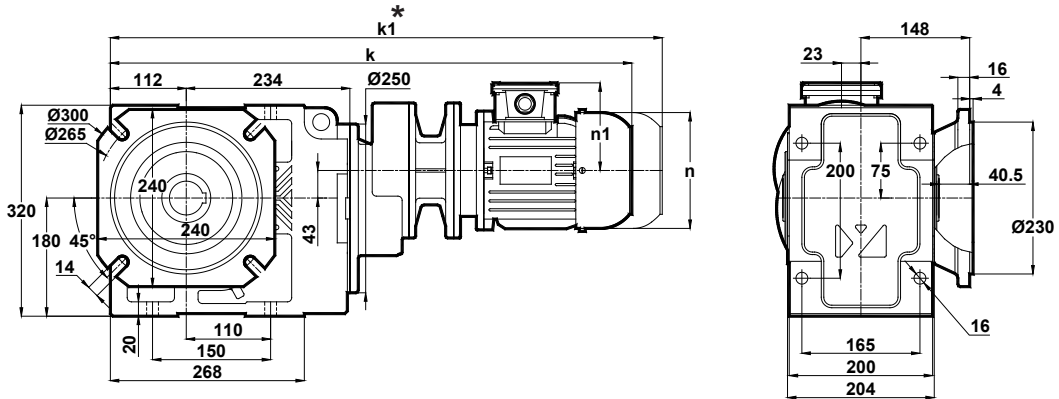

	71/B5	80/B5
k	720	740
k1	840	860
n	138	156
n1	110	118

\* " k1 " Ölçüsü frenli redüktörlere aittir.  
Dimension " k1 " is for motors with brake.  
Maße " k1 " ist für Bremsenmotoren.

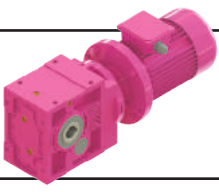

# Ölçü Sayfaları Dimension Pages Abmessungsseiten



-Mil ucu çekirme deliği DIN 332 sayfa 2 / Tapped center hole to DIN 332, sheet 2 / Zentrierung mit gewinde DIN 332, Blatt 2

## KV474.04

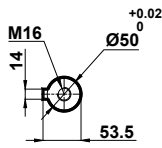
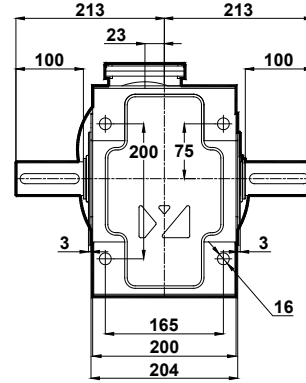
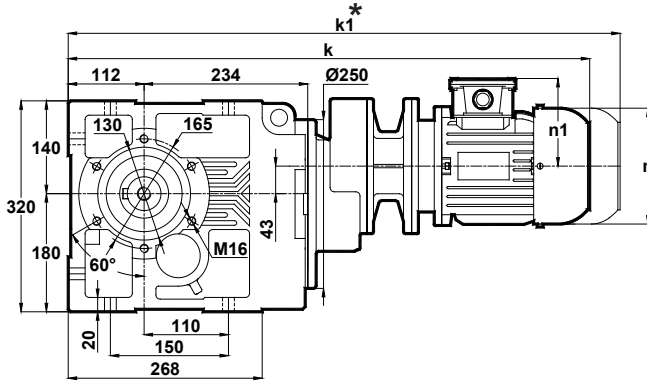

	71/B5	80/B5
k	720	740
k1	840	860
n	138	156
n1	110	118

Klemens Pozisyonları  
Terminal Box Positions  
Klemmenkasten Positionen

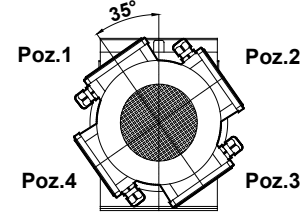

71-80  
Tip / Type / Typ

## KV474.05

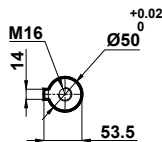
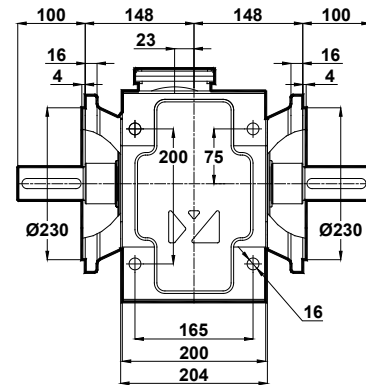
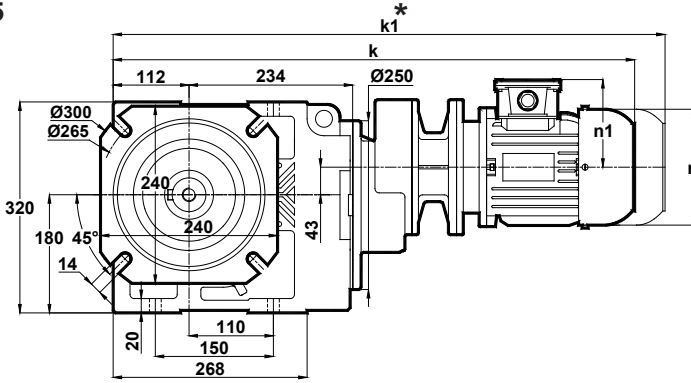

	71/B5	80/B5
k	720	740
k1	840	860
n	138	156
n1	110	118

\* "k1" Ölçüsü frenli redüktörlere aittir.  
Dimension "k1" is for motors with brake.  
Maße "k1" ist für Bremsenmotoren.

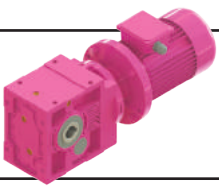

# Ölçü Sayfaları Dimension Pages Abmessungsseiten

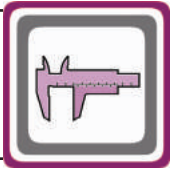

-Mil ucu çekirme deliği DIN 332 sayfa 2 / Tapped center hole to DIN 332, sheet 2 / Zentrierung mit gewinde DIN 332, Blatt 2

KV474.08

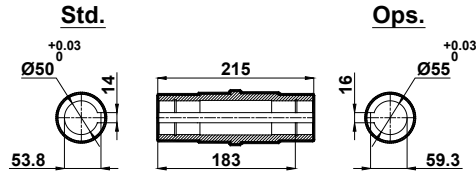
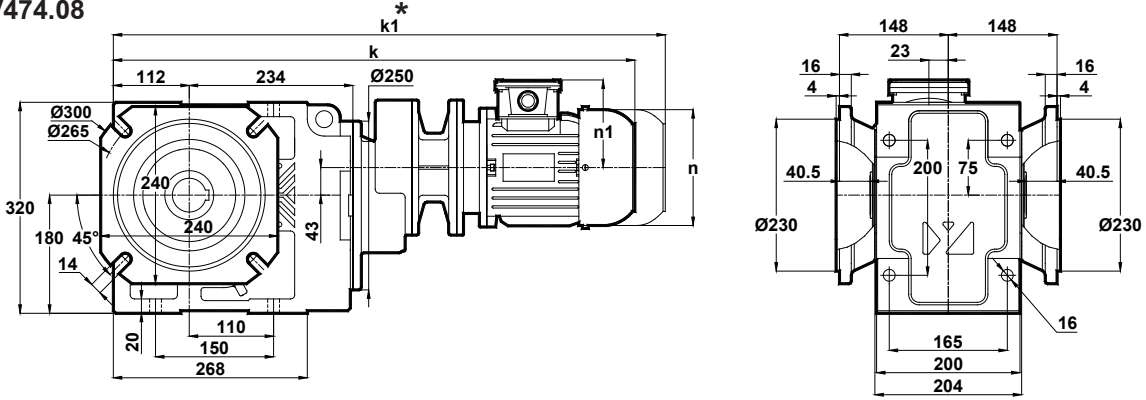

Klemens Pozisyonları  
Terminal Box Positions  
Klemmenkasten Positionen

	71/B5	80/B5
k	720	740
k1	840	860
n	138	156
n1	110	118

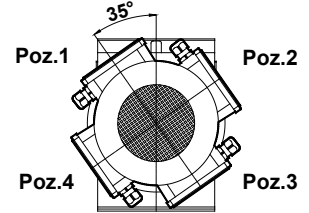

71-80  
Tip / Type / Typ

\* " k1 " Ölçüsü frenli redüktörlere aittir.  
Dimension " k1 " is for motors with brake.  
Maße " k1 " ist für Bremsenmotoren.

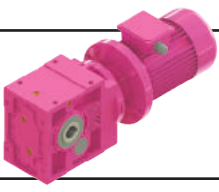

# Ölçü Sayfaları Dimension Pages Abmessungsseiten



-Mil ucu çektirme deliği DIN 332 sayfa 2 / Tapped center hole to DIN 332, sheet 2 / Zentrierung mit gewinde DIN 332, Blatt 2

KV475.00  
KV476.00

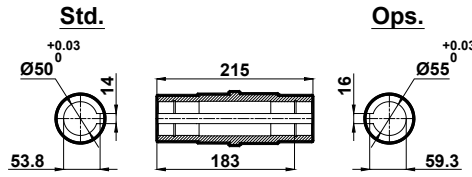
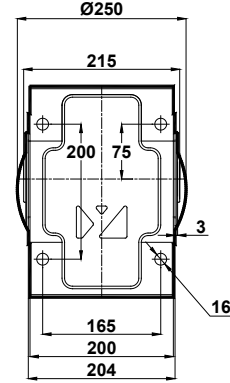
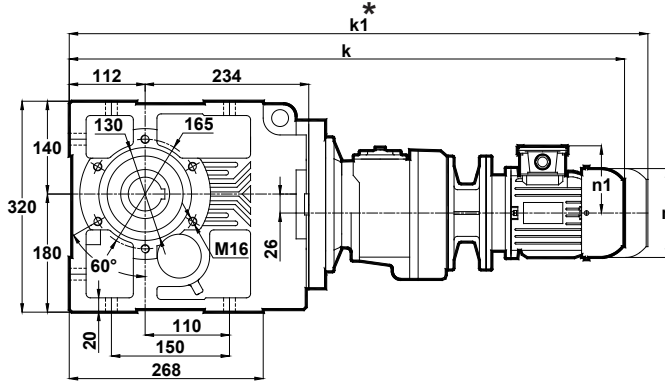

**Klemens Pozisyonları**  
Terminal Box Positions  
Klemmenkasten Positionen

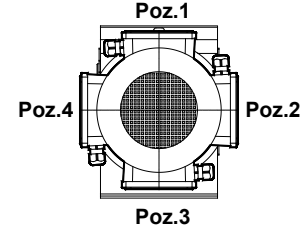

63-71  
Tip / Type / Typ

	63/B5	71/B5
k	822	819
k1	-	939
n	116	138
n1	97	110

KV475.01  
KV476.01

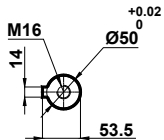
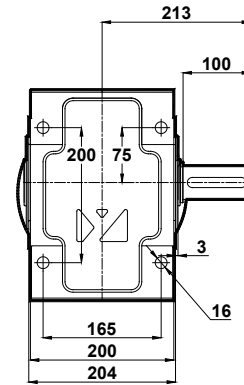
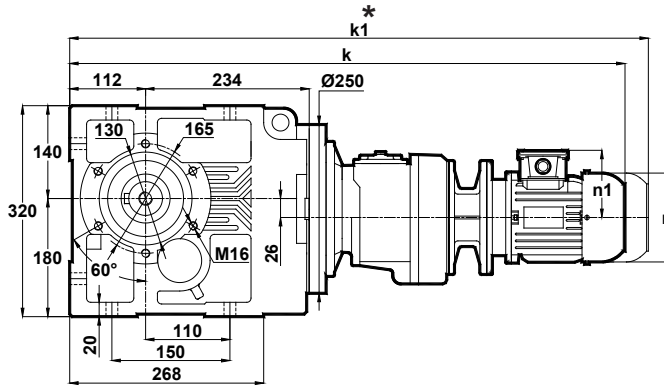

	63/B5	71/B5
k	822	819
k1	-	939
n	116	138
n1	97	110

\* "k1" Ölçüsü frenli redüktörlere aittir.  
Dimension "k1" is for motors with brake.  
Maße "k1" ist für Bremsmotoren.

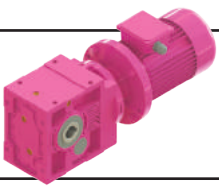

# Ölçü Sayfaları Dimension Pages Abmessungsseiten

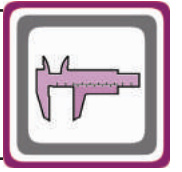

-Mil ucu çekirme deliği DIN 332 sayfa 2 / Tapped center hole to DIN 332, sheet 2 / Zentrierung mit gewinde DIN 332, Blatt 2

KV475.02  
KV476.02

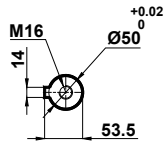
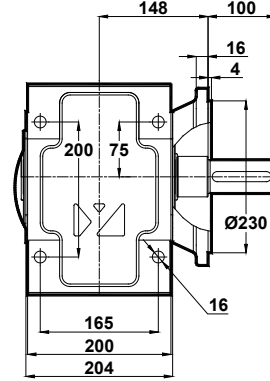
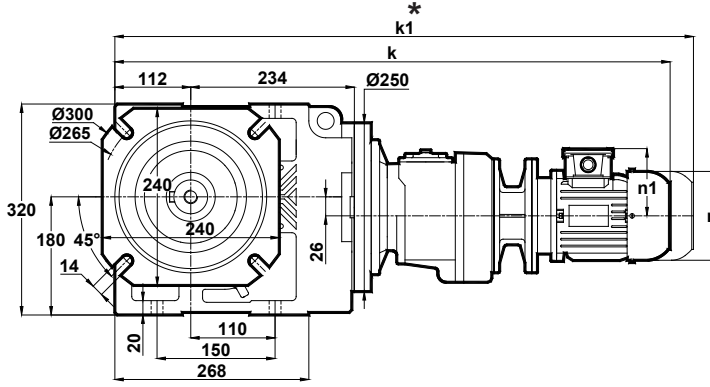

Klemens Pozisyonları  
Terminal Box Positions  
Klemmenkasten Positionen

Poz.1

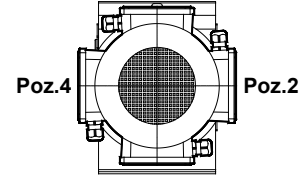

Poz.3

63-71

Tip / Type / Typ

	63/B5	71/B5
k	822	819
k1	-	939
n	116	138
n1	97	110

KV475.03  
KV476.03

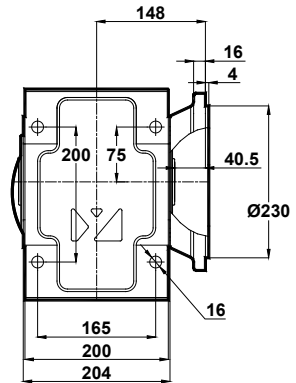
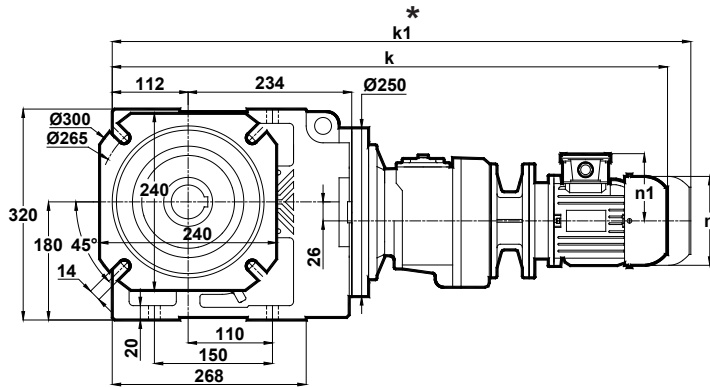

Std.

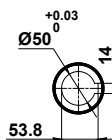

Ops.

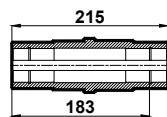
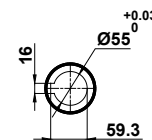

	63/B5	71/B5
k	822	819
k1	-	939
n	116	138
n1	97	110

\* " k1 " Ölçüsü frenli redüktörlere aittir.  
Dimension " k1 " is for motors with brake.  
Maße " k1 " ist für Bremsenmotoren.

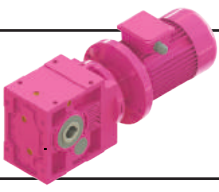

# Ölçü Sayfaları Dimension Pages Abmessungsseiten



-Mil ucu çektirme deliği DIN 332 sayfa 2 / Tapped center hole to DIN 332, sheet 2 / Zentrierung mit gewinde DIN 332, Blatt 2

KV475.04  
KV476.04

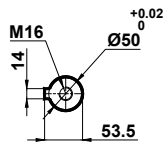
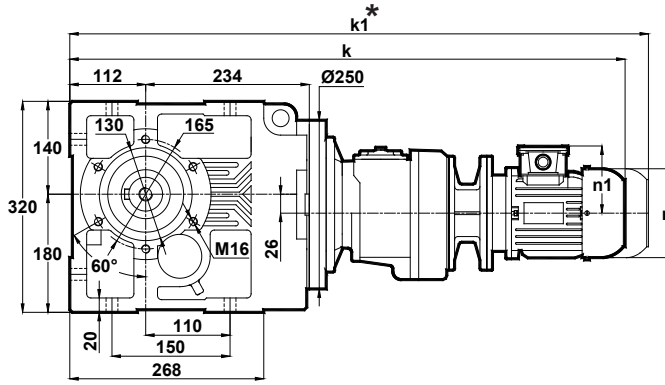

	63/B5	71/B5
k	822	819
k1	-	939
n	116	138
n1	97	110

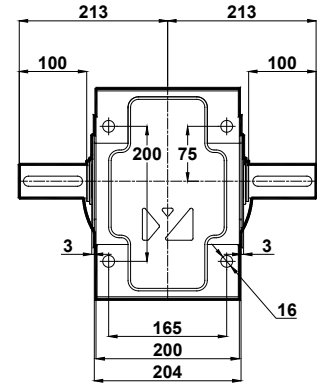

Klemens Pozisyonları  
Terminal Box Positions  
Klemmenkasten Positionen

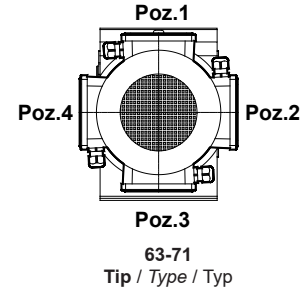

KV475.05  
KV476.05

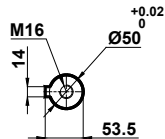
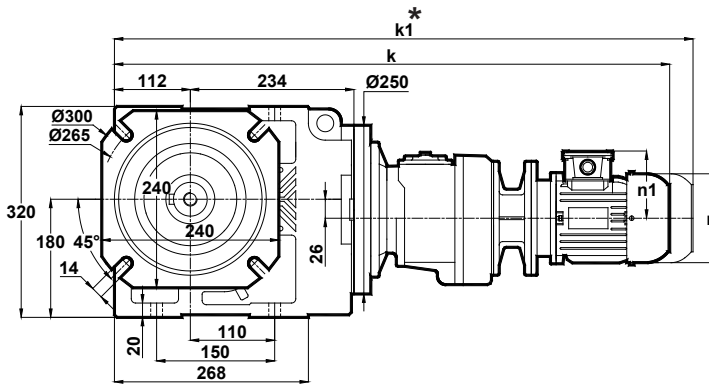

	63/B5	71/B5
k	822	819
k1	-	939
n	116	138
n1	97	110

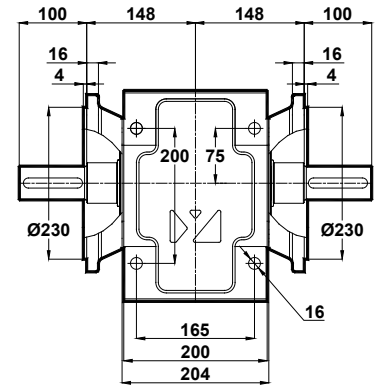

\* " k1 " Ölçüsü frenli redüktörlere aittir.  
Dimension " k1 " is for motors with brake.  
Maße " k1 " ist für Bremsenmotoren.

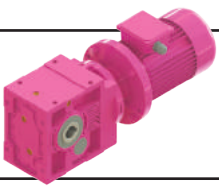

# Ölçü Sayfaları Dimension Pages Abmessungsseiten

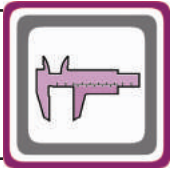

-Mil ucu çektirme deliği DIN 332 sayfa 2 / Tapped center hole to DIN 332, sheet 2 / Zentrierung mit gewinde DIN 332, Blatt 2

KV475.08  
KV476.08

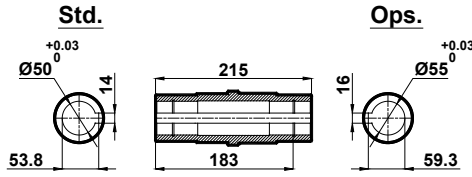
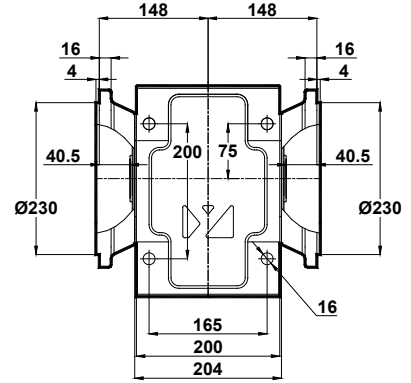
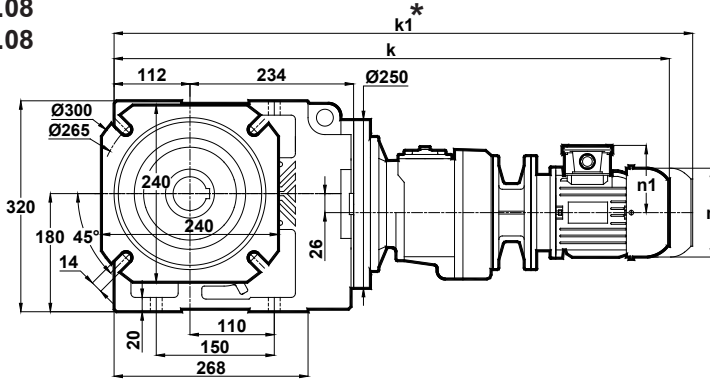

Klemens Pozisyonları  
Terminal Box Positions  
Klemmenkasten Positionen

	63/B5	71/B5
k	822	819
k1	-	939
n	116	138
n1	97	110

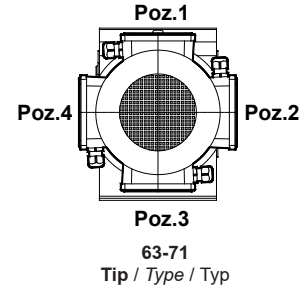

\* " k1 " Ölçüsü frenli redüktörlere aittir.  
Dimension " k1 " is for motors with brake.  
Maße " k1 " ist für Bremsenmotoren.

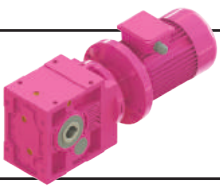

# Ölçü Sayfaları Dimension Pages Abmessungsseiten



-Mil ucu çektirme deliği DIN 332 sayfa 2 / Tapped center hole to DIN 332, sheet 2 / Zentrierung mit gewinde DIN 332, Blatt 2

## KV573.00

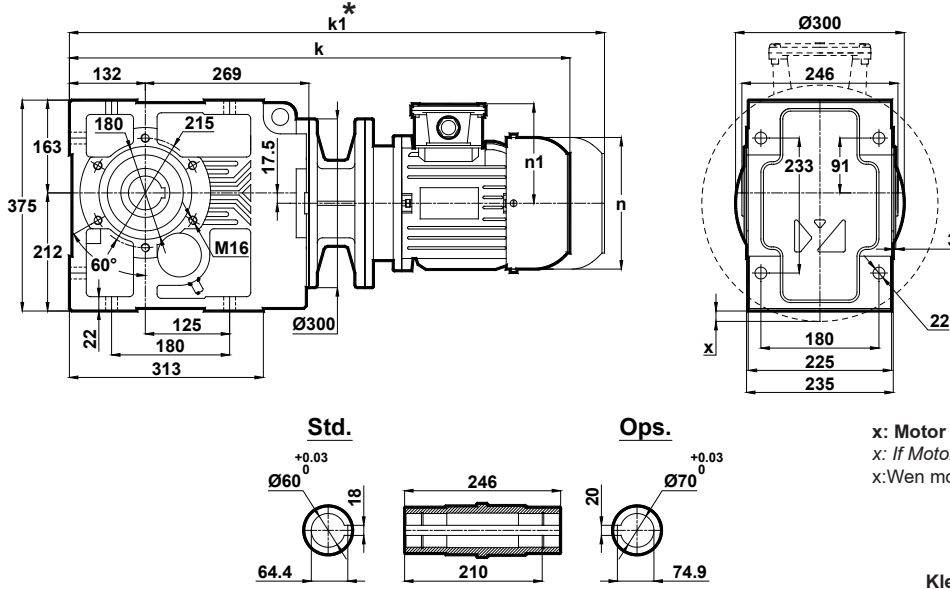

x: Motor Ayak bağlantı yüzeyinin altında ise  
x: If Motor is lower then foot mounting plane  
x: Wenn motor ist niedriger den die Anschlußplatte

Klemens Pozisyonları  
Terminal Box Positions  
Klemmenkasten Positionen

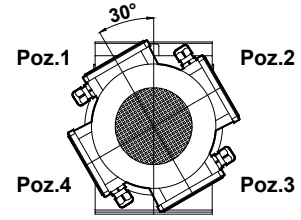

100-112-132-160-180  
Tip / Type / Typ

	100L/B5	112M/B5	132S/B5	132M/B5	160M/B5	160L/B5	180M/B5	180L/B5
k	790	810	875	913	1060	1104	1117	1155
k1	925	945	1020	1058	1230	1274	1287	1325
n	194	218	258	258	310	310	348	348
n1	135	146	168	168	225	225	241	241
x	-	-	-	-	-	-	-	-

## KV573.01

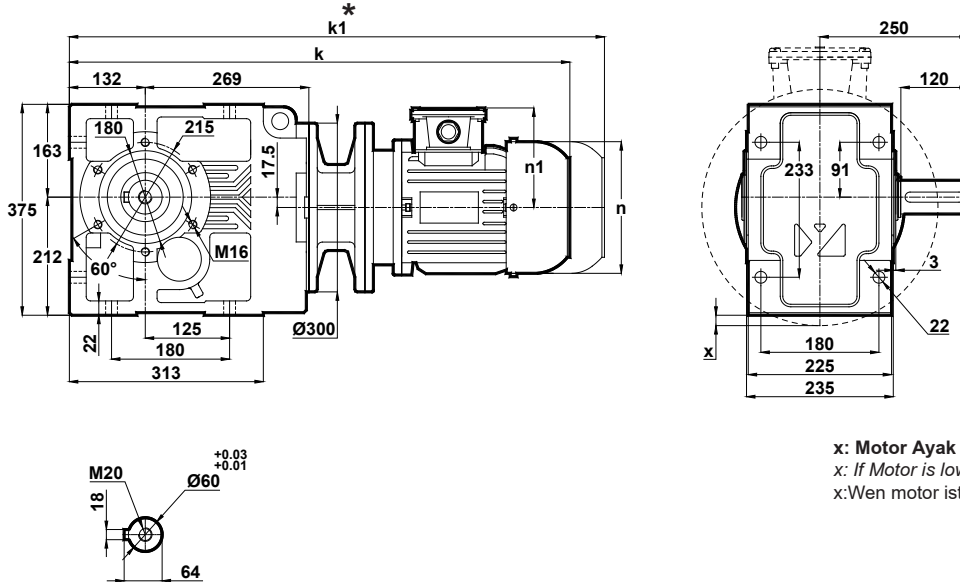

x: Motor Ayak bağlantı yüzeyinin altında ise  
x: If Motor is lower then foot mounting plane  
x: Wenn motor ist niedriger den die Anschlußplatte

	100L/B5	112M/B5	132S/B5	132M/B5	160M/B5	160L/B5	180M/B5	180L/B5
k	790	810	875	913	1060	1104	1117	1155
k1	925	945	1020	1058	1230	1274	1287	1325
n	194	218	258	258	310	310	348	348
n1	135	146	168	168	225	225	241	241
x	-	-	-	-	-	-	-	-

\* "k1" Ölçüsü frenli redüktörlere aittir.  
Dimension "k1" is for motors with brake.  
Maße "k1" ist für Bremsmotoren.

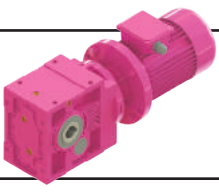

# Ölçü Sayfaları Dimension Pages Abmessungsseiten

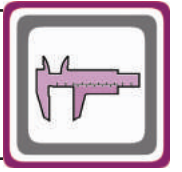

-Mil ucu çektirme deliği DIN 332 sayfa 2 / Tapped center hole to DIN 332, sheet 2 / Zentrierung mit gewinde DIN 332, Blatt 2

## KV573.02

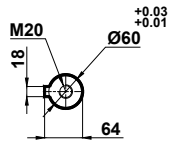
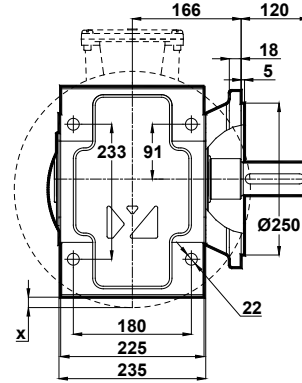
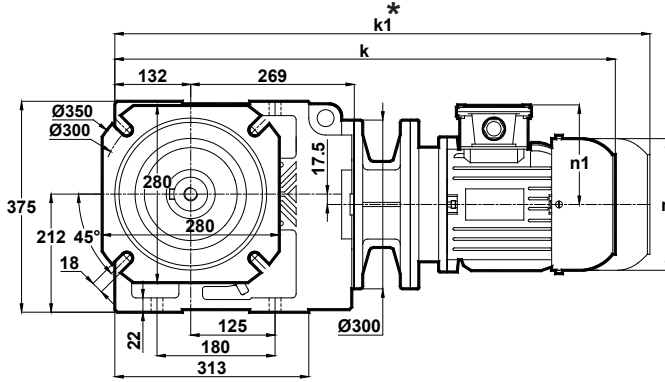

x: Motor Ayak bağlantı yüzeyinin altında ise  
x: If Motor is lower then foot mounting plane  
x: Wenn motor ist niedriger den die Anschlußplatte

	100L/B5	112M/B5	132S/B5	132M/B5	160M/B5	160L/B5	180M/B5	180L/B5
k	790	810	875	913	1060	1104	1117	1155
k1	925	945	1020	1058	1230	1274	1287	1325
n	194	218	258	258	310	310	348	348
n1	135	146	168	168	225	225	241	241
x	-	-	-	-	-	-	-	-

Klemens Pozisyonları  
Terminal Box Positions  
Klemmenkasten Positionen

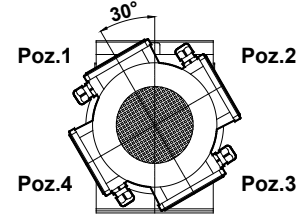

100-112-132-160-180  
Tip / Type / Typ

## KV573.03

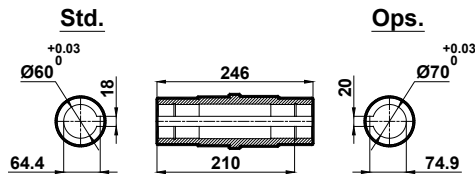
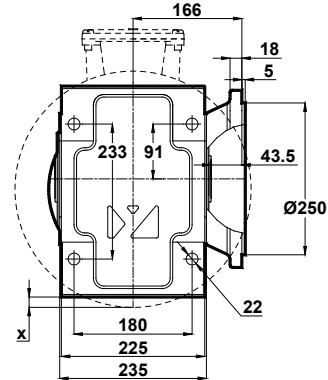
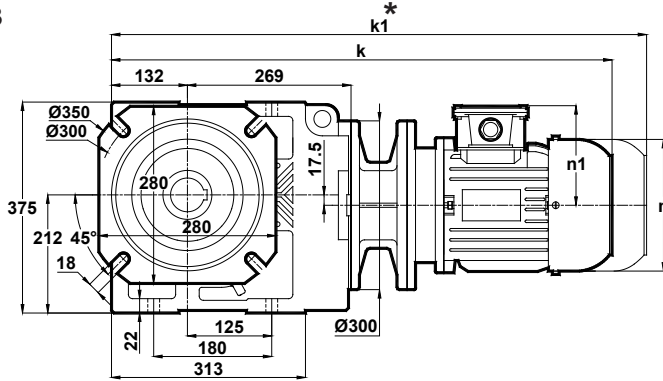

x: Motor Ayak bağlantı yüzeyinin altında ise  
x: If Motor is lower then foot mounting plane  
x: Wenn motor ist niedriger den die Anschlußplatte

	100L/B5	112M/B5	132S/B5	132M/B5	160M/B5	160L/B5	180M/B5	180L/B5
k	790	810	875	913	1060	1104	1117	1155
k1	925	945	1020	1058	1230	1274	1287	1325
n	194	218	258	258	310	310	348	348
n1	135	146	168	168	225	225	241	241
x	-	-	-	-	-	-	-	-

\* " k1 " Ölçüsü frenli redüktörlere aittir.  
Dimension " k1 " is for motors with brake.  
Maße " k1 " ist für Bremsenmotoren.

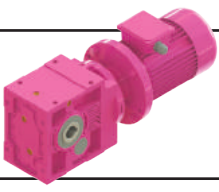

# Ölçü Sayfaları Dimension Pages Abmessungsseiten



-Mil ucu çekirme deliği DIN 332 sayfa 2 / Tapped center hole to DIN 332, sheet 2 / Zentrierung mit gewinde DIN 332, Blatt 2

## KV573.04

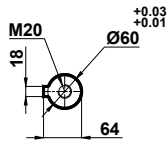
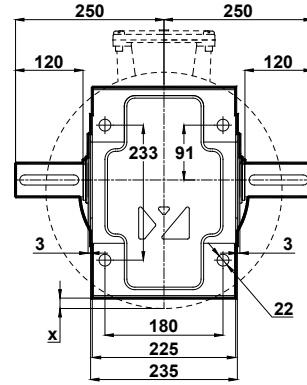
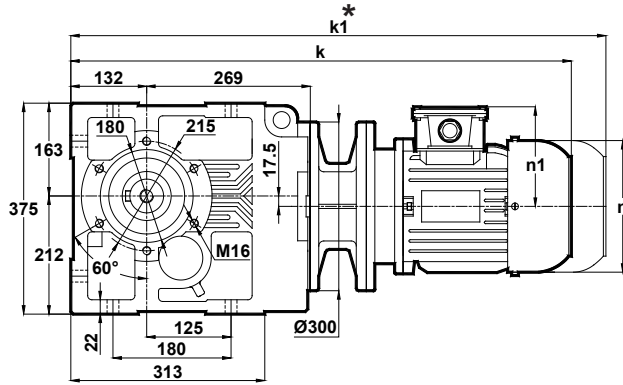

x: Motor Ayak bağlantı yüzeyinin altında ise  
x: If Motor is lower then foot mounting plane  
x: Wenn motor ist niedriger den die Anschlußplatte

	100L/B5	112M/B5	132S/B5	132M/B5	160M/B5	160L/B5	180M/B5	180L/B5
k	790	810	875	913	1060	1104	1117	1155
k1	925	945	1020	1058	1230	1274	1287	1325
n	194	218	258	258	310	310	348	348
n1	135	146	168	168	225	225	241	241
x	-	-	-	-	-	-	-	-

Klemens Pozisyonları  
Terminal Box Positions  
Klemmenkasten Positionen

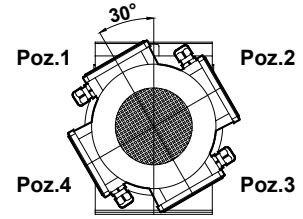

100-112-132-160-180  
Tip / Type / Typ

## KV573.05

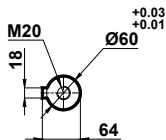
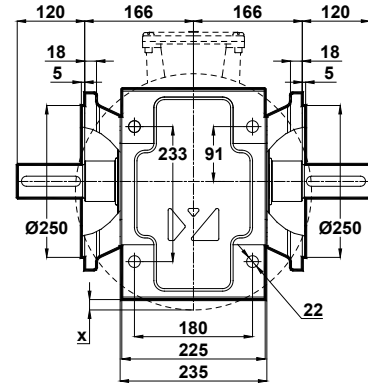
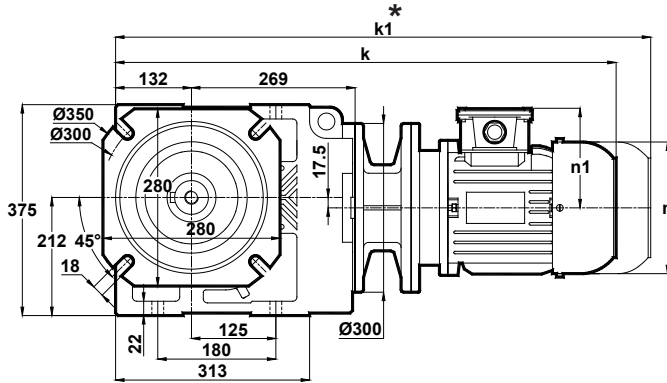

x: Motor Ayak bağlantı yüzeyinin altında ise  
x: If Motor is lower then foot mounting plane  
x: Wenn motor ist niedriger den die Anschlußplatte

	100L/B5	112M/B5	132S/B5	132M/B5	160M/B5	160L/B5	180M/B5	180L/B5
k	790	810	875	913	1060	1104	1117	1155
k1	925	945	1020	1058	1230	1274	1287	1325
n	194	218	258	258	310	310	348	348
n1	135	146	168	168	225	225	241	241
x	-	-	-	-	-	-	-	-

\* "k1" Ölçüsü frenli redüktörlere aittir.  
Dimension "k1" is for motors with brake.  
Maße "k1" ist für Bremsmotoren.

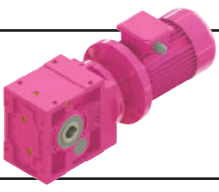

# Ölçü Sayfaları Dimension Pages Abmessungsseiten

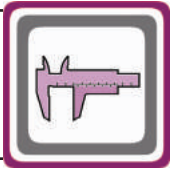

-Mil ucu çekirme deliği DIN 332 sayfa 2 / Tapped center hole to DIN 332, sheet 2 / Zentrierung mit gewinde DIN 332, Blatt 2

KV573.08

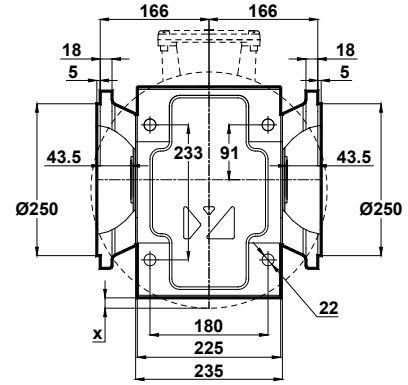
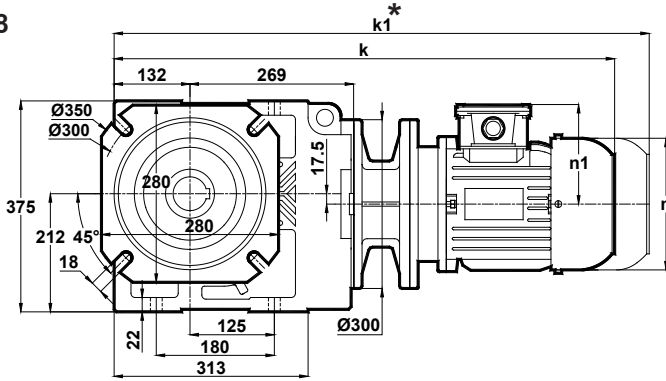

Std.

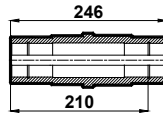
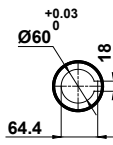

Ops.

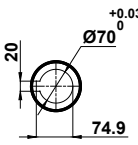

x: Motor Ayak bağlantı yüzeyinin altında ise  
x: If Motor is lower then foot mounting plane  
x: Wenn motor ist niedriger den die Anschlußplatte

	100L/B5	112M/B5	132S/B5	132M/B5	160M/B5	160L/B5	180M/B5	180L/B5
k	790	810	875	913	1060	1104	1117	1155
k1	925	945	1020	1058	1230	1274	1287	1325
n	194	218	258	258	310	310	348	348
n1	135	146	168	168	225	225	241	241
x	-	-	-	-	-	-	-	-

Klemens Pozisyonları  
Terminal Box Positions  
Klemmenkasten Positionen

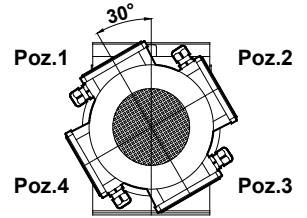

100-112-132-160-180  
Tip / Type / Typ

\* " k1 " Ölçüsü frenli redüktörlere aittir.  
Dimension " k1 " is for motors with brake.  
Maße " k1 " ist für Bremsenmotoren.

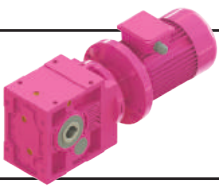

# Ölçü Sayfaları Dimension Pages Abmessungsseiten



-Mil ucu çektirme deliği DIN 332 sayfa 2 / Tapped center hole to DIN 332, sheet 2 / Zentrierung mit gewinde DIN 332, Blatt 2

## KV574.00

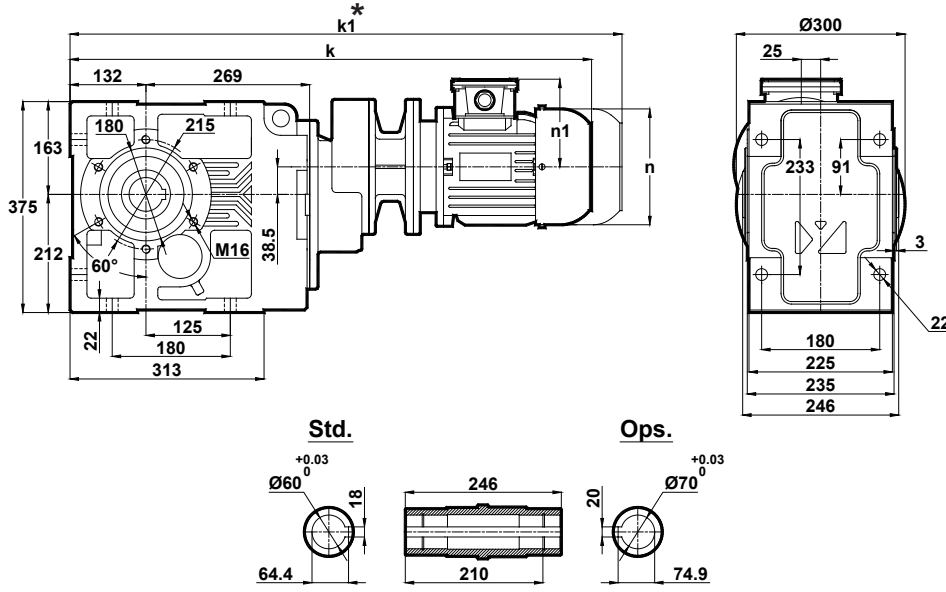

	71/B5	80/B5	90S/B5	90L/B5	100L/B5
k	773	793	813	838	887
k1	893	913	938	963	1022
n	138	156	176	176	194
n1	110	118	126	126	135

Klemens Pozisyonları  
Terminal Box Positions  
Klemmenkasten Positionen

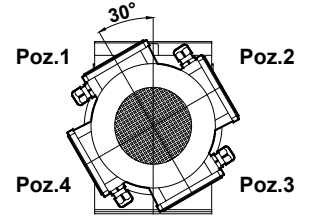

71-80-90-100  
Tip / Type / Typ

## KV574.01

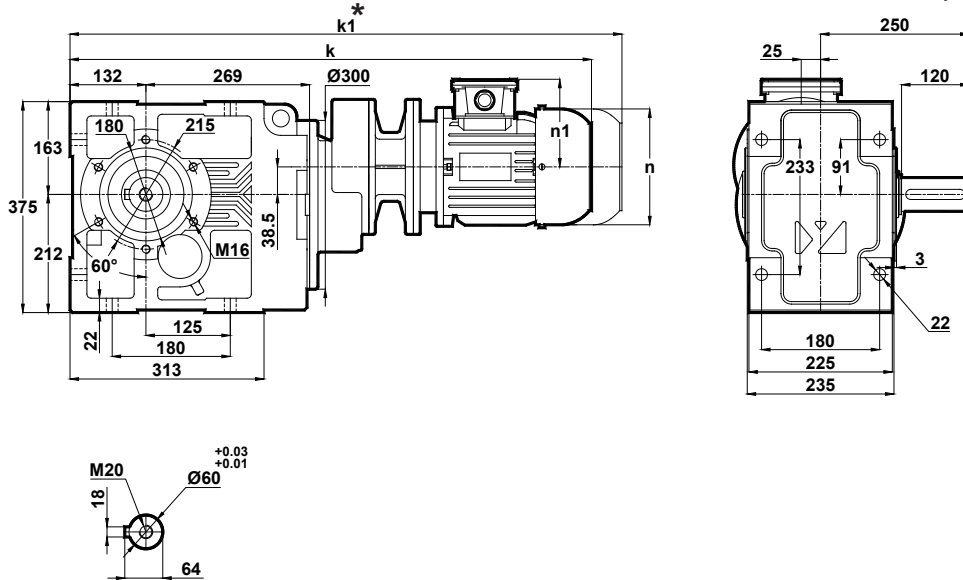

	71/B5	80/B5	90S/B5	90L/B5	100L/B5
k	773	793	813	838	887
k1	893	913	938	963	1022
n	138	156	176	176	194
n1	110	118	126	126	135

\* " k1 " Ölçüsü frenli redüktörlere aittir.  
Dimension " k1 " is for motors with brake.  
Maße " k1 " ist für Bremsenmotoren.

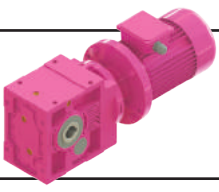

# Ölçü Sayfaları Dimension Pages Abmessungsseiten

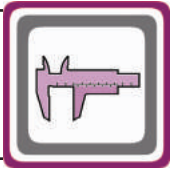

-Mil ucu çekirme deliği DIN 332 sayfa 2 / Tapped center hole to DIN 332, sheet 2 / Zentrierung mit gewinde DIN 332, Blatt 2

## KV574.02

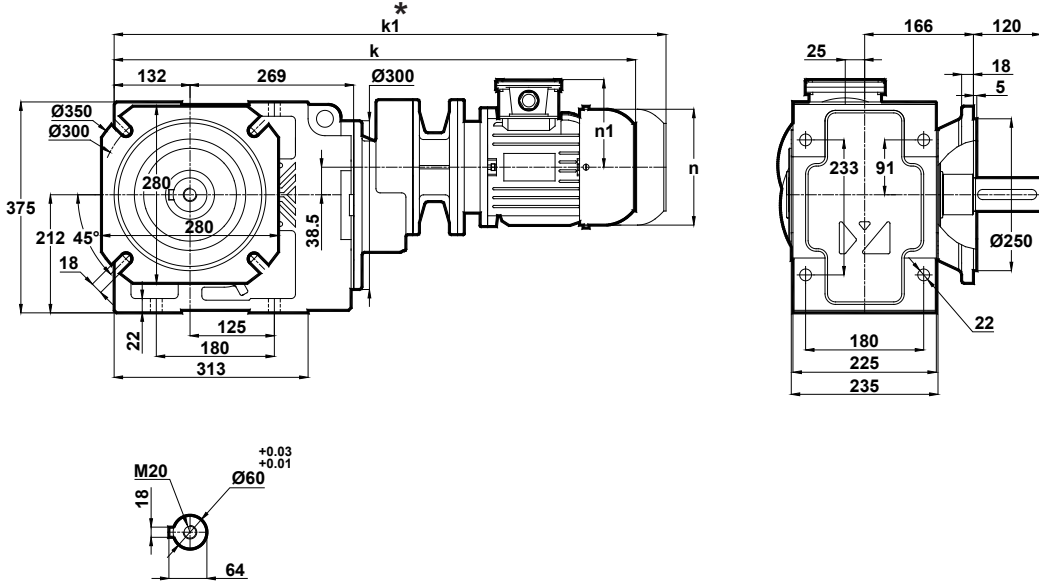

	71/B5	80/B5	90S/B5	90L/B5	100L/B5
k	773	793	813	838	887
k1	893	913	938	963	1022
n	138	156	176	176	194
n1	110	118	126	126	135

Klemens Pozisyonları  
Terminal Box Positions  
Klemmenkasten Positionen

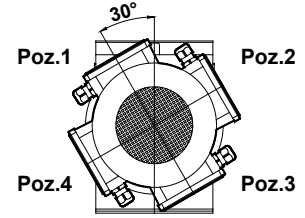

71-80-90-100  
Tip / Type / Typ

## KV574.03

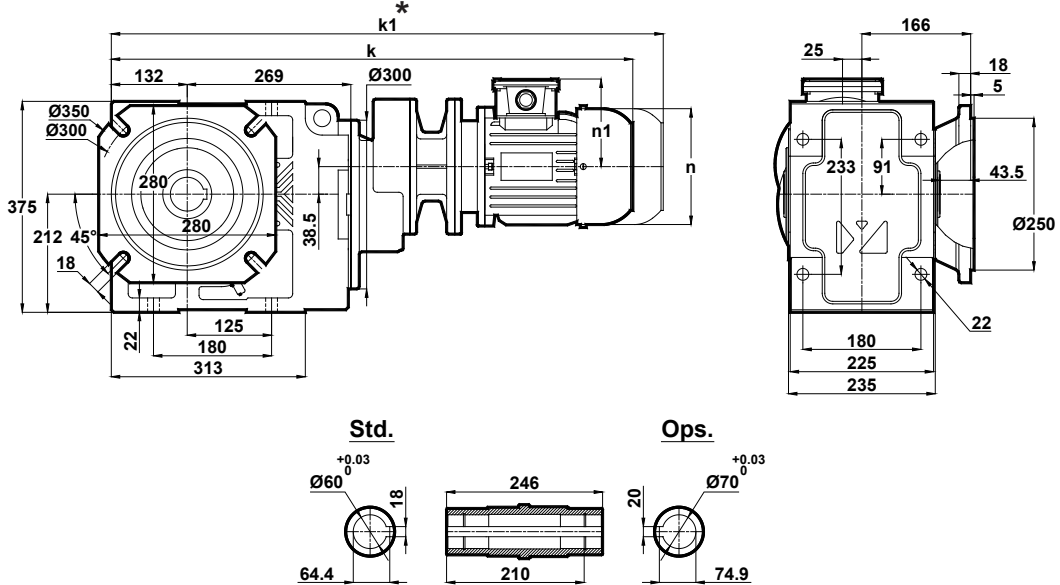

Std.

Ops.

	71/B5	80/B5	90S/B5	90L/B5	100L/B5
k	773	793	813	838	887
k1	893	913	938	963	1022
n	138	156	176	176	194
n1	110	118	126	126	135

\* " k1 " Ölçüsü frenli redüktörlere aittir.  
Dimension " k1 " is for motors with brake.  
Maße " k1 " ist für Bremsenmotoren.

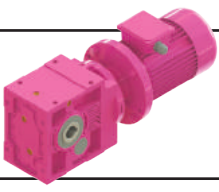

# Ölçü Sayfaları Dimension Pages Abmessungsseiten



-Mil ucu çekirme deliği DIN 332 sayfa 2 / Tapped center hole to DIN 332, sheet 2 / Zentrierung mit gewinde DIN 332, Blatt 2

## KV574.04

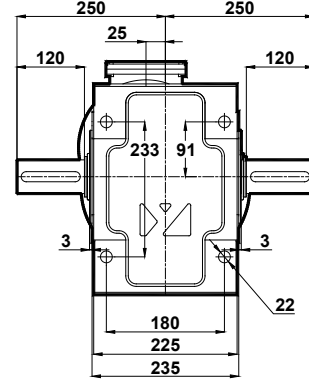
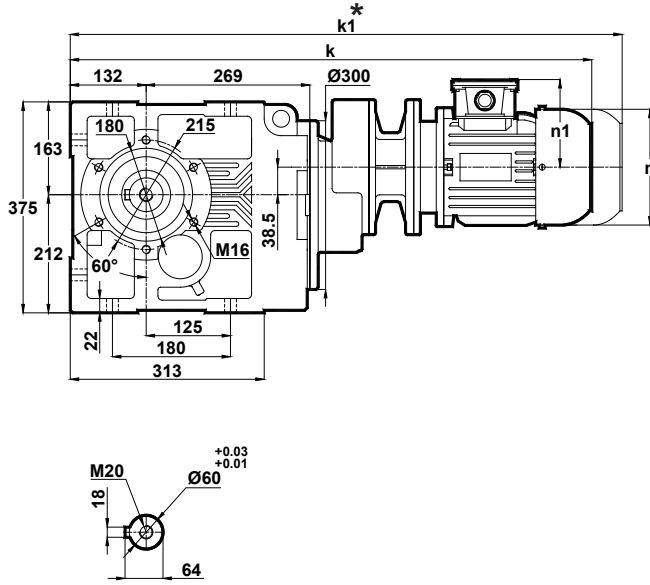

Klemens Pozisyonları  
Terminal Box Positions  
Klemmenkasten Positionen

	71/B5	80/B5	90S/B5	90L/B5	100L/B5
k	773	793	813	838	887
k1	893	913	938	963	1022
n	138	156	176	176	194
n1	110	118	126	126	135

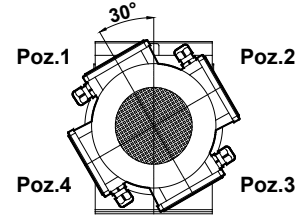

71-80-90-100  
Tip / Type / Typ

## KV574.05

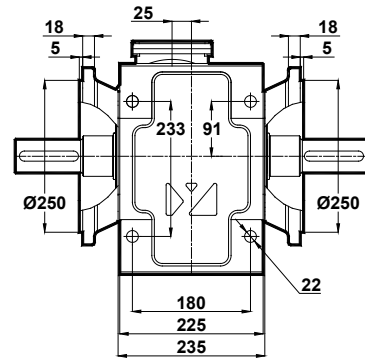
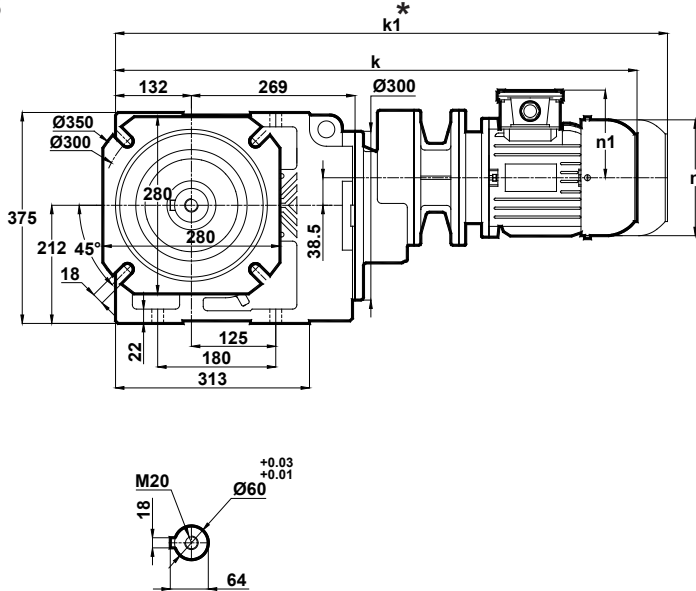

	71/B5	80/B5	90S/B5	90L/B5	100L/B5
k	773	793	813	838	887
k1	893	913	938	963	1022
n	138	156	176	176	194
n1	110	118	126	126	135

\* "k1" Ölçüsü frenli redüktörlere aittir.  
Dimension "k1" is for motors with brake.  
Maße "k1" ist für Bremsenmotoren.

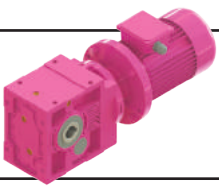

# Ölçü Sayfaları Dimension Pages Abmessungsseiten

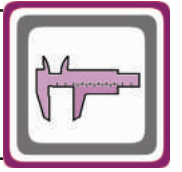

-Mil ucu çektirme deliği DIN 332 sayfa 2 / Tapped center hole to DIN 332, sheet 2 / Zentrierung mit gewinde DIN 332, Blatt 2

KV574.08

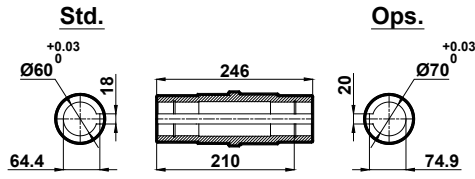
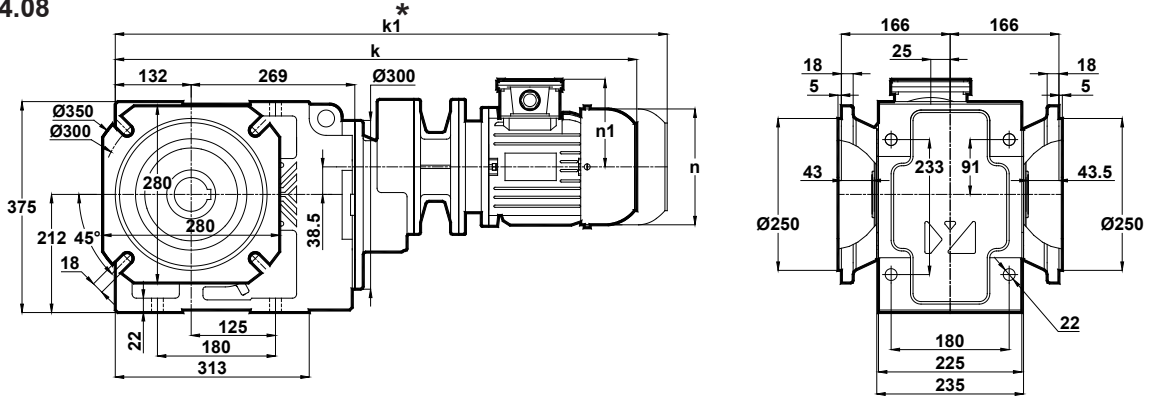

Klemens Pozisyonları  
Terminal Box Positions  
Klemmenkasten Positionen

	71/B5	80/B5	90S/B5	90L/B5	100L/B5
k	773	793	813	838	887
k1	893	913	938	963	1022
n	138	156	176	176	194
n1	110	118	126	126	135

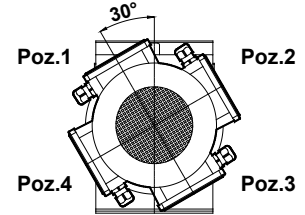

71-80-90-100  
Tip / Type / Typ

\* " k1 " Ölçüsü frenli redüktörlere aittir.  
Dimension " k1 " is for motors with brake.  
Maße " k1 " ist für Bremsenmotoren.

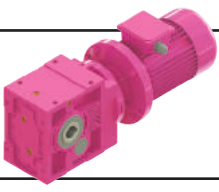

# Ölçü Sayfaları Dimension Pages Abmessungsseiten



-Mil ucu çekirme deliği DIN 332 sayfa 2 / Tapped center hole to DIN 332, sheet 2 / Zentrierung mit gewinde DIN 332, Blatt 2

KV575.00  
KV576.00

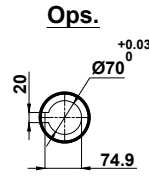
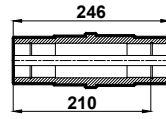
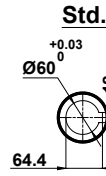
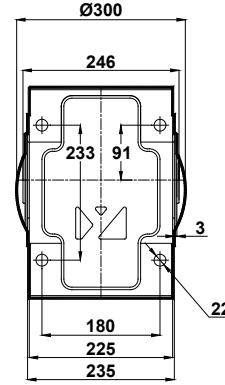
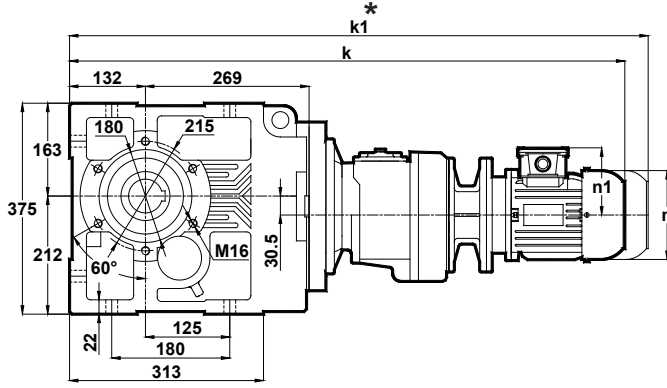

	63/B5	71/B5	80/B5
k	877	874	923
k1	-	994	1043
n	116	138	156
n1	97	110	118

**Klemens Pozisyonları**  
Terminal Box Positions  
Klemmenkasten Positionen

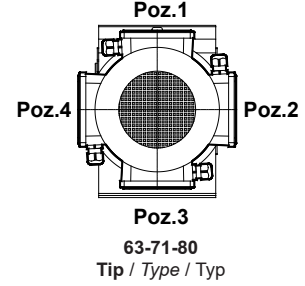

KV575.01  
KV576.01

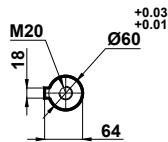
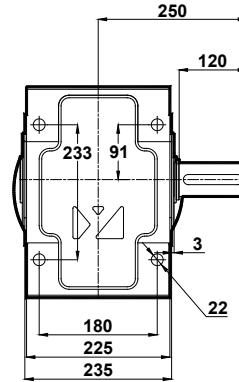
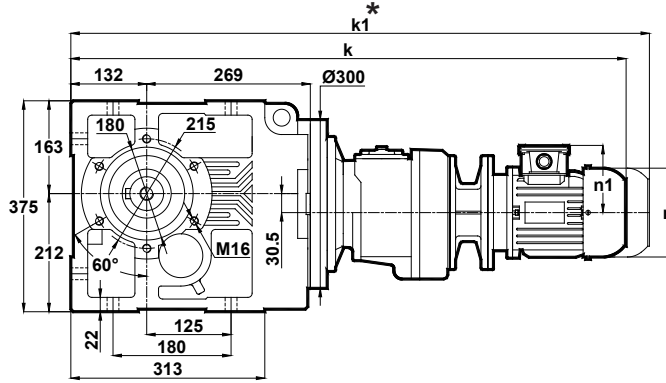

	63/B5	71/B5	80/B5
k	877	874	923
k1	-	994	1043
n	116	138	156
n1	97	110	118

\* "k1" Ölçüsü frenli redüktörlere aittir.  
Dimension "k1" is for motors with brake.  
Maße "k1" ist für Bremsenmotoren.

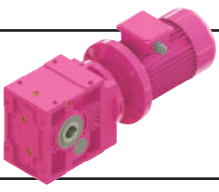

# Ölçü Sayfaları Dimension Pages Abmessungsseiten

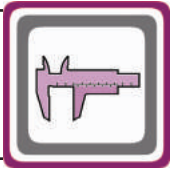

-Mil ucu çekirme deliği DIN 332 sayfa 2 / Tapped center hole to DIN 332, sheet 2 / Zentrierung mit gewinde DIN 332, Blatt 2

KV575.02  
KV576.02

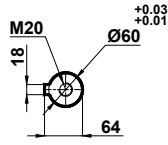
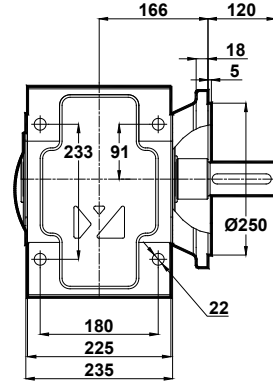
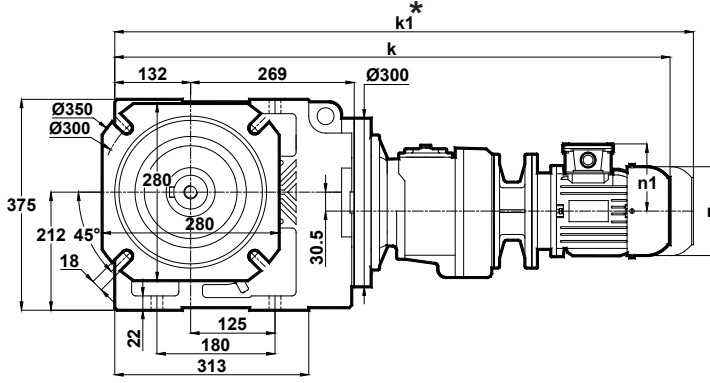

Klemens Pozisyonları  
Terminal Box Positions  
Klemmenkasten Positionen

	63/B5	71/B5	80/B5
k	877	874	923
k1	-	994	1043
n	116	138	156
n1	97	110	118

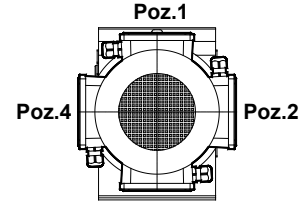

Poz.3  
63-71-80  
Tip / Type / Typ

KV575.03  
KV576.03

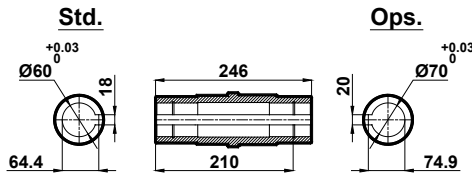
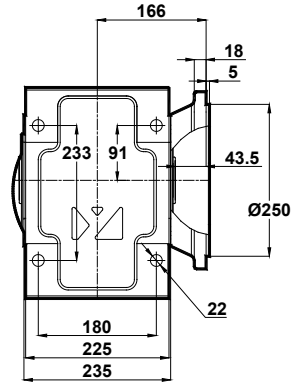
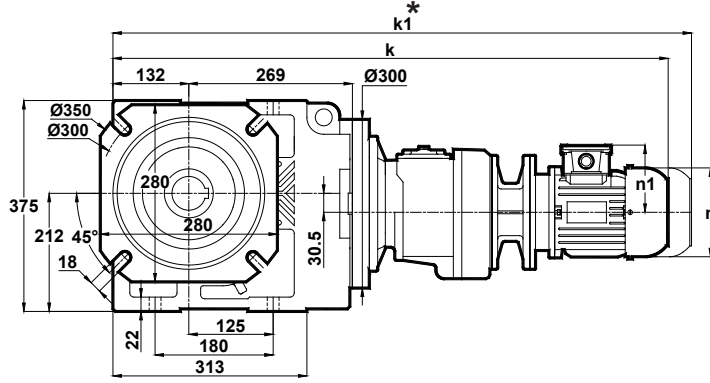

	63/B5	71/B5	80/B5
k	877	874	923
k1	-	994	1043
n	116	138	156
n1	97	110	118

\* " k1 " Ölçüsü frenli redüktörlere aittir.  
Dimension " k1 " is for motors with brake.  
Maße " k1 " ist für Bremsenmotoren.

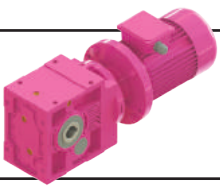

# Ölçü Sayfaları Dimension Pages Abmessungsseiten



-Mil ucu çektirme deliği DIN 332 sayfa 2 / Tapped center hole to DIN 332, sheet 2 / Zentrierung mit gewinde DIN 332, Blatt 2

KV575.04  
KV576.04

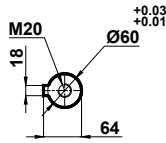
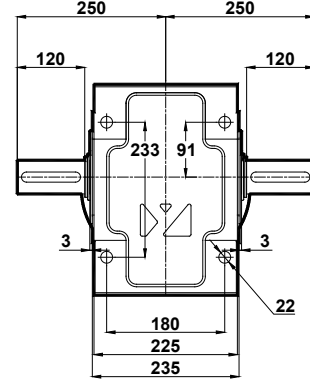
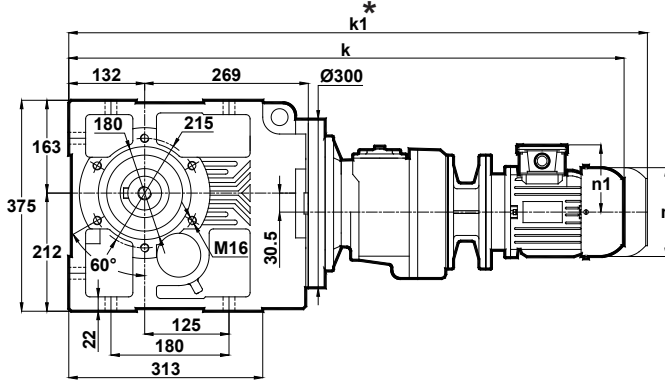

	63/B5	71/B5	80/B5
k	877	874	923
k1	-	994	1043
n	116	138	156
n1	97	110	118

Klemens Pozisyonları  
Terminal Box Positions  
Klemmenkasten Positionen

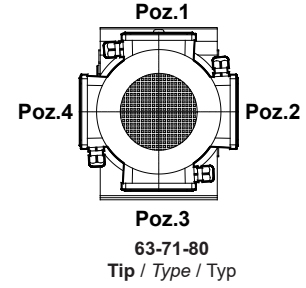

KV575.05  
KV576.05

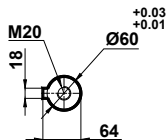
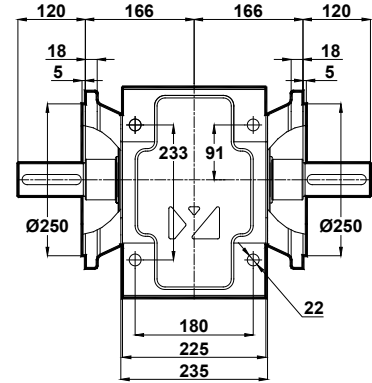
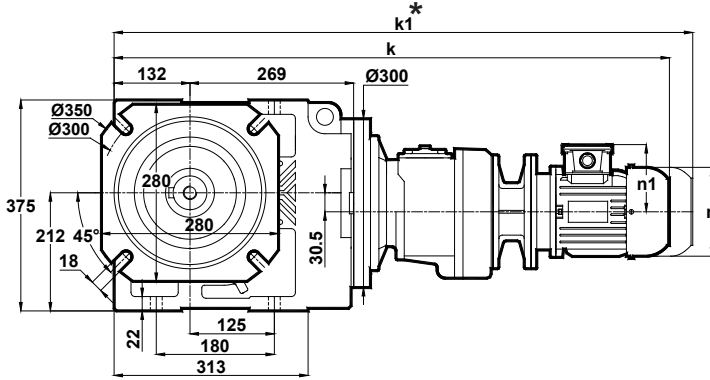

	63/B5	71/B5	80/B5
k	877	874	923
k1	-	994	1043
n	116	138	156
n1	97	110	118

\* " k1 " Ölçüsü frenli redüktörlere aittir.  
Dimension " k1 " is for motors with brake.  
Maße " k1 " ist für Bremsenmotoren.

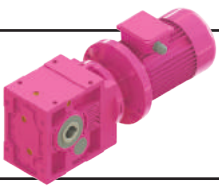

# Ölçü Sayfaları Dimension Pages Abmessungenseiten

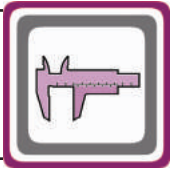

-Mil ucu çektirme deliği DIN 332 sayfa 2 / Tapped center hole to DIN 332, sheet 2 / Zentrierung mit gewinde DIN 332, Blatt 2

KV575.08  
KV576.08

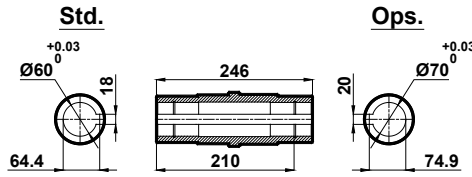
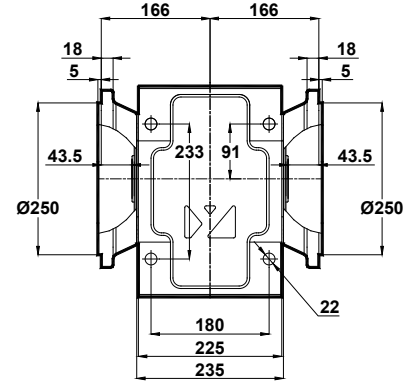
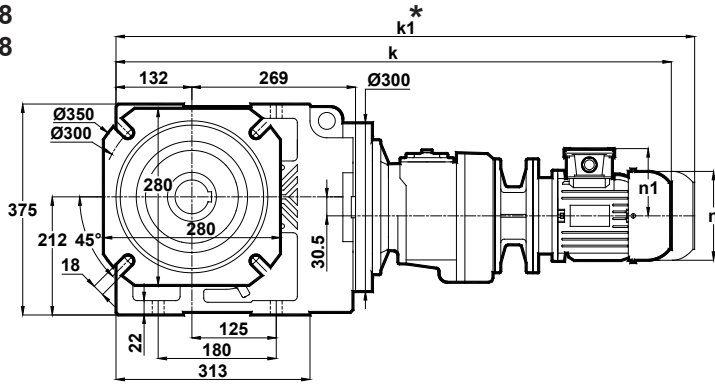

	63/B5	71/B5	80/B5
k	877	874	923
k1	-	994	1043
n	116	138	156
n1	97	110	118

Klemens Pozisyonları  
Terminal Box Positions  
Klemmenkasten Positionen

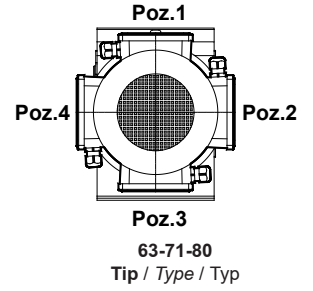

\* " k1 " Ölçüsü frenli redüktörlere aittir.  
Dimension " k1 " is for motors with brake.  
Maße " k1 " ist für Bremsenmotoren.

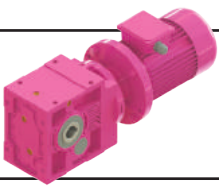

# Ölçü Sayfaları Dimension Pages Abmessungsseiten



-Mil ucu çektirme deliği DIN 332 sayfa 2 / Tapped center hole to DIN 332, sheet 2 / Zentrierung mit gewinde DIN 332, Blatt 2

## KV673.00

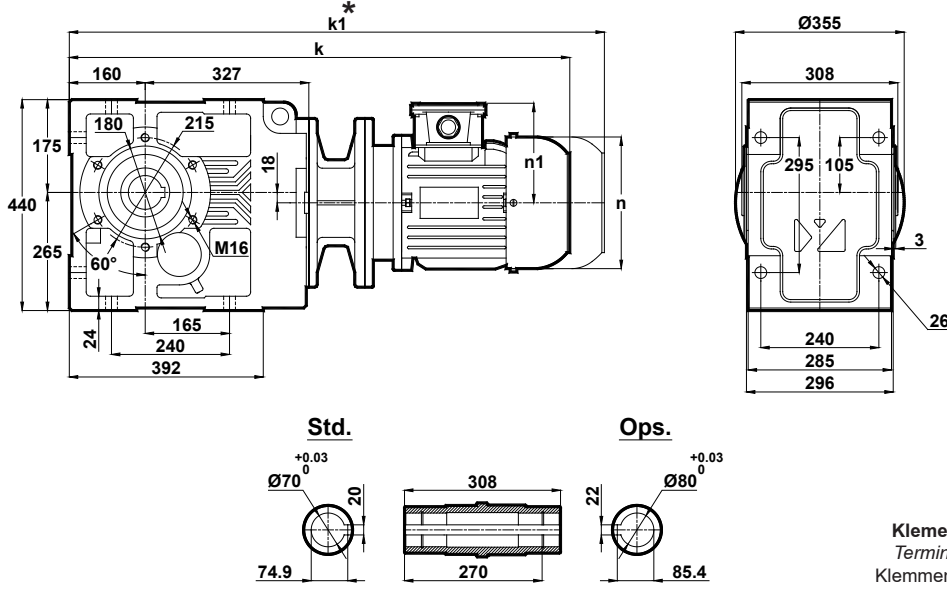

Klemens Pozisyonları  
Terminal Box Positions  
Klemmenkasten Positionen

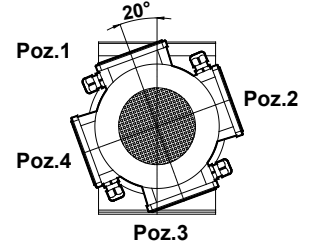

100-112-132-160-180-200-225  
Tip / Type / Typ

	100L/B5	112M/B5	132S/B5	132M/B5	160M/B5	160L/B5	180M/B5	180L/B5	200L/B5	225S/B5	225M/B5
k	872	892	951	989	1136	1180	1193	1231	1303	1374	1399
k1	1007	1027	1096	1134	1306	1350	1363	1401	1503	-	-
n	194	218	258	258	310	310	348	348	390	433	433
n1	135	146	168	168	225	225	241	241	275	285	285

## KV673.01

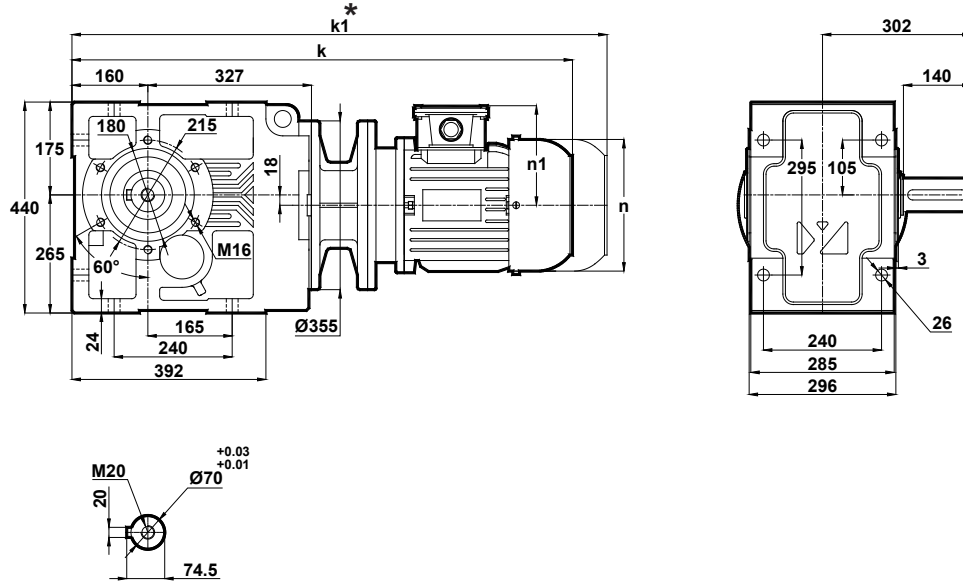

	100L/B5	112M/B5	132S/B5	132M/B5	160M/B5	160L/B5	180M/B5	180L/B5	200L/B5	225S/B5	225M/B5
k	872	892	951	989	1136	1180	1193	1231	1303	1374	1399
k1	1007	1027	1096	1134	1306	1350	1363	1401	1503	-	-
n	194	218	258	258	310	310	348	348	390	433	433
n1	135	146	168	168	225	225	241	241	275	285	285

\* "k1" Ölçüsü frenli redüktörlere aittir.  
Dimension "k1" is for motors with brake.  
Maße "k1" ist für Bremsenmotoren.

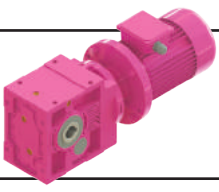

# Ölçü Sayfaları Dimension Pages Abmessungsseiten

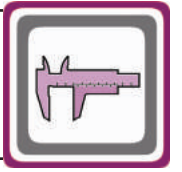

-Mil ucu çekirme deliği DIN 332 sayfa 2 / Tapped center hole to DIN 332, sheet 2 / Zentrierung mit gewinde DIN 332, Blatt 2

## KV673.02

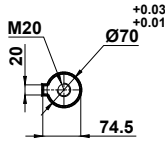
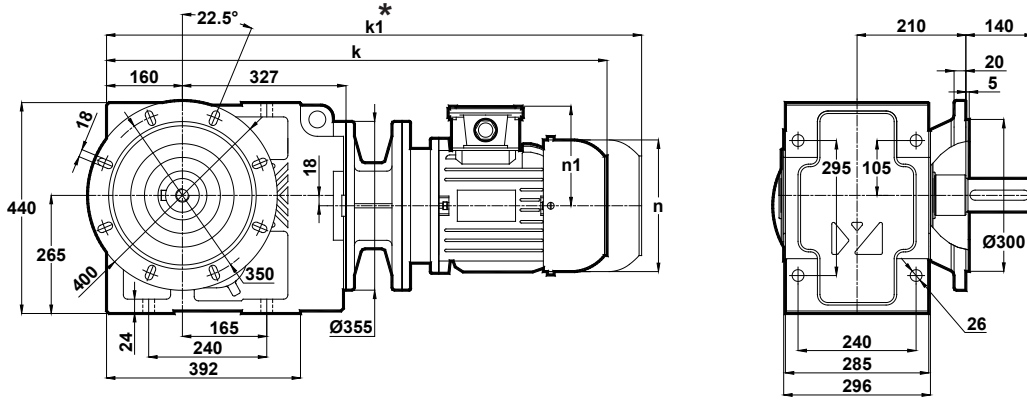

Klemens Pozisyonları  
Terminal Box Positions  
Klemmenkasten Positionen

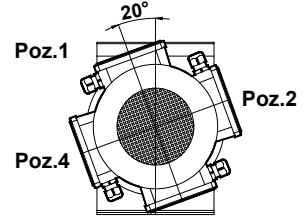

Poz.3

100-112-132-160-180-200-225  
Tip / Type / Typ

	100L/B5	112M/B5	132S/B5	132M/B5	160M/B5	160L/B5	180M/B5	180L/B5	200L/B5	225S/B5	225M/B5
k	872	892	951	989	1136	1180	1193	1231	1303	1374	1399
k1	1007	1027	1096	1134	1306	1350	1363	1401	1503	-	-
n	194	218	258	258	310	310	348	348	390	433	433
n1	135	146	168	168	225	225	241	241	275	285	285

## KV673.03

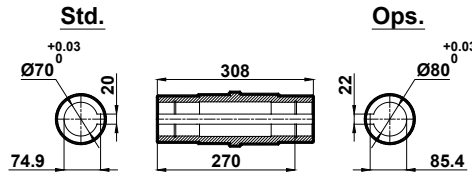
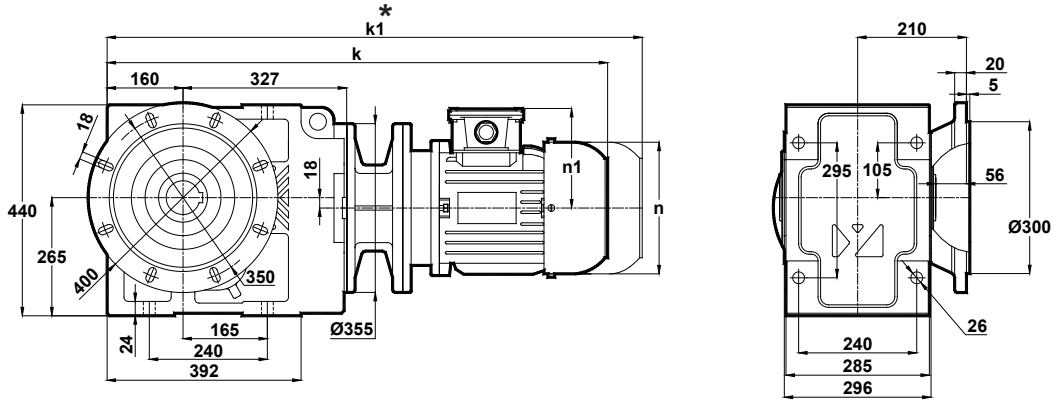

	100L/B5	112M/B5	132S/B5	132M/B5	160M/B5	160L/B5	180M/B5	180L/B5	200L/B5	225S/B5	225M/B5
k	872	892	951	989	1136	1180	1193	1231	1303	1374	1399
k1	1007	1027	1096	1134	1306	1350	1363	1401	1503	-	-
n	194	218	258	258	310	310	348	348	390	433	433
n1	135	146	168	168	225	225	241	241	275	285	285

\* "k1" Ölçüsü frenli redüktörlere aittir.  
Dimension "k1" is for motors with brake.  
Maße "k1" ist für Bremsenmotoren.

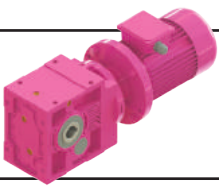

# Ölçü Sayfaları Dimension Pages Abmessungsseiten



-Mil ucu çekirme deliği DIN 332 sayfa 2 / Tapped center hole to DIN 332, sheet 2 / Zentrierung mit gewinde DIN 332, Blatt 2

## KV673.04

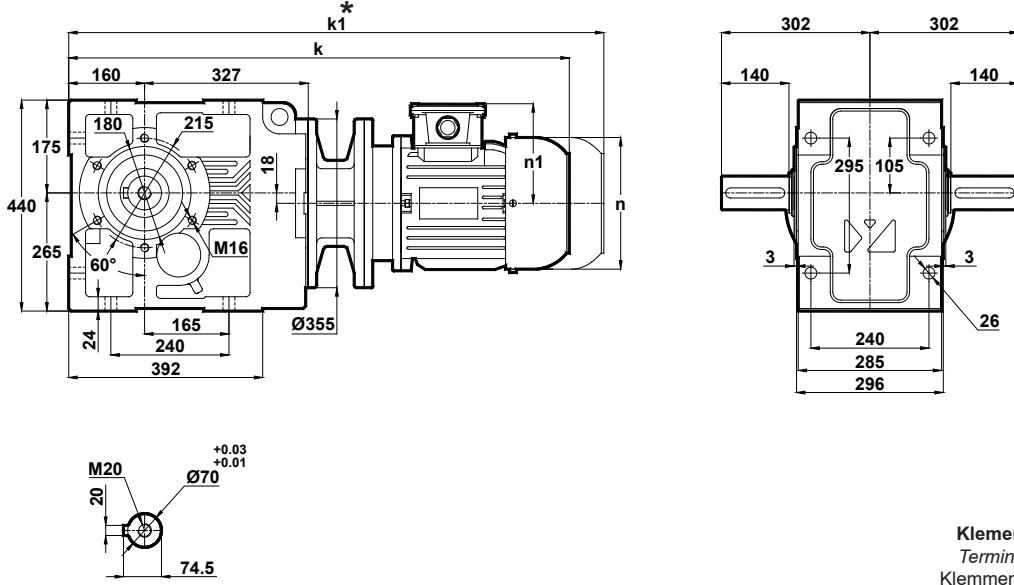

Klemens Pozisyonları  
Terminal Box Positions  
Klemmenkasten Positionen

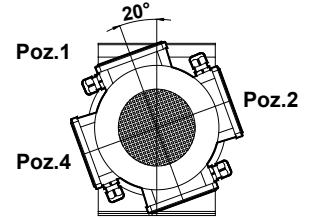

Poz.3  
100-112-132-160-180-200-225  
Tip / Type / Typ

	100L/B5	112M/B5	132S/B5	132M/B5	160M/B5	160L/B5	180M/B5	180L/B5	200L/B5	225S/B5	225M/B5
k	872	892	951	989	1136	1180	1193	1231	1303	1374	1399
k1	1007	1027	1096	1134	1306	1350	1363	1401	1503	-	-
n	194	218	258	258	310	310	348	348	390	433	433
n1	135	146	168	168	225	225	241	241	275	285	285

## KV673.05

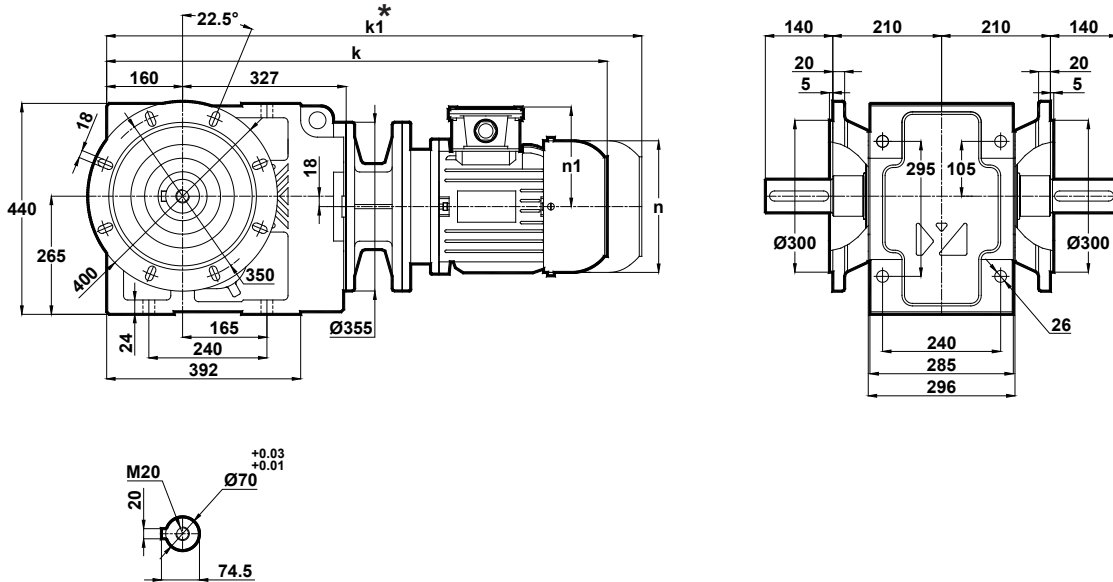

	100L/B5	112M/B5	132S/B5	132M/B5	160M/B5	160L/B5	180M/B5	180L/B5	200L/B5	225S/B5	225M/B5
k	872	892	951	989	1136	1180	1193	1231	1303	1374	1399
k1	1007	1027	1096	1134	1306	1350	1363	1401	1503	-	-
n	194	218	258	258	310	310	348	348	390	433	433
n1	135	146	168	168	225	225	241	241	275	285	285

\* "k1" Ölçüsü frenli redüktörlere aittir.  
Dimension "k1" is for motors with brake.  
Maße "k1" ist für Bremsenmotoren.

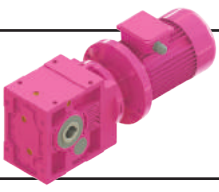

# Ölçü Sayfaları Dimension Pages Abmessungsseiten

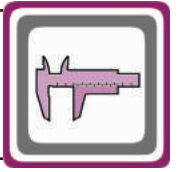

-Mil ucu çektirme deliği DIN 332 sayfa 2 / Tapped center hole to DIN 332, sheet 2 / Zentrierung mit gewinde DIN 332, Blatt 2

KV673.08

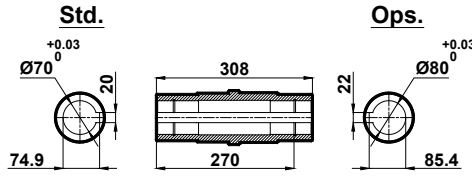
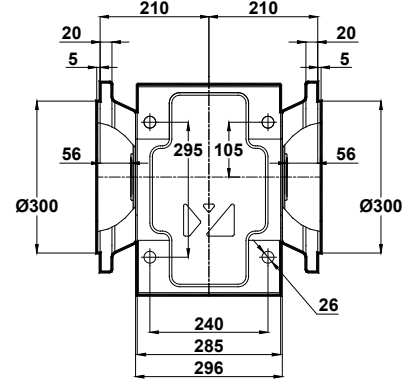
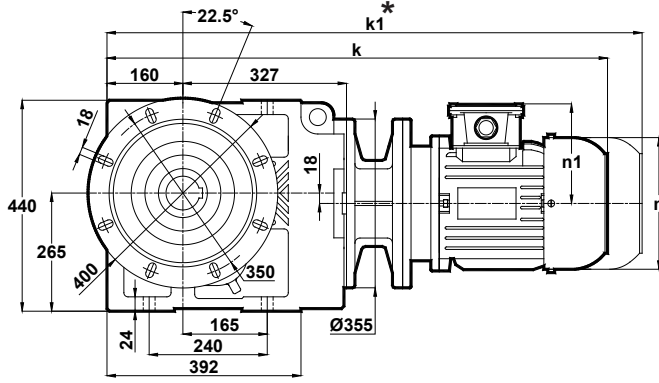

Klemens Pozisyonları  
Terminal Box Positions  
Klemmenkasten Positionen

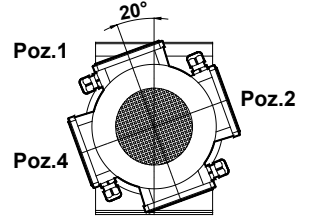

100-112-132-160-180-200-225  
Tip / Type / Typ

	100L/B5	112M/B5	132S/B5	132M/B5	160M/B5	160L/B5	180M/B5	180L/B5	200L/B5	225S/B5	225M/B5
k	872	892	951	989	1136	1180	1193	1231	1303	1374	1399
k1	1007	1027	1096	1134	1306	1350	1363	1401	1503	-	-
n	194	218	258	258	310	310	348	348	390	433	433
n1	135	146	168	168	225	225	241	241	275	285	285

\* "k1" Ölçüsü frenli redüktörlere aittir.  
Dimension "k1" is for motors with brake.  
Maße "k1" ist für Bremsenmotoren.

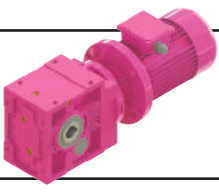

# Ölçü Sayfaları Dimension Pages Abmessungsseiten



-Mil ucu çektirme deliği DIN 332 sayfa 2 / Tapped center hole to DIN 332, sheet 2 / Zentrierung mit gewinde DIN 332, Blatt 2

## KV674.00

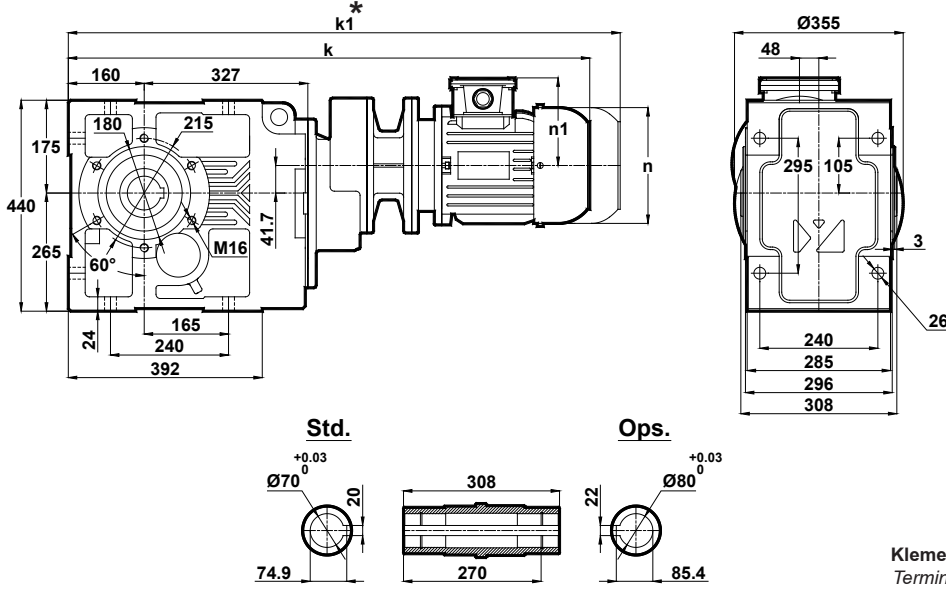

Klemens Pozisyonları  
Terminal Box Positions  
Klemmenkasten Positionen

	80/B5	90S/B5	90L/B5	100L/B5
k	885	905	930	980
k1	1005	1030	1055	1115
n	156	176	176	194
n1	118	126	126	135

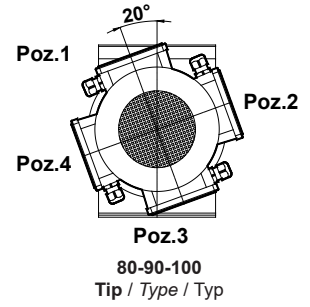

## KV674.01

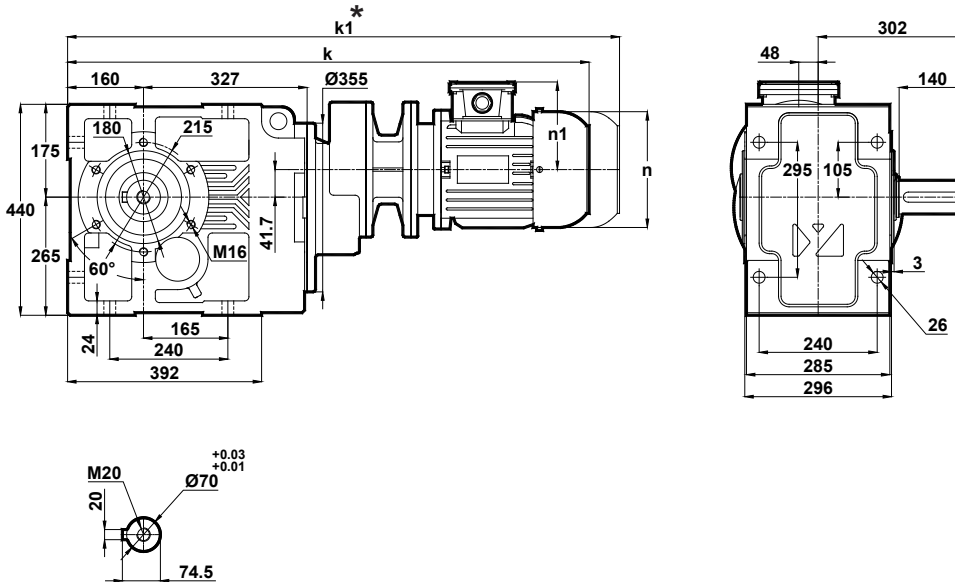

	80/B5	90S/B5	90L/B5	100L/B5
k	885	905	930	980
k1	1005	1030	1055	1115
n	156	176	176	194
n1	118	126	126	135

\* "k1" Ölçüsü frenli redüktörlere aittir.  
Dimension "k1" is for motors with brake.  
Maße "k1" ist für Bremsenmotoren.

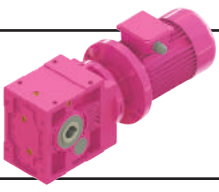

# Ölçü Sayfaları Dimension Pages Abmessungenseiten

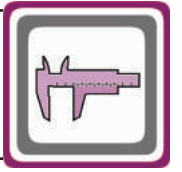

-Mil ucu çektirme deliği DIN 332 sayfa 2 / Tapped center hole to DIN 332, sheet 2 / Zentrierung mit gewinde DIN 332, Blatt 2

## KV674.02

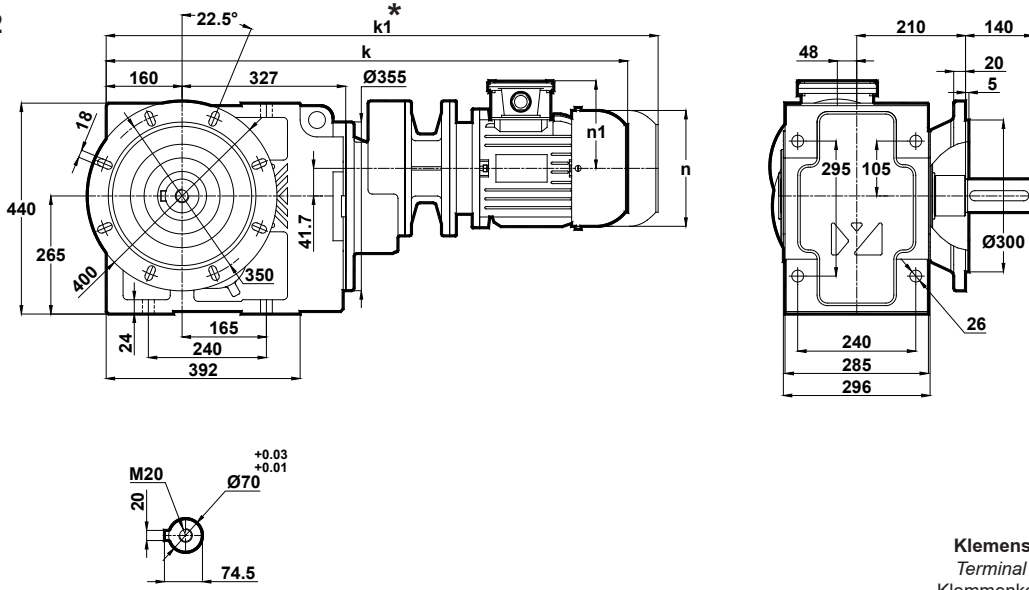

	80/B5	90S/B5	90L/B5	100L/B5
k	885	905	930	980
k1	1005	1030	1055	1115
n	156	176	176	194
n1	118	126	126	135

Klemens Pozisyonları  
Terminal Box Positions  
Klemmenkasten Positionen

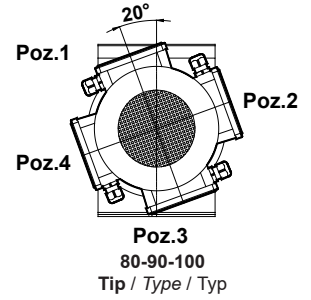

## KV674.03

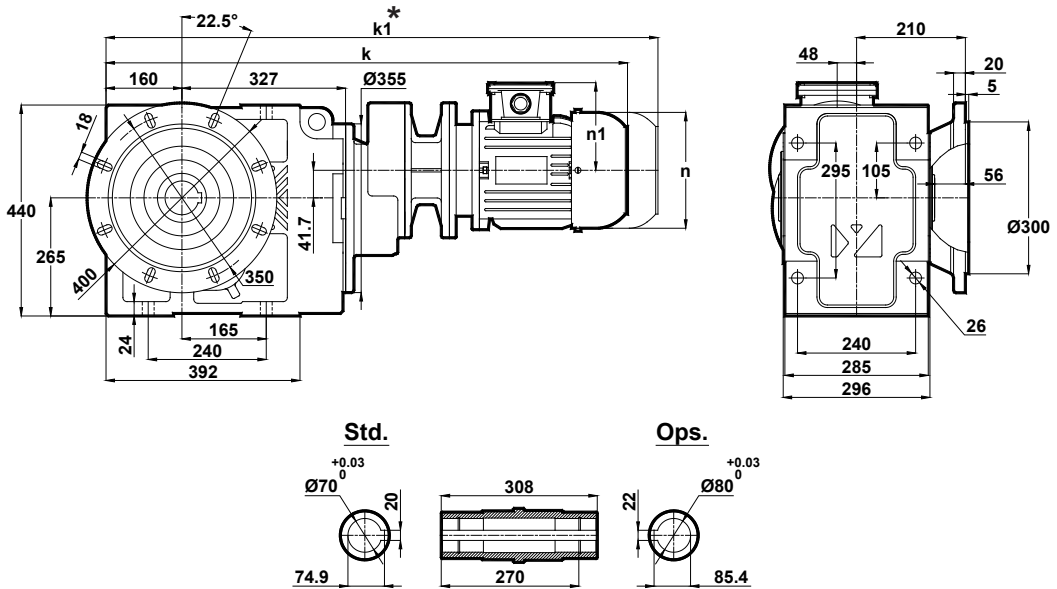

	80/B5	90S/B5	90L/B5	100L/B5
k	885	905	930	980
k1	1005	1030	1055	1115
n	156	176	176	194
n1	118	126	126	135

\* " k1 " Ölçüsü frenli redüktörlere aittir.  
Dimension " k1 " is for motors with brake.  
Maße " k1 " ist für Bremsenmotoren.

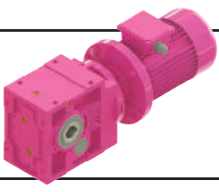

# Ölçü Sayfaları

## Dimension Pages

### Abmessungsseiten



-Mil ucu çekirme deliği DIN 332 sayfa 2 / Tapped center hole to DIN 332, sheet 2 / Zentrierung mit gewinde DIN 332, Blatt 2

#### KV674.04

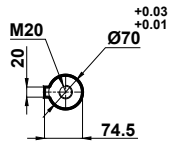
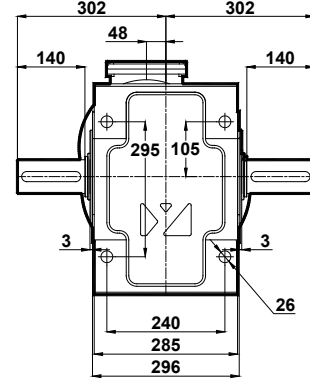
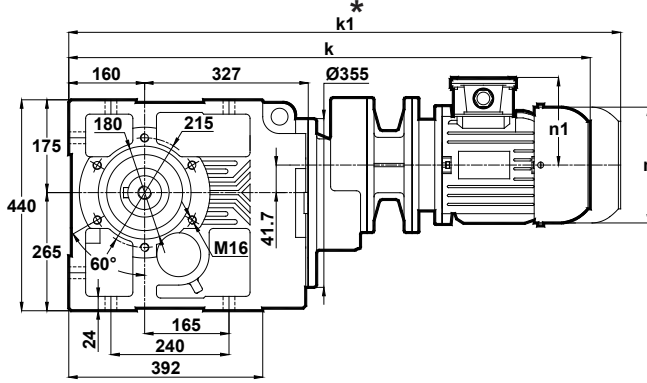

Klemens Pozisyonları  
Terminal Box Positions  
Klemmenkasten Positionen

	80/B5	90S/B5	90L/B5	100L/B5
k	885	905	930	980
k1	1005	1030	1055	1115
n	156	176	176	194
n1	118	126	126	135

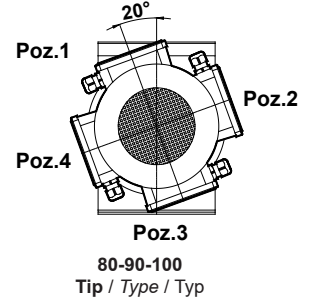

#### KV674.05

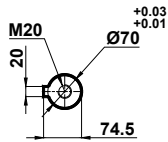
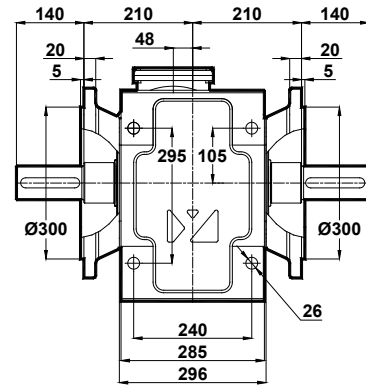
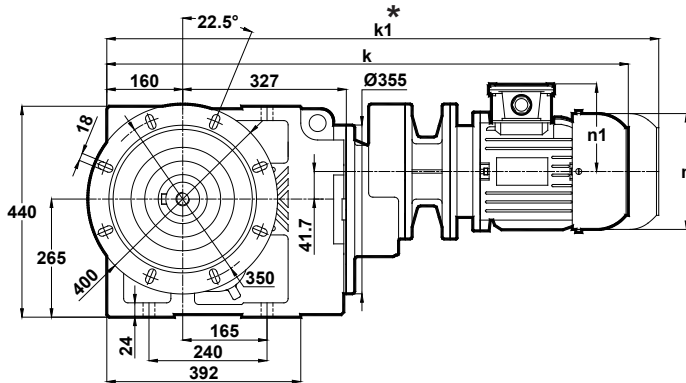

	80/B5	90S/B5	90L/B5	100L/B5
k	885	905	930	980
k1	1005	1030	1055	1115
n	156	176	176	194
n1	118	126	126	135

\* "k1" Ölçüsü frenli redüktörlere aittir.  
Dimension "k1" is for motors with brake.  
Maße "k1" ist für Bremsmotoren.

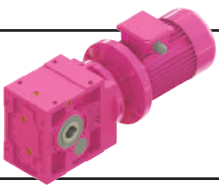

# Ölçü Sayfaları Dimension Pages Abmessungsseiten

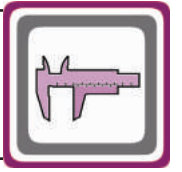

-Mil ucu çekirme deliği DIN 332 sayfa 2 / Tapped center hole to DIN 332, sheet 2 / Zentrierung mit gewinde DIN 332, Blatt 2

KV674.08

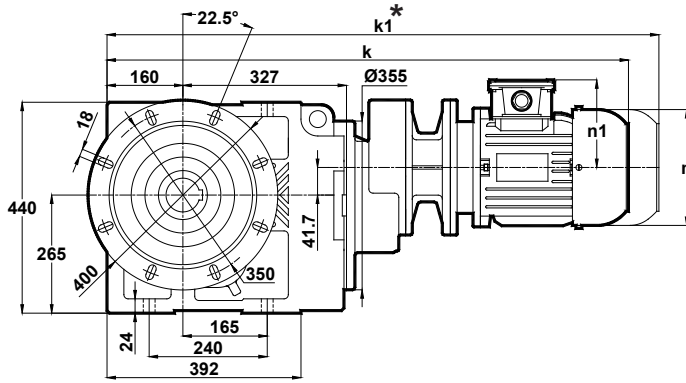

**Std.**

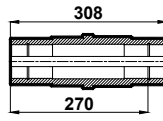
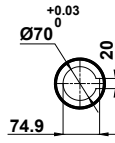

**Ops.**

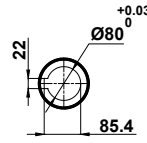

**Klemens Pozisyonları**  
Terminal Box Positions  
Klemmenkasten Positionen

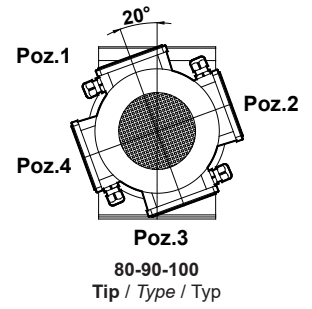

	80/B5	90S/B5	90L/B5	100L/B5
<b>k</b>	885	905	930	980
<b>k1</b>	1005	1030	1055	1115
<b>n</b>	156	176	176	194
<b>n1</b>	118	126	126	135

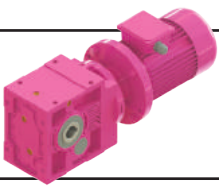

# Ölçü Sayfaları Dimension Pages Abmessungsseiten



-Mil ucu çektirme deliği DIN 332 sayfa 2 / Tapped center hole to DIN 332, sheet 2 / Zentrierung mit gewinde DIN 332, Blatt 2

KV675.00  
KV676.00

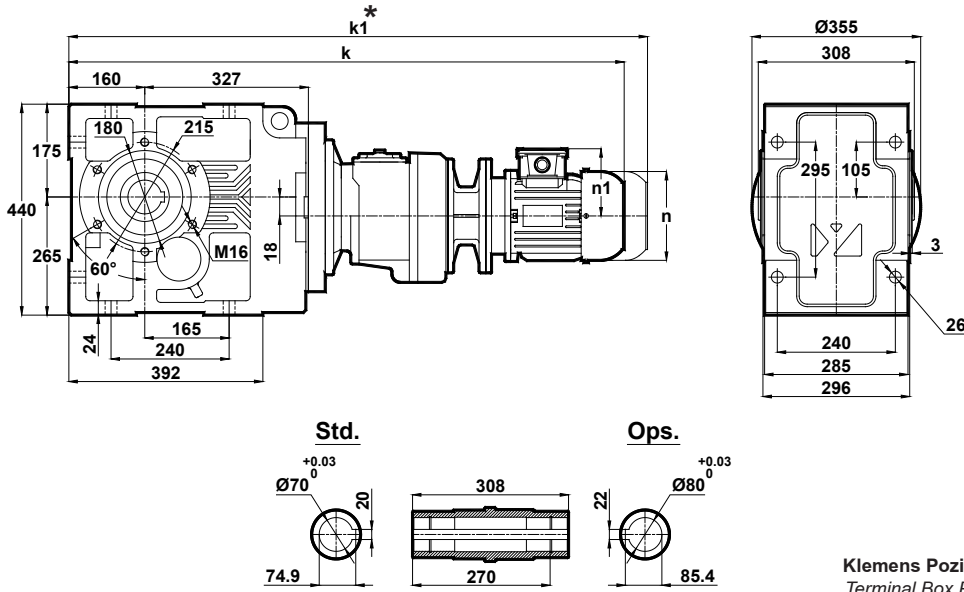

	71/B5	80/B5	90S/B5	90L/B5
k	1016	1036	1056	1081
k1	1136	1156	1181	1206
n	138	156	176	176
n1	110	118	126	126

Klemens Pozisyonları  
Terminal Box Positions  
Klemmenkasten Positionen  
**Poz.1**

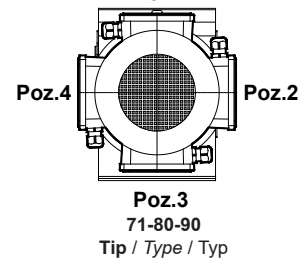

KV675.01  
KV676.01

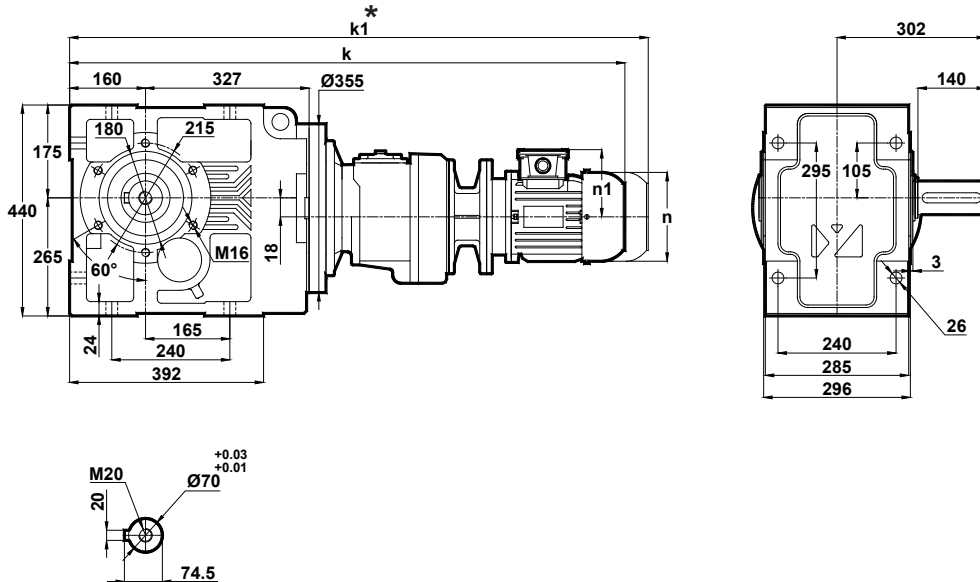

	71/B5	80/B5	90S/B5	90L/B5
k	1016	1036	1056	1081
k1	1136	1156	1181	1206
n	138	156	176	176
n1	110	118	126	126

\* " k1 " Ölçüsü frenli redüktörlere aittir.  
Dimension " k1 " is for motors with brake.  
Maße " k1 " ist für Bremsenmotoren.

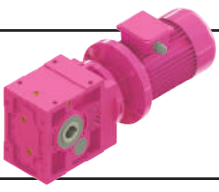

# Ölçü Sayfaları Dimension Pages Abmessungsseiten

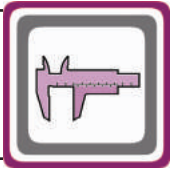

-Mil ucu çekirme deliği DIN 332 sayfa 2 / Tapped center hole to DIN 332, sheet 2 / Zentrierung mit gewinde DIN 332, Blatt 2

KV675.02  
KV676.02

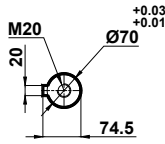
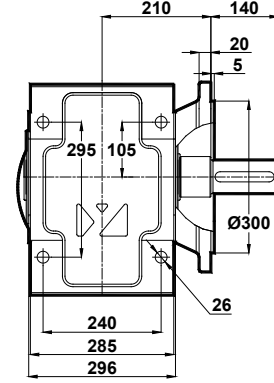
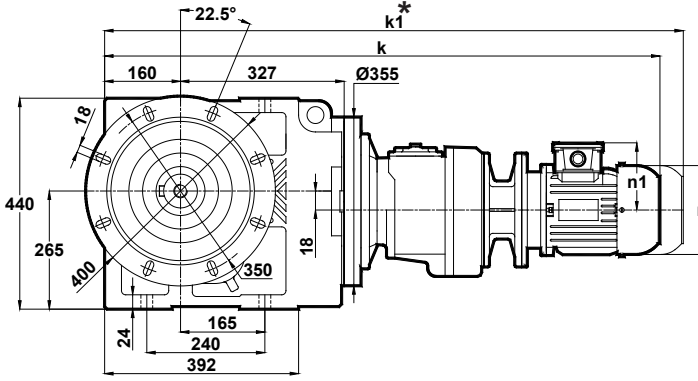

Klemens Pozisyonları  
Terminal Box Positions  
Klemmenkasten Positionen

	71/B5	80/B5	90S/B5	90L/B5
k	1016	1036	1056	1081
k1	1136	1156	1181	1206
n	138	156	176	176
n1	110	118	126	126

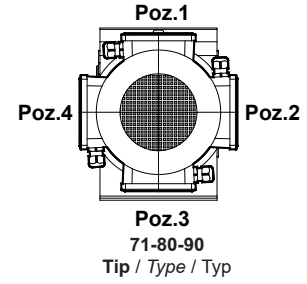

KV675.03  
KV676.03

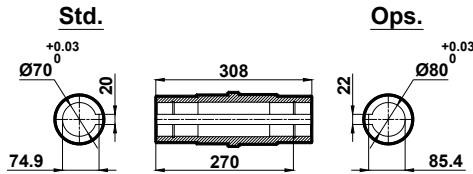
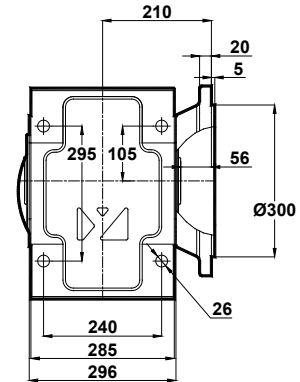
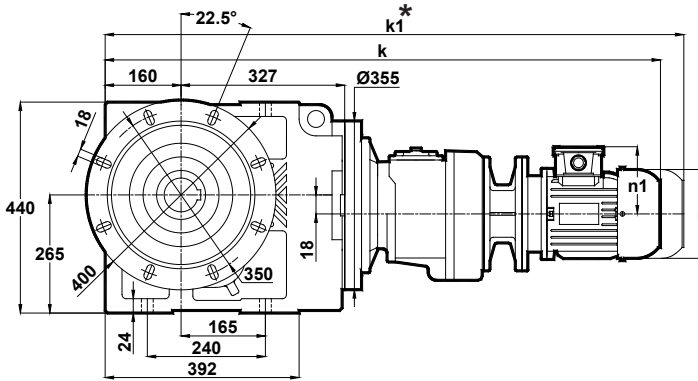

	71/B5	80/B5	90S/B5	90L/B5
k	1016	1036	1056	1081
k1	1136	1156	1181	1206
n	138	156	176	176
n1	110	118	126	126

\* " k1 " Ölçüsü frenli redüktörlere aittir.  
Dimension " k1 " is for motors with brake.  
Maße " k1 " ist für Bremsenmotoren.

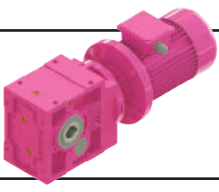

# Ölçü Sayfaları Dimension Pages Abmessungsseiten



-Mil ucu çektirme deliği DIN 332 sayfa 2 / Tapped center hole to DIN 332, sheet 2 / Zentrierung mit gewinde DIN 332, Blatt 2

KV675.04  
KV676.04

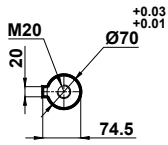
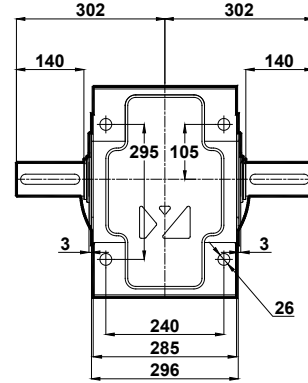
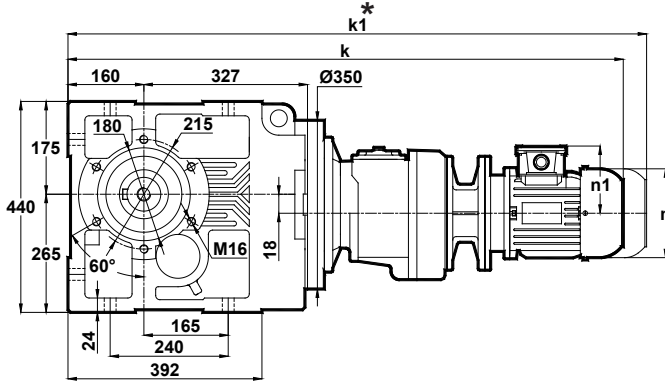

	71/B5	80/B5	90S/B5	90L/B5
k	1016	1036	1056	1081
k1	1136	1156	1181	1206
n	138	156	176	176
n1	110	118	126	126

Klemens Pozisyonları  
Terminal Box Positions  
Klemmenkasten Positionen

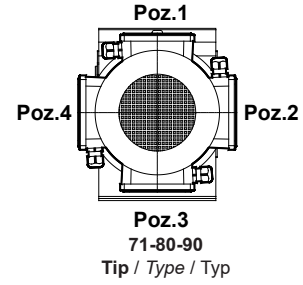

KV675.05  
KV676.05

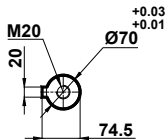
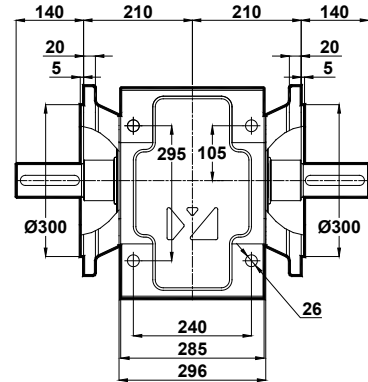
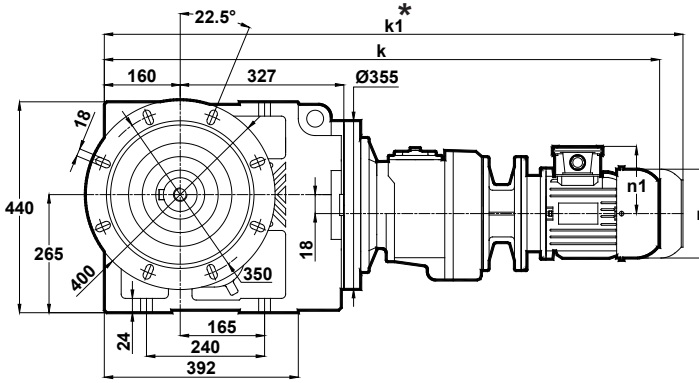

	71/B5	80/B5	90S/B5	90L/B5
k	1016	1036	1056	1081
k1	1136	1156	1181	1206
n	138	156	176	176
n1	110	118	126	126

\* "k1" Ölçüsü frenli redüktörlere aittir.  
Dimension "k1" is for motors with brake.  
Maße "k1" ist für Bremsenmotoren.

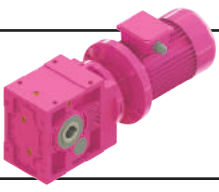

# Ölçü Sayfaları Dimension Pages Abmessungsseiten

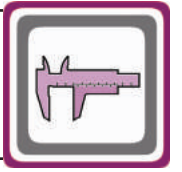

-Mil ucu çektirme deliği DIN 332 sayfa 2 / Tapped center hole to DIN 332, sheet 2 / Zentrierung mit gewinde DIN 332, Blatt 2

KV675.08  
KV676.08

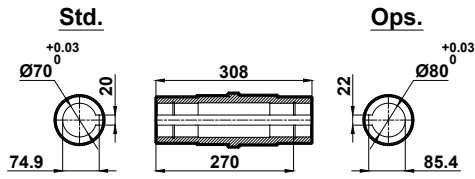
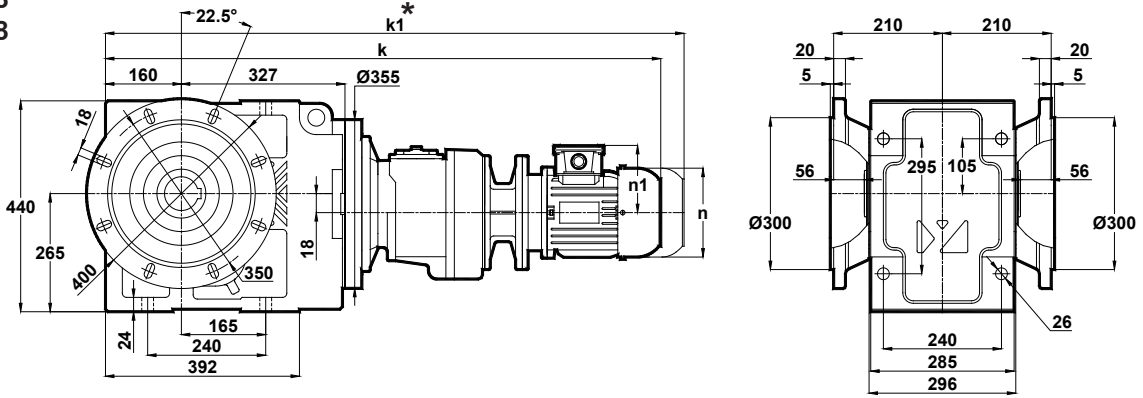

	71/B5	80/B5	90S/B5	90L/B5
k	1016	1036	1056	1081
k1	1136	1156	1181	1206
n	138	156	176	176
n1	110	118	126	126

Klemens Pozisyonları  
Terminal Box Positions  
Klemmenkasten Positionen

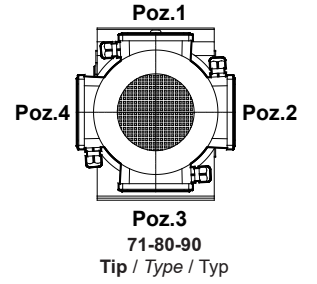

\* "k1" Ölçüsü frenli redüktörlere aittir.  
Dimension "k1" is for motors with brake.  
Maße "k1" ist für Bremsenmotoren.

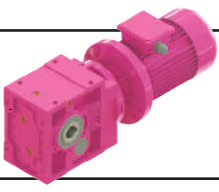

# Ölçü Sayfaları Dimension Pages Abmessungsseiten



-Mil ucu çekirme deliği DIN 332 sayfa 2 / Tapped center hole to DIN 332, sheet 2 / Zentrierung mit gewinde DIN 332, Blatt 2

## KV773.00

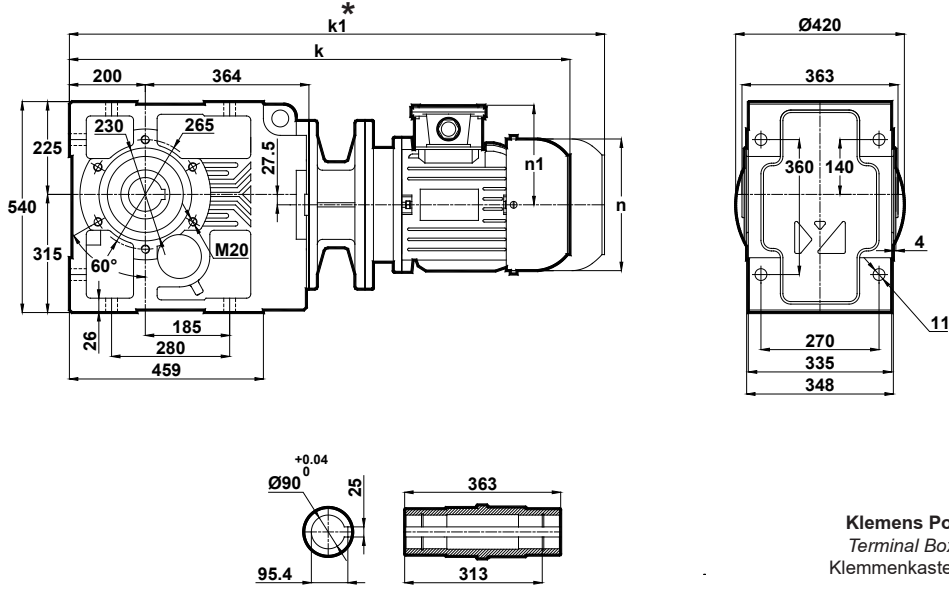

Klemens Pozisyonları  
Terminal Box Positions  
Klemmenkasten Positionen

	132S/B5	132M/B5	160M/B5	160L/B5	180M/B5	180L/B5	200L/B5	225S/B5	225M/B5	250M/B5
k	1028	1066	1207	1251	1264	1302	1376	1447	1472	1548
k1	1173	1211	1377	1421	1434	1472	1576	-	-	-
n	258	258	310	310	348	348	390	433	433	480
n1	168	168	225	225	241	241	275	285	285	322

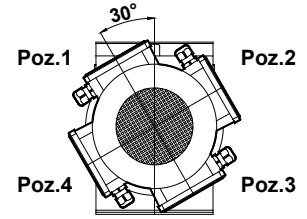

132-160-180-200-225-250  
Tip / Type / Typ

## KV773.01

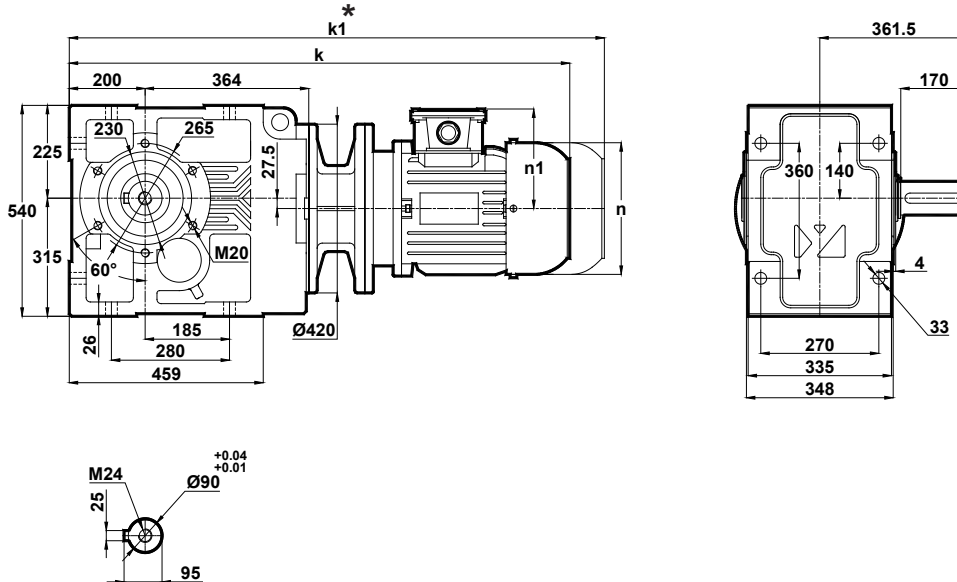

	132S/B5	132M/B5	160M/B5	160L/B5	180M/B5	180L/B5	200L/B5	225S/B5	225M/B5	250M/B5
k	1028	1066	1207	1251	1264	1302	1376	1447	1472	1548
k1	1173	1211	1377	1421	1434	1472	1576	-	-	-
n	258	258	310	310	348	348	390	433	433	480
n1	168	168	225	225	241	241	275	285	285	322

\* "k1" Ölçüsü frenli redüktörlere aittir.  
Dimension "k1" is for motors with brake.  
Maße "k1" ist für Bremsenmotoren.

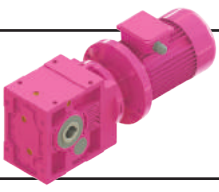

# Ölçü Sayfaları

## Dimension Pages

### Abmessungsseiten

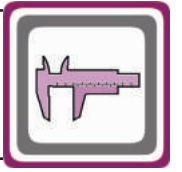

-Mil ucu çekirme deliği DIN 332 sayfa 2 / Tapped center hole to DIN 332, sheet 2 / Zentrierung mit gewinde DIN 332, Blatt 2

#### KV773.02

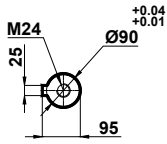
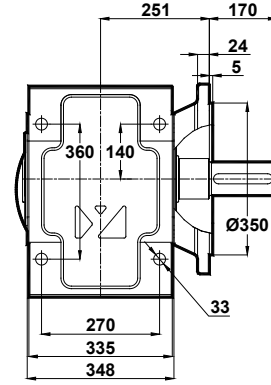
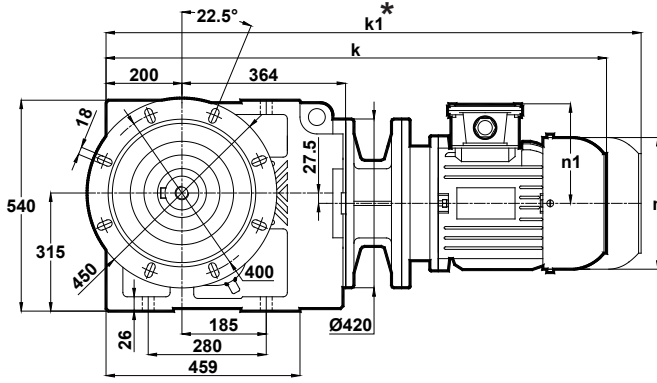

Klemens Pozisyonları  
Terminal Box Positions  
Klemmenkasten Positionen

	132S/B5	132M/B5	160M/B5	160L/B5	180M/B5	180L/B5	200L/B5	225S/B5	225M/B5	250M/B5
k	1028	1066	1207	1251	1264	1302	1376	1447	1472	1548
k1	1173	1211	1377	1421	1434	1472	1576	-	-	-
n	258	258	310	310	348	348	390	433	433	480
n1	168	168	225	225	241	241	275	285	285	322

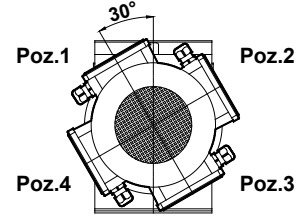

132-160-180-200-225-250  
Tip / Type / Typ

#### KV773.03

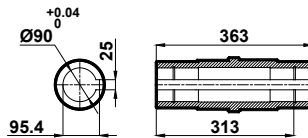
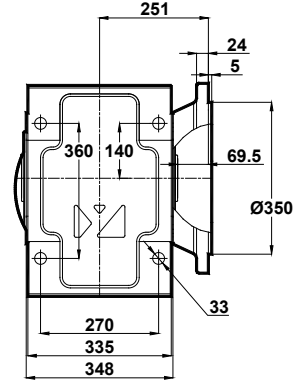
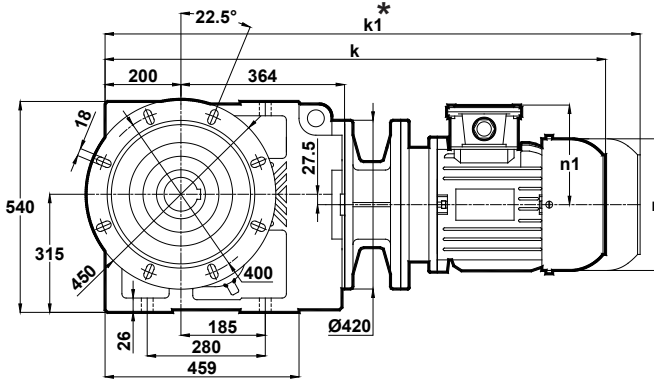

	132S/B5	132M/B5	160M/B5	160L/B5	180M/B5	180L/B5	200L/B5	225S/B5	225M/B5	250M/B5
k	1028	1066	1207	1251	1264	1302	1376	1447	1472	1548
k1	1173	1211	1377	1421	1434	1472	1576	-	-	-
n	258	258	310	310	348	348	390	433	433	480
n1	168	168	225	225	241	241	275	285	285	322

\* " k1 " Ölçüsü frenli redüktörlere aittir.  
Dimension " k1 " is for motors with brake.  
Maße " k1 " ist für Bremsenmotoren.

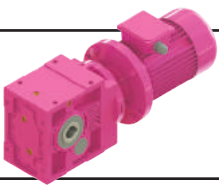

# Ölçü Sayfaları Dimension Pages Abmessungsseiten



-Mil ucu çektirme deliği DIN 332 sayfa 2 / Tapped center hole to DIN 332, sheet 2 / Zentrierung mit gewinde DIN 332, Blatt 2

## KV773.04

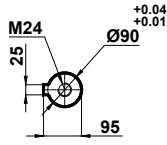
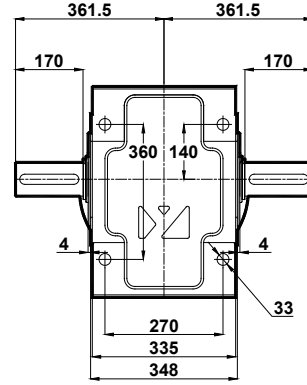
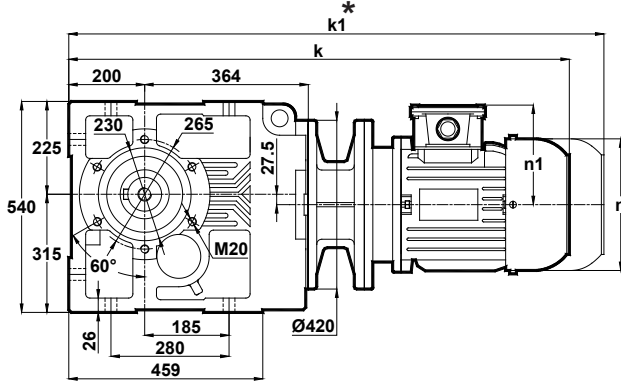

Klemens Pozisyonları  
Terminal Box Positions  
Klemmenkasten Positionen

	132S/B5	132M/B5	160M/B5	160L/B5	180M/B5	180L/B5	200L/B5	225S/B5	225M/B5	250M/B5
k	1028	1066	1207	1251	1264	1302	1376	1447	1472	1548
k1	1173	1211	1377	1421	1434	1472	1576	-	-	-
n	258	258	310	310	348	348	390	433	433	480
n1	168	168	225	225	241	241	275	285	285	322

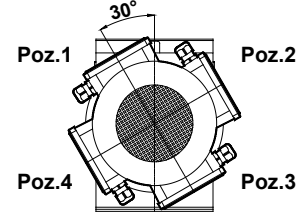

132-160-180-200-225-250  
Tip / Type / Typ

## KV773.05

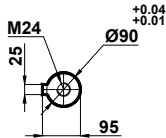
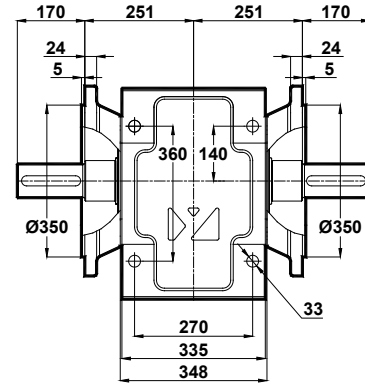
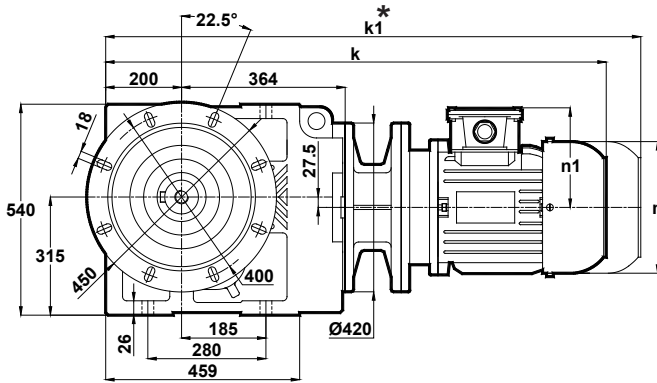

	132S/B5	132M/B5	160M/B5	160L/B5	180M/B5	180L/B5	200L/B5	225S/B5	225M/B5	250M/B5
k	1028	1066	1207	1251	1264	1302	1376	1447	1472	1548
k1	1173	1211	1377	1421	1434	1472	1576	-	-	-
n	258	258	310	310	348	348	390	433	433	480
n1	168	168	225	225	241	241	275	285	285	322

\* "k1" Ölçüsü frenli redüktörlere aittir.  
Dimension "k1" is for motors with brake.  
Maße "k1" ist für Bremsenmotoren.

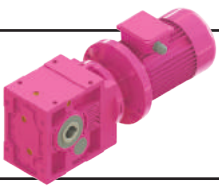

# Ölçü Sayfaları Dimension Pages Abmessungsseiten

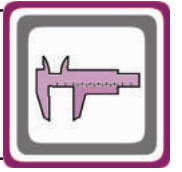

-Mil ucu çekirme deliği DIN 332 sayfa 2 / Tapped center hole to DIN 332, sheet 2 / Zentrierung mit gewinde DIN 332, Blatt 2

KV773.08

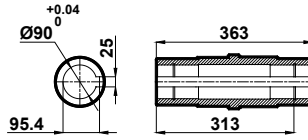
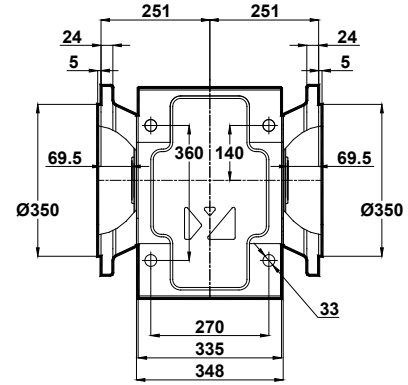
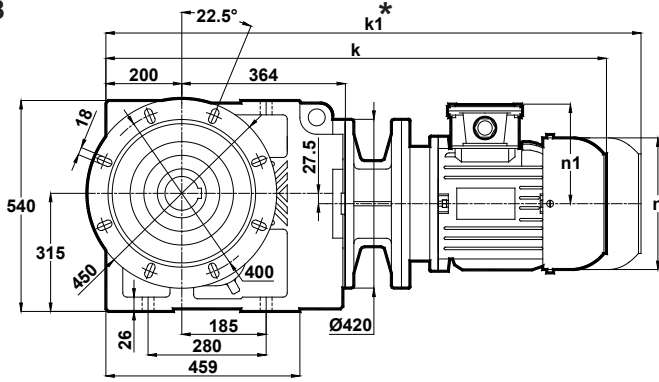

Klemens Pozisyonları  
Terminal Box Positions  
Klemmenkasten Positionen

	132S/B5	132M/B5	160M/B5	160L/B5	180M/B5	180L/B5	200L/B5	225S/B5	225M/B5	250M/B5
k	1028	1066	1207	1251	1264	1302	1376	1447	1472	1548
k1	1173	1211	1377	1421	1434	1472	1576	-	-	-
n	258	258	310	310	348	348	390	433	433	480
n1	168	168	225	225	241	241	275	285	285	322

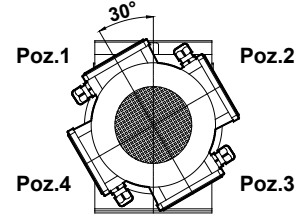

132-160-180-200-225-250  
Tip / Type / Typ

\* "k1" Ölçüsü frenli redüktörlere aittir.  
Dimension "k1" is for motors with brake.  
Maße "k1" ist für Bremsenmotoren.

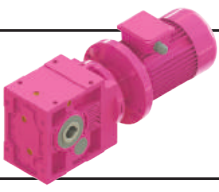

# Ölçü Sayfaları Dimension Pages Abmessungenseiten



-Mil ucu çektirme deliği DIN 332 sayfa 2 / Tapped center hole to DIN 332, sheet 2 / Zentrierung mit gewinde DIN 332, Blatt 2

KV774.00

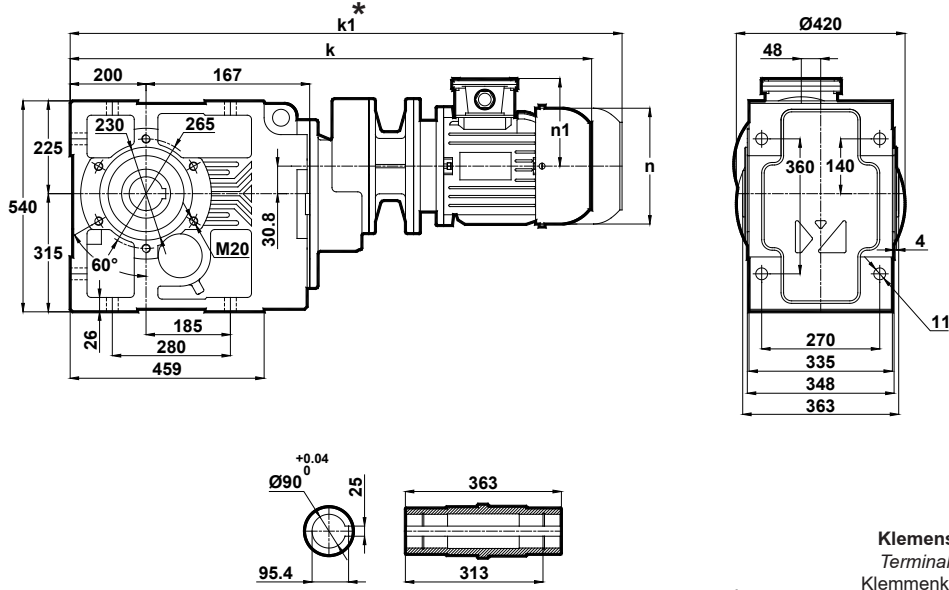

Klemens Pozisyonları  
Terminal Box Positions  
Klemmenkasten Positionen

	90S/B5	90L/B5	100L/B5	112M/B5	132S/B5	132M/B5
k	982	1007	1057	1077	1140	1178
k1	1107	1132	1192	1212	1285	1323
n	176	176	194	218	258	258
n1	126	126	135	146	168	168

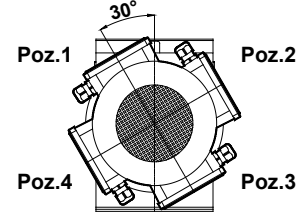

90-100-112-132  
Tip / Type / Typ

KV774.01

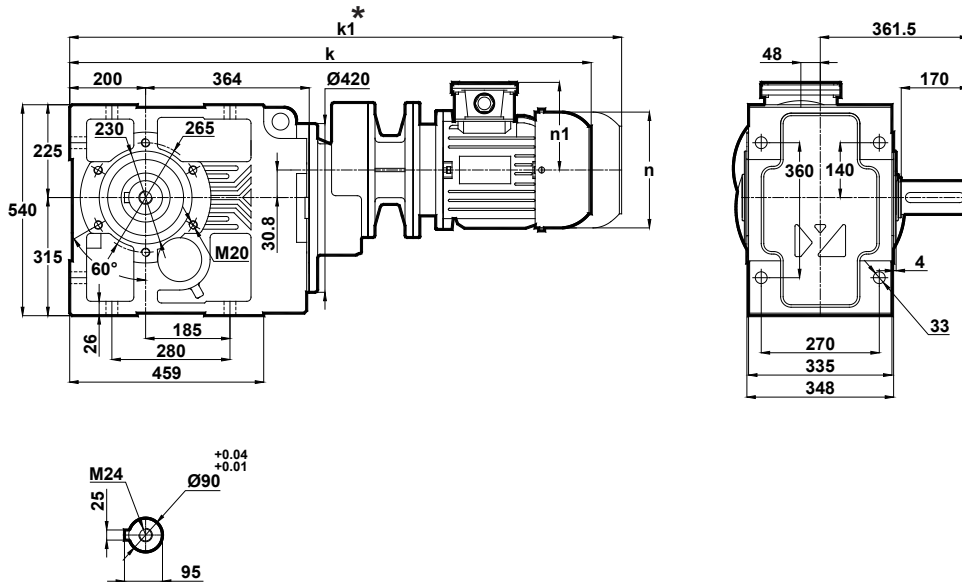

	90S/B5	90L/B5	100L/B5	112M/B5	132S/B5	132M/B5
k	982	1007	1057	1077	1140	1178
k1	1107	1132	1192	1212	1285	1323
n	176	176	194	218	258	258
n1	126	126	135	146	168	168

\* " k1 " Ölçüsü frenli redüktörlere aittir.  
Dimension " k1 " is for motors with brake.  
Maße " k1 " ist für Bremsenmotoren.

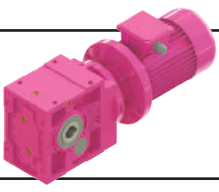

# Ölçü Sayfaları Dimension Pages Abmessungenseiten

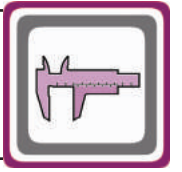

-Mil ucu çektirme deliği DIN 332 sayfa 2 / Tapped center hole to DIN 332, sheet 2 / Zentrierung mit gewinde DIN 332, Blatt 2

## KV774.02

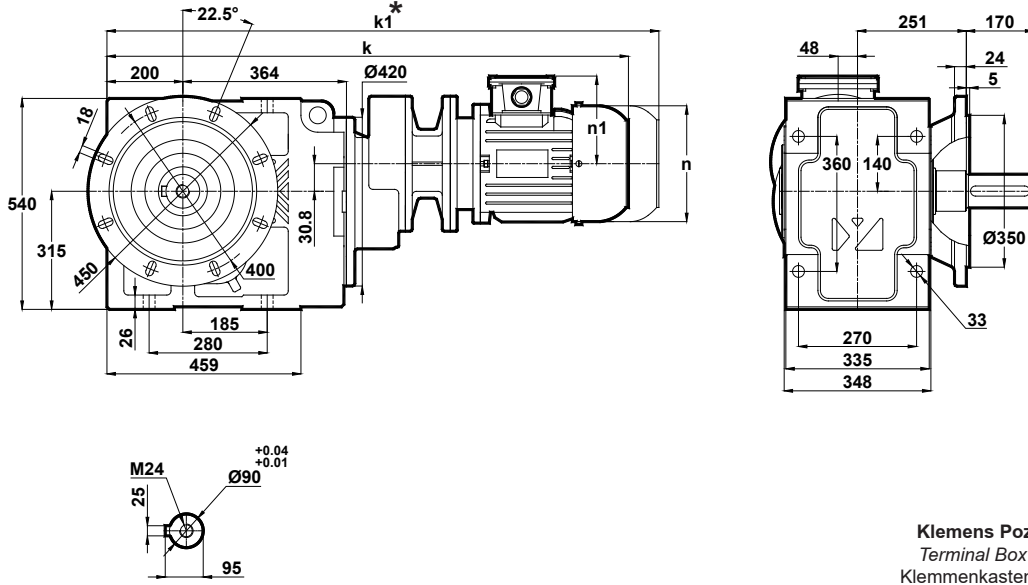

	90S/B5	90L/B5	100L/B5	112M/B5	132S/B5	132M/B5
k	982	1007	1057	1077	1140	1178
k1	1107	1132	1192	1212	1285	1323
n	176	176	194	218	258	258
n1	126	126	135	146	168	168

Klemens Pozisyonları  
Terminal Box Positions  
Klemmenkasten Positionen

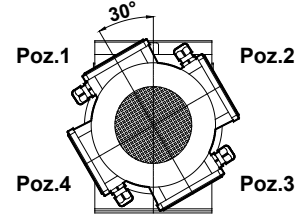

90-100-112-132  
Tip / Type / Typ

## KV774.03

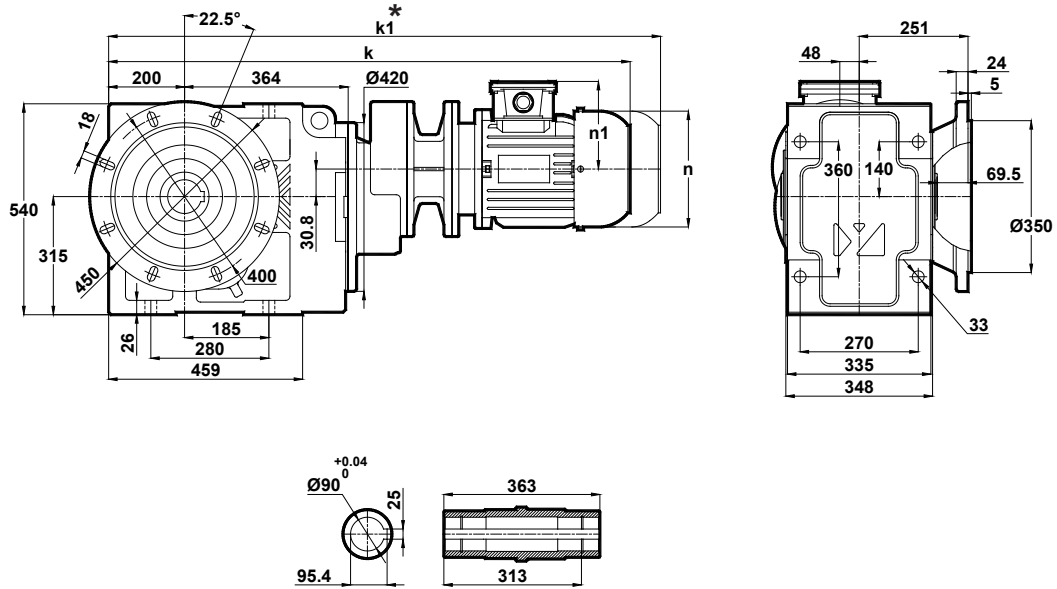

	90S/B5	90L/B5	100L/B5	112M/B5	132S/B5	132M/B5
k	982	1007	1057	1077	1140	1178
k1	1107	1132	1192	1212	1285	1323
n	176	176	194	218	258	258
n1	126	126	135	146	168	168

\* " k1 " Ölçüsü frenli redüktörlere aittir.  
Dimension " k1 " is for motors with brake.  
Maße " k1 " ist für Bremsenmotoren.

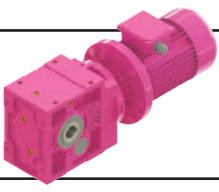

# Ölçü Sayfaları Dimension Pages Abmessungsseiten



-Mil ucu çekirme deliği DIN 332 sayfa 2 / Tapped center hole to DIN 332, sheet 2 / Zentrierung mit gewinde DIN 332, Blatt 2

KV774.04

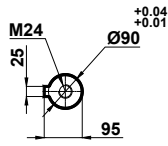
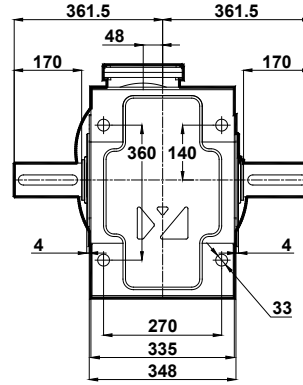
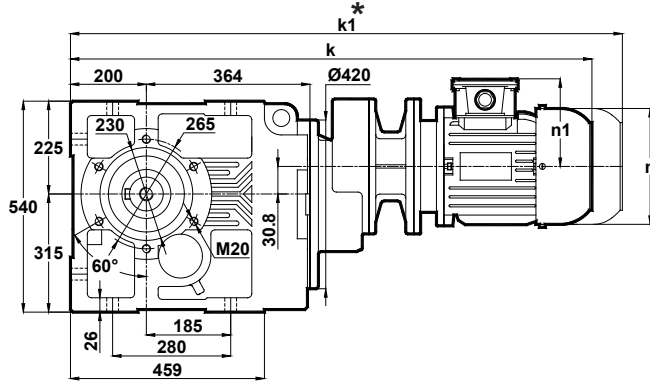

Klemens Pozisyonları  
Terminal Box Positions  
Klemmenkasten Positionen

	90S/B5	90L/B5	100L/B5	112M/B5	132S/B5	132M/B5
k	982	1007	1057	1077	1140	1178
k1	1107	1132	1192	1212	1285	1323
n	176	176	194	218	258	258
n1	126	126	135	146	168	168

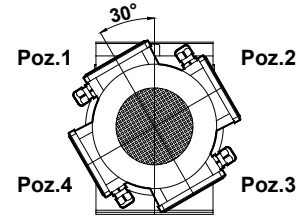

90-100-112-132  
T10 / T10e / T10v

KV774.05

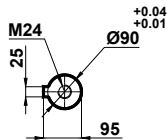
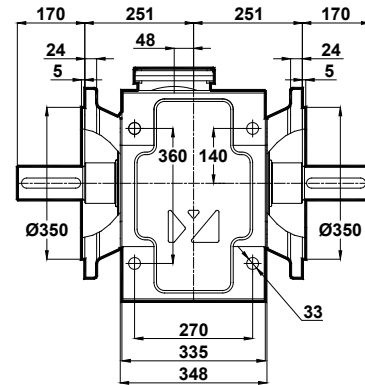
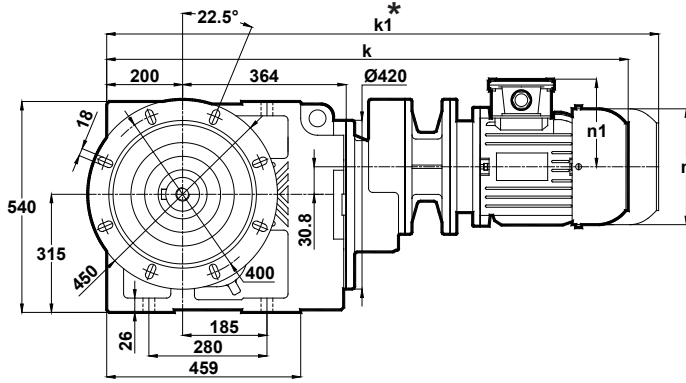

	90S/B5	90L/B5	100L/B5	112M/B5	132S/B5	132M/B5
k	982	1007	1057	1077	1140	1178
k1	1107	1132	1192	1212	1285	1323
n	176	176	194	218	258	258
n1	126	126	135	146	168	168

\* " k1 " Ölçüsü frenli redüktörlere aittir.  
Dimension " k1 " is for motors with brake.  
Maße " k1 " ist für Bremsenmotoren.

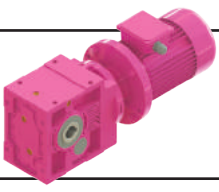

# Ölçü Sayfaları Dimension Pages Abmessungsseiten

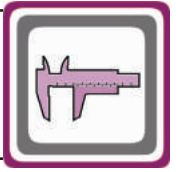

-Mil ucu çektirme deliği DIN 332 sayfa 2 / Tapped center hole to DIN 332, sheet 2 / Zentrierung mit gewinde DIN 332, Blatt 2

KV774.08

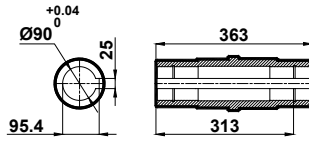
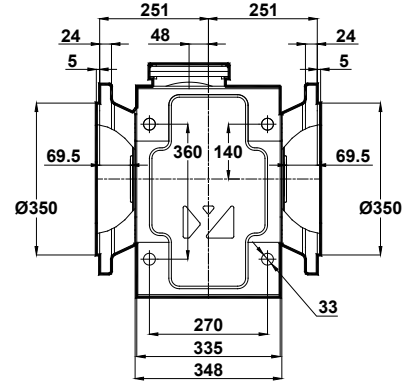
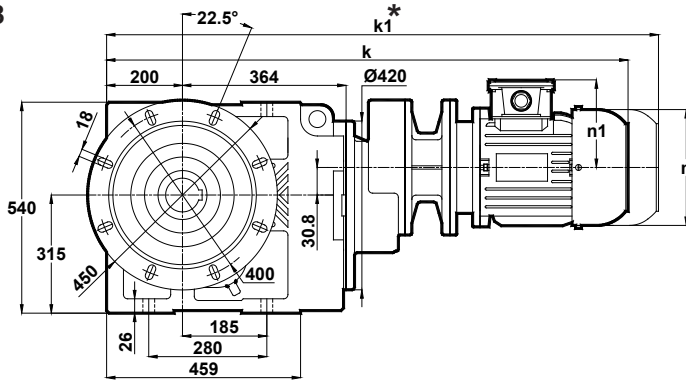

	90S/B5	90L/B5	100L/B5	112M/B5	132S/B5	132M/B5
k	982	1007	1057	1077	1140	1178
k1	1107	1132	1192	1212	1285	1323
n	176	176	194	218	258	258
n1	126	126	135	146	168	168

Klemens Pozisyonları  
Terminal Box Positions  
Klemmenkasten Positionen

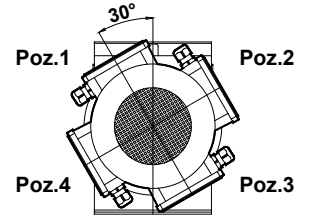

90-100-112-132  
Tip / Type / Typ

\* " k1 " Ölçüsü frenli redüktörlere aittir.  
Dimension " k1 " is for motors with brake.  
Maße " k1 " ist für Bremsenmotoren.

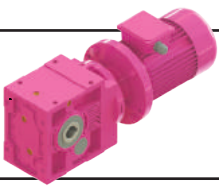

# Ölçü Sayfaları Dimension Pages Abmessungsseiten



-Mil ucu çektirme deliği DIN 332 sayfa 2 / Tapped center hole to DIN 332, sheet 2 / Zentrierung mit gewinde DIN 332, Blatt 2

KV775.00  
KV776.00

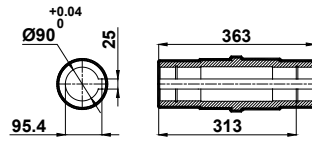
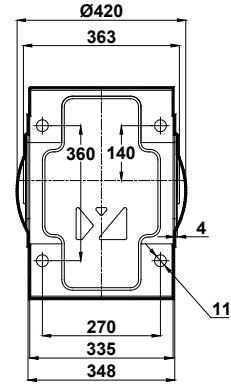
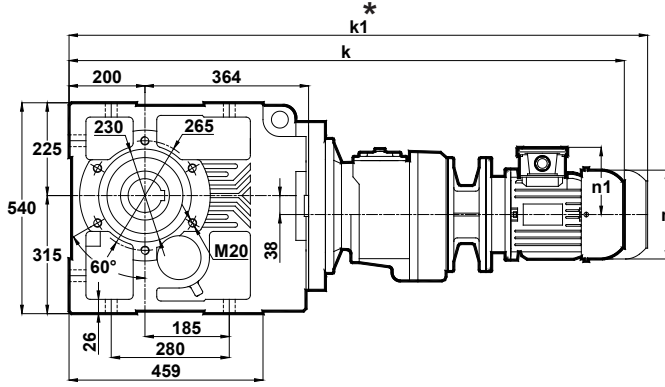

Klemens Pozisyonları  
Terminal Box Positions  
Klemmenkasten Positionen

	71/B5	80/B5	90S/B5	90L/B5	100L/B5
k	1093	1113	1133	1158	1207
k1	1213	1233	1258	1283	1342
n	138	156	176	176	194
n1	110	118	126	126	135

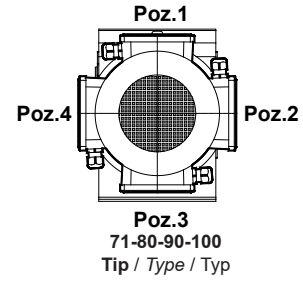

KV775.01  
KV776.01

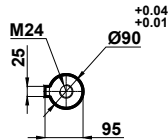
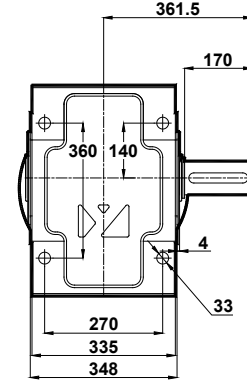
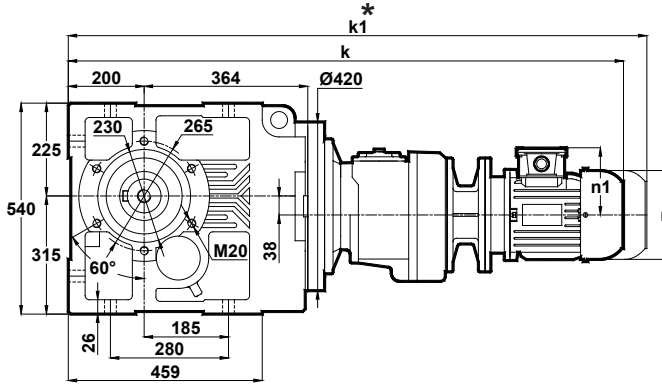

	71/B5	80/B5	90S/B5	90L/B5	100L/B5
k	1093	1113	1133	1158	1207
k1	1213	1233	1258	1283	1342
n	138	156	176	176	194
n1	110	118	126	126	135

\* " k1 " Ölçüsü frenli redüktörlere aittir.  
Dimension " k1 " is for motors with brake.  
Maße " k1 " ist für Bremsenmotoren.

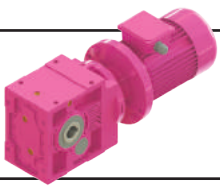

# Ölçü Sayfaları Dimension Pages Abmessungsseiten

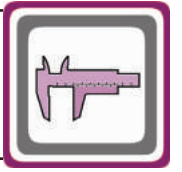

-Mil ucu çekirme deliği DIN 332 sayfa 2 / Tapped center hole to DIN 332, sheet 2 / Zentrierung mit gewinde DIN 332, Blatt 2

KV775.02  
KV776.02

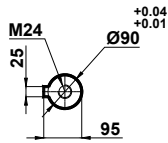
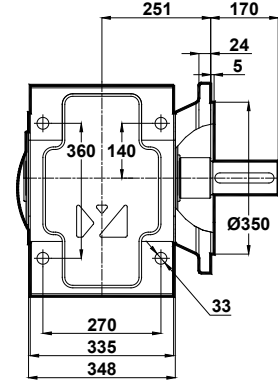
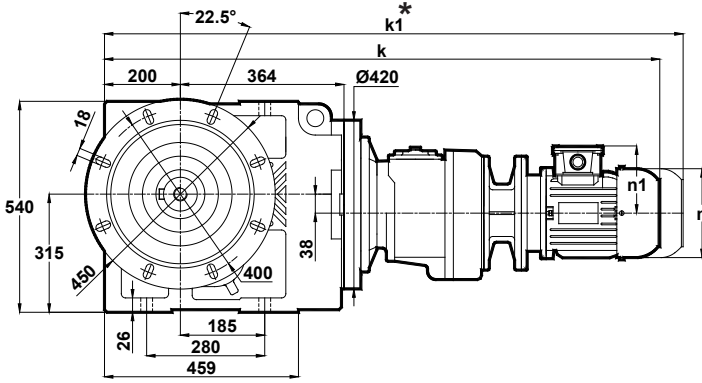

Klemens Pozisyonları  
Terminal Box Positions  
Klemmenkasten Positionen

	71/B5	80/B5	90S/B5	90L/B5	100L/B5
k	1093	1113	1133	1158	1207
k1	1213	1233	1258	1283	1342
n	138	156	176	176	194
n1	110	118	126	126	135

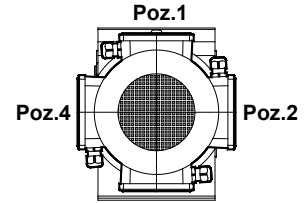

Poz.3  
71-80-90-100  
Tip / Type / Typ

KV775.03  
KV776.03

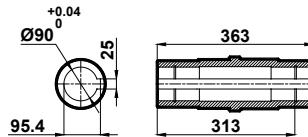
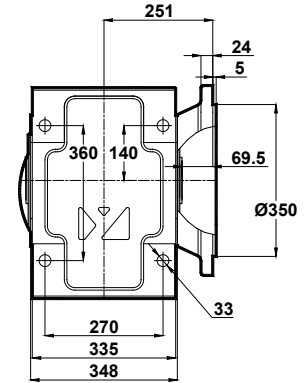
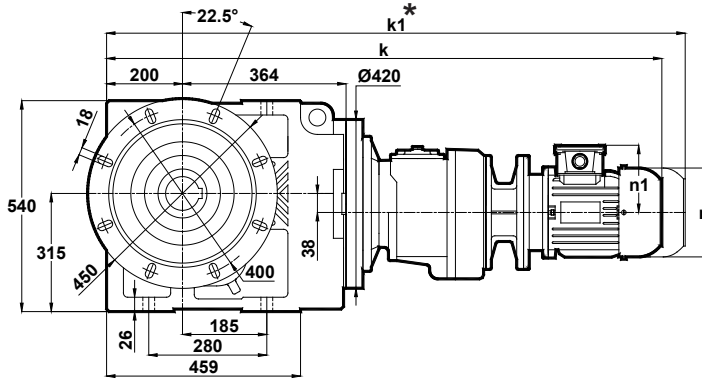

	71/B5	80/B5	90S/B5	90L/B5	100L/B5
k	1093	1113	1133	1158	1207
k1	1213	1233	1258	1283	1342
n	138	156	176	176	194
n1	110	118	126	126	135

\* " k1 " Ölçüsü frenli redüktörlere aittir.  
Dimension " k1 " is for motors with brake.  
Maße " k1 " ist für Bremsenmotoren.

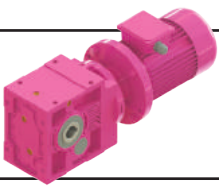

# Ölçü Sayfaları Dimension Pages Abmessungsseiten



-Mil ucu çektirme deliği DIN 332 sayfa 2 / Tapped center hole to DIN 332, sheet 2 / Zentrierung mit gewinde DIN 332, Blatt 2

KV775.04  
KV776.04

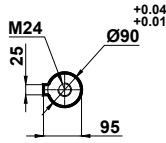
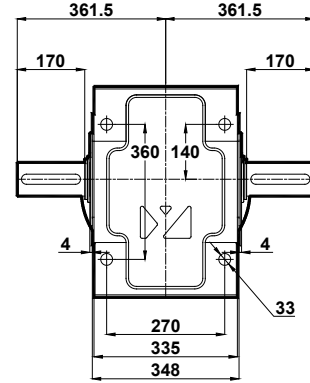
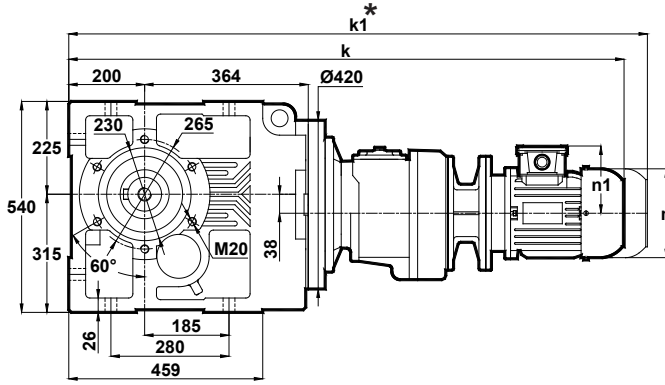

	71/B5	80/B5	90S/B5	90L/B5	100L/B5
k	1093	1113	1133	1158	1207
k1	1213	1233	1258	1283	1342
n	138	156	176	176	194
n1	110	118	126	126	135

Klemens Pozisyonları  
Terminal Box Positions  
Klemmenkasten Positionen

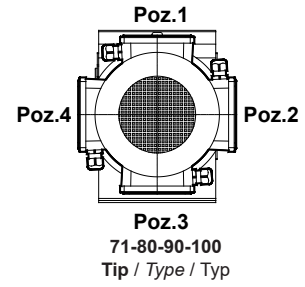

KV775.05  
KV776.05

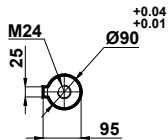
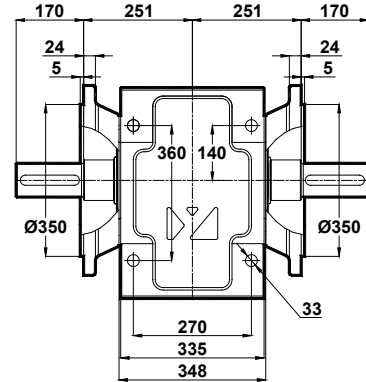
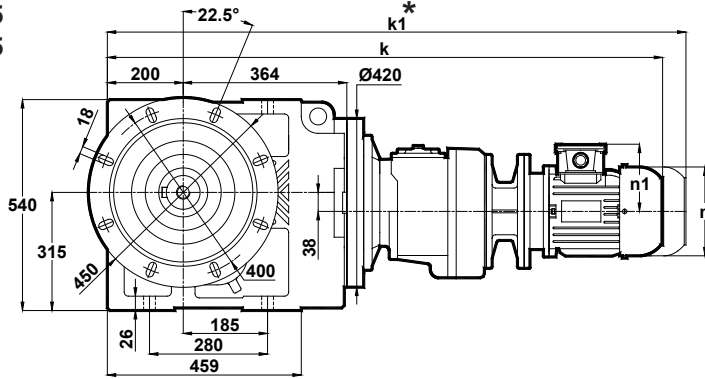

	71/B5	80/B5	90S/B5	90L/B5	100L/B5
k	1093	1113	1133	1158	1207
k1	1213	1233	1258	1283	1342
n	138	156	176	176	194
n1	110	118	126	126	135

\* " k1 " Ölçüsü frenli redüktörlere aittir.  
Dimension " k1 " is for motors with brake.  
Maße " k1 " ist für Bremsmotoren.

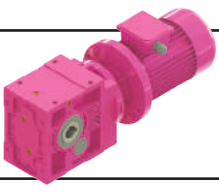

# Ölçü Sayfaları Dimension Pages Abmessungenseiten

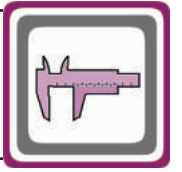

-Mil ucu çektirme deliği DIN 332 sayfa 2 / Tapped center hole to DIN 332, sheet 2 / Zentrierung mit gewinde DIN 332, Blatt 2

KV775.08  
KV776.08

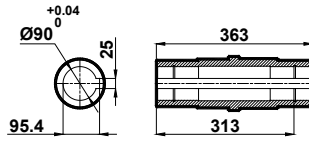
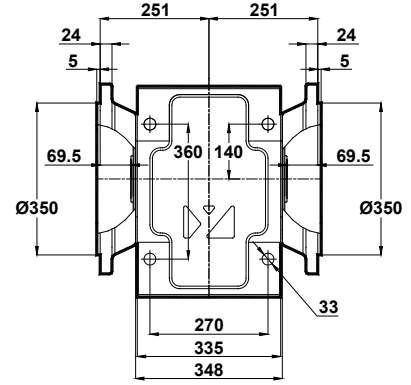
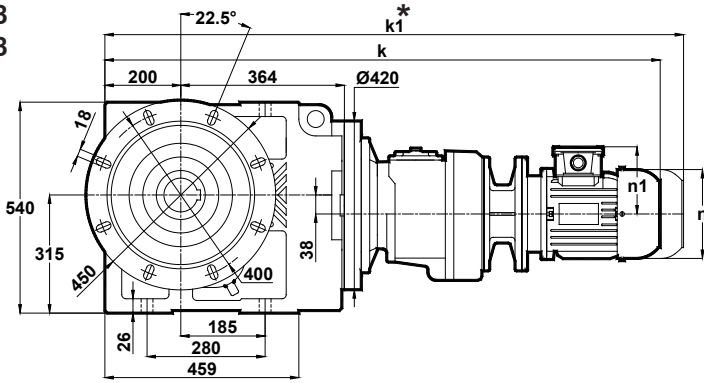

Klemens Pozisyonları  
Terminal Box Positions  
Klemmenkasten Positionen

	71/B5	80/B5	90S/B5	90L/B5	100L/B5
k	1093	1113	1133	1158	1207
k1	1213	1233	1258	1283	1342
n	138	156	176	176	194
n1	110	118	126	126	135

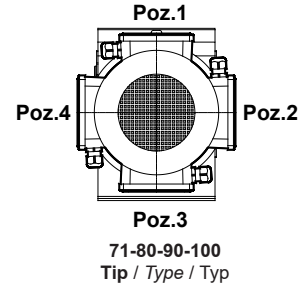

\* " k1 " Ölçüsü frenli redüktörlere aittir.  
Dimension " k1 " is for motors with brake.  
Maße " k1 " ist für Bremsenmotoren.

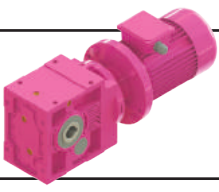

# Ölçü Sayfaları Dimension Pages Abmessungsseiten



-Mil ucu çektirme deliği DIN 332 sayfa 2 / Tapped center hole to DIN 332, sheet 2 / Zentrierung mit gewinde DIN 332, Blatt 2

## KV873.00

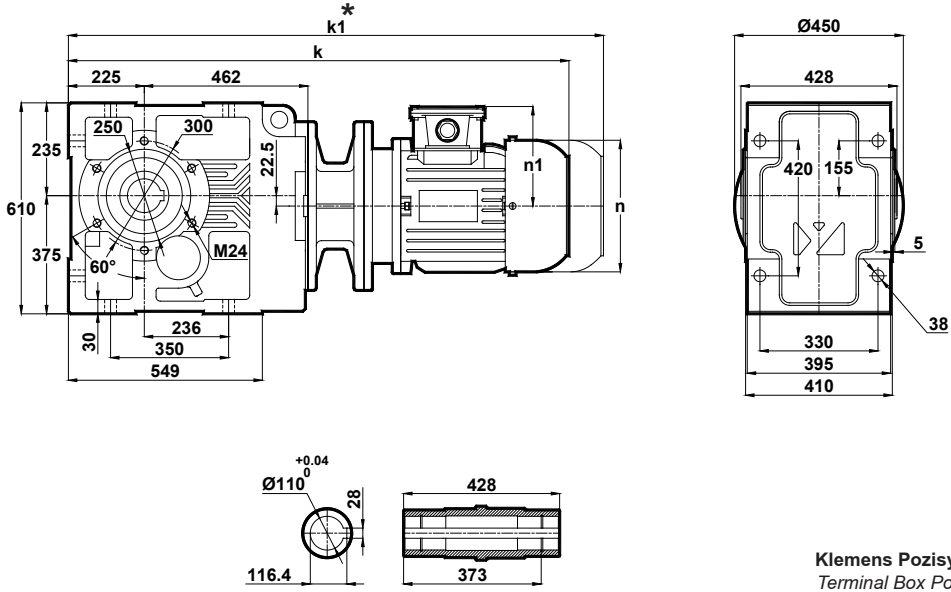

	160M/B5	160L/B5	180M/B5	180L/B5	200L/B5	225S/B5	225M/B5	250M/B5	280S/B5	280M/B5
k	1395	1439	1452	1490	1542	1560	1585	1661	1723	1723
k1	1595	1609	1622	1660	1742	-	-	-	-	-
n	310	310	348	348	390	433	433	480	544	544
n1	225	225	241	241	275	285	285	322	350	350

Klemens Pozisyonları  
Terminal Box Positions  
Klemmenkasten Positionen

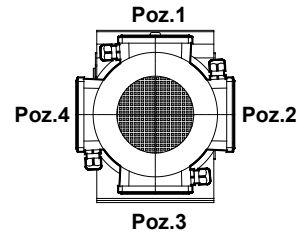

160-180-200-225-250-280  
Tip / Type / Typ

## KV873.01

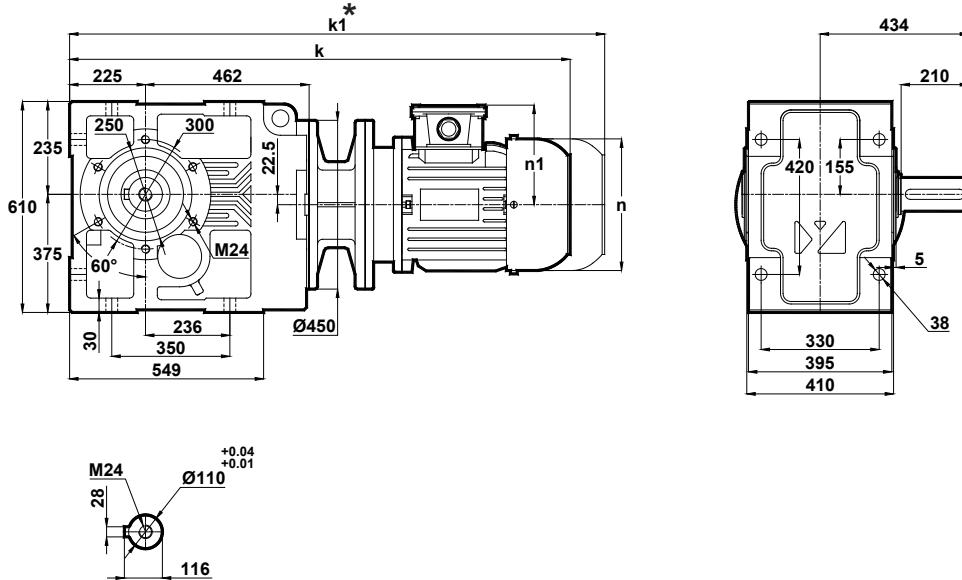

	160M/B5	160L/B5	180M/B5	180L/B5	200L/B5	225S/B5	225M/B5	250M/B5	280S/B5	280M/B5
k	1395	1439	1452	1490	1542	1560	1585	1661	1723	1723
k1	1595	1609	1622	1660	1742	-	-	-	-	-
n	310	310	348	348	390	433	433	480	544	544
n1	225	225	241	241	275	285	285	322	350	350

\* "k1" Ölçüsü frenli redüktörlere aittir.  
Dimension "k1" is for motors with brake.  
Maße "k1" ist für Bremsenmotoren.

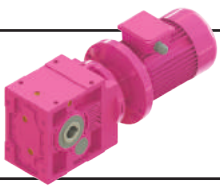

# Ölçü Sayfaları Dimension Pages Abmessungsseiten

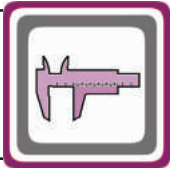

-Mil ucu çektirme deliği DIN 332 sayfa 2 / Tapped center hole to DIN 332, sheet 2 / Zentrierung mit gewinde DIN 332, Blatt 2

## KV873.02

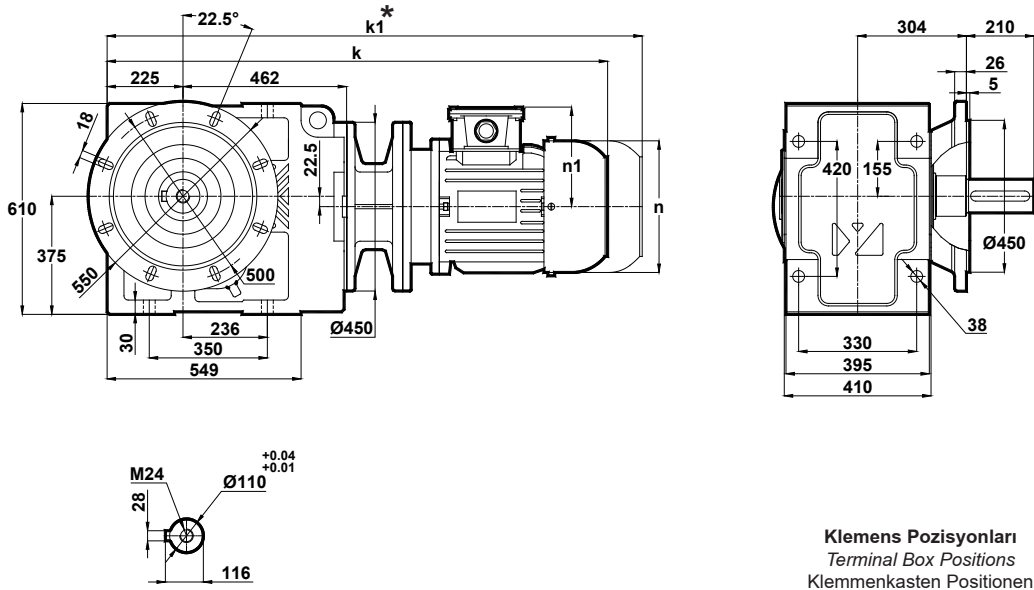

Klemens Pozisyonları  
Terminal Box Positions  
Klemmenkasten Positionen

	160M/B5	160L/B5	180M/B5	180L/B5	200L/B5	225S/B5	225M/B5	250M/B5	280S/B5	280M/B5
k	1395	1439	1452	1490	1542	1560	1585	1661	1723	1723
k1	1595	1609	1622	1660	1742	-	-	-	-	-
n	310	310	348	348	390	433	433	480	544	544
n1	225	225	241	241	275	285	285	322	350	350

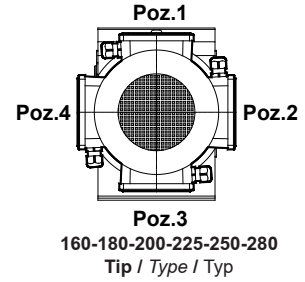

## KV873.03

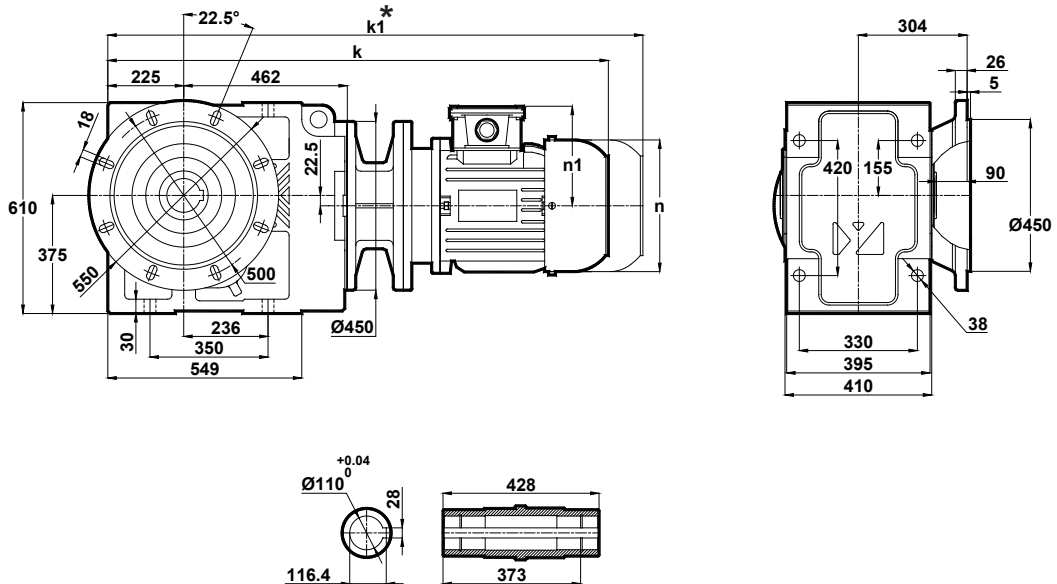

	160M/B5	160L/B5	180M/B5	180L/B5	200L/B5	225S/B5	225M/B5	250M/B5	280S/B5	280M/B5
k	1395	1439	1452	1490	1542	1560	1585	1661	1723	1723
k1	1595	1609	1622	1660	1742	-	-	-	-	-
n	310	310	348	348	390	433	433	480	544	544
n1	225	225	241	241	275	285	285	322	350	350

\* " k1 " Ölçüsü frenli redüktörlere aittir.  
Dimension " k1 " is for motors with brake.  
Maße " k1 " ist für Bremsenmotoren.

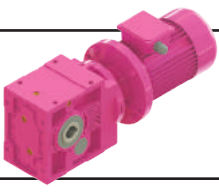

# Ölçü Sayfaları Dimension Pages Abmessungenseiten



-Mil ucu çekirme deliği DIN 332 sayfa 2 / Tapped center hole to DIN 332, sheet 2 / Zentrierung mit gewinde DIN 332, Blatt 2

## KV873.04

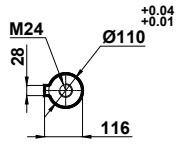
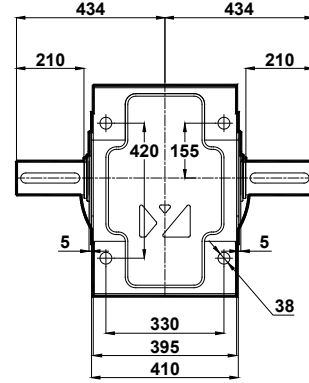
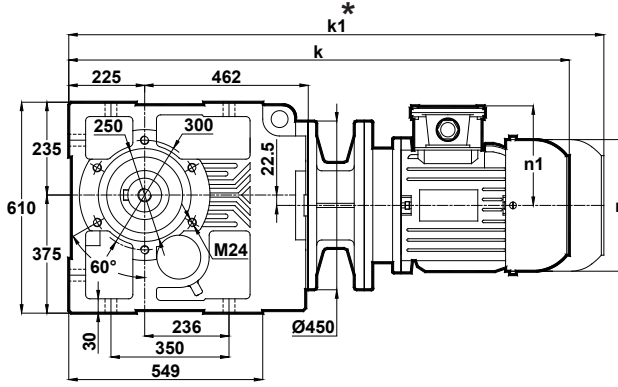

Klemens Pozisyonları  
Terminal Box Positions  
Klemmenkasten Positionen

	160M/B5	160L/B5	180M/B5	180L/B5	200L/B5	225S/B5	225M/B5	250M/B5	280S/B5	280M/B5
k	1395	1439	1452	1490	1542	1560	1585	1661	1723	1723
k1	1565	1609	1622	1660	1742	-	-	-	-	-
n	310	310	348	348	390	433	433	480	544	544
n1	225	225	241	241	275	285	285	322	350	350

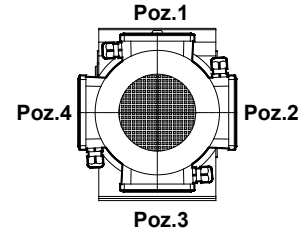

160-180-200-225-250-280  
Tip / Type / Typ

## KV873.05

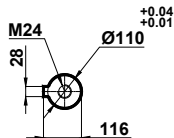
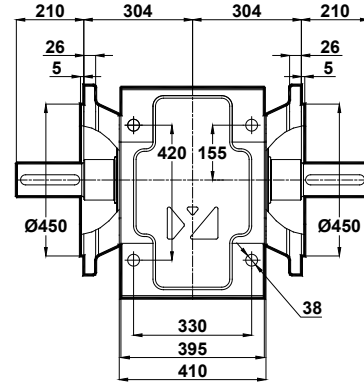
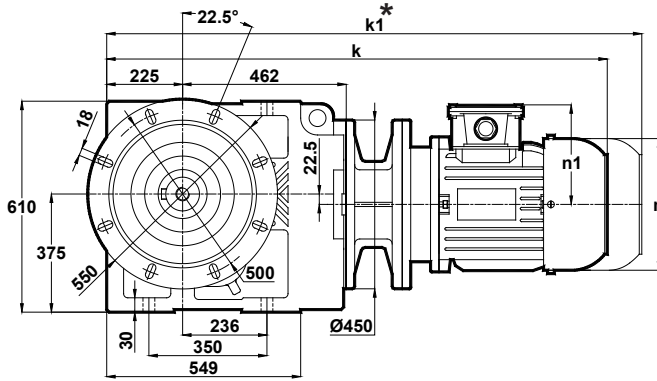

	160M/B5	160L/B5	180M/B5	180L/B5	200L/B5	225S/B5	225M/B5	250M/B5	280S/B5	280M/B5
k	1395	1439	1452	1490	1542	1560	1585	1661	1723	1723
k1	1595	1609	1622	1660	1742	-	-	-	-	-
n	310	310	348	348	390	433	433	480	544	544
n1	225	225	241	241	275	285	285	322	350	350

\* "k1" Ölçüsü frenli redüktörlere aittir.  
Dimension "k1" is for motors with brake.  
Maße "k1" ist für Bremsenmotoren.

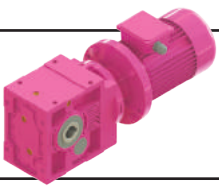

# Ölçü Sayfaları Dimension Pages Abmessungsseiten

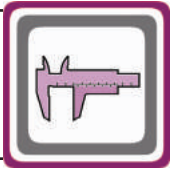

-Mil ucu çekirme deliği DIN 332 sayfa 2 / Tapped center hole to DIN 332, sheet 2 / Zentrierung mit gewinde DIN 332, Blatt 2

KV873.08

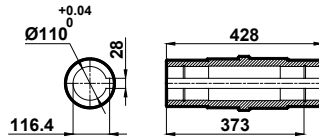
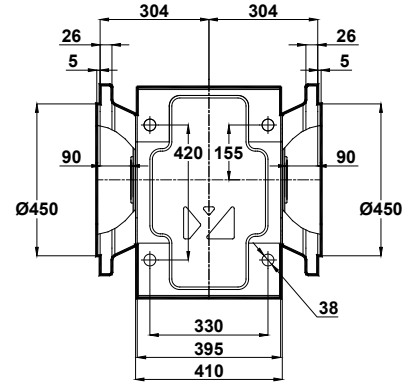
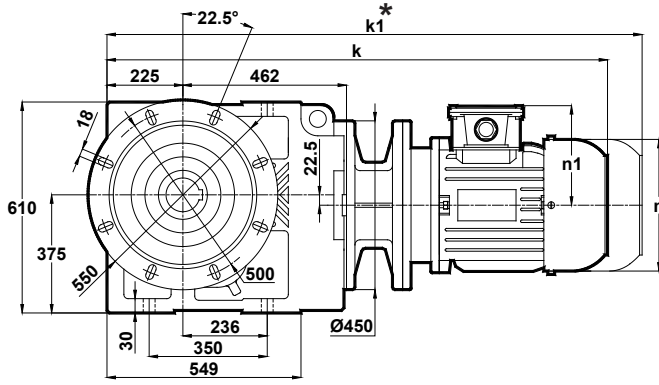

Klemens Pozisyonları  
Terminal Box Positions  
Klemmenkasten Positionen

	160M/B5	160L/B5	180M/B5	180L/B5	200L/B5	225S/B5	225M/B5	250M/B5	280S/B5	280M/B5
k	1395	1439	1452	1490	1542	1560	1585	1661	1723	1723
k1	1595	1609	1622	1660	1742	-	-	-	-	-
n	310	310	348	348	390	433	433	480	544	544
n1	225	225	241	241	275	285	285	322	350	350

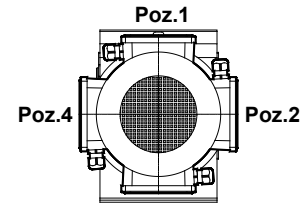

Poz.3  
160-180-200-225-250-280  
Tip / Type / Typ

\* " k1 " Ölçüsü frenli redüktörlere aittir.  
Dimension " k1 " is for motors with brake.  
Maße " k1 " ist für Bremsenmotoren.

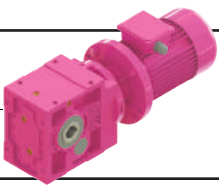

# Ölçü Sayfaları Dimension Pages Abmessungsseiten



-Mil ucu çektirme deliği DIN 332 sayfa 2 / Tapped center hole to DIN 332, sheet 2 / Zentrierung mit gewinde DIN 332, Blatt 2

## KV874.00

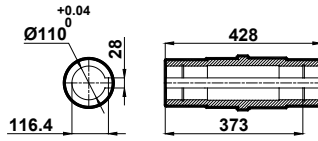
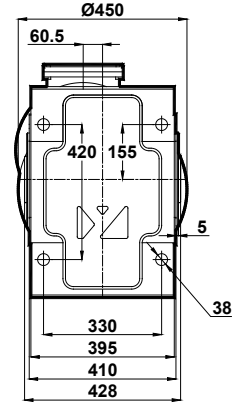
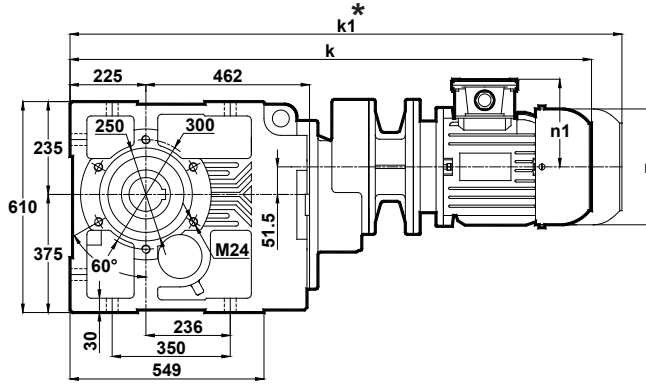

	100L/B5	112M/B5	132S/B5	132M/B5	160M/B5	160L/B5	180M/B5
k	1194	1214	1279	1317	1464	1508	1521
k1	1329	1349	1424	1462	1634	1678	1691
n	194	218	258	258	310	310	348
n1	135	146	168	168	225	225	241

Klemens Pozisyonları  
Terminal Box Positions  
Klemmenkasten Positionen

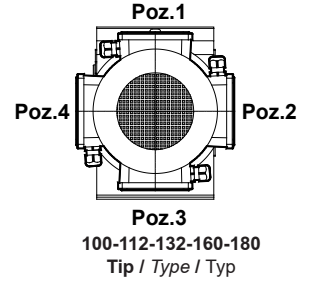

## KV874.01

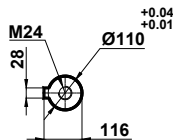
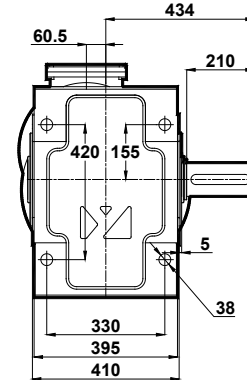
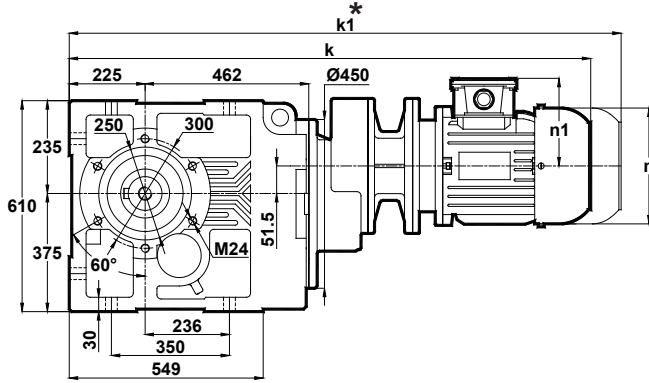

	100L/B5	112M/B5	132S/B5	132M/B5	160M/B5	160L/B5	180M/B5
k	1194	1214	1279	1317	1464	1508	1521
k1	1329	1349	1424	1462	1634	1678	1691
n	194	218	258	258	310	310	348
n1	135	146	168	168	225	225	241

\* "k1" Ölçüsü frenli redüktörlere aittir.  
Dimension "k1" is for motors with brake.  
Maße "k1" ist für Bremsmotoren.

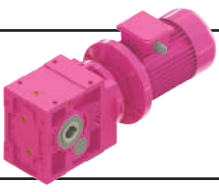

# Ölçü Sayfaları Dimension Pages Abmessungsseiten

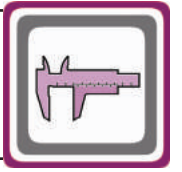

-Mil ucu çekirme deliği DIN 332 sayfa 2 / Tapped center hole to DIN 332, sheet 2 / Zentrierung mit gewinde DIN 332, Blatt 2

## KV874.02

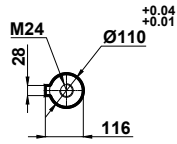
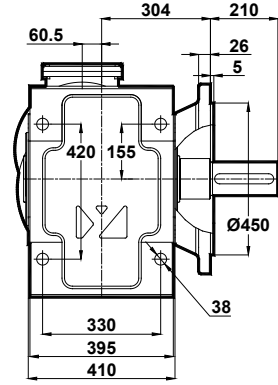
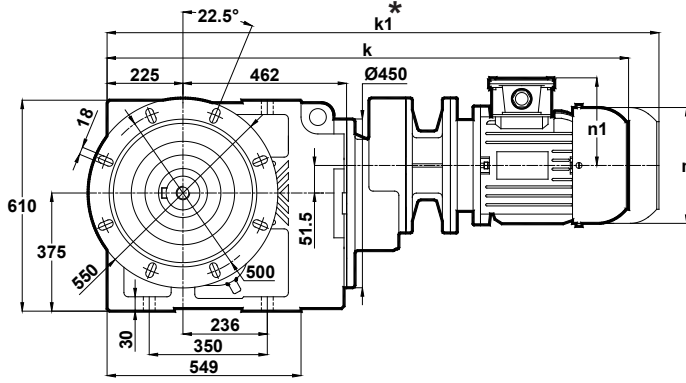

	100L/B5	112M/B5	132S/B5	132M/B5	160M/B5	160L/B5	180M/B5
k	1194	1214	1279	1317	1464	1508	1521
k1	1329	1349	1424	1462	1634	1678	1691
n	194	218	258	258	310	310	348
n1	135	146	168	168	225	225	241

Klemens Pozisyonları  
Terminal Box Positions  
Klemmenkasten Positionen

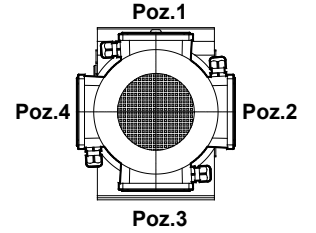

100-112-132-160-180  
Tip / Type / Typ

## KV874.03

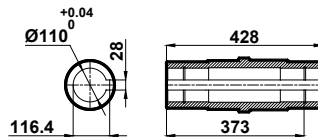
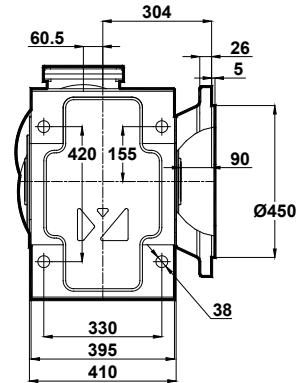
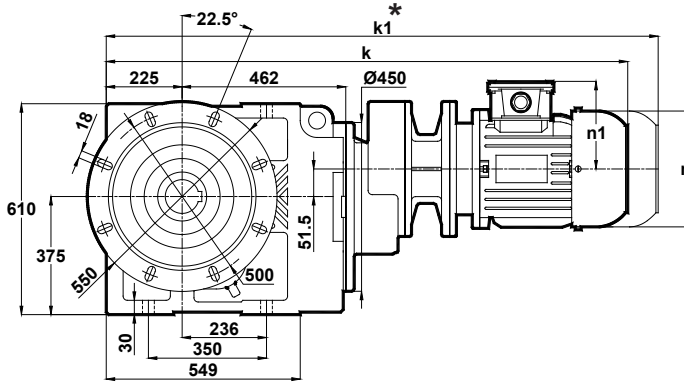

	100L/B5	112M/B5	132S/B5	132M/B5	160M/B5	160L/B5	180M/B5
k	1194	1214	1279	1317	1464	1508	1521
k1	1329	1349	1424	1462	1634	1678	1691
n	194	218	258	258	310	310	348
n1	135	146	168	168	225	225	241

\* " k1 " Ölçüsü frenli redüktörlere aittir.  
Dimension " k1 " is for motors with brake.  
Maße " k1 " ist für Bremsenmotoren.

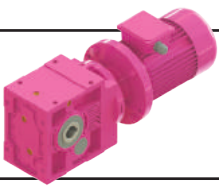

# Ölçü Sayfaları Dimension Pages Abmessungsseiten



-Mil ucu çekirme deliği DIN 332 sayfa 2 / Tapped center hole to DIN 332, sheet 2 / Zentrierung mit gewinde DIN 332, Blatt 2

## KV874.04

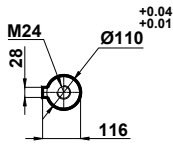
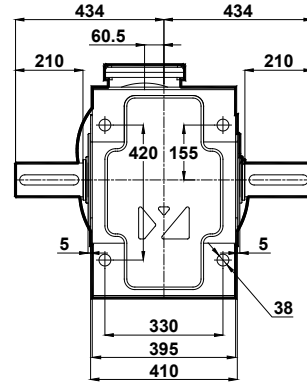
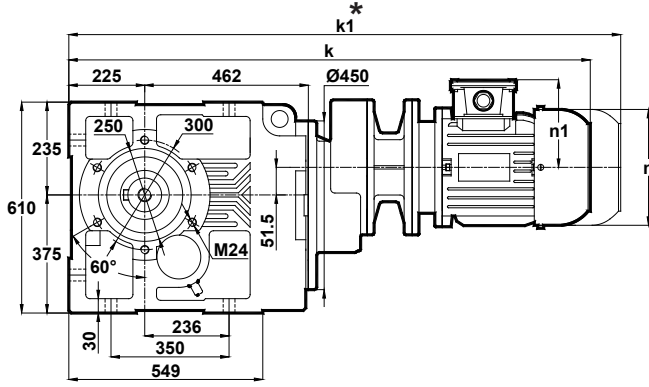

	100L/B5	112M/B5	132S/B5	132M/B5	160M/B5	160L/B5	180M/B5
k	1194	1214	1279	1317	1464	1508	1521
k1	1329	1349	1424	1462	1634	1678	1691
n	194	218	258	258	310	310	348
n1	135	146	168	168	225	225	241

Klemens Pozisyonları  
Terminal Box Positions  
Klemmenkasten Positionen

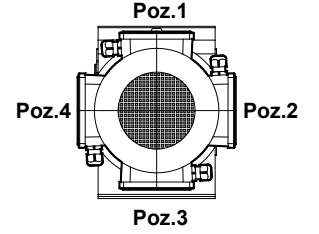

100-112-132-160-180  
Tip / Type / Typ

## KV874.05

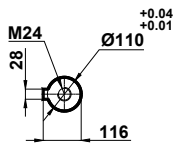
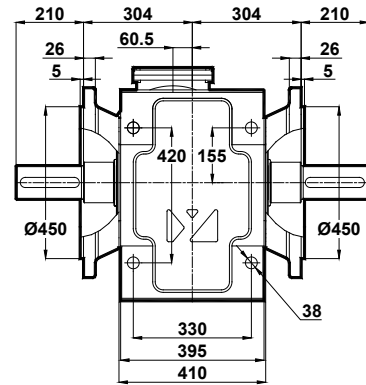
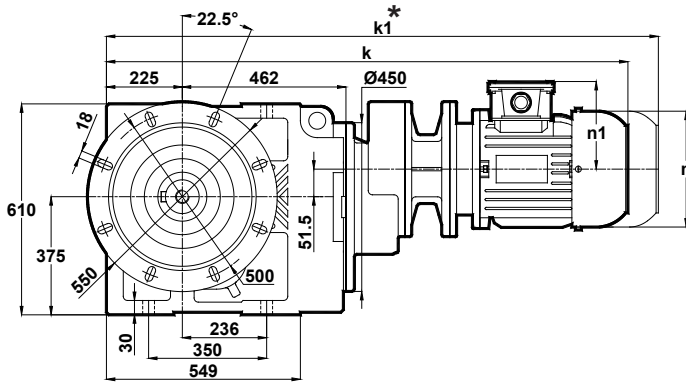

	100L/B5	112M/B5	132S/B5	132M/B5	160M/B5	160L/B5	180M/B5
k	1194	1214	1279	1317	1464	1508	1521
k1	1329	1349	1424	1462	1634	1678	1691
n	194	218	258	258	310	310	348
n1	135	146	168	168	225	225	241

\* "k1" Ölçüsü frenli redüktörlere aittir.  
Dimension "k1" is for motors with brake.  
Maße "k1" ist für Bremsenmotoren.

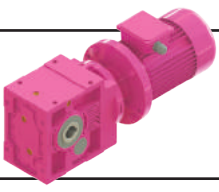

# Ölçü Sayfaları Dimension Pages Abmessungenseiten

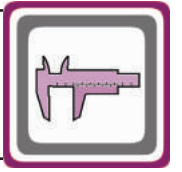

-Mil ucu çekirme deliği DIN 332 sayfa 2 / Tapped center hole to DIN 332, sheet 2 / Zentrierung mit gewinde DIN 332, Blatt 2

KV874.08

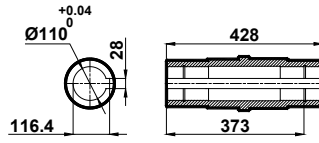
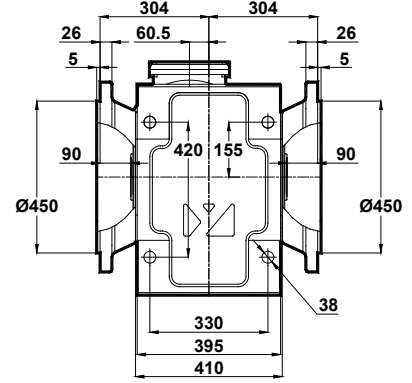
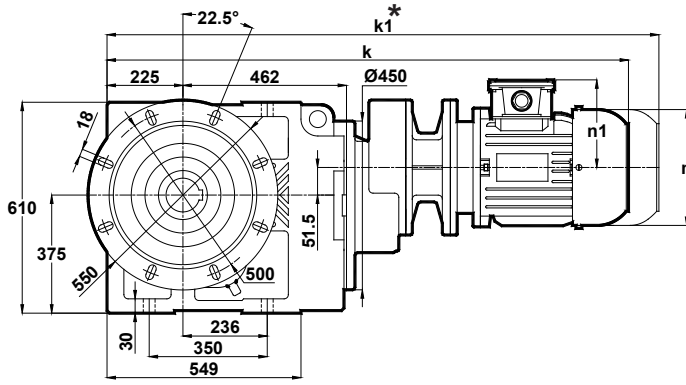

Klemens Pozisyonları  
Terminal Box Positions  
Klemmenkasten Positionen

	100L/B5	112M/B5	132S/B5	132M/B5	160M/B5	160L/B5	180M/B5
k	1194	1214	1279	1317	1464	1508	1521
k1	1329	1349	1424	1462	1634	1678	1691
n	194	218	258	258	310	310	348
n1	135	146	168	168	225	225	241

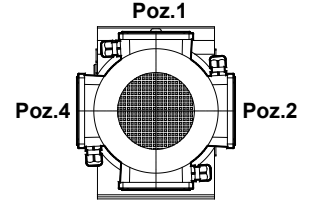

Poz.3  
100-112-132-160-180  
Tip / Type / Typ

\* " k1 " Ölçüsü frenli redüktörlere aittir.  
Dimension " k1 " is for motors with brake.  
Maße " k1 " ist für Bremsenmotoren.

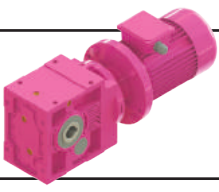

# Ölçü Sayfaları Dimension Pages Abmessungenseiten



-Mil ucu çektirme deliği DIN 332 sayfa 2 / Tapped center hole to DIN 332, sheet 2 / Zentrierung mit gewinde DIN 332, Blatt 2

KV875.00  
KV876.00

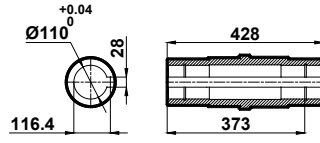
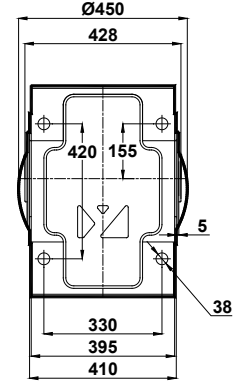
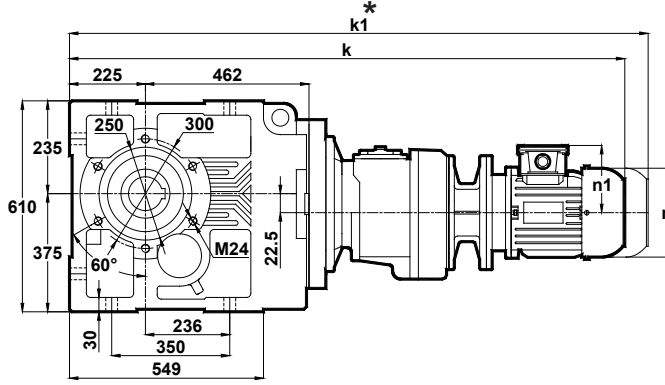

Klemens Pozisyonları  
Terminal Box Positions  
Klemmenkasten Positionen

	71/B5	80/B5	90S/B5	90L/B5	100L/B5	112M/B5
k	1216	1236	1256	1281	1330	1350
k1	1336	1356	1381	1406	1465	1485
n	138	156	176	176	194	218
n1	110	118	126	126	135	146

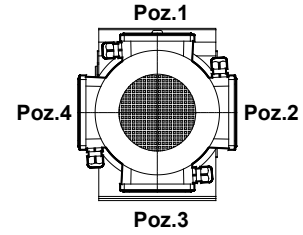

71-80-90-100-112  
Tip / Type / Typ

KV875.01  
KV876.01

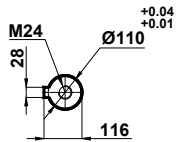
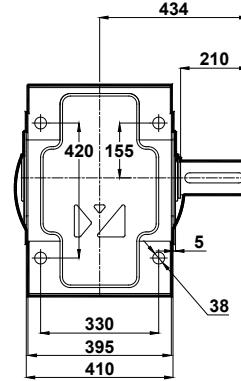
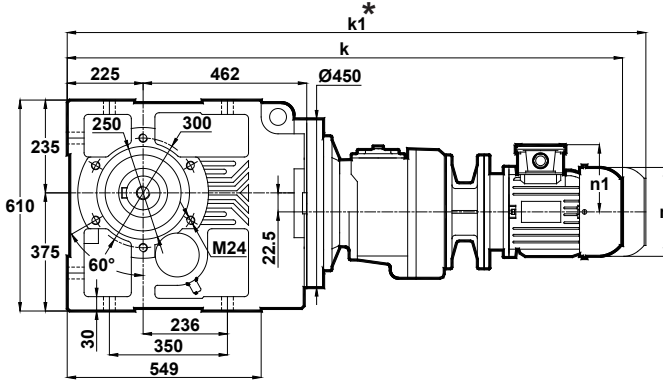

	71/B5	80/B5	90S/B5	90L/B5	100L/B5	112M/B5
k	1216	1236	1256	1281	1330	1350
k1	1336	1356	1381	1406	1465	1485
n	138	156	176	176	194	218
n1	110	118	126	126	135	146

\* "k1" Ölçüsü frenli redüktörlere aittir.  
Dimension "k1" is for motors with brake.  
Maße "k1" ist für Bremsenmotoren.

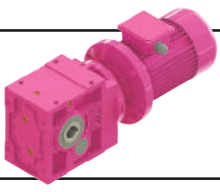

# Ölçü Sayfaları Dimension Pages Abmessungsseiten

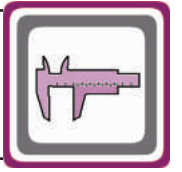

-Mil ucu çektirme deliği DIN 332 sayfa 2 / Tapped center hole to DIN 332, sheet 2 / Zentrierung mit gewinde DIN 332, Blatt 2

KV875.02  
KV876.02

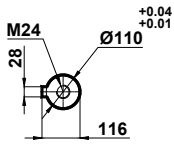
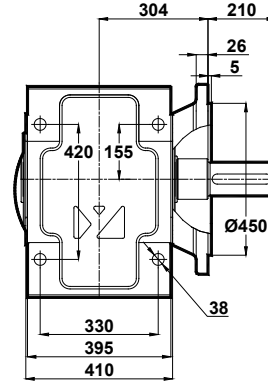
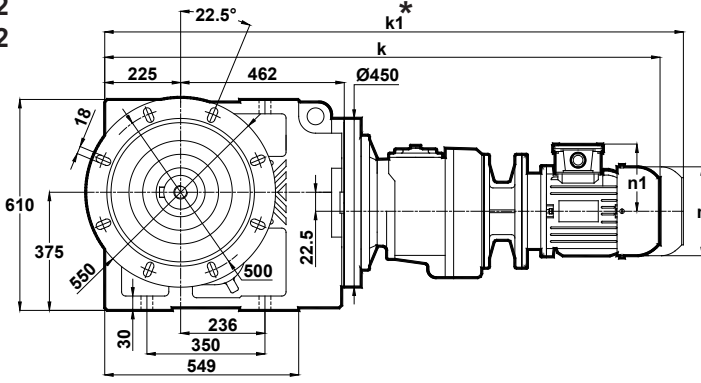

Klemens Pozisyonları  
Terminal Box Positions  
Klemmenkasten Positionen

	71/B5	80/B5	90S/B5	90L/B5	100L/B5	112M/B5
k	1216	1236	1256	1281	1330	1350
k1	1336	1356	1381	1406	1465	1485
n	138	156	176	176	194	218
n1	110	118	126	126	135	146

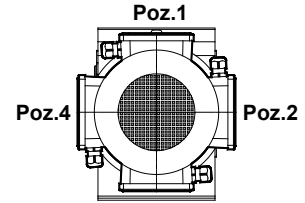

Poz.3  
71-80-90-100-112  
Tip / Type / Typ

KV875.03  
KV876.03

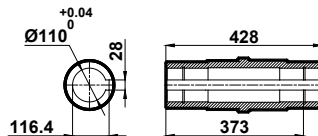
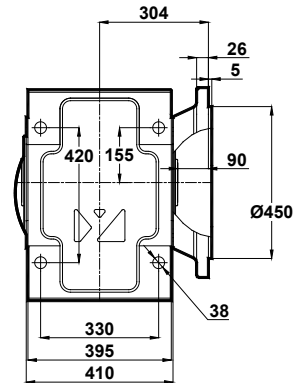
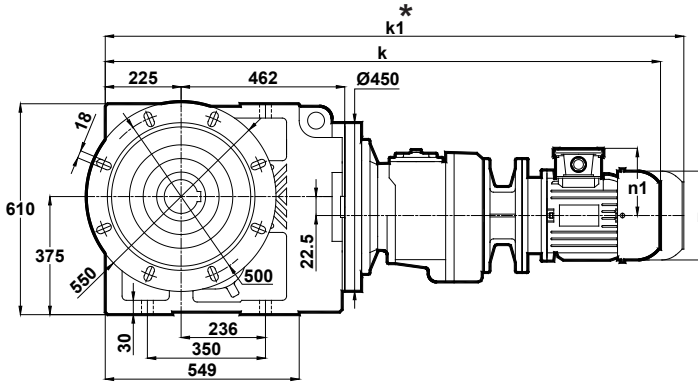

	71/B5	80/B5	90S/B5	90L/B5	100L/B5	112M/B5
k	1216	1236	1256	1281	1330	1350
k1	1336	1356	1381	1406	1465	1485
n	138	156	176	176	194	218
n1	110	118	126	126	135	146

\* " k1 " Ölçüsü frenli redüktörlere aittir.  
Dimension " k1 " is for motors with brake.  
Maße " k1 " ist für Bremsenmotoren.

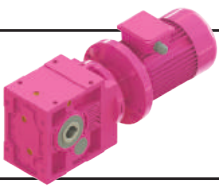

# Ölçü Sayfaları Dimension Pages Abmessungsseiten



-Mil ucu çektirme deliği DIN 332 sayfa 2 / Tapped center hole to DIN 332, sheet 2 / Zentrierung mit gewinde DIN 332, Blatt 2

KV875.04  
KV876.04

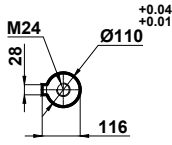
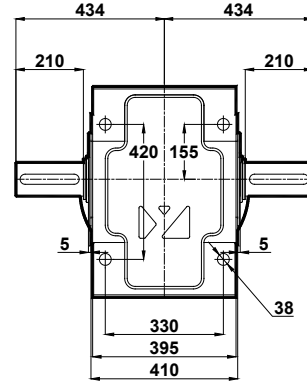
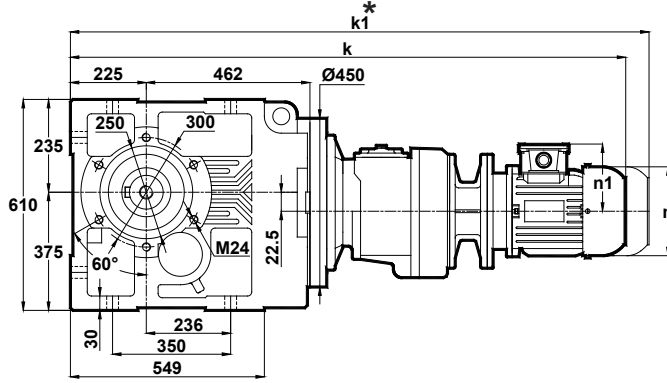

	71/B5	80/B5	90S/B5	90L/B5	100L/B5	112M/B5
k	1216	1236	1256	1281	1330	1350
k1	1336	1356	1381	1406	1465	1485
n	138	156	176	176	194	218
n1	110	118	126	126	135	146

Klemens Pozisyonları  
Terminal Box Positions  
Klemmenkasten Positionen

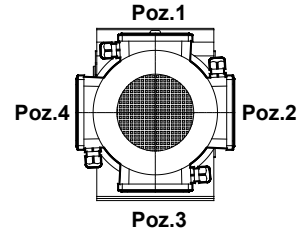

71-80-90-100-112  
Tip / Type / Typ

KV875.05  
KV876.05

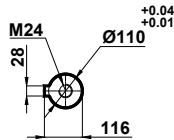
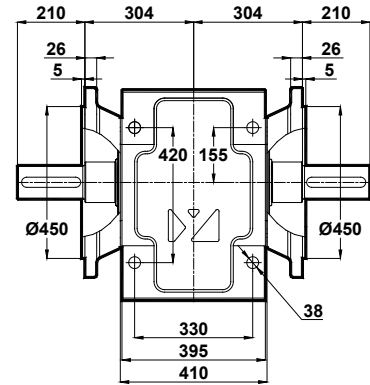
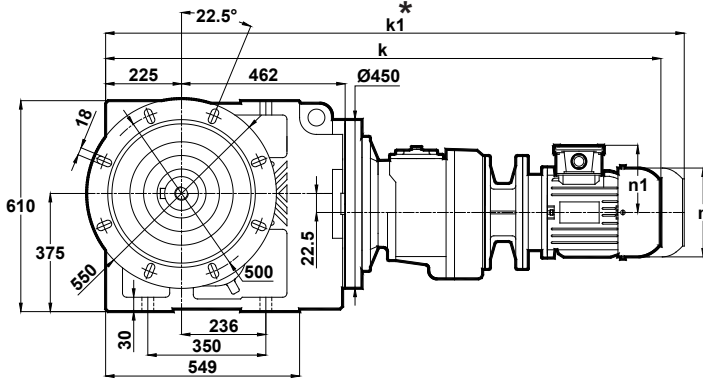

	71/B5	80/B5	90S/B5	90L/B5	100L/B5	112M/B5
k	1216	1236	1256	1281	1330	1350
k1	1336	1356	1381	1406	1465	1485
n	138	156	176	176	194	218
n1	110	118	126	126	135	146

\* "k1" Ölçüsü frenli redüktörlere aittir.  
Dimension "k1" is for motors with brake.  
Maße "k1" ist für Bremsenmotoren.

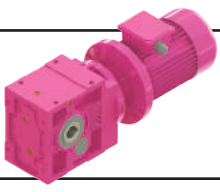

# Ölçü Sayfaları Dimension Pages Abmessungsseiten

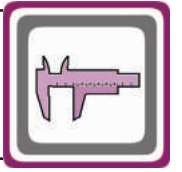

-Mil ucu çektirme deliği DIN 332 sayfa 2 / Tapped center hole to DIN 332, sheet 2 / Zentrierung mit gewinde DIN 332, Blatt 2

KV875.08  
KV876.08

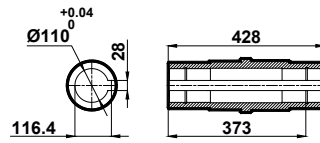
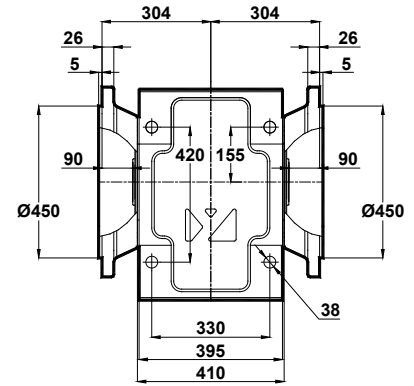
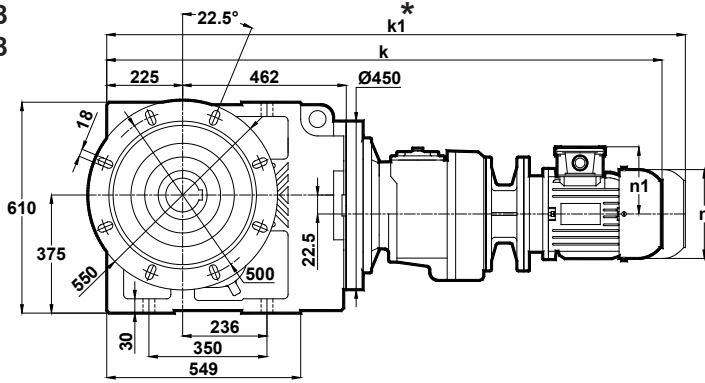

	71/B5	80/B5	90S/B5	90L/B5	100L/B5	112M/B5
k	1216	1236	1256	1281	1330	1350
k1	1336	1356	1381	1406	1465	1485
n	138	156	176	176	194	218
n1	110	118	126	126	135	146

Klemens Pozisyonları  
Terminal Box Positions  
Klemmenkasten Positionen

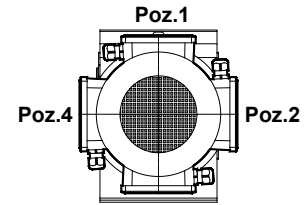

Poz.3  
71-80-90-100-112  
Tip / Type / Typ

\* " k1 " Ölçüsü frenli redüktörlere aittir.  
Dimension " k1 " is for motors with brake.  
Maße " k1 " ist für Bremsenmotoren.



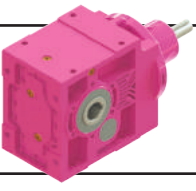

# Güç ve Devir Tabloları

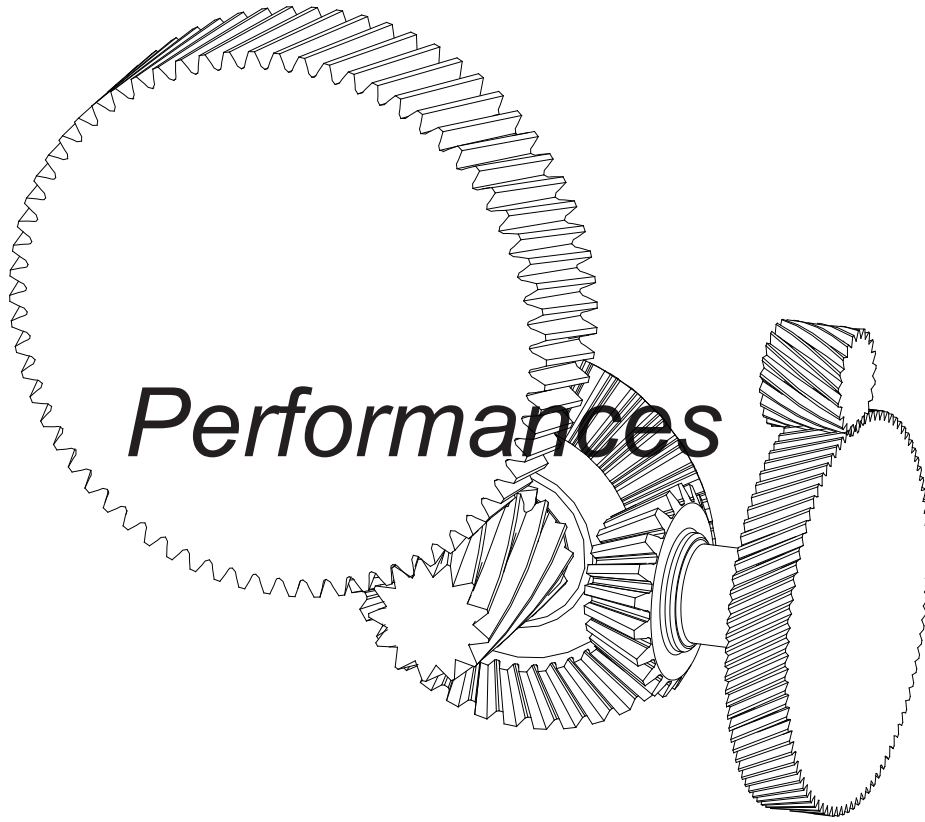

## Leistung und Drehzahlübersicht

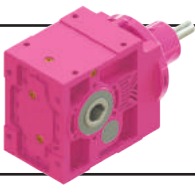

# K Serisi Motorsuz Güç Devir Sayfaları

## K Series Gear Units Performance Tables

### K Serien Getriebe Leistung und Drehzahlübersicht



Anma Momenti Nominal Torques Nenn-drehmomente Ma [Nm] (n1=1400rpm)	Çevrim Oranı Ratio Übersetzung i	Çıkış Devri Output Speeds Abtriebs-drehzahlen n2 [r.p.m] (n1=1400rpm)	Tipi Type Typ	Pe= Nominal Güç [kW] (Servis Faktörü fs=1,0 için) Pe= Nominal Power [kW] (For Service Factor fs=1,0) Pe= NennLeistung [kW] (Bei Betriebsfaktor fs=1,0)						Güv. Rad.Yük Çıkış Per.O.Loads (Output)	Güv.Rad.Yük Giriş Per.O.Loads (Input)	Ağırlık Weight Gewicht [kg]	Ölçü Sayfası Dim. Page Maße Seite	Fiyat Kodu Price Ref. Preis No.
	Giriş devri[d/d] / Input speed[rpm] / Antriebsdrehzahl[upm]						Zul.Querkräfte (Abtrieb)	Zul.Querkräfte (Antrieb)	Fqam [N] (n1=1400rpm)	Fqem [N] (n1=1400rpm)	Fiyat Kodu	Fiyat Kodu		
	n1=2800	n1=1400		n1=900	n1=750	n1=450	n1=350	Fiyat Kodu					Fiyat Kodu	
65	7,46	188	KT002	2,27	1,35	1,00	0,89	0,54	0,42	2703	63	14	374	KT028
65	8,04	174		2,10	1,25	0,93	0,83	0,50	0,39	2789	114			
70	9,40	149		1,81	1,15	0,85	0,71	0,43	0,33	2921	71			
75	11,09	126		1,67	1,05	0,72	0,60	0,36	0,28	3076	32			
75	13,26	106		1,40	0,88	0,61	0,50	0,30	0,24	3312	119			
75	14,73	95		1,26	0,79	0,55	0,45	0,27	0,21	3457	201			
75	16,18	87		1,15	0,72	0,50	0,41	0,25	0,19	3590	234			
80	19,88	70		1,02	0,63	0,41	0,34	0,20	0,16	3848	185			
80	23,79	59	KT003	0,93	0,53	0,34	0,29	0,17	0,13	3207	776	15	374	KT029
80	25,64	55		0,86	0,50	0,32	0,27	0,16	0,13	3324	782			
80	29,95	47		0,79	0,43	0,28	0,23	0,14	0,11	3577	793			
80	35,34	40		0,68	0,36	0,23	0,20	0,12	0,09	3860	803			
80	45,41	31		0,56	0,28	0,18	0,15	0,09	0,07	4050	880			
80	48,93	29		0,52	0,26	0,17	0,14	0,09	0,07	4050	884			
80	57,16	24		0,45	0,23	0,15	0,12	0,07	0,06	4050	889			
80	67,44	21		0,39	0,19	0,13	0,10	0,06	0,05	4050	894			
80	80,66	18		0,33	0,16	0,11	0,09	0,05	0,04	4050	899			
80	89,62	16		0,29	0,15	0,10	0,08	0,05	0,04	4050	904			
80	98,44	14		0,27	0,14	0,09	0,07	0,04	0,03	4050	905			
80	120,91	12		0,22	0,11	0,07	0,06	0,04	0,03	4050	908			
90	6,28	223	KT102	3,41	2,20	1,66	1,84	1,11	0,86	2828	-	15	378	KT030
90	7,29	192		3,15	1,90	1,43	1,59	0,96	0,75	3016	-			
95	8,72	161		2,82	1,68	1,25	1,33	0,80	0,62	3208	-			
100	10,32	136		2,38	1,50	1,11	1,13	0,68	0,53	3398	-			
100	11,05	127		2,37	1,40	1,08	1,05	0,63	0,49	3498	-			
105	12,51	112		2,09	1,30	0,96	0,93	0,56	0,44	3639	-			
110	14,61	96		1,90	1,17	0,89	0,80	0,48	0,37	3837	-			
110	17,30	81		1,61	0,99	0,75	0,68	0,41	0,32	4122	-			
110	19,43	72		1,44	0,88	0,67	0,60	0,36	0,28	4326	-			
115	21,25	66		1,39	0,84	0,61	0,55	0,33	0,26	4441	-			
120	25,50	55		1,22	0,74	0,55	0,46	0,28	0,22	4741	-			
115	20,03	70		KT103	1,40	0,90	0,66	0,57	0,36	0,28	4240			
120	23,22	60	1,28		0,81	0,59	0,51	0,31	0,24	4464	721			
125	27,81	50	1,13		0,71	0,51	0,43	0,26	0,20	4768	733			
130	32,90	43	1,00		0,63	0,44	0,36	0,22	0,17	5068	737			
135	35,22	40	0,98		0,61	0,41	0,34	0,20	0,16	5162	733			
135	38,22	37	0,91		0,56	0,37	0,31	0,19	0,15	5346	823			
140	44,32	32	0,82		0,50	0,32	0,27	0,16	0,13	5637	828			
140	53,07	26	0,72		0,42	0,27	0,23	0,14	0,11	5850	842			
140	62,79	22	0,63		0,36	0,23	0,19	0,12	0,09	5850	849			
140	67,22	21	0,62		0,33	0,22	0,18	0,11	0,08	5850	853			
140	76,13	18	0,57		0,30	0,19	0,16	0,10	0,07	5850	856			
140	88,87	16	0,51		0,26	0,16	0,14	0,08	0,06	5850	861			
140	105,26	13	0,43		0,22	0,14	0,12	0,07	0,05	5850	866			
140	118,19	12	0,39		0,19	0,13	0,10	0,06	0,05	5850	874			
140	129,27	11	0,36		0,18	0,12	0,10	0,06	0,04	5850	876			
195	5,35	262	KT202		8,81	5,57	4,05	3,61	2,50	2,02	2204	-	19	382
205	6,38	219		7,87	4,91	3,63	3,16	2,17	1,69	2353	-			
215	7,65	183		6,97	4,30	3,16	2,80	1,81	1,41	2523	60			
230	9,25	151		6,11	3,81	2,78	2,45	1,50	1,17	2680	74			
235	10,57	132		5,50	3,42	2,53	2,19	1,32	1,03	2848	186			
245	12,17	115		5,03	3,10	2,28	1,90	1,15	0,89	2996	189			
255	14,32	98		4,39	2,74	1,94	1,62	0,97	0,76	3193	198			
260	15,26	92		4,22	2,62	1,82	1,52	0,91	0,71	3266	180			
270	17,47	80		3,78	2,39	1,59	1,33	0,80	0,62	3433	144			
280	20,23	69		3,42	2,14	1,38	1,15	0,69	0,54	3635	110			
280	23,79	59	3,05	1,82	1,18	0,98	0,59	0,46	3966	248				

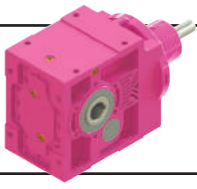

# K Serisi Motorsuz Güç Devir Sayfaları

## K Series Gear Units Performance Tables

### K Serien Getriebe Leistung und Drehzahlübersicht



Anma Momenti Nominal Torques Nenn-drehmomente Ma [Nm] (n1=1400rpm)	Çevrim Oranı Ratio Übersetzung i	Çıkış Devri Output Speeds Abtriebs-drehzahlen n2 [r.p.m] (n1=1400rpm)	Tipi Type Typ	Pe= Nominal Güç [kW] (Servis Faktörü fs=1,0 için) Pe= Nominal Power [kW] (For Service Factor fs=1,0) Pe= NennLeistung [kW] (Bei Betriebsfaktor fs=1,0)						Güv. Rad.Yük Çıkış Per.O.Loads (Output) Zul.Querkräfte (Abtrieb) Fqam [N] (n1=1400rpm)	Güv.Rad.Yük Giriş Per.O.Loads (Input) Zul.Querkräfte (Antrieb) Fqem [N] (n1=1400rpm)	Ağırlık Weight Gewicht [kg]	Ölçü Sayfası Dim. Page Maße Seite	Fiyat Kodu Price Ref. Preis No.
				Giriş devri[d/d] / Input speed[rpm] / Antriebsdrehzahl[upm]										
				n1=2800	n1=1400	n1=900	n1=750	n1=450	n1=350					
<b>250</b>	22,06	63	<b>KT203</b>	2,87	<b>1,77</b>	1,28	1,07	0,64	0,50	3766	1727	20	382	KT033
<b>265</b>	26,31	53		2,53	<b>1,57</b>	1,07	0,90	0,54	0,42	3996	1737			
<b>280</b>	31,55	44		2,22	<b>1,39</b>	0,90	0,75	0,45	0,35	4261	1746			
<b>280</b>	36,61	38		2,00	<b>1,20</b>	0,77	0,65	0,39	0,30	4629	1845			
<b>280</b>	43,67	32		1,78	<b>1,01</b>	0,65	0,54	0,33	0,25	5086	1865			
<b>280</b>	52,37	27		1,58	<b>0,84</b>	0,54	0,45	0,27	0,21	5581	1883			
<b>280</b>	63,33	22		1,39	<b>0,70</b>	0,45	0,38	0,23	0,18	6131	1898			
<b>280</b>	72,37	19		1,22	0,61	0,40	0,33	0,20	0,15	6536	1906			
<b>280</b>	83,32	17		1,06	<b>0,53</b>	0,34	0,29	0,17	0,13	6983	1915			
<b>280</b>	98,01	14		0,91	<b>0,46</b>	0,29	0,25	0,15	0,11	7500	1922			
<b>280</b>	104,49	13		0,85	<b>0,43</b>	0,28	0,23	0,14	0,11	7500	1925			
<b>280</b>	119,62	12		0,75	<b>0,38</b>	0,24	0,20	0,12	0,09	7500	1930			
<b>280</b>	138,53	10		0,65	<b>0,33</b>	0,21	0,18	0,11	0,08	7500	1935			
<b>220</b>	6,94	202	<b>KT273</b>	8,5	<b>5,0</b>	3,9	3,4	2,4	2,0	10876	420	25	386	KT001
<b>230</b>	8,28	169		7,5	<b>4,3</b>	3,4	3,0	2,1	1,7	11484	525			
<b>240</b>	9,92	141		6,6	<b>3,8</b>	2,9	2,6	1,8	1,5	12152	616			
<b>250</b>	12,00	117		5,7	<b>3,3</b>	2,6	2,3	1,6	1,3	12600	696			
<b>350</b>	13,34	105		7,0	<b>4,1</b>	3,2	2,8	1,7	1,3	12600	892			
<b>370</b>	15,92	88		6,1	<b>3,6</b>	2,8	2,4	1,4	1,1	12500	954			
<b>390</b>	19,08	73		5,4	<b>3,2</b>	2,4	2,0	1,2	0,92	12400	1008			
<b>410</b>	23,08	61		4,7	<b>2,8</b>	2,0	1,6	0,98	0,76	12250	1057			
<b>430</b>	25,55	55		4,4	<b>2,6</b>	1,8	1,5	0,88	0,69	12100	1240			
<b>450</b>	30,48	46		3,9	<b>2,3</b>	1,5	1,2	0,74	0,58	12000	1255			
<b>450</b>	36,55	38		3,4	<b>1,9</b>	1,2	1,0	0,62	0,48	12000	1280			
<b>450</b>	44,20	32		3,0	<b>1,6</b>	1,0	0,85	0,51	0,40	12000	1303			
<b>450</b>	50,51	28		2,7	<b>1,4</b>	0,89	0,74	0,45	0,35	12000	1316			
<b>450</b>	58,15	24		2,4	<b>1,2</b>	0,78	0,65	0,39	0,30	12000	1328			
<b>450</b>	68,40	20		2,1	<b>1,0</b>	0,66	0,55	0,33	0,26	12000	1340			
<b>450</b>	72,92	19		1,9	<b>0,96</b>	0,62	0,52	0,31	0,27	12000	1344			
<b>450</b>	83,48	17		1,7	<b>0,84</b>	0,54	0,45	0,27	0,23	12000	1352			
<b>450</b>	96,68	14		1,5	<b>0,73</b>	0,47	0,39	0,26	0,20	12000	1360			
<b>450</b>	113,65	12		1,2	<b>0,62</b>	0,40	0,33	0,22	0,17	12000	1367			
<b>450</b>	112,73	12	<b>KT275</b>	1,3	<b>0,66</b>	0,42	0,35	0,23	0,18	12000	592	28	390	KT002
<b>450</b>	131,68	11		1,1	<b>0,56</b>	0,36	0,30	0,20	0,16	12000	602			
<b>450</b>	200,35	7,0		0,74	<b>0,37</b>	0,27	0,22	0,13	0,10	12000	675			
<b>450</b>	215,91	6,5		0,69	<b>0,34</b>	0,25	0,21	0,12	0,10	12000	678			
<b>450</b>	252,20	5,6		0,59	<b>0,30</b>	0,21	0,18	0,11	0,08	12000	683			
<b>450</b>	300,85	4,7		0,55	<b>0,28</b>	0,20	0,16	0,10	0,08	12000	697			
<b>450</b>	360,73	3,9		0,46	<b>0,23</b>	0,16	0,14	0,08	0,06	12000	710			
<b>450</b>	436,24	3,2		0,38	<b>0,19</b>	0,14	0,11	0,07	0,05	12000	720			
<b>450</b>	498,55	2,8		0,33	<b>0,17</b>	0,12	0,10	0,06	0,05	12000	727			
<b>450</b>	573,99	2,4		0,29	<b>0,15</b>	0,10	0,09	0,05	0,04	12000	733			
<b>450</b>	675,13	2,1		0,27	<b>0,12</b>	0,09	0,07	0,04	0,03	12000	738			
<b>450</b>	719,79	1,9		0,26	<b>0,12</b>	0,08	0,07	0,04	0,03	12000	740			
<b>450</b>	735,42	1,9	<b>KT276</b>	0,26	<b>0,12</b>	0,08	0,07	0,04	0,03	12000	742	30	390	KT003
<b>450</b>	881,79	1,6		0,21	<b>0,10</b>	0,07	0,06	0,03	0,03	12000	747			
<b>450</b>	1066,35	1,3		0,18	<b>0,08</b>	0,06	0,05	0,03	0,02	12000	751			
<b>450</b>	1218,69	1,1		0,16	<b>0,07</b>	0,05	0,04	0,02	0,02	12000	754			
<b>450</b>	1403,10	1,0		0,14	<b>0,06</b>	0,04	0,04	0,02	0,02	12000	756			
<b>450</b>	1650,31	0,85		0,11	<b>0,05</b>	0,04	0,03	0,02	0,01	12000	758			
<b>450</b>	1759,48	0,80		0,11	<b>0,05</b>	0,03	0,03	0,02	0,01	12000	759			
<b>580</b>	5,68	247	<b>KT373</b>	26	<b>16</b>	12	10	7,2	5,6	11009	-	60	394	KT004
<b>595</b>	6,63	211		23	<b>14</b>	10	9,1	6,2	4,8	11617	-			
<b>610</b>	7,73	181		20	<b>12</b>	9,1	8,1	5,3	4,1	12253	-			
<b>630</b>	8,54	164		19	<b>12</b>	8,5	7,4	4,8	3,7	12616	-			
<b>655</b>	9,97	140		17	<b>10</b>	7,5	6,6	4,1	3,2	13248	-			
<b>805</b>	10,60	132		19	<b>12</b>	7,8	6,5	3,9	3,0	12100	-			
<b>820</b>	12,38	113		17	<b>10</b>	6,6	5,5	3,3	2,6	11800	-			
<b>820</b>	14,44	97		15	<b>8,9</b>	5,7	4,7	2,9	2,2	11800	-			

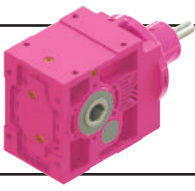

# K Serisi Motorsuz Güç Devir Sayfaları

## K Series Gear Units Performance Tables

### K Serien Getriebe Leistung und Drehzahlübersicht



Anma Momenti <i>Nominal Torques</i> Nenn-drehmomente Ma [Nm] (n1=1400rpm)	Çevrim Oranı <i>Ratio</i> Übersetzung i	Çıkış Devri <i>Output Speeds</i> Abtriebs-drehzahlen n2 [r.p.m] (n1=1400rpm)	Tipi <i>Type</i> Typ	Pe= Nominal Güç [kW] (Servis Faktörü fs=1,0 için) <i>Pe= Nominal Power [kW] (For Service Factor fs=1,0)</i> Pe= NennLeistung [kW] (Bei Betriebsfaktor fs=1,0)						Güv. Rad.Yük Çıkış <i>Per.O.Loads (Output)</i>	Güv.Rad.Yük Giriş <i>Per.O.Loads (Input)</i>	Ağırlık <i>Weight</i> Gewicht [kg]	Ölçü Sayfası <i>Dim. Page</i> Maße Seite	Fiyat Kodu <i>Price Ref.</i> Preis No.
	Giriş devri[d/d] / Input speed[rpm] / Antriebsdrehzahl[upm]						Zul.Querkräfte (Abtrieb)	Zul.Querkräfte (Antrieb)	Fqam [N] (n1=1400rpm)	Fqem [N] (n1=1400rpm)				
	n1=2800	n1=1400		n1=900	n1=750	n1=450	n1=350							
<b>820</b>	15.96	88	<b>KT373</b>	14	<b>8.0</b>	5.2	4.3	2.6	2.0	11800	-	60	394	KT004
<b>820</b>	18.62	75		13	<b>6.9</b>	4.4	3.7	2.2	1.7	11800	-			
<b>820</b>	21.90	64		12	<b>5.8</b>	3.8	3.1	1.9	1.5	11800	-			
<b>820</b>	24.72	57		10	<b>5.2</b>	3.3	2.8	1.7	1.3	11800	1484			
<b>820</b>	28.85	49		8.9	<b>4.4</b>	2.9	2.4	1.4	1.1	11800	1529			
<b>820</b>	33.65	42		7.6	<b>3.8</b>	2.4	2.0	1.2	0.95	11800	1572			
<b>820</b>	37.19	38		6.9	<b>3.4</b>	2.2	1.8	1.1	0.86	11800	1595			
<b>820</b>	43.40	32		5.9	<b>3.0</b>	1.9	1.6	0.95	0.74	11800	1625			
<b>820</b>	51.05	27		5.0	<b>2.6</b>	1.6	1.3	0.81	0.63	11800	1652			
<b>820</b>	60.69	23		4.2	<b>2.1</b>	1.4	1.1	0.68	0.53	11800	1675			
<b>820</b>	68.65	20		3.7	<b>1.9</b>	1.2	1.0	0.60	0.47	11800	1690			
<b>820</b>	78.29	18		3.3	<b>1.6</b>	1.1	0.88	0.53	0.41	11800	1704			
<b>820</b>	97.26	14		2.6	<b>1.3</b>	0.85	0.70	0.42	0.33	11800	1723			
<b>820</b>	110.61	13		2.3	<b>1.2</b>	0.74	0.62	0.37	0.29	11800	1732			
<b>820</b>	127.30	11		2.0	<b>1.0</b>	0.65	0.54	0.32	0.25	11800	-			
<b>820</b>	148.75	9.4		1.7	<b>0.86</b>	0.55	0.46	0.28	0.24	11800	-			
<b>820</b>	127.14	11	<b>KT374</b>	2.1	<b>1.0</b>	0.67	0.56	0.33	0.26	11800	1317	61	398	KT005
<b>820</b>	140.49	10		1.9	<b>0.94</b>	0.60	0.50	0.30	0.26	11800	1241			
<b>820</b>	163.96	8.54		1.6	<b>0.81</b>	0.52	0.43	0.26	0.22	11800	1374			
<b>820</b>	192.86	7.26		1.4	<b>0.69</b>	0.44	0.37	0.24	0.19	11800	1403			
<b>820</b>	229.29	6.11		1.2	<b>0.58</b>	0.37	0.31	0.21	0.16	11800	1429			
<b>820</b>	259.36	5.40		1.0	<b>0.51</b>	0.33	0.27	0.18	0.14	11800	1445			
<b>820</b>	295.76	4.73		0.90	<b>0.45</b>	0.29	0.27	0.16	0.12	11800	1460			
<b>820</b>	367.43	3.81		0.72	<b>0.36</b>	0.26	0.22	0.13	0.10	11800	1481			
<b>820</b>	374.18	3.74	<b>KT375</b>	0.73	<b>0.36</b>	0.26	0.22	0.13	0.10	11800	927	62	402	KT006
<b>820</b>	442.71	3.16		0.61	<b>0.31</b>	0.22	0.18	0.11	0.09	11800	931			
<b>820</b>	473.96	2.95		0.57	<b>0.29</b>	0.20	0.17	0.10	0.08	11800	932			
<b>820</b>	536.75	2.61		0.51	<b>0.25</b>	0.18	0.15	0.09	0.07	11800	934			
<b>820</b>	593.11	2.36		0.51	<b>0.26</b>	0.18	0.15	0.09	0.07	11800	939			
<b>820</b>	692.22	2.02		0.44	<b>0.22</b>	0.16	0.13	0.08	0.06	11800	947			
<b>820</b>	814.20	1.72		0.37	<b>0.19</b>	0.13	0.11	0.07	0.05	11800	953			
<b>820</b>	968.01	1.4		0.31	<b>0.16</b>	0.11	0.09	0.06	0.04	11800	960			
<b>820</b>	1094.97	1.3		0.28	<b>0.14</b>	0.10	0.08	0.05	0.04	11800	963			
<b>820</b>	1184.90	1.2	<b>KT376</b>	0.26	<b>0.13</b>	0.09	0.08	0.05	0.04	11800	971	64	402	KT007
<b>820</b>	1401.91	1.0		0.25	<b>0.11</b>	0.08	0.07	0.04	0.03	11800	972			
<b>820</b>	1500.87	0.93		0.23	<b>0.10</b>	0.07	0.06	0.04	0.03	11800	973			
<b>820</b>	1699.70	0.82		0.20	<b>0.09</b>	0.07	0.05	0.03	0.03	11800	973			
<b>820</b>	1878.17	0.75		0.18	<b>0.08</b>	0.06	0.05	0.03	0.02	11800	975			
<b>820</b>	2192.03	0.64		0.16	<b>0.07</b>	0.05	0.04	0.03	0.02	11800	978			
<b>820</b>	2578.32	0.54		0.13	<b>0.06</b>	0.04	0.04	0.02	0.02	11800	980			
<b>820</b>	3065.37	0.46		0.11	<b>0.05</b>	0.04	0.03	0.02	0.01	11800	982			
<b>820</b>	3467.39	0.40		0.10	<b>0.04</b>	0.03	0.03	0.02	0.01	11800	983			
<b>830</b>	6.21	225	<b>KT473</b>	34	<b>21</b>	15	13	9.4	7.9	12444	-	96	406	KT008
<b>865</b>	7.48	187		29	<b>18</b>	13	11	8.1	6.8	13228	-			
<b>905</b>	9.06	154		25	<b>16</b>	11	9.5	7.0	5.9	14068	-			
<b>935</b>	10.34	135		23	<b>14</b>	10	8.6	6.4	5.4	14673	-			
<b>970</b>	11.87	118		21	<b>13</b>	9.3	7.8	5.8	4.8	15314	-			
<b>1005</b>	13.71	102		19	<b>11</b>	8.4	7.0	5.2	4.3	16035	-			
<b>1370</b>	15.33	91		23	<b>14</b>	10	8.5	5.1	3.9	16405	-			
<b>1425</b>	17.49	80		21	<b>13</b>	8.9	7.4	4.4	3.5	17070	-			
<b>1485</b>	20.07	70		19	<b>12</b>	7.7	6.5	3.9	3.0	17000	-			
<b>1550</b>	23.19	60		17	<b>10</b>	6.7	5.6	3.4	2.6	17000	-			
<b>1550</b>	23.76	59		17	<b>10</b>	6.5	5.5	3.3	2.5	17000	-			
<b>1550</b>	25.15	56		16	<b>9.7</b>	6.2	5.2	3.1	2.4	17000	-			
<b>1550</b>	30.11	46		14	<b>8.0</b>	5.1	4.3	2.6	2.0	17000	-			
<b>1550</b>	39.11	36		11	<b>6.2</b>	4.0	3.3	2.0	1.6	17000	1591			
<b>1550</b>	44.64	31		10	<b>5.4</b>	3.5	2.9	1.7	1.4	17000	1630			
<b>1550</b>	51.22	27		9.3	<b>4.7</b>	3.0	2.5	1.5	1.9	17000	1665			
<b>1550</b>	59.19	24		8.2	<b>4.1</b>	2.6	2.2	1.3	1.0	17000	1698			

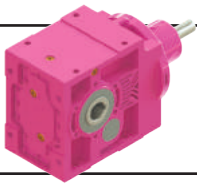

# K Serisi Motorsuz Güç Devir Sayfaları

## K Series Gear Units Performance Tables

### K Serien Getriebe Leistung und Drehzahlübersicht



Anma Momenti Nominal Torques Nenn-drehmomente Ma [Nm] (n1=1400rpm)	Çevrim Oranı Ratio Übersetzung i	Çıkış Devri Output Speeds Abtriebs-drehzahlen n2 [r.p.m] (n1=1400rpm)	Tipi Type Typ	Pe= Nominal Güç [kW] (Servis Faktörü fs=1,0 için) Pe= Nominal Power [kW] (For Service Factor fs=1,0) Pe= NennLeistung [kW] (Bei Betriebsfaktor fs=1,0)						Güv. Rad.Yük Çıkış Per.O.Loads (Output) Zul.Querkräfte (Abtrieb) Fqam [N] (n1=1400rpm)	Güv.Rad.Yük Giriş Per.O.Loads (Input) Zul.Querkräfte (Antrieb) Fqem [N] (n1=1400rpm)	Ağırlık Weight Gewicht [kg]	Ölçü Sayfası Dim. Page Maße Seite	Fiyat Kodu Price Ref. Preis No.
				Giriş devri[d/d] / Input speed[rpm] / Antriebsdrehzahl[upm]										
				n1=2800	n1=1400	n1=900	n1=750	n1=450	n1=350					
<b>1550</b>	60.63	23	<b>KT473</b>	8.0	<b>4.0</b>	2.6	2.1	1.3	1.0	17000	1704	96	406	KT008
<b>1550</b>	64.17	22		7.5	<b>3.8</b>	2.4	2.0	1.2	0.94	17000	1716			
<b>1550</b>	76.83	18		6.3	<b>3.2</b>	2.0	1.7	1.0	0.79	17000	1747			
<b>1550</b>	87.49	16		5.5	<b>2.8</b>	1.8	1.5	0.89	0.69	17000	1766			
<b>1550</b>	97.79	14		4.9	<b>2.5</b>	1.6	1.3	0.79	0.62	17000	1783			
<b>1550</b>	110.65	13		4.3	<b>2.2</b>	1.4	1.2	0.70	0.55	17000	1797			
<b>1550</b>	135.98	10		3.6	<b>1.8</b>	1.1	0.95	0.57	0.44	17000	1818			
<b>1550</b>	153.47	9.1		3.2	<b>1.6</b>	1.0	0.84	0.51	0.39	17000	1827			
<b>1550</b>	160.79	8.7	<b>KT474</b>	31	<b>1.5</b>	0.99	0.83	0.50	0.39	17000	1786	98	410	KT009
<b>1550</b>	181.88	7.7		2.7	<b>1.4</b>	0.88	0.73	0.44	0.34	17000	1797			
<b>1550</b>	207.41	6.7		2.4	<b>1.2</b>	0.77	0.64	0.39	0.30	17000	1806			
<b>1550</b>	257.67	5.4		1.9	<b>1.0</b>	0.62	0.52	0.31	0.27	17000	1816			
<b>1550</b>	293.03	4.8		1.7	<b>0.85</b>	0.55	0.46	0.27	0.24	17000	1827			
<b>1550</b>	310.16	4.5		1.6	<b>0.81</b>	0.52	0.43	0.26	0.22	17000	1837			
<b>1550</b>	371.35	3.8		1.4	<b>0.67</b>	0.43	0.36	0.24	0.19	17000	1874			
<b>1550</b>	422.88	3.3		1.2	<b>0.59</b>	0.38	0.32	0.21	0.16	17000	1896			
<b>1550</b>	472.63	3.0		1.0	<b>0.53</b>	0.34	0.28	0.19	0.15	17000	1912			
<b>1550</b>	509.34	2.7	<b>KT475</b>	1.0	<b>0.50</b>	0.32	0.27	0.18	0.14	17000	1504	101	414	KT010
<b>1550</b>	610.72	2.3		0.84	<b>0.42</b>	0.27	0.25	0.15	0.12	17000	1509			
<b>1550</b>	655.16	2.1		0.78	<b>0.39</b>	0.25	0.23	0.14	0.11	17000	1510			
<b>1550</b>	738.55	1.9		0.69	<b>0.35</b>	0.25	0.21	0.12	0.10	17000	1513			
<b>1550</b>	844.06	1.7		0.61	<b>0.30</b>	0.22	0.18	0.11	0.08	17000	1516			
<b>1550</b>	901.03	1.6		0.57	<b>0.29</b>	0.20	0.17	0.10	0.08	17000	1517			
<b>1550</b>	971.77	1.4		0.53	<b>0.26</b>	0.19	0.16	0.09	0.07	17000	1519			
<b>1550</b>	1142.99	1.2		0.50	<b>0.25</b>	0.18	0.15	0.09	0.07	17000	1521			
<b>1550</b>	1218.61	1.1		0.47	<b>0.24</b>	0.17	0.14	0.08	0.07	17000	1522			
<b>1550</b>	1395.04	1.0		0.41	<b>0.21</b>	0.15	0.12	0.07	0.06	17000	1524			
<b>1550</b>	1476.60	0.95		0.39	<b>0.19</b>	0.14	0.12	0.07	0.05	17000	1526			
<b>1550</b>	1767.90	0.79		0.33	<b>0.16</b>	0.12	0.10	0.06	0.05	17000	1533			
<b>1550</b>	2183.54	0.64	<b>KT476</b>	0.27	<b>0.13</b>	0.10	0.08	0.05	0.04	17000	1550	104	414	KT011
<b>1550</b>	2495.47	0.56		0.26	<b>0.12</b>	0.08	0.07	0.04	0.03	17000	1551			
<b>1550</b>	2663.91	0.53		0.24	<b>0.11</b>	0.08	0.07	0.04	0.03	17000	1551			
<b>1550</b>	2873.07	0.49		0.23	<b>0.10</b>	0.07	0.06	0.04	0.03	17000	1551			
<b>1550</b>	3379.28	0.41		0.19	<b>0.09</b>	0.06	0.05	0.03	0.02	17000	1552			
<b>1550</b>	3602.83	0.39		0.18	<b>0.08</b>	0.06	0.05	0.03	0.02	17000	1552			
<b>1550</b>	4124.46	0.34		0.16	<b>0.07</b>	0.05	0.04	0.03	0.02	17000	1553			
<b>1550</b>	4365.60	0.32		0.15	<b>0.07</b>	0.05	0.04	0.02	0.02	17000	1554			
<b>1550</b>	5226.85	0.27		0.13	<b>0.06</b>	0.04	0.03	0.02	0.02	17000	1556			
<b>1220</b>	6.91	203	<b>KT573</b>	-	<b>28</b>	20	18	12	10	19926	-	138	418	KT012
<b>1300</b>	8.07	173		-	<b>25</b>	21	16	11	9.3	20771	-			
<b>1380</b>	9.48	148		37	<b>23</b>	17	15	10	8.6	21719	-			
<b>1470</b>	11.22	125		33	<b>20</b>	15	13	9.2	7.8	22753	-			
<b>1700</b>	11.58	121		-	<b>23</b>	17	15	10	8.7	22685	-			
<b>1820</b>	13.53	104		-	<b>21</b>	15	14	9.5	7.8	23595	-			
<b>1930</b>	15.88	88		31	<b>19</b>	14	13	8.5	6.6	24671	-			
<b>2050</b>	18.80	74		28	<b>17</b>	13	11	7.2	5.6	25860	-			
<b>2100</b>	20.24	69		27	<b>16</b>	12	11	6.7	5.2	26421	-			
<b>2200</b>	22.77	61		25	<b>15</b>	11	9.8	5.9	4.6	27263	-			
<b>2300</b>	25.78	54		23	<b>14</b>	10	8.8	5.3	4.1	28225	-			
<b>2300</b>	30.25	46		-	<b>12</b>	8.7	7.5	4.5	3.5	29000	2812			
<b>2430</b>	35.34	40		-	<b>11</b>	7.7	6.4	3.8	3.0	27500	2834			
<b>2500</b>	38.16	37		17	<b>10</b>	7.1	5.9	3.6	2.8	26000	2865			
<b>2620</b>	44.73	31		15	<b>9.1</b>	6.1	5.0	3.0	2.4	24500	2886			
<b>2700</b>	52.88	26		13	<b>8.0</b>	5.1	4.3	2.6	2.0	22500	2919			
<b>2700</b>	59.49	24		12	<b>7.1</b>	4.6	3.8	2.3	1.8	22500	2954			
<b>2700</b>	67.37	21		11	<b>6.3</b>	4.0	3.4	2.0	1.6	22500	2988			
<b>2700</b>	82.14	17		9.9	<b>5.1</b>	3.3	2.8	1.7	1.3	22500	3031			
<b>2700</b>	97.19	14		8.7	<b>4.3</b>	2.8	2.3	1.4	1.1	22500	3063			
<b>2700</b>	109.86	13		7.7	<b>3.8</b>	2.5	2.1	1.2	0.96	22500	3083			

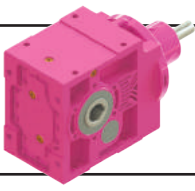

# K Serisi Motorsuz Güç Devir Sayfaları

## K Series Gear Units Performance Tables

### K Serien Getriebe Leistung und Drehzahlübersicht



Anma Momenti Nominal Torques Nenn-drehmomente Ma [Nm] (n1=1400rpm)	Çevrim Oranı Ratio Übersetzung i	Çıkış Devri Output Speeds Abtriebs-drehzahlen n2 [r.p.m] (n1=1400rpm)	Tipi Type Typ	Pe= Nominal Güç [kW] (Servis Faktörü fs=1,0 için) Pe= Nominal Power [kW] (For Service Factor fs=1,0) Pe= NennLeistung [kW] (Bei Betriebsfaktor fs=1,0)						Güv. Rad.Yük Çıkış Per.O.Loads (Output) Zul.Querkräfte (Abtrieb) Fqam [N] (n1=1400rpm)	Güv.Rad.Yük Giriş Per.O.Loads (Input) Zul.Querkräfte (Antrieb) Fqem [N] (n1=1400rpm)	Ağırlık Weight Gewicht [kg]	Ölçü Sayfası Dim. Page Maße Seite	Fiyat Kodu Price Ref. Preis No.
				Giriş devri[d/d] / Input speed[rpm] / Antriebsdrehzahl[upm]										
				n1=2800	n1=1400	n1=900	n1=750	n1=450	n1=350					
<b>2700</b>	125.51	11	<b>KT573</b>	6.7	<b>3.4</b>	2.2	1.8	1.1	0.84	22500	3102	138	418	KT012
<b>2700</b>	117.96	12	<b>KT574</b>	7.3	<b>3.7</b>	2.4	2.0	1.2	0.91	22500	1500	140	422	KT013
<b>2700</b>	140.24	10		6.2	<b>3.1</b>	2.0	1.7	0.99	0.77	22500	1533			
<b>2700</b>	158.64	8.83		5.5	<b>2.7</b>	1.8	1.5	0.88	0.68	22500	1553			
<b>2700</b>	180.90	7.74		4.8	<b>2.4</b>	1.5	1.3	0.77	0.60	22500	1572			
<b>2700</b>	211.51	6.62		4.1	<b>2.1</b>	1.3	1.1	0.66	0.51	22500	1592			
<b>2700</b>	237.97	5.88		3.7	<b>1.8</b>	1.2	0.98	0.59	0.46	22500	1643			
<b>2700</b>	246.42	5.68		3.5	<b>1.8</b>	1.1	0.94	0.57	0.44	22500	1731			
<b>2700</b>	281.00	4.98		3.1	<b>1.6</b>	0.99	0.83	0.50	0.39	22500	1743			
<b>2700</b>	328.56	4.26		2.7	<b>1.3</b>	0.85	0.71	0.43	0.33	22500	1756			
<b>2700</b>	397.01	3.53		2.2	<b>1.1</b>	0.71	0.59	0.35	0.27	22500	1769			
<b>2700</b>	469.74	2.98		1.9	<b>0.93</b>	0.60	0.50	0.30	0.26	22500	1813			
<b>2700</b>	507.09	2.76	<b>KT575</b>	1.8	<b>0.88</b>	0.57	0.47	0.28	0.25	22500	1356	140	426	KT014
<b>2700</b>	570.53	2.45		1.6	<b>0.78</b>	0.50	0.42	0.25	0.22	22500	1380			
<b>2700</b>	787.70	1.78		1.1	<b>0.57</b>	0.37	0.30	0.20	0.16	22500	1431			
<b>2700</b>	932.00	1.50		0.96	<b>0.48</b>	0.31	0.26	0.17	0.13	22500	1453			
<b>2700</b>	1216.74	1.2		0.74	<b>0.37</b>	0.26	0.22	0.13	0.10	22500	1478			
<b>2700</b>	1368.95	1.0		0.66	<b>0.33</b>	0.23	0.20	0.12	0.09	22500	1488			
<b>2700</b>	1890.04	0.74		0.53	<b>0.26</b>	0.19	0.16	0.09	0.07	22500	1510			
<b>2700</b>	2236.28	0.63		0.45	<b>0.22</b>	0.16	0.13	0.08	0.06	22500	1519			
<b>2700</b>	2328.84	0.60	<b>KT576</b>	0.44	<b>0.22</b>	0.16	0.13	0.08	0.06	22500	1523	145	426	KT015
<b>2700</b>	2755.47	0.51		0.37	<b>0.19</b>	0.13	0.11	0.07	0.05	22500	1530			
<b>2700</b>	3597.31	0.39		0.28	<b>0.14</b>	0.10	0.08	0.05	0.04	22500	1538			
<b>2700</b>	4047.32	0.35		0.25	<b>0.13</b>	0.09	0.08	0.05	0.04	22500	1541			
<b>2700</b>	5587.93	0.25		0.20	<b>0.09</b>	0.07	0.05	0.03	0.03	22500	1549			
<b>2700</b>	6611.61	0.21		0.17	<b>0.08</b>	0.06	0.05	0.03	0.02	22500	1552			
<b>2500</b>	8.31	169	<b>KT673</b>	-	<b>47</b>	35	31	21	17.8	25155	-	235	430	KT016
<b>2600</b>	9.45	148		-	<b>43</b>	31	28	19	15.7	26140	-			
<b>2700</b>	10.81	130		-	<b>39</b>	29	25	18	13.7	27248	-			
<b>2800</b>	12.46	112		56	<b>35</b>	26	23	15	11.9	28510	-			
<b>2900</b>	14.49	97		51	<b>31</b>	23	20	13	10.2	29970	-			
<b>4300</b>	16.54	85		-	<b>41</b>	26	22	13	10.1	26490	-			
<b>4300</b>	18.74	75		-	<b>36</b>	23	19	12	9.0	28202	-			
<b>4300</b>	21.32	66		-	<b>31</b>	20	17	10	7.9	29600	-			
<b>4300</b>	24.38	57		-	<b>28</b>	18	15	8.8	6.9	29600	-			
<b>4300</b>	28.10	50		48	<b>24</b>	15	13	7.7	6.0	29600	-			
<b>4300</b>	32.68	43		41	<b>21</b>	13	11	6.6	5.1	29600	-			
<b>4300</b>	39.26	36		-	<b>17</b>	11	9.2	5.5	4.3	29600	3205			
<b>4300</b>	44.65	31		-	<b>15</b>	9.7	8.1	4.8	3.8	29600	3276			
<b>4300</b>	51.08	27		-	<b>13</b>	8.4	7.0	4.2	3.3	29600	3340			
<b>4300</b>	58.86	24		23	<b>11</b>	7.3	6.1	3.7	2.9	29600	3400			
<b>4300</b>	68.47	20		20	<b>9.8</b>	6.3	5.3	3.2	2.5	29600	3454			
<b>4300</b>	80.38	17		17	<b>8.3</b>	5.4	4.5	2.7	2.1	29600	3520			
<b>4300</b>	90.21	16		15	<b>7.4</b>	4.8	4.0	2.4	1.9	29600	3551			
<b>4300</b>	100.90	14		13	<b>6.7</b>	4.3	3.6	2.1	1.7	29600	3569			
<b>4300</b>	128.24	11		10	<b>5.2</b>	3.4	2.8	1.7	1.3	29600	3626			
<b>4300</b>	123.38	11	<b>KT674</b>	11	<b>5.6</b>	3.6	3.0	1.8	1.4	29600	687	238	434	KT017
<b>4300</b>	140.49	10		9.8	<b>4.9</b>	3.1	2.6	1.6	1.2	29600	808			
<b>4300</b>	157.02	8.9		8.7	<b>4.4</b>	2.8	2.3	1.4	1.1	29600	920			
<b>4300</b>	178.62	7.8		7.7	<b>3.9</b>	2.5	2.1	1.2	0.96	29600	1342			
<b>4300</b>	204.32	6.9		6.7	<b>3.4</b>	2.2	1.8	1.1	0.84	29600	1616			
<b>4300</b>	235.44	5.9		5.9	<b>2.9</b>	1.9	1.6	0.94	0.73	29600	1702			
<b>4300</b>	273.88	5.1		5.0	<b>2.5</b>	1.6	1.4	0.81	0.63	29600	1781			
<b>4300</b>	321.51	4.4		4.3	<b>2.1</b>	1.4	1.2	0.69	0.54	29600	1853			
<b>4300</b>	363.81	3.8		3.8	<b>1.9</b>	1.2	1.0	0.61	0.47	29600	1865			

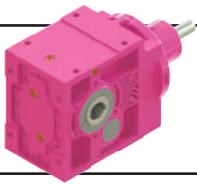

# K Serisi Motorsuz Güç Devir Sayfaları

## K Series Gear Units Performance Tables

### K Serien Getriebe Leistung und Drehzahlübersicht



Anma Momenti Nominal Torques Nenn-drehmomente Ma [Nm] (n1=1400rpm)	Çevrim Oranı Ratio Übersetzung i	Çıkış Devri Output Speeds Abtriebs-drehzahlen n2 [r.p.m] (n1=1400rpm)	Tipi Type Typ	Pe= Nominal Güç [kW] (Servis Faktörü fs=1,0 için) Pe= Nominal Power [kW] (For Service Factor fs=1,0) Pe= NennLeistung [kW] (Bei Betriebsfaktor fs=1,0)						Güv. Rad.Yük Çıkış Per.O.Loads (Output) Zul.Querkräfte (Abtrieb) Fqam [N] (n1=1400rpm)	Güv.Rad.Yük Giriş Per.O.Loads (Input) Zul.Querkräfte (Antrieb) Fqem [N] (n1=1400rpm)	Ağırlık Weight Gewicht [kg]	Ölçü Sayfası Dim. Page Maße Seite	Fiyat Kodu Price Ref. Preis No.
				Giriş devri[d/d] / Input speed[rpm] / Antriebsdrehzahl[upm]										
				n1=2800	n1=1400	n1=900	n1=750	n1=450	n1=350					
<b>4300</b>	423.90	3.3	<b>KT675</b>	3.3	<b>1.7</b>	1.1	0.89	0.53	0.42	29600	1852	243	438	KT018
<b>4300</b>	489.82	2.9		2.9	<b>1.4</b>	0.93	0.77	0.46	0.36	29600	1863			
<b>4300</b>	531.08	2.6		2.7	<b>1.3</b>	0.85	0.71	0.43	0.33	29600	1869			
<b>4300</b>	635.86	2.2		2.2	<b>1.1</b>	0.72	0.60	0.36	0.28	29600	1880			
<b>4300</b>	724.08	1.9		2.0	<b>0.98</b>	0.63	0.52	0.31	0.27	29600	1886			
<b>4300</b>	809.27	1.7		1.8	<b>0.88</b>	0.56	0.47	0.28	0.24	29600	1892			
<b>4300</b>	915.75	1.5		1.6	<b>0.78</b>	0.50	0.42	0.28	0.22	29600	1897			
<b>4300</b>	1041.68	1.3		1.4	<b>0.68</b>	0.44	0.37	0.24	0.19	29600	1916			
<b>4300</b>	1191.60	1.2		1.2	<b>0.60</b>	0.38	0.32	0.21	0.17	29600	1933			
<b>4300</b>	1373.07	1.0		1.0	<b>0.52</b>	0.33	0.28	0.19	0.14	29600	1949			
<b>4300</b>	1597.25	0.88		0.89	<b>0.45</b>	0.29	0.27	0.16	0.12	29600	1963			
<b>4300</b>	1875.03	0.75		0.76	<b>0.38</b>	0.27	0.23	0.14	0.11	29600	1977			
<b>4300</b>	1884.33	0.74	<b>KT676</b>	0.77	<b>0.39</b>	0.28	0.23	0.14	0.11	29600	2009	250	438	KT019
<b>4300</b>	2082.19	0.67		0.70	<b>0.35</b>	0.25	0.21	0.12	0.10	29600	2011			
<b>4300</b>	2430.14	0.58		0.60	<b>0.30</b>	0.21	0.18	0.11	0.08	29600	2014			
<b>4300</b>	2858.39	0.49		0.51	<b>0.26</b>	0.18	0.15	0.09	0.07	29600	2016			
<b>4300</b>	3398.35	0.41		0.48	<b>0.24</b>	0.17	0.14	0.09	0.07	29600	2018			
<b>4300</b>	3844.04	0.36		0.42	<b>0.21</b>	0.15	0.13	0.08	0.06	29600	2020			
<b>4300</b>	4383.55	0.32		0.37	<b>0.19</b>	0.13	0.11	0.07	0.05	29600	2021			
<b>4300</b>	5445.72	0.26		0.30	<b>0.15</b>	0.11	0.09	0.05	0.04	29600	2023			
<b>4300</b>	6193.17	0.23		0.26	<b>0.13</b>	0.09	0.08	0.05	0.04	29600	2024			
<b>4300</b>	7044.81	0.20		0.26	<b>0.12</b>	0.08	0.07	0.04	0.03	29600	2027			
<b>4300</b>	8058.67	0.17		0.23	<b>0.10</b>	0.07	0.06	0.04	0.03	29600	2030			
<b>4300</b>	9285.97	0.15		0.20	<b>0.09</b>	0.06	0.05	0.03	0.02	29600	2033			
<b>4300</b>	10802.05	0.13		0.17	<b>0.08</b>	0.05	0.05	0.03	0.02	29600	2036			
<b>4300</b>	12680.66	0.11		0.14	<b>0.06</b>	0.05	0.04	0.02	0.02	29600	2038			
<b>3900</b>	7.41	189	<b>KT773</b>	-	<b>77</b>	60	53	37	31	34068	-	360	442	KT020
<b>4050</b>	8.52	164		-	<b>70</b>	54	48	34	27	35582	-			
<b>4200</b>	9.83	142		-	<b>63</b>	49	43	30	23	37261	-			
<b>4250</b>	10.20	137		-	<b>61</b>	48	42	29	22	37654	-			
<b>4400</b>	11.44	122		-	<b>56</b>	44	39	25	20	38968	-			
<b>4500</b>	12.89	109		-	<b>51</b>	40	35	23	18	40635	-			
<b>7250</b>	15.25	92		-	<b>70</b>	53	44	26	20	37126	-			
<b>7550</b>	17.52	80		-	<b>63</b>	46	38	23	18	38736	-			
<b>7900</b>	20.23	69		-	<b>57</b>	40	33	20	15	40382	-			
<b>8000</b>	20.97	67		-	<b>56</b>	38	32	19	15	40780	-			
<b>8000</b>	23.52	60		-	<b>50</b>	34	28	17	13	43151	-			
<b>8000</b>	26.52	53		-	<b>44</b>	30	25	15	12	45714	-			
<b>8000</b>	29.40	48		-	<b>40</b>	27	23	14	11	47999	2086			
<b>8000</b>	33.78	41		-	<b>35</b>	24	20	12	9.2	51188	2708			
<b>8000</b>	39.00	36		-	<b>30</b>	21	17	10	8.0	54628	3265			
<b>8000</b>	40.44	35		-	<b>29</b>	20	16	9.9	7.7	55522	3286			
<b>8000</b>	45.36	31		-	<b>26</b>	18	15	8.8	6.9	55500	3666			
<b>8000</b>	51.13	27		-	<b>23</b>	16	13	7.8	6.1	55500	4019			
<b>8000</b>	58.00	24		-	<b>20</b>	14	12	6.9	5.4	55500	4208			
<b>8000</b>	66.32	21		38	<b>18</b>	12	10	6.1	4.7	55500	4284			
<b>8000</b>	76.59	18		33	<b>15</b>	10	8.7	5.2	4.1	55500	4355			
<b>8000</b>	88.57	16		28	<b>13</b>	9	7.6	4.5	3.5	55500	4434			
<b>8000</b>	99.00	14		25	<b>12</b>	8.1	6.8	4.1	3.2	55500	4475			
<b>8000</b>	111.63	13		22	<b>11</b>	7.2	6.0	3.6	2.8	55500	4515			
<b>8000</b>	127.11	11	<b>KT774</b>	20	<b>10</b>	6.4	5.4	3.2	2.5	55000	-	370	446	KT021
<b>8000</b>	142.56	10		18	<b>8.9</b>	5.7	4.8	2.9	2.2	55000	-			
<b>8000</b>	160.70	8.7		16	<b>7.9</b>	5.1	4.2	2.5	2.0	55000	-			
<b>8000</b>	182.29	7.7		14	<b>7.0</b>	4.5	3.7	2.2	1.8	55000	-			
<b>8000</b>	208.42	6.7		12	<b>6.1</b>	3.9	3.3	2.0	1.5	55000	326			
<b>8000</b>	240.71	5.8		11	<b>5.3</b>	3.4	2.8	1.7	1.3	55000	874			
<b>8000</b>	278.35	5.0		9.2	<b>4.6</b>	3.0	2.5	1.5	1.2	55000	1351			
<b>8000</b>	311.14	4.5		8.2	<b>4.1</b>	2.6	2.2	1.3	1.0	55000	1601			
<b>8000</b>	354.32	4.0		7.2	<b>3.6</b>	2.3	1.9	1.2	0.90	55000	1625			
<b>8000</b>	396.00	3.5		6.5	<b>3.2</b>	2.1	1.7	1.0	0.81	55000	1647			

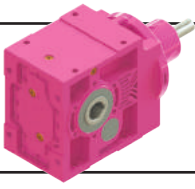

# K Serisi Motorsuz Güç Devir Sayfaları

## K Series Gear Units Performance Tables

### K Serien Getriebe Leistung und Drehzahlübersicht



Anma Momenti <i>Nominal Torques</i> Nenn-drehmomente Ma [Nm] (n1=1400rpm)	Çevrim Oranı	Çıkış Devri	Tipi	Pe= Nominal Güç [kW] (Servis Faktörü fs=1,0 için)						Güv. Rad.Yük Çıkış <i>Per.O.Loads (Output)</i>	Güv.Rad.Yük Giriş <i>Per.O.Loads (Input)</i>	Ağırlık <i>Weight</i>	Ölçü Sayfası <i>Dim. Page</i>	Fiyat Kodu <i>Price Ref.</i>
	Ratio	Output Speeds		Type	Pe= NennLeistung [kW] (Bei Betriebsfaktor fs=1,0)									
	Übersetzung	Abtriebs-drehzahlen	Typ	Giriş devri[d/d] / Input speed[rpm] / Antriebsdrehzahl[upm]						Zul.Querkräfte (Abtrieb)	Zul.Querkräfte (Antrieb)	Gewicht	Maße Seite	Preis No.
	i	n2 [r.p.m] (n1=1400rpm)	n1=2800	n1=1400	n1=900	n1=750	n1=450	n1=350	Fqam [N] (n1=1400rpm)					
<b>8000</b>	436.74	3.2	<b>KT775</b>	6.0	<b>3.0</b>	1.9	1.6	0.96	0.75	55000	1686	381	450	KT022
<b>8000</b>	504.65	2.8		5.2	<b>2.6</b>	1.7	1.4	0.83	0.65	55000	1706			
<b>8000</b>	547.17	2.6		4.8	<b>2.4</b>	1.5	1.3	0.77	0.60	55000	1717			
<b>8000</b>	655.11	2.1		4.0	<b>2.0</b>	1.3	1.1	0.64	0.50	55000	1737			
<b>8000</b>	746.01	1.9		3.5	<b>1.8</b>	1.1	0.94	0.57	0.44	55000	1749			
<b>8000</b>	833.78	1.7		3.2	<b>1.6</b>	1.0	0.85	0.51	0.39	55000	1759			
<b>8000</b>	943.49	1.5		2.8	<b>1.4</b>	0.90	0.75	0.45	0.35	55000	1768			
<b>8000</b>	1058.16	1.3		2.5	<b>1.3</b>	0.80	0.67	0.40	0.31	55000	1799			
<b>8000</b>	1192.77	1.2		2.2	<b>1.1</b>	0.71	0.59	0.36	0.28	55000	1827			
<b>8000</b>	1353.02	1.0		2.0	<b>0.98</b>	0.63	0.52	0.31	0.27	55000	1854			
<b>8000</b>	1547.01	0.90		1.7	<b>0.85</b>	0.55	0.46	0.27	0.24	55000	1879			
<b>8000</b>	1786.65	0.78		1.5	<b>0.74</b>	0.48	0.40	0.26	0.21	55000	1902			
<b>8000</b>	2066.04	0.68		1.3	<b>0.64</b>	0.41	0.34	0.23	0.18	55000	1923			
<b>8000</b>	2539.01	0.55		1.0	<b>0.52</b>	0.34	0.28	0.19	0.14	55000	1928			
<b>8000</b>	2838.16	0.49		0.93	<b>0.47</b>	0.30	0.25	0.17	0.13	55000	1941			
<b>8000</b>	3203.12	0.44		0.83	<b>0.41</b>	0.27	0.25	0.15	0.11	55000	1944			
<b>8000</b>	1941.39	0.72	<b>KT776</b>	1.4	<b>0.69</b>	0.45	0.37	0.25	0.19	55000	1974	386	450	KT023
<b>8000</b>	2145.24	0.65		1.3	<b>0.63</b>	0.40	0.34	0.22	0.17	55000	1978			
<b>8000</b>	2503.73	0.56		1.1	<b>0.54</b>	0.35	0.29	0.19	0.15	55000	1983			
<b>8000</b>	2944.95	0.48		0.92	<b>0.46</b>	0.30	0.27	0.16	0.13	55000	1987			
<b>8000</b>	3501.26	0.40		0.77	<b>0.39</b>	0.28	0.23	0.14	0.11	55000	1991			
<b>8000</b>	3960.44	0.35		0.69	<b>0.34</b>	0.24	0.20	0.12	0.10	55000	1993			
<b>8000</b>	4516.30	0.31		0.60	<b>0.30</b>	0.22	0.18	0.11	0.08	55000	1996			
<b>8000</b>	5610.63	0.25		0.54	<b>0.27</b>	0.19	0.16	0.10	0.07	55000	1999			
<b>8000</b>	6380.72	0.22		0.47	<b>0.24</b>	0.17	0.14	0.08	0.07	55000	2000			
<b>8000</b>	7156.22	0.20		0.42	<b>0.21</b>	0.15	0.13	0.08	0.06	55000	2006			
<b>8000</b>	8066.59	0.17		0.38	<b>0.19</b>	0.13	0.11	0.07	0.05	55000	2011			
<b>8000</b>	9150.37	0.15		0.33	<b>0.17</b>	0.12	0.10	0.06	0.05	55000	2016			
<b>8000</b>	10462.31	0.13		0.29	<b>0.15</b>	0.10	0.09	0.05	0.04	55000	2021			
<b>8000</b>	12082.94	0.12		0.25	<b>0.13</b>	0.09	0.07	0.04	0.03	55000	2025			
<b>8000</b>	13972.49	0.10		0.24	<b>0.11</b>	0.08	0.06	0.04	0.03	55000	2029			
<b>8000</b>	15618.73	0.09		0.22	<b>0.10</b>	0.07	0.06	0.03	0.03	55000	2031			
<b>7850</b>	9.63	145	<b>KT873</b>	-	<b>127</b>	93	80	48	37	60190	-	615	454	KT024
<b>8100</b>	11.05	127		-	<b>114</b>	83	70	42	32	62966	-			
<b>8350</b>	12.25	114		-	<b>106</b>	75	63	38	29	64949	-			
<b>8650</b>	13.93	101		-	<b>97</b>	66	55	33	26	67591	-			
<b>12600</b>	16.78	83		-	<b>117</b>	86	75	45	35	65717	-			
<b>13100</b>	19.26	73		-	<b>106</b>	78	65	39	30	68567	-			
<b>13550</b>	21.34	66		-	<b>99</b>	70	59	35	27	70611	-			
<b>14100</b>	24.28	58		-	<b>91</b>	62	52	31	24	73348	-			
<b>13300</b>	29.88	47		-	<b>69</b>	50	42	25	20	82509	-			
<b>13800</b>	34.28	41		-	<b>63</b>	44	37	22	17	86143	-			
<b>14250</b>	38.00	37		-	<b>58</b>	40	33	20	15	83500	-			
<b>14750</b>	43.22	32		-	<b>53</b>	35	29	17	14	79500	-			
<b>15000</b>	49.75	28		-	<b>47</b>	30	25	15	12	76000	-			
<b>15000</b>	55.53	25		-	<b>42</b>	27	23	14	11	76000	-			
<b>15000</b>	62.42	22		-	<b>37</b>	24	20	12	9.4	76000	-			
<b>15000</b>	70.76	20		61	<b>33</b>	21	18	11	8.3	76000	266			
<b>15000</b>	81.06	17	55	<b>29</b>	19	15	9.3	7.2	76000	1059				
<b>15000</b>	92.80	15	50	<b>25</b>	16	14	8.1	6.3	76000	1618				
<b>15000</b>	103.24	14	45	<b>23</b>	15	12	7.3	5.7	76000	2100				
<b>15000</b>	115.87	12	40	<b>20</b>	13	11	6.5	5.1	76000	2567				
<b>15000</b>	86.63	16	<b>KT874</b>	55	<b>27</b>	18	15	8.8	6.8	76000	-	630	458	KT025
<b>15000</b>	98.53	14		48	<b>24</b>	15	13	7.7	6.0	76000	-			
<b>15000</b>	113.42	12		42	<b>21</b>	13	11	6.7	5.2	76000	-			
<b>15000</b>	126.62	11		37	<b>19</b>	12	10	6.0	4.7	76000	-			
<b>15000</b>	142.32	10		33	<b>17</b>	11	8.9	5.4	4.2	76000	466			
<b>15000</b>	161.34	8.7		29	<b>15</b>	9.5	7.9	4.7	3.7	76000	1260			
<b>15000</b>	184.83	7.6		26	<b>13</b>	8.3	6.9	4.1	3.2	76000	2069			
<b>15000</b>	207.95	6.7		23	<b>11</b>	7.4	6.1	3.7	2.9	76000	2278			
<b>15000</b>	235.47	5.9		20	<b>10</b>	6.5	5.4	3.3	2.5	76000	2474			

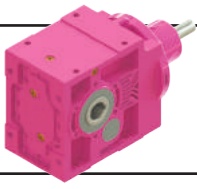

# K Serisi Motorsuz Güç Devir Sayfaları

## K Series Gear Units Performance Tables

### K Serien Getriebe Leistung und Drehzahlübersicht



Anma Momenti Nominal Torques Nenn-drehmomente Ma [Nm] (n1=1400rpm)	Çevrim Oranı Ratio Übersetzung i	Çıkış Devri Output Speeds Abtriebs-drehzahlen n2 [r.p.m] (n1=1400rpm)	Tipi Type Typ	Pe= Nominal Güç [kW] (Servis Faktörü fs=1,0 için) Pe= Nominal Power [kW] (For Service Factor fs=1,0) Pe= NennLeistung [kW] (Bei Betriebsfaktor fs=1,0)						Güv. Rad.Yük Çıkış Per.O.Loads (Output) Zul.Querkräfte (Abtrieb) Fqam [N] (n1=1400rpm)	Güv.Rad.Yük Giriş Per.O.Loads (Input) Zul.Querkräfte (Antrieb) Fqem [N] (n1=1400rpm)	Ağırlık Weight Gewicht [kg]	Ölçü Sayfası Dim. Page Maße Seite	Fiyat Kodu Price Ref. Preis No.
				Giriş devri[d/d] / Input speed[rpm] / Antriebsdrehzahl[upm]										
				n1=2800	n1=1400	n1=900	n1=750	n1=450	n1=350					
<b>15000</b>	287.10	4.9	<b>KT874</b>	17	<b>8.3</b>	5.4	4.5	2.7	2.1	76000	2653	630	458	KT025
<b>15000</b>	339.70	4.1		14	<b>7.1</b>	4.5	3.8	2.3	1.8	76000	2702			
<b>15000</b>	383.99	3.6		12	<b>6.2</b>	4.0	3.4	2.0	1.6	76000	2732			
<b>15000</b>	438.70	3.2		11	<b>5.5</b>	3.5	2.9	1.8	1.4	76000	2761			
<b>15000</b>	463.83	3.0	<b>KT875</b>	11	<b>5.3</b>	3.4	2.8	1.7	1.3	76000	-	640	462	KT026
<b>15000</b>	514.05	2.7		9.5	<b>4.8</b>	3.1	2.6	1.5	1.2	76000	-			
<b>15000</b>	584.66	2.4		8.4	<b>4.2</b>	2.7	2.3	1.4	1.1	76000	-			
<b>15000</b>	673.01	2.1		7.3	<b>3.6</b>	2.3	2.0	1.20	0.91	76000	-			
<b>15000</b>	751.30	1.9		6.5	<b>3.3</b>	2.1	1.8	1.1	0.82	76000	-			
<b>15000</b>	844.51	1.7		5.8	<b>2.9</b>	1.9	1.6	0.93	0.73	76000	-			
<b>15000</b>	957.34	1.5		5.1	<b>2.6</b>	1.7	1.4	0.83	0.64	76000	-			
<b>15000</b>	1096.71	1.3		4.5	<b>2.2</b>	1.4	1.2	0.72	0.56	76000	-			
<b>15000</b>	1313.07	1.1		3.8	<b>1.9</b>	1.2	1.0	0.60	0.47	76000	-			
<b>15000</b>	1495.27	0.94		3.3	<b>1.7</b>	1.1	0.89	0.53	0.41	76000	-			
<b>15000</b>	1671.18	0.84		3.0	<b>1.5</b>	0.95	0.79	0.48	0.37	76000	-			
<b>15000</b>	1891.08	0.74		2.6	<b>1.3</b>	0.84	0.70	0.42	0.33	76000	-			
<b>15000</b>	2074.42	0.67	<b>KT876</b>	2.4	<b>1.2</b>	0.78	0.65	0.39	0.30	76000	1922	650	462	KT027
<b>15000</b>	2387.89	0.59		2.1	<b>1.1</b>	0.68	0.57	0.34	0.26	76000	1939			
<b>15000</b>	2665.68	0.53		1.9	<b>0.95</b>	0.61	0.51	0.30	0.26	76000	1951			
<b>15000</b>	2996.39	0.47		1.7	<b>0.84</b>	0.54	0.45	0.27	0.23	76000	1962			
<b>15000</b>	3396.71	0.41		1.5	<b>0.74</b>	0.48	0.40	0.27	0.21	76000	1973			
<b>15000</b>	3891.23	0.36		1.3	<b>0.65</b>	0.42	0.35	0.23	0.18	76000	1983			
<b>15000</b>	4299.81	0.33		1.2	<b>0.59</b>	0.38	0.32	0.21	0.16	76000	1986			
<b>15000</b>	5018.35	0.28		1.0	<b>0.51</b>	0.32	0.27	0.18	0.14	76000	1990			
<b>15000</b>	5902.70	0.24		0.86	<b>0.43</b>	0.28	0.26	0.15	0.12	76000	1994			
<b>15000</b>	7017.76	0.20		0.73	<b>0.36</b>	0.26	0.22	0.13	0.10	76000	1998			
<b>15000</b>	7938.12	0.18		0.64	<b>0.32</b>	0.23	0.19	0.11	0.09	76000	2000			
<b>15000</b>	9052.24	0.15		0.56	<b>0.28</b>	0.20	0.17	0.10	0.08	76000	2002			
<b>15000</b>	11245.67	0.12		0.50	<b>0.25</b>	0.18	0.15	0.09	0.07	76000	2005			
<b>15000</b>	12789.19	0.11		0.44	<b>0.22</b>	0.16	0.13	0.08	0.06	76000	2006			



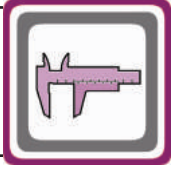
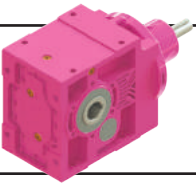

# Ölçü Sayfaları

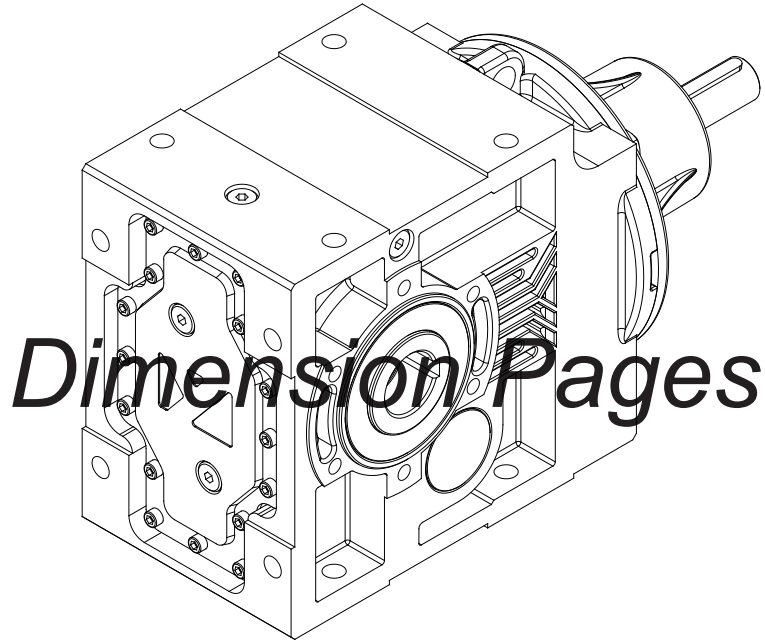

*Dimension Pages*

Abmessungenseiten

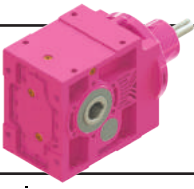

# Ölçü Sayfaları

## Dimension Pages

### Abmessungsseiten

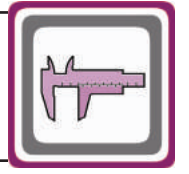

-Mil üçü çektirme deliği DIN 332 sayfa 2 / Tapped center hole to DIN 332, sheet 2 / Zentrierung mit gewinde DIN 332, Blatt 2

KT002.00  
KT003.00

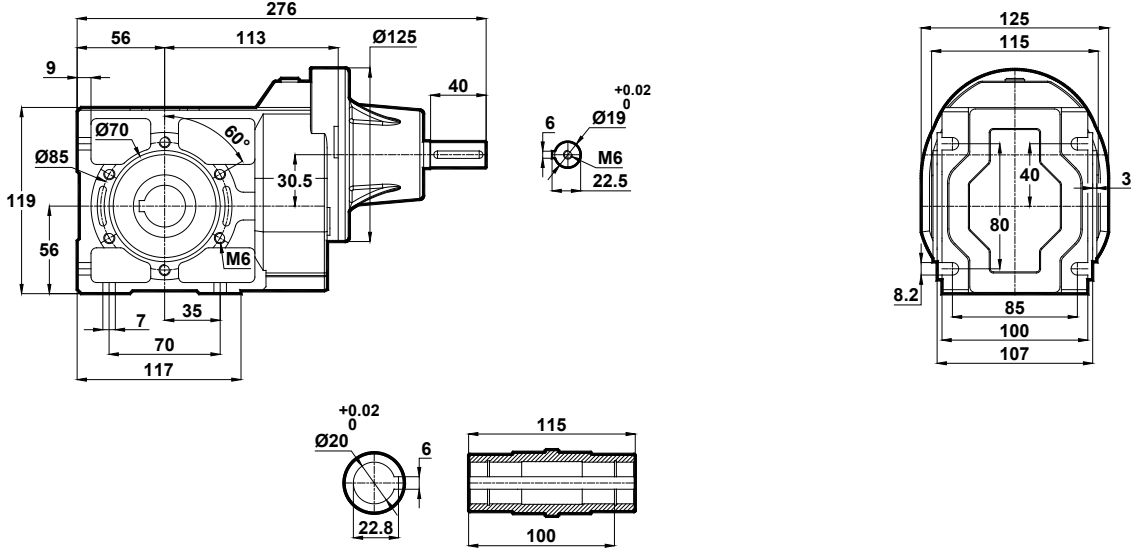

KT002.01  
KT003.01

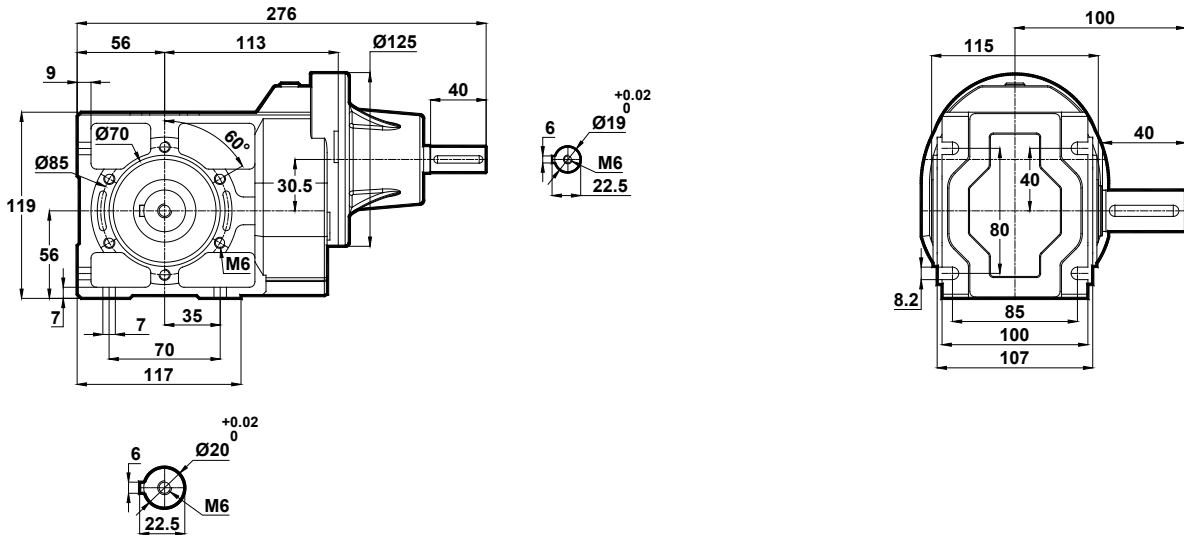

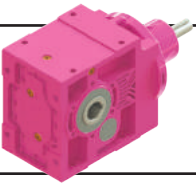

# Ölçü Sayfaları Dimension Pages Abmessungenseiten

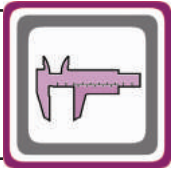

-Mil ucu çekirme deliği DIN 332 sayfa 2 / Tapped center hole to DIN 332, sheet 2 / Zentrierung mit gewinde DIN 332, Blatt 2

KT002.02  
KT003.02

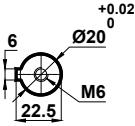
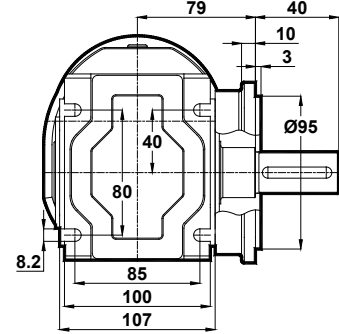
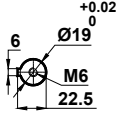
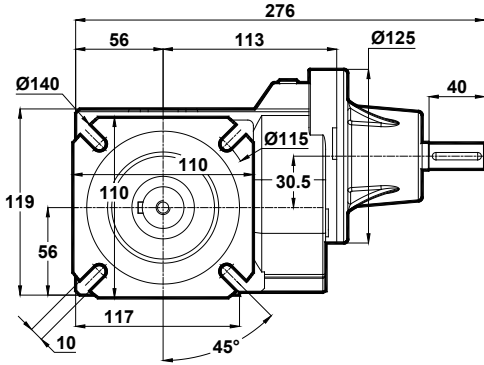

KT002.03  
KT003.03

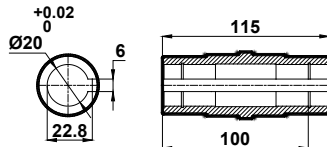
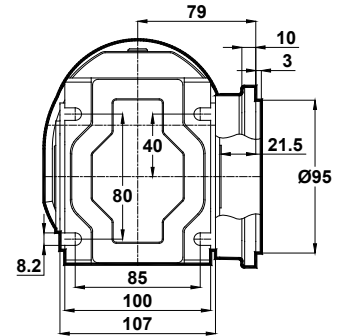
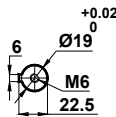
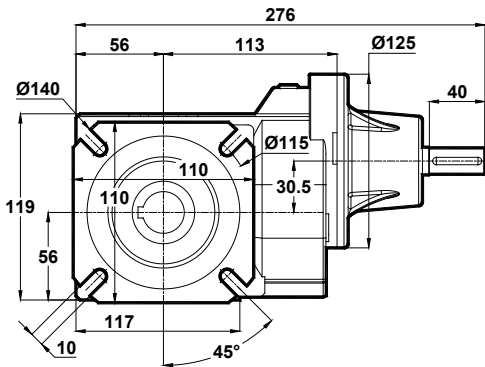

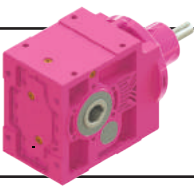

# Ölçü Sayfaları

## Dimension Pages

### Abmessungsseiten

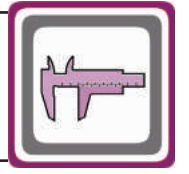

-Mil ucu çekirme deliği DIN 332 sayfa 2 / Tapped center hole to DIN 332, sheet 2 / Zentrierung mit gewinde DIN 332, Blatt 2

KT002.04  
KT003.04

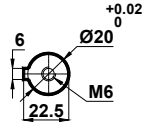
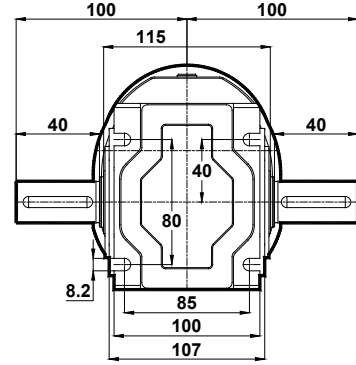
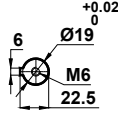
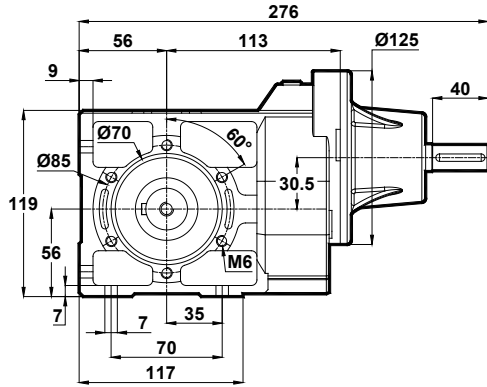

KT002.05  
KT003.05

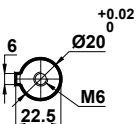
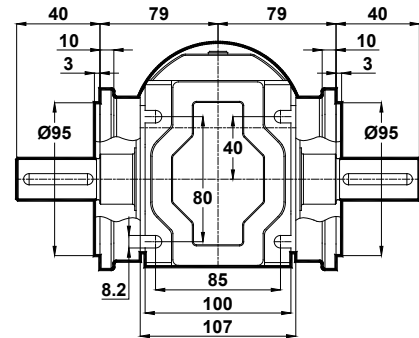
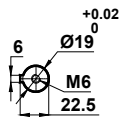
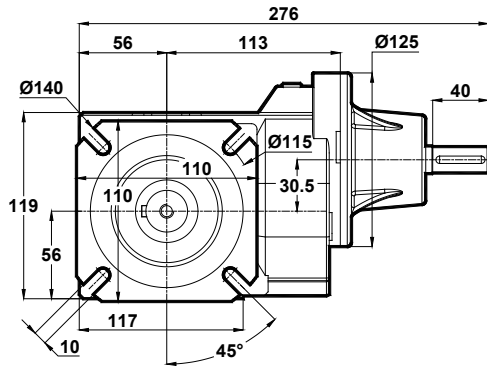

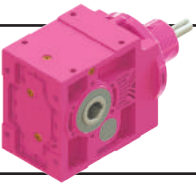

# Ölçü Sayfaları

## Dimension Pages

### Abmessungsseiten

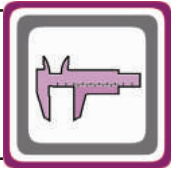

-Mil ucu çekirme deliği DIN 332 sayfa 2 / Tapped center hole to DIN 332, sheet 2 / Zentrierung mit gewinde DIN 332, Blatt 2

KT002.08  
KT003.08

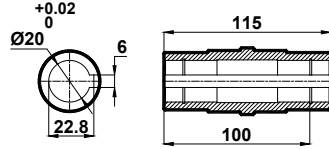
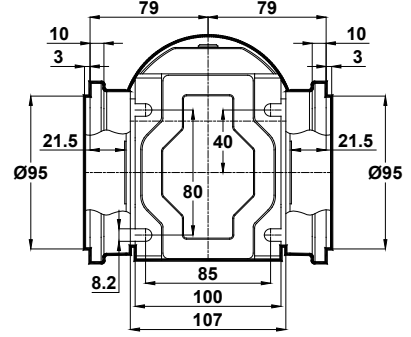
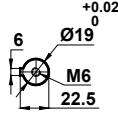
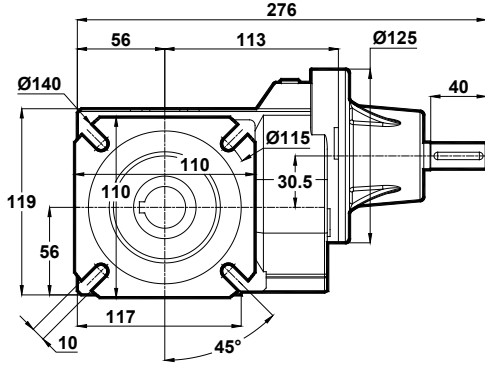

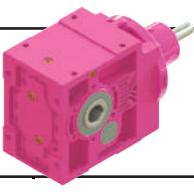

# Ölçü Sayfaları

## Dimension Pages

### Abmessungsseiten

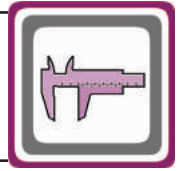

-Mil ucu çekirme deliği DIN 332 sayfa 2 / Tapped center hole to DIN 332, sheet 2 / Zentrierung mit gewinde DIN 332, Blatt 2

KT102.00  
KT103.00

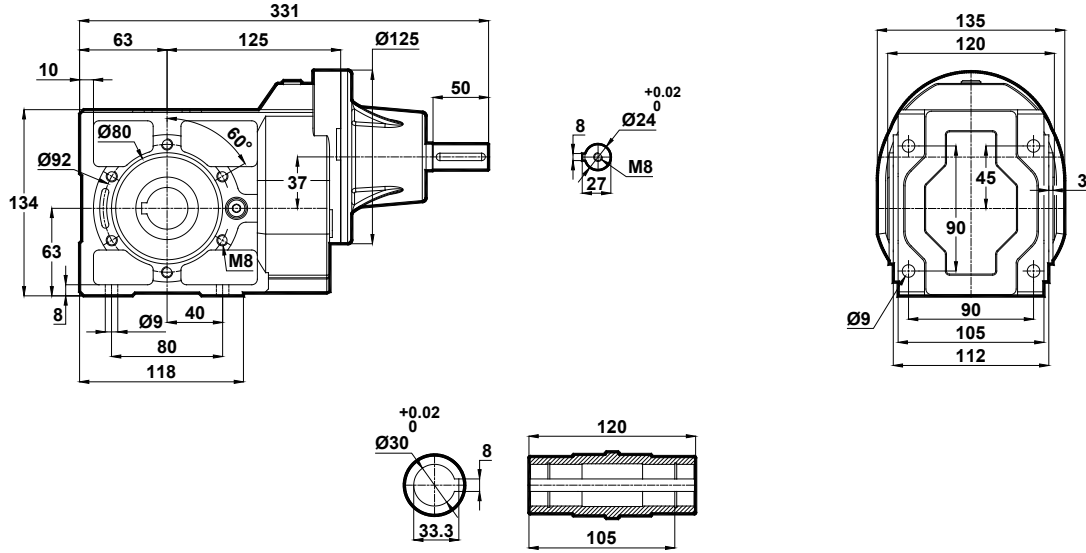

KT102.01  
KT103.01

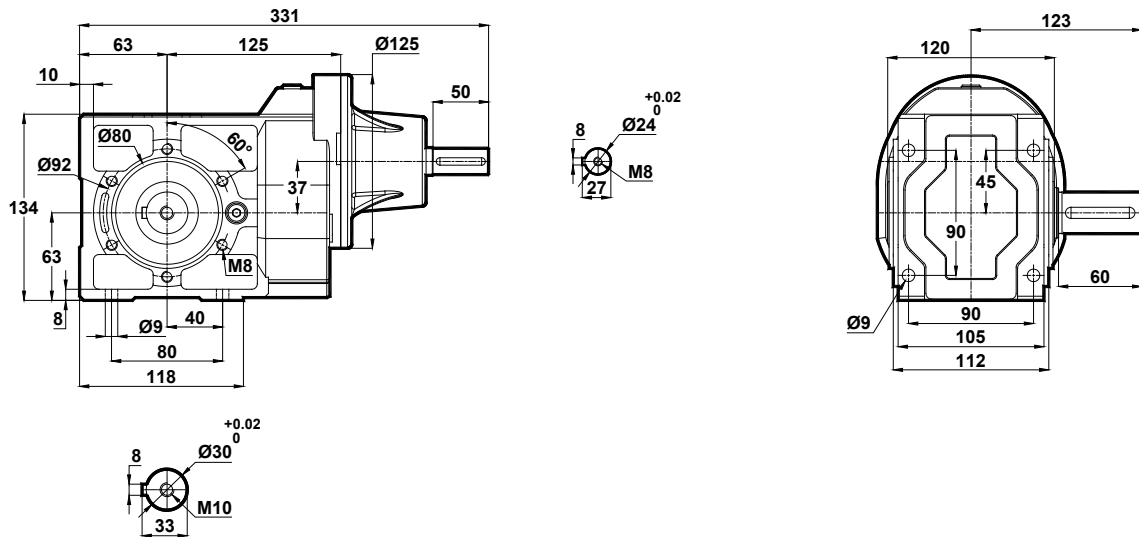

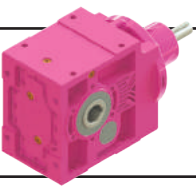

# Ölçü Sayfaları

## Dimension Pages

### Abmessungsseiten

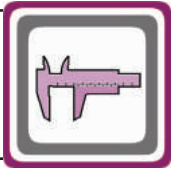

-Mil ucu çekirme deliği DIN 332 sayfa 2 / Tapped center hole to DIN 332, sheet 2 / Zentrierung mit gewinde DIN 332, Blatt 2

KT102.02  
KT103.02

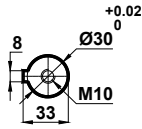
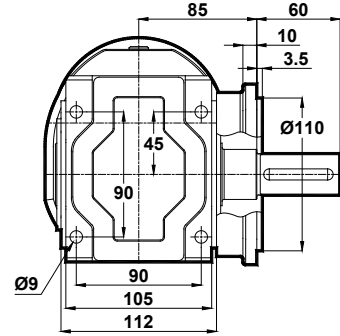
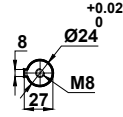
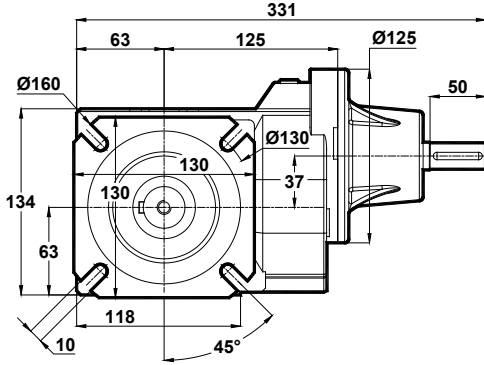

KT102.03  
KT103.03

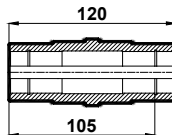
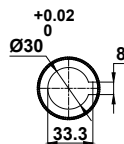
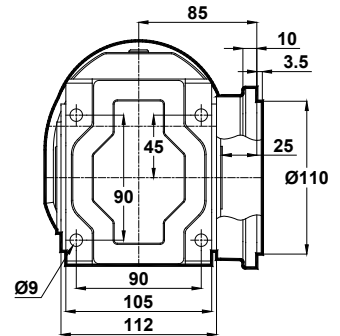
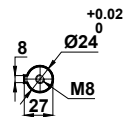
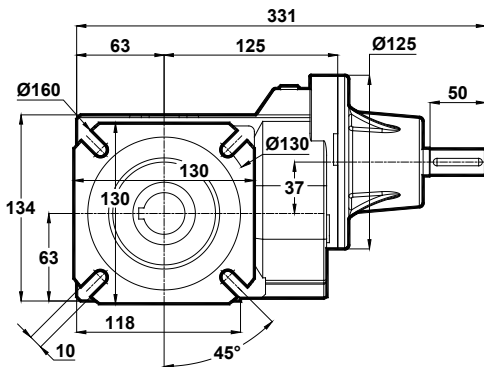



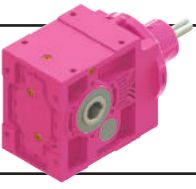

# Ölçü Sayfaları Dimension Pages Abmessungsseiten

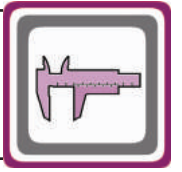

-Mil ucu çekirme deliği DIN 332 sayfa 2 / Tapped center hole to DIN 332, sheet 2 / Zentrierung mit gewinde DIN 332, Blatt 2

KT102.08  
KT103.08

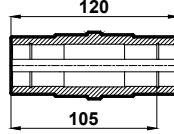
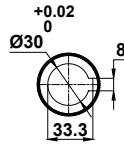
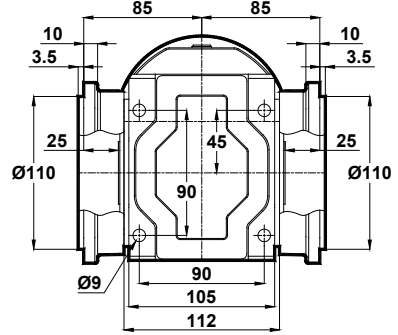
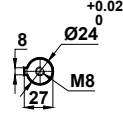
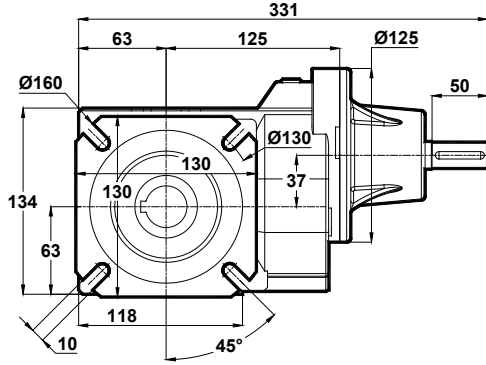

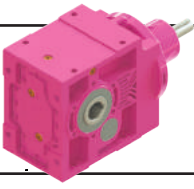

# Ölçü Sayfaları

## Dimension Pages

### Abmessungenseiten

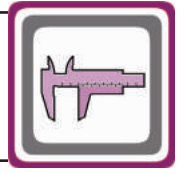

-Mil ucu çekirme deliği DIN 332 sayfa 2 / Tapped center hole to DIN 332, sheet 2 / Zentrierung mit gewinde DIN 332, Blatt 2

KT202.00  
KT203.00

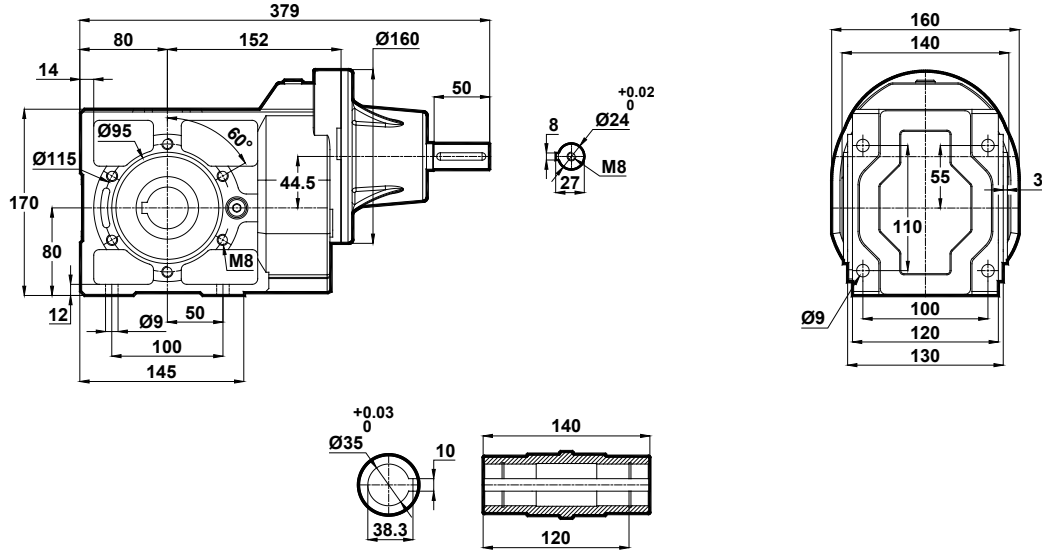

KT202.01  
KT203.01

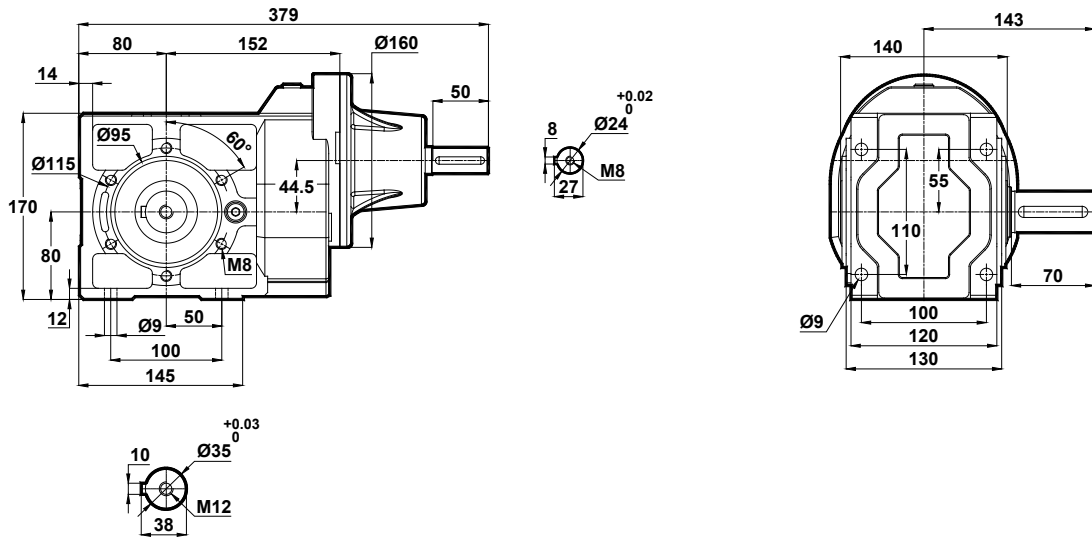





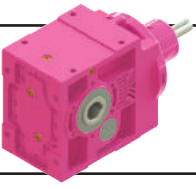

# Ölçü Sayfaları Dimension Pages Abmessungenseiten

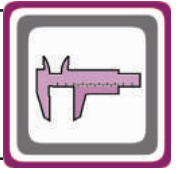

-Mil ucu çekirme deliği DIN 332 sayfa 2 / Tapped center hole to DIN 332, sheet 2 / Zentrierung mit gewinde DIN 332, Blatt 2

KT202.08  
KT203.08

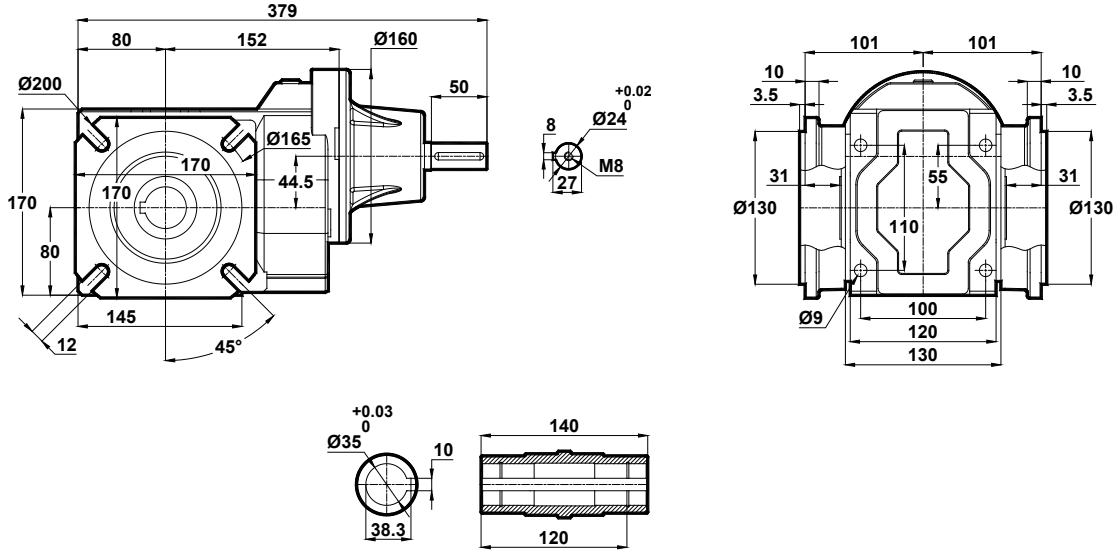

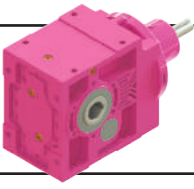

# Ölçü Sayfaları Dimension Pages Abmessungsseiten

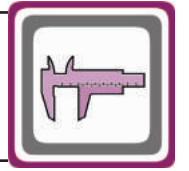

-Mil ucu çektirme deliği DIN 332 sayfa 2 / Tapped center hole to DIN 332, sheet 2 / Zentrierung mit gewinde DIN 332, Blatt 2

## KT273.00

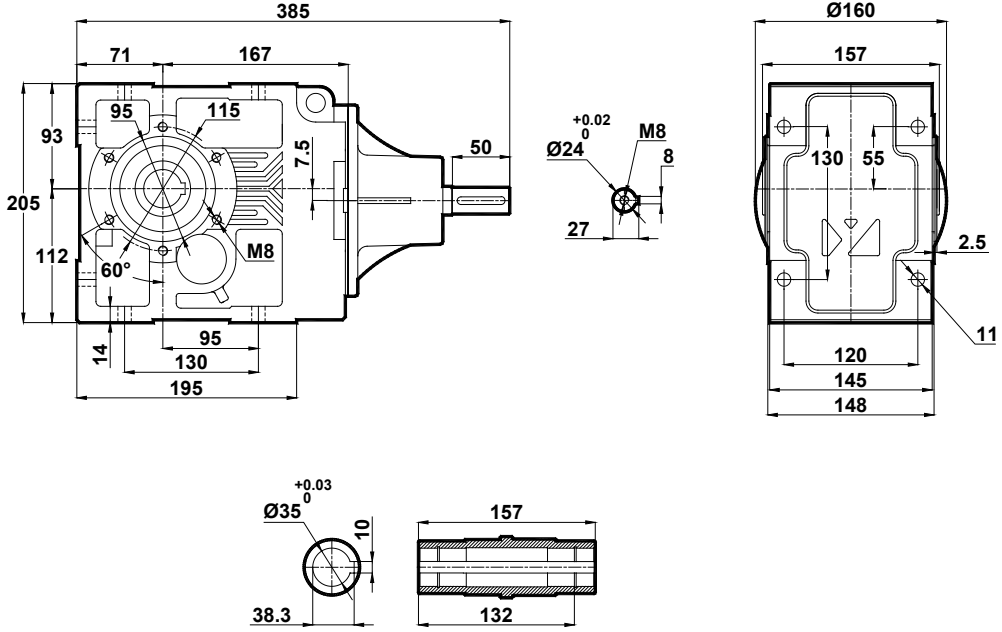

## KT273.01

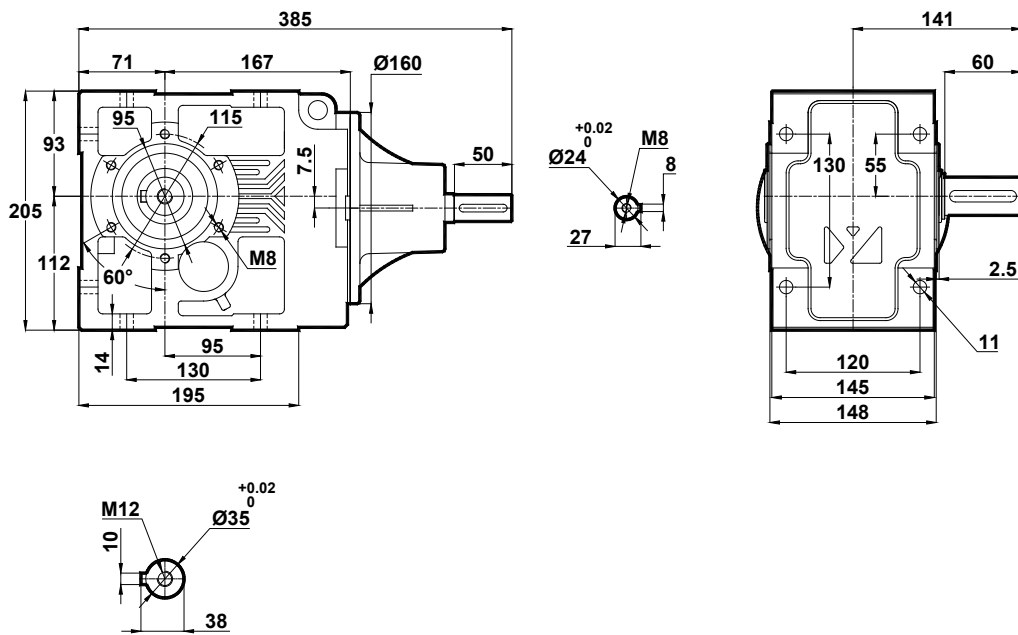



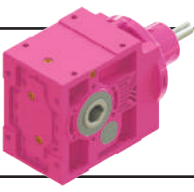

# Ölçü Sayfaları

## Dimension Pages

### Abmessungsseiten

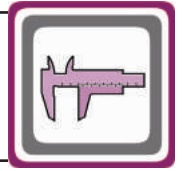

-Mil ucu çekirme deliği DIN 332 sayfa 2 / Tapped center hole to DIN 332, sheet 2 / Zentrierung mit gewinde DIN 332, Blatt 2

#### KT273.04

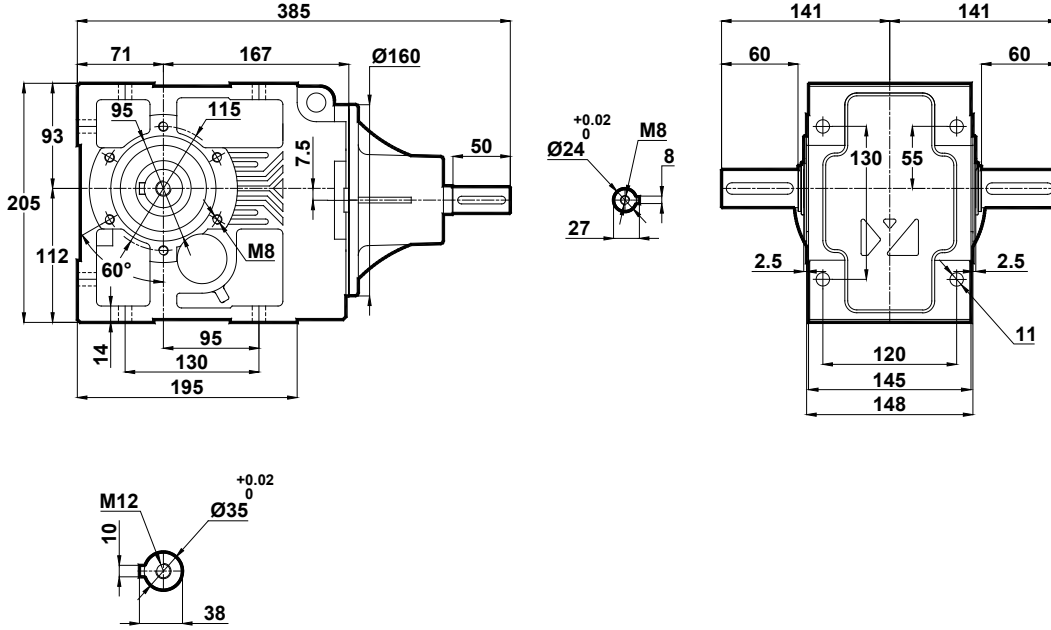

#### KT273.05

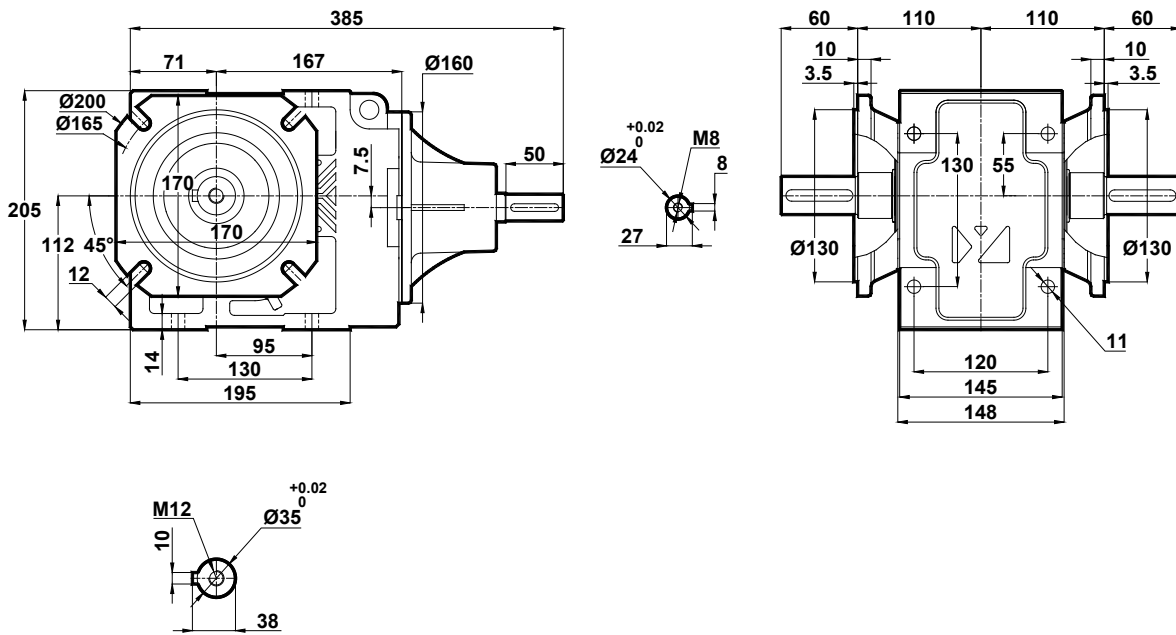

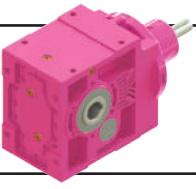

# Ölçü Sayfaları

## Dimension Pages

### Abmessungsseiten

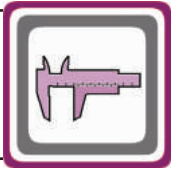

-Mil ucu çekirme deliği DIN 332 sayfa 2 / Tapped center hole to DIN 332, sheet 2 / Zentrierung mit gewinde DIN 332, Blatt 2

KT273.08

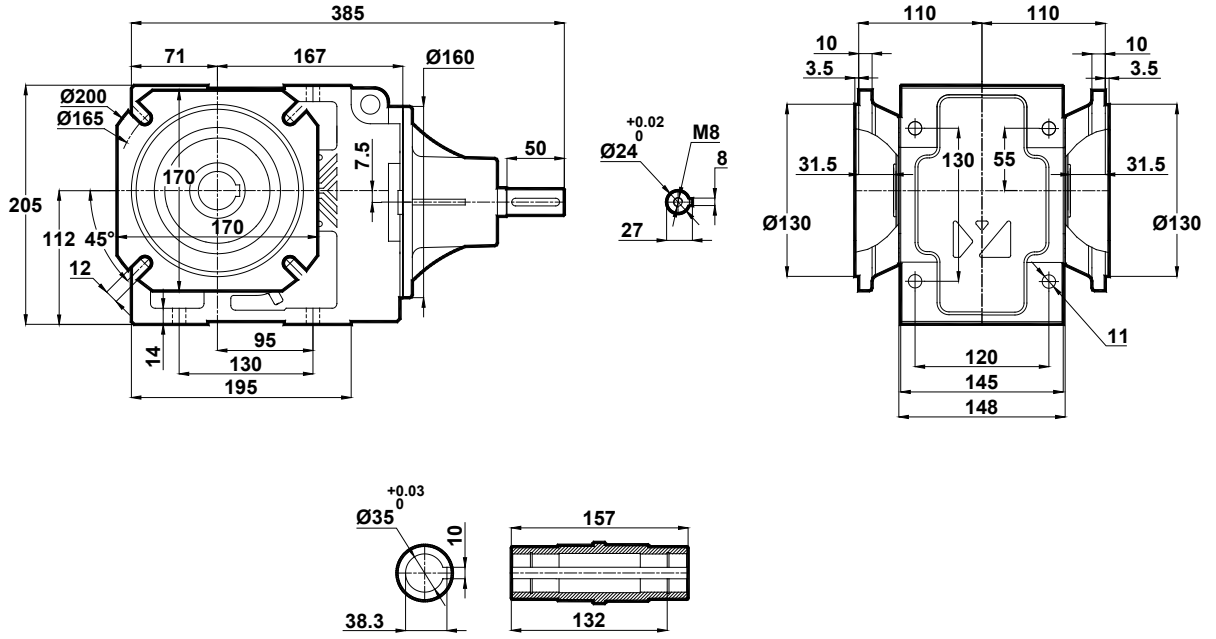

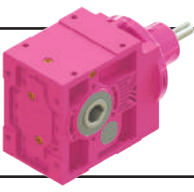

# Ölçü Sayfaları Dimension Pages Abmessungenseiten

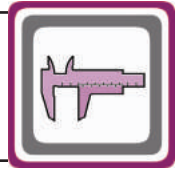

-Mil ucu çekirme deliği DIN 332 sayfa 2 / Tapped center hole to DIN 332, sheet 2 / Zentrierung mit gewinde DIN 332, Blatt 2

KT275.00  
KT276.00

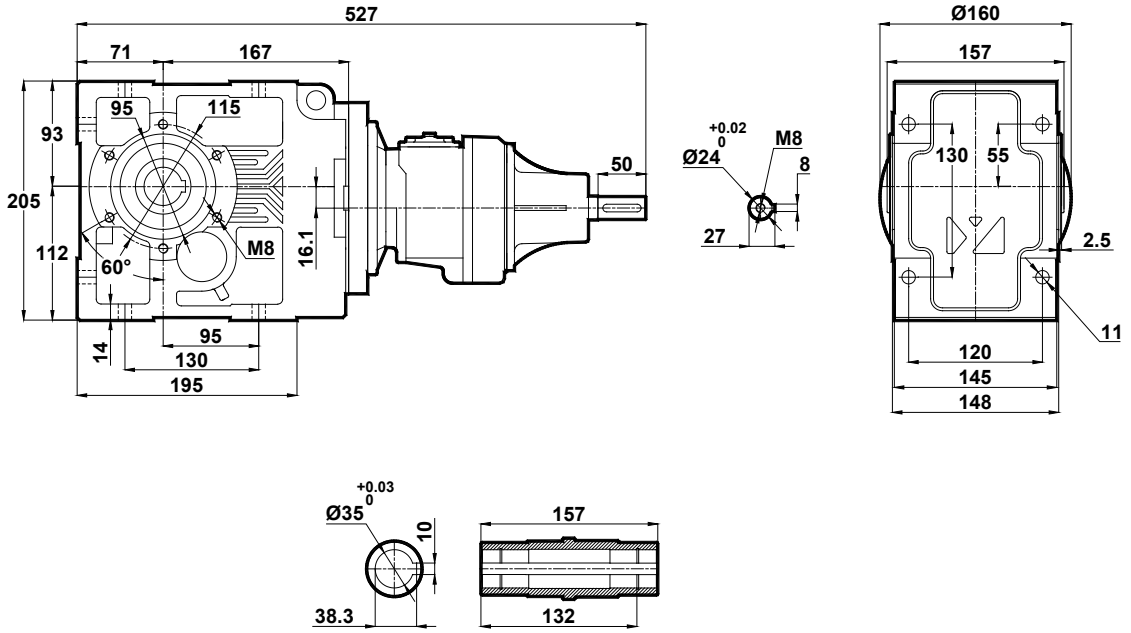

KT275.01  
KT276.01

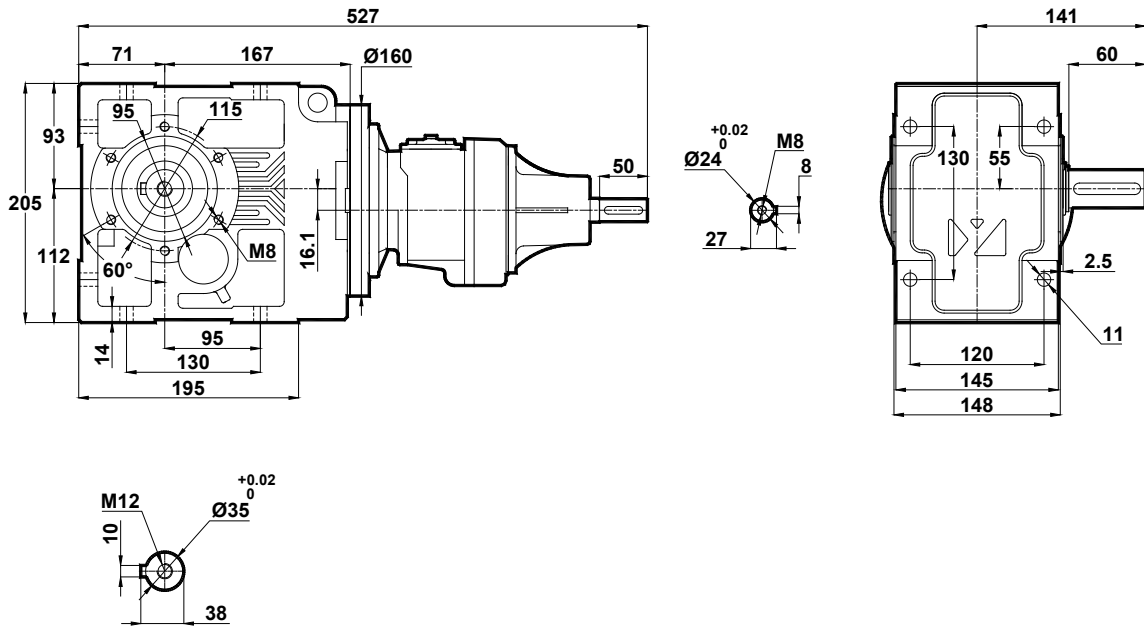

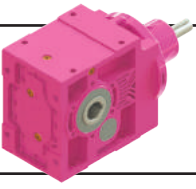

# Ölçü Sayfaları

## Dimension Pages

### Abmessungsseiten

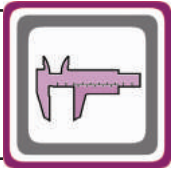

-Mil ucu çektirme deliği DIN 332 sayfa 2 / Tapped center hole to DIN 332, sheet 2 / Zentrierung mit gewinde DIN 332, Blatt 2

KT275.02  
KT276.02

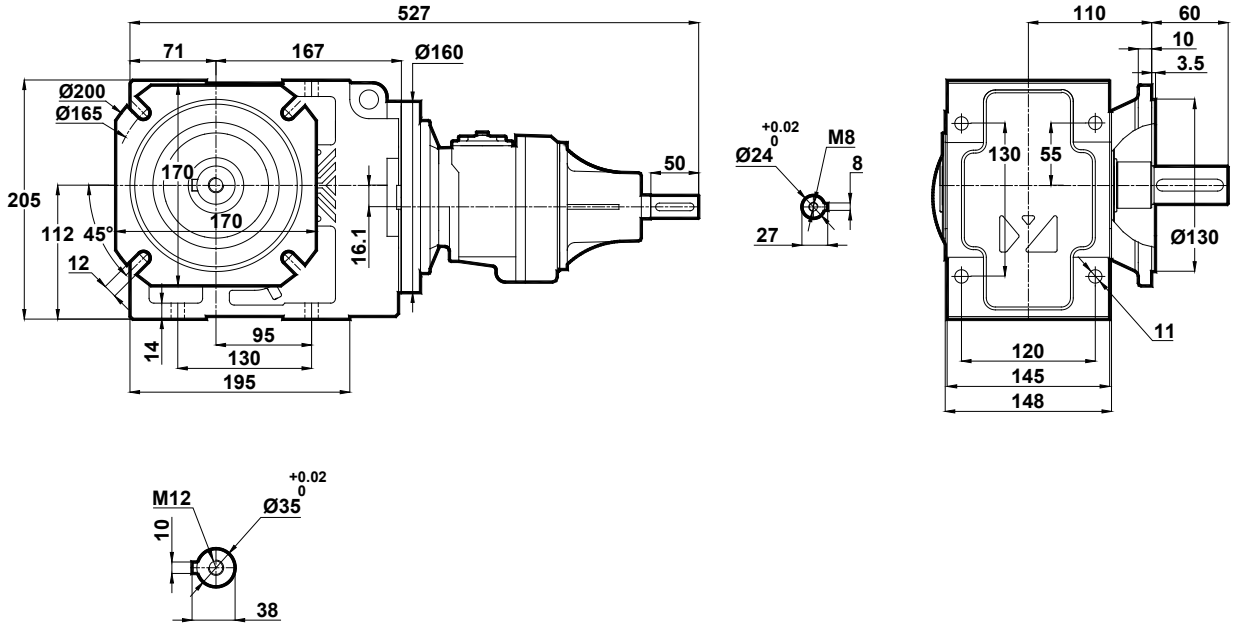

KT275.03  
KT276.03

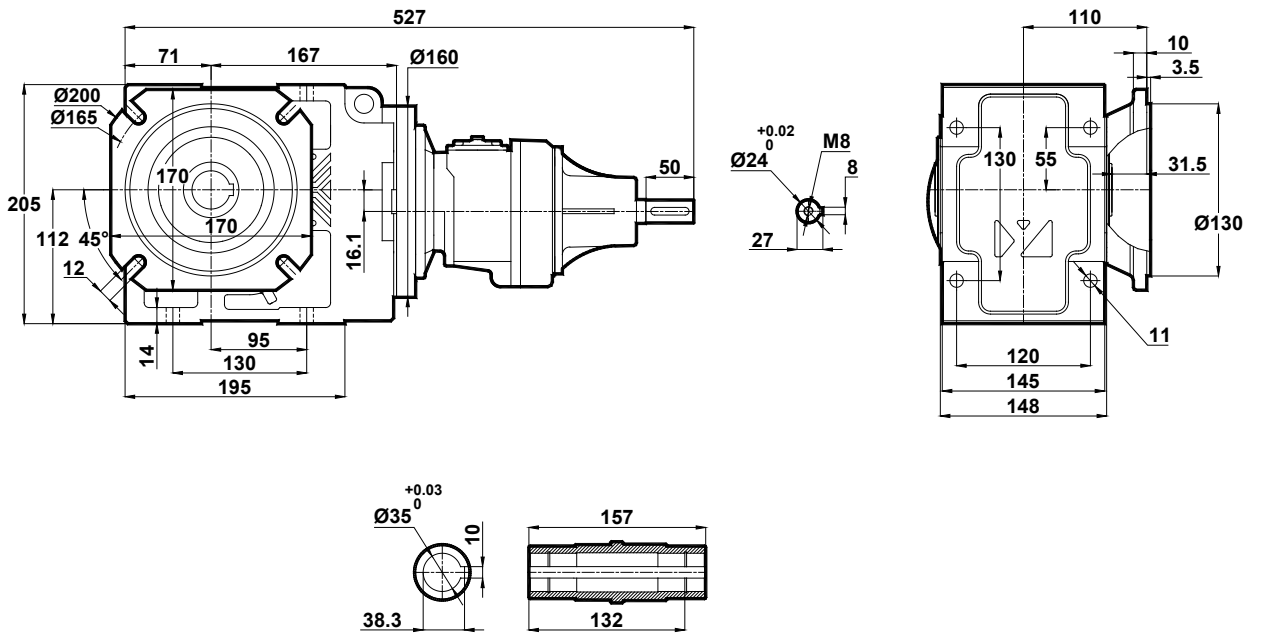

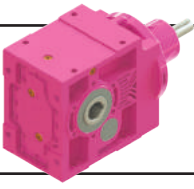

# Ölçü Sayfaları

## Dimension Pages

### Abmessungsseiten

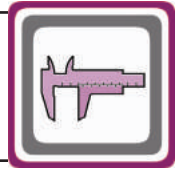

-Mil ucu çekirme deliği DIN 332 sayfa 2 / Tapped center hole to DIN 332, sheet 2 / Zentrierung mit gewinde DIN 332, Blatt 2

KT275.04  
KT276.04

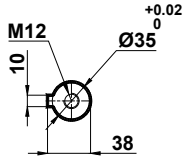
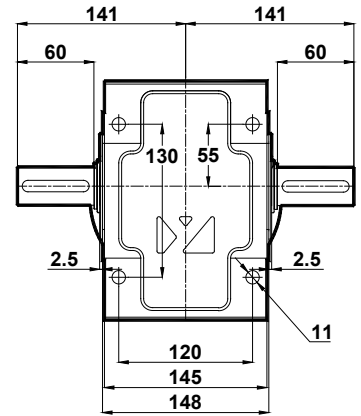
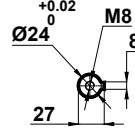
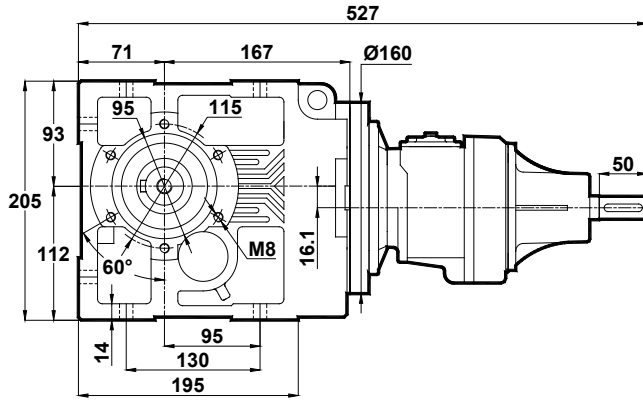

KT275.05  
KT276.05

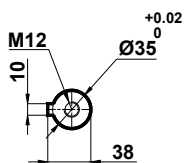
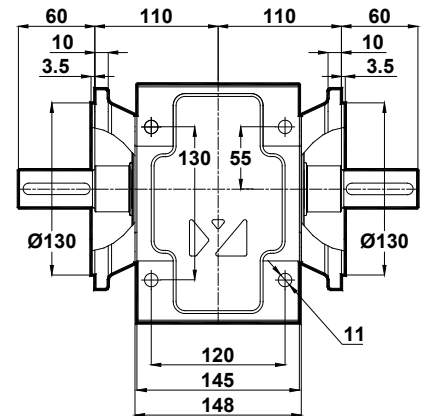
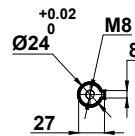
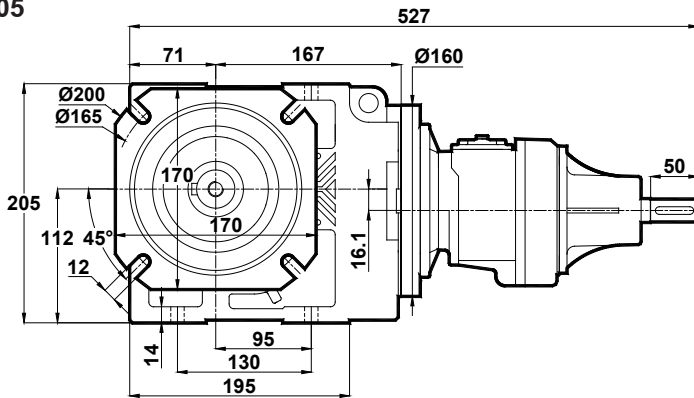

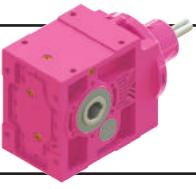

# Ölçü Sayfaları Dimension Pages Abmessungenseiten

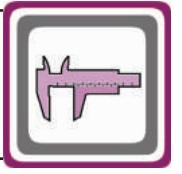

-Mil ucu çekirme deliği DIN 332 sayfa 2 / Tapped center hole to DIN 332, sheet 2 / Zentrierung mit gewinde DIN 332, Blatt 2

KT275.08  
KT276.08

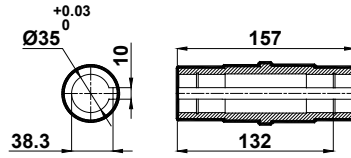
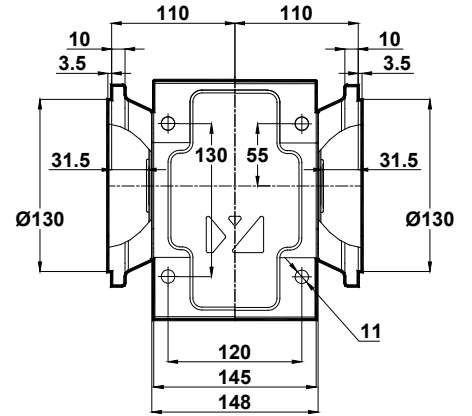
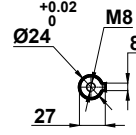
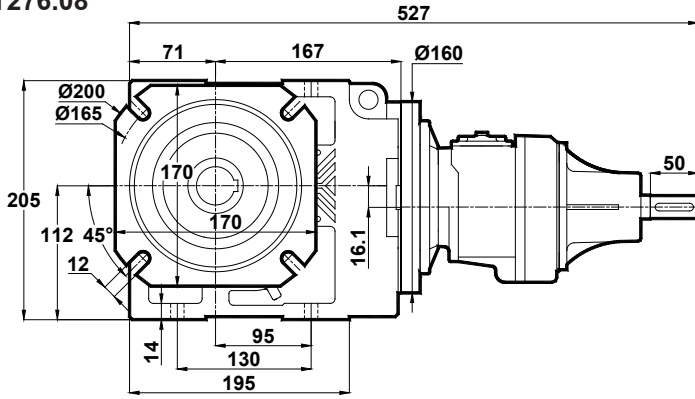

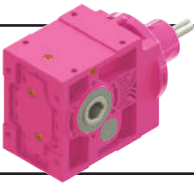

# Ölçü Sayfaları

## Dimension Pages

### Abmessungenseiten

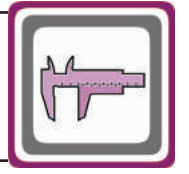

-Mil ucu çekirme deliği DIN 332 sayfa 2 / Tapped center hole to DIN 332, sheet 2 / Zentrierung mit gewinde DIN 332, Blatt 2

KT373.00

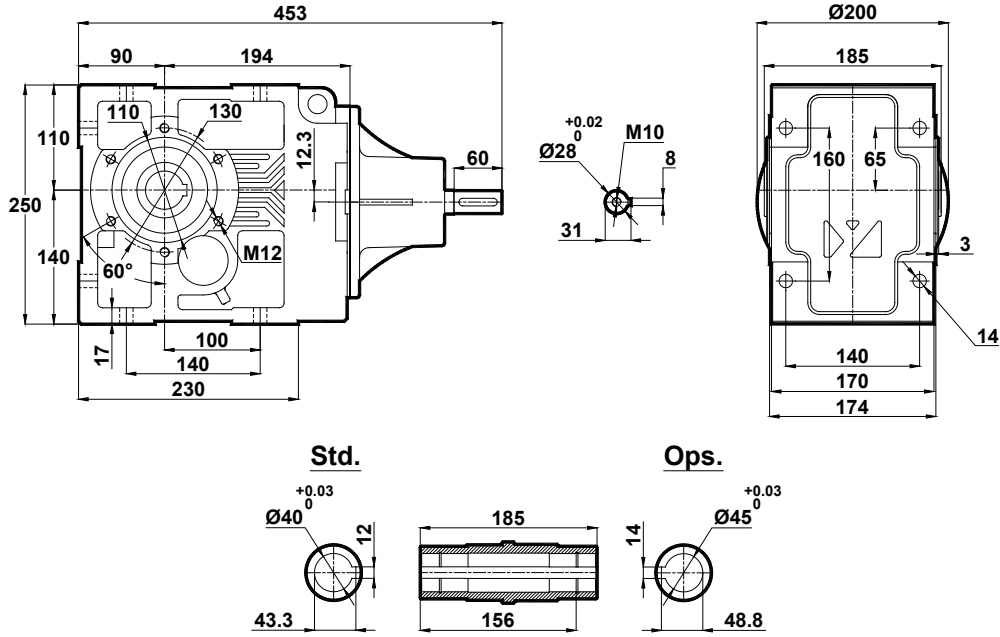

KT373.01

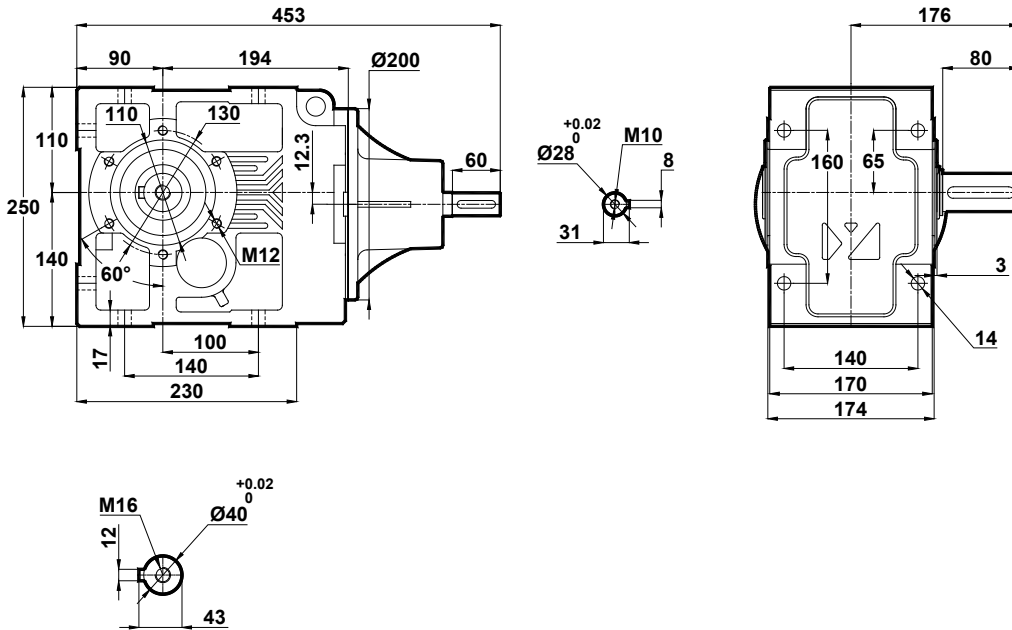

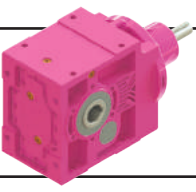

# Ölçü Sayfaları

## Dimension Pages

### Abmessungsseiten

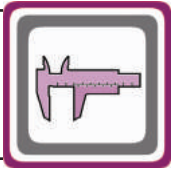

-Mil ucu çekirme deliği DIN 332 sayfa 2 / Tapped center hole to DIN 332, sheet 2 / Zentrierung mit gewinde DIN 332, Blatt 2

KT373.02

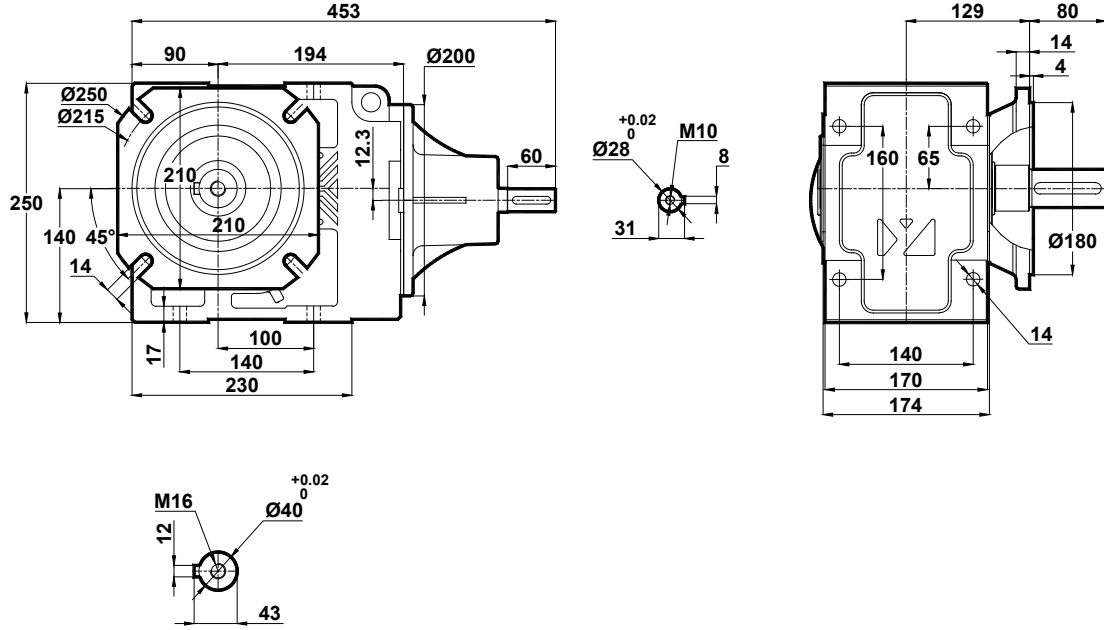

KT373.03

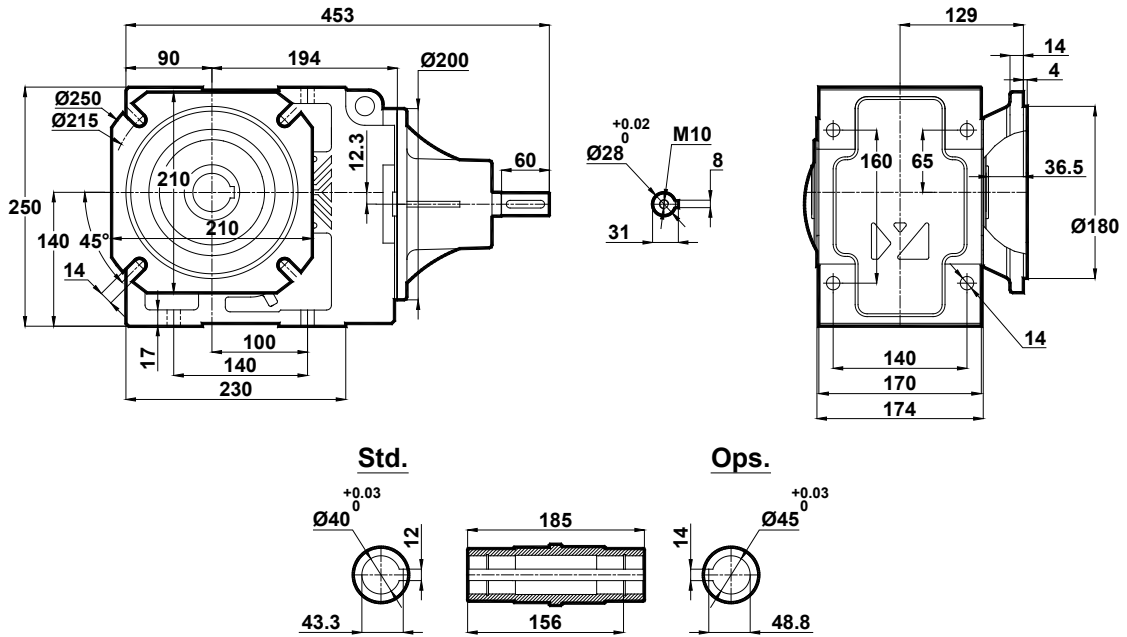

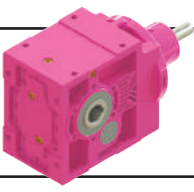

# Ölçü Sayfaları

## Dimension Pages

### Abmessungsseiten

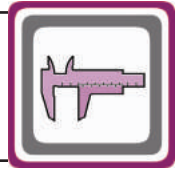

-Mil ucu çekirme deliği DIN 332 sayfa 2 / Tapped center hole to DIN 332, sheet 2 / Zentrierung mit gewinde DIN 332, Blatt 2

#### KT373.04

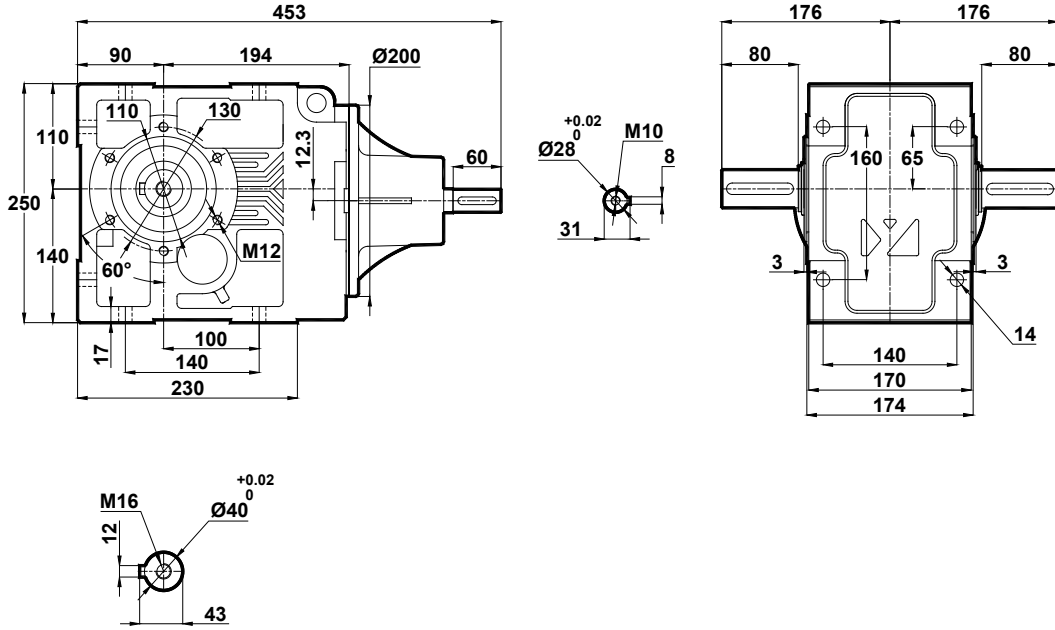

#### KT373.05

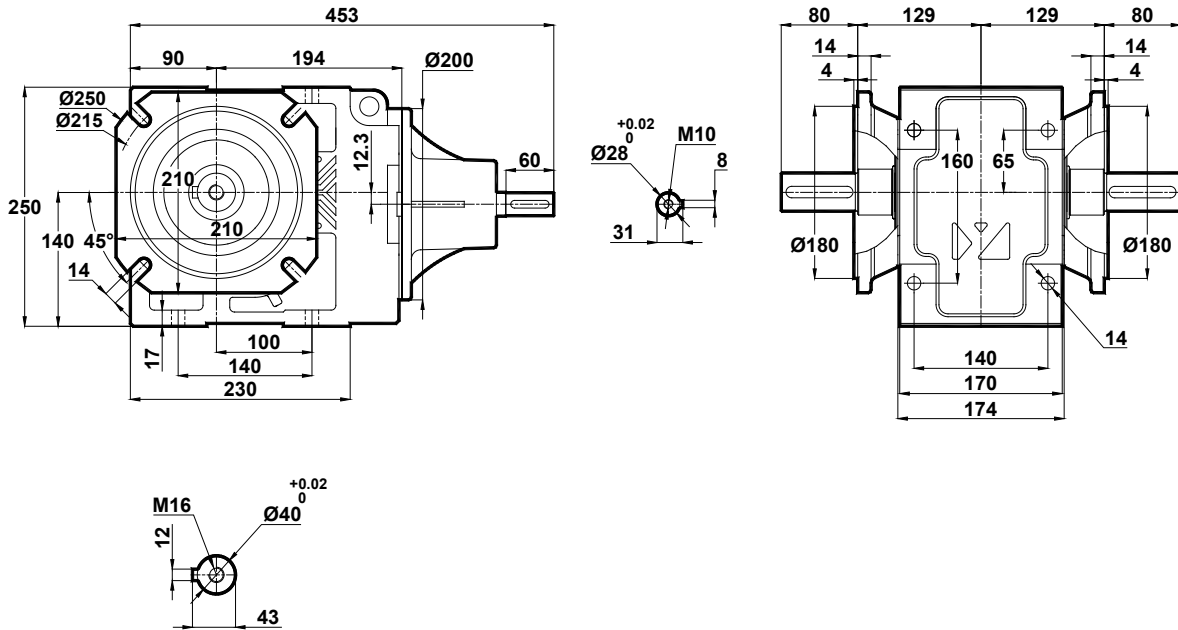

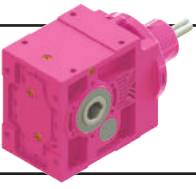

# Ölçü Sayfaları Dimension Pages Abmessungenseiten

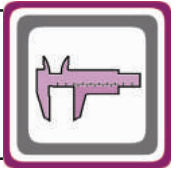

-Mil ucu çekirme deliği DIN 332 sayfa 2 / Tapped center hole to DIN 332, sheet 2 / Zentrierung mit gewinde DIN 332, Blatt 2

KT373.08

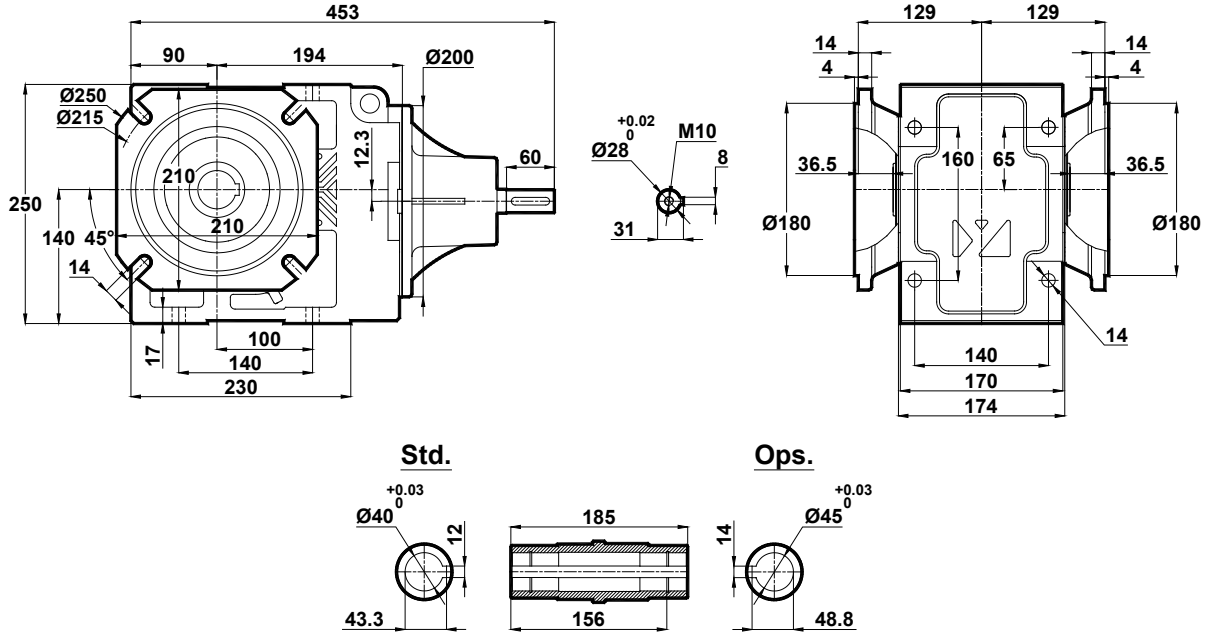

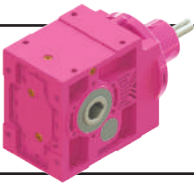

# Ölçü Sayfaları

## Dimension Pages

### Abmessungsseiten

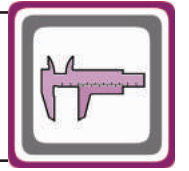

-Mil ucu çekirme deliği DIN 332 sayfa 2 / Tapped center hole to DIN 332, sheet 2 / Zentrierung mit gewinde DIN 332, Blatt 2

KT374.00

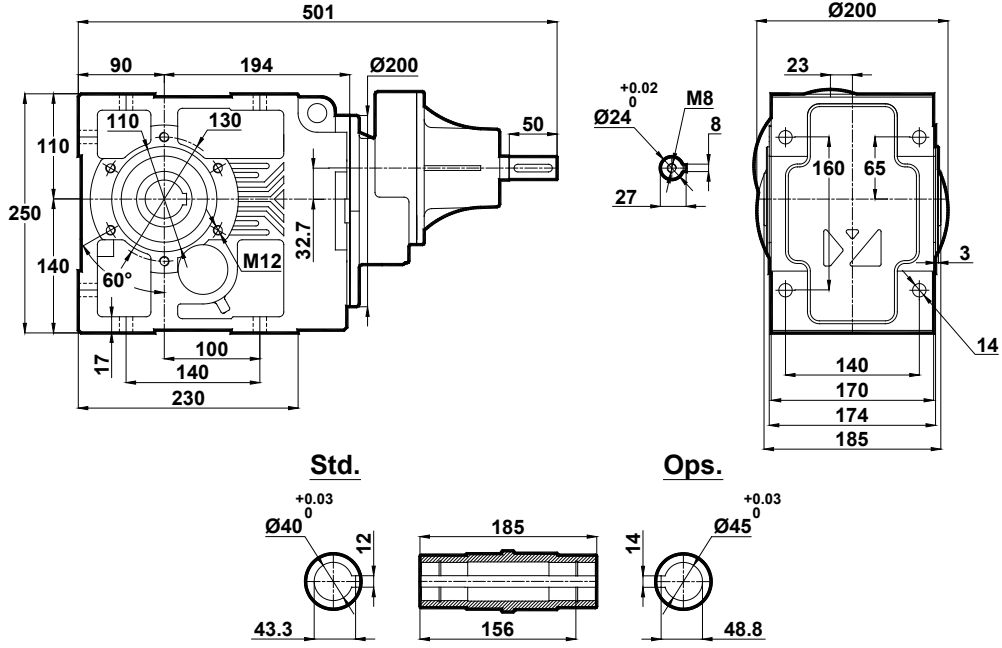

KT374.01

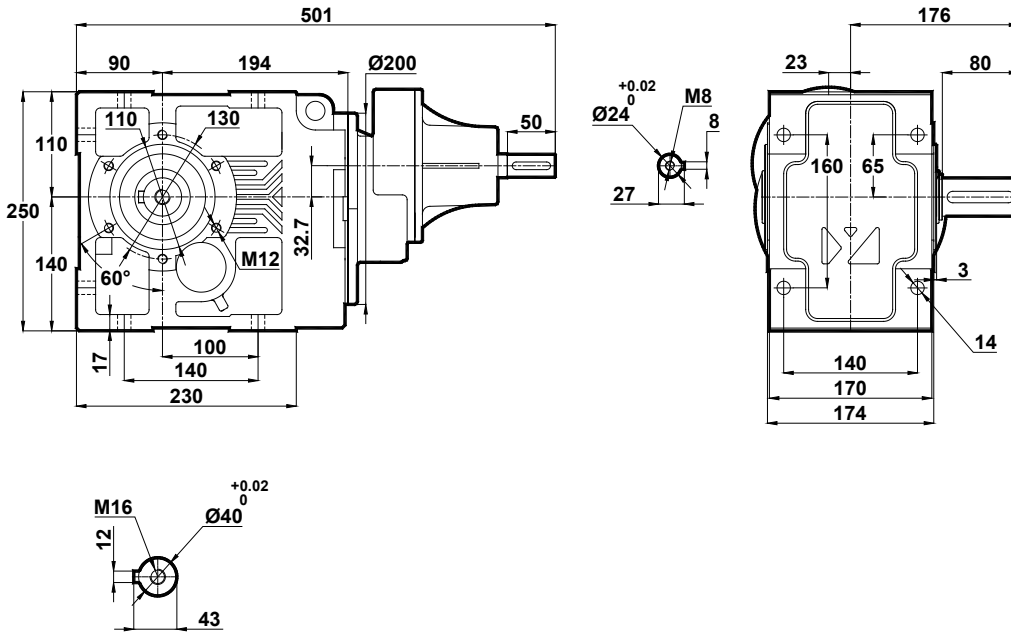

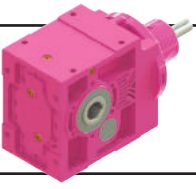

# Ölçü Sayfaları

## Dimension Pages

### Abmessungsseiten

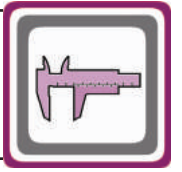

-Mil ucu çektirme deliği DIN 332 sayfa 2 / Tapped center hole to DIN 332, sheet 2 / Zentrierung mit gewinde DIN 332, Blatt 2

KT374.02

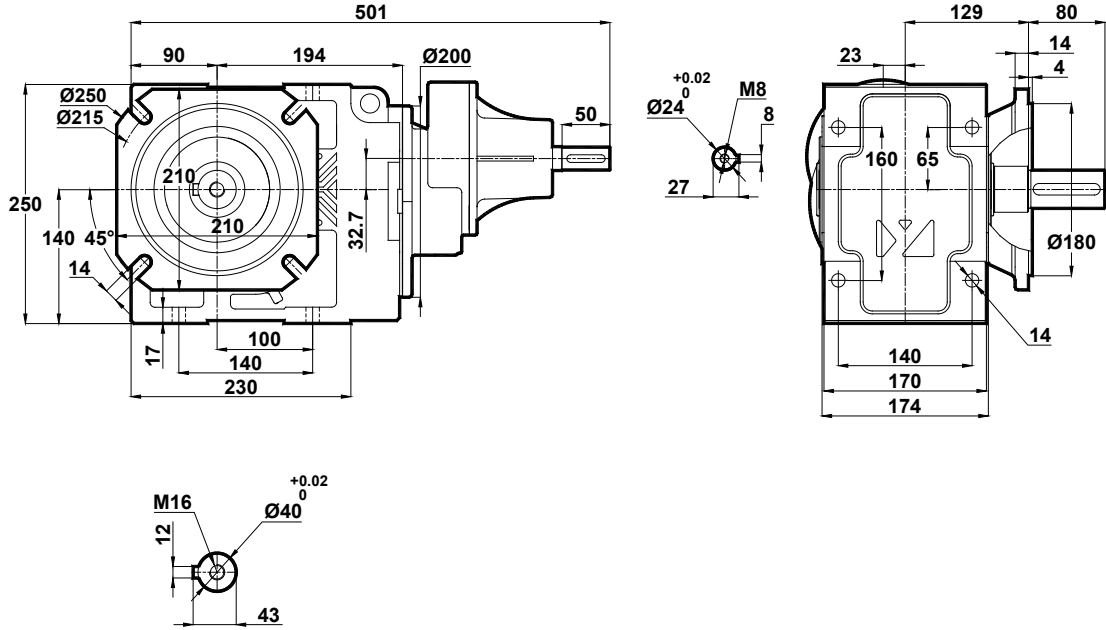

KT374.03

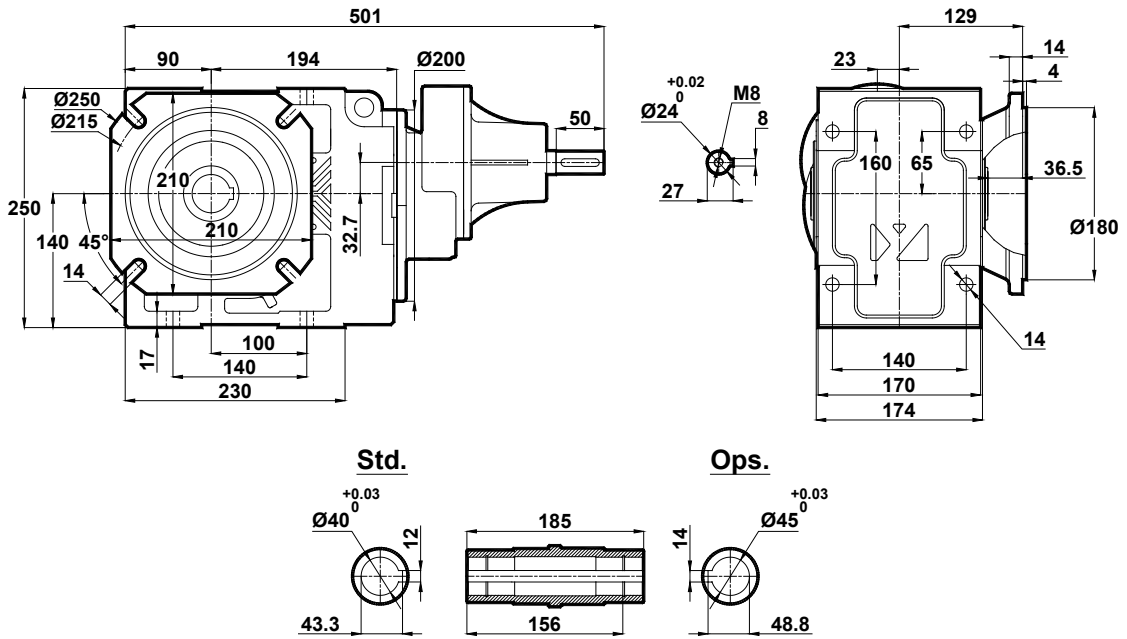

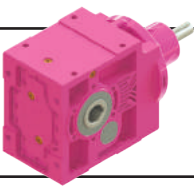

# Ölçü Sayfaları

## Dimension Pages

### Abmessungsseiten

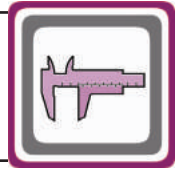

-Mil ucu çekirme deliği DIN 332 sayfa 2 / Tapped center hole to DIN 332, sheet 2 / Zentrierung mit gewinde DIN 332, Blatt 2

#### KT374.04

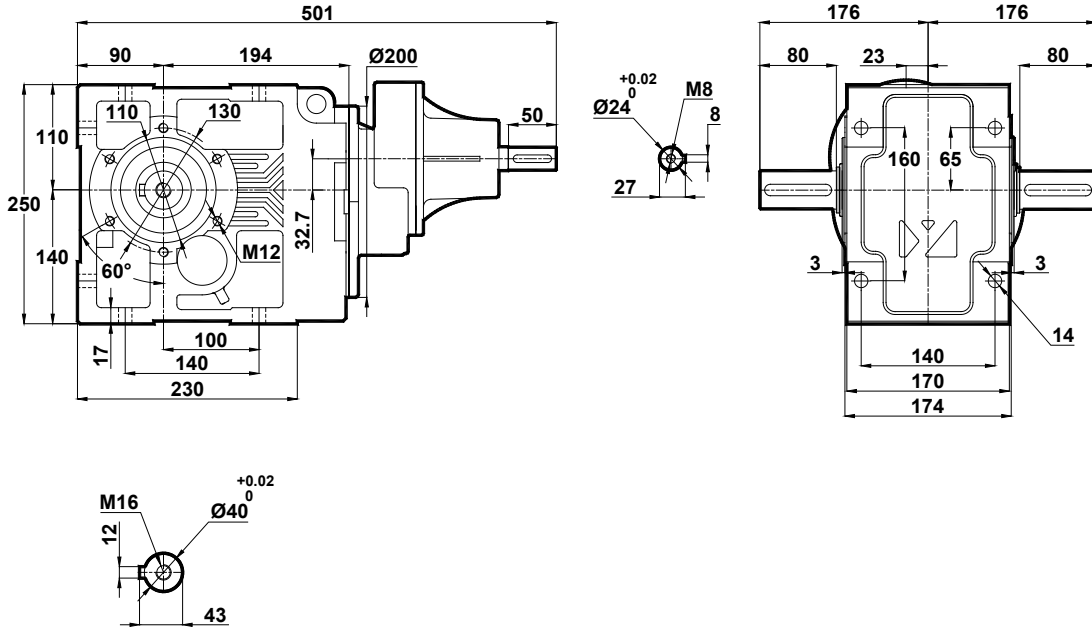

#### KT374.05

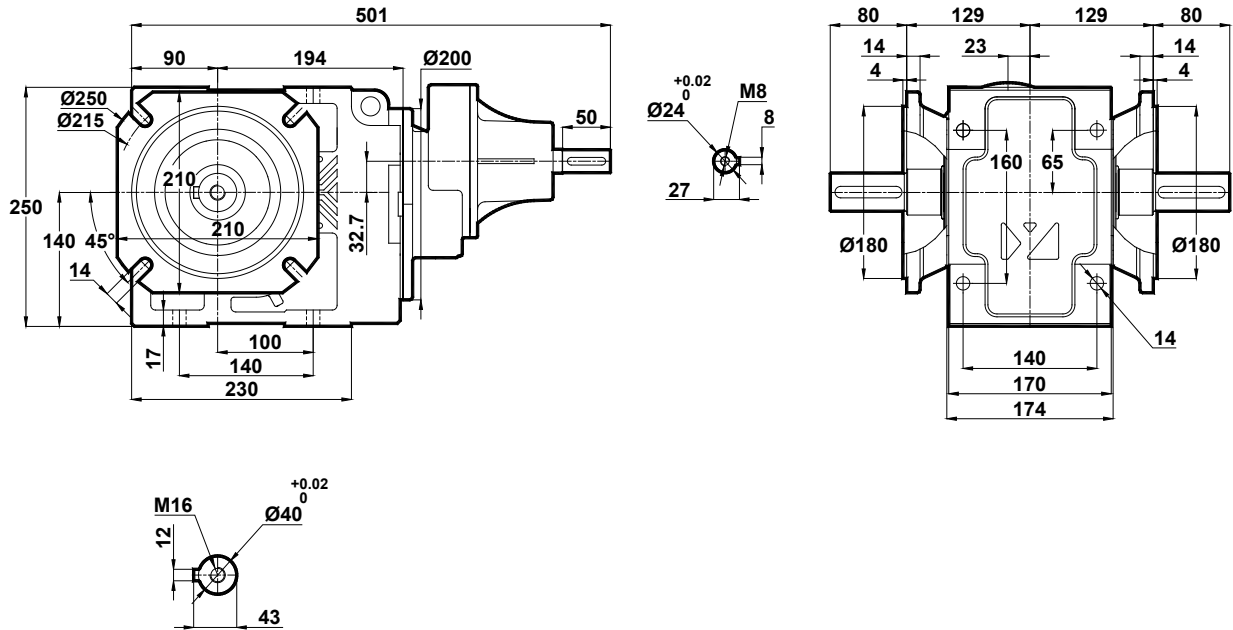

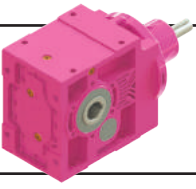

# Ölçü Sayfaları

## Dimension Pages

### Abmessungsseiten

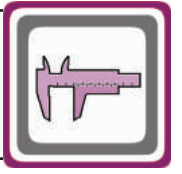

-Mil ucu çekirme deliği DIN 332 sayfa 2 / Tapped center hole to DIN 332, sheet 2 / Zentrierung mit gewinde DIN 332, Blatt 2

KT374.08

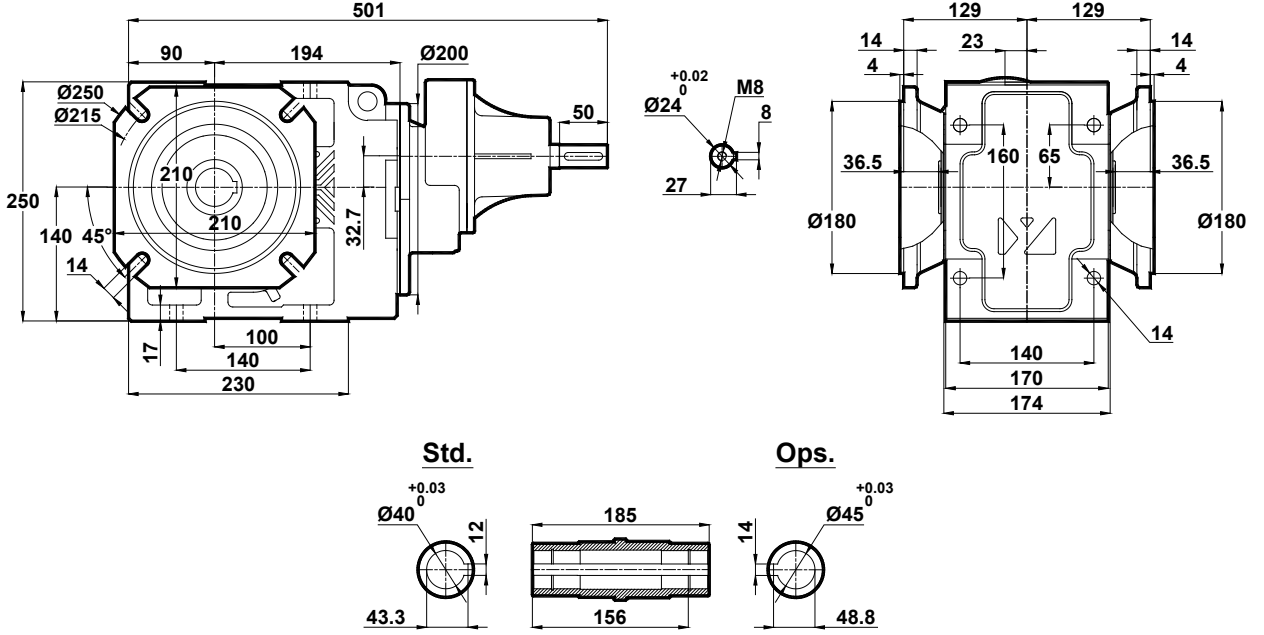

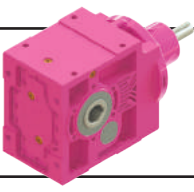

# Ölçü Sayfaları

## Dimension Pages

### Abmessungenseiten

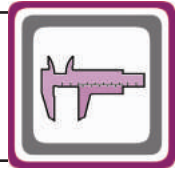

-Mil ucu çekirme deliği DIN 332 sayfa 2 / Tapped center hole to DIN 332, sheet 2 / Zentrierung mit gewinde DIN 332, Blatt 2

KT375.00  
KT376.00

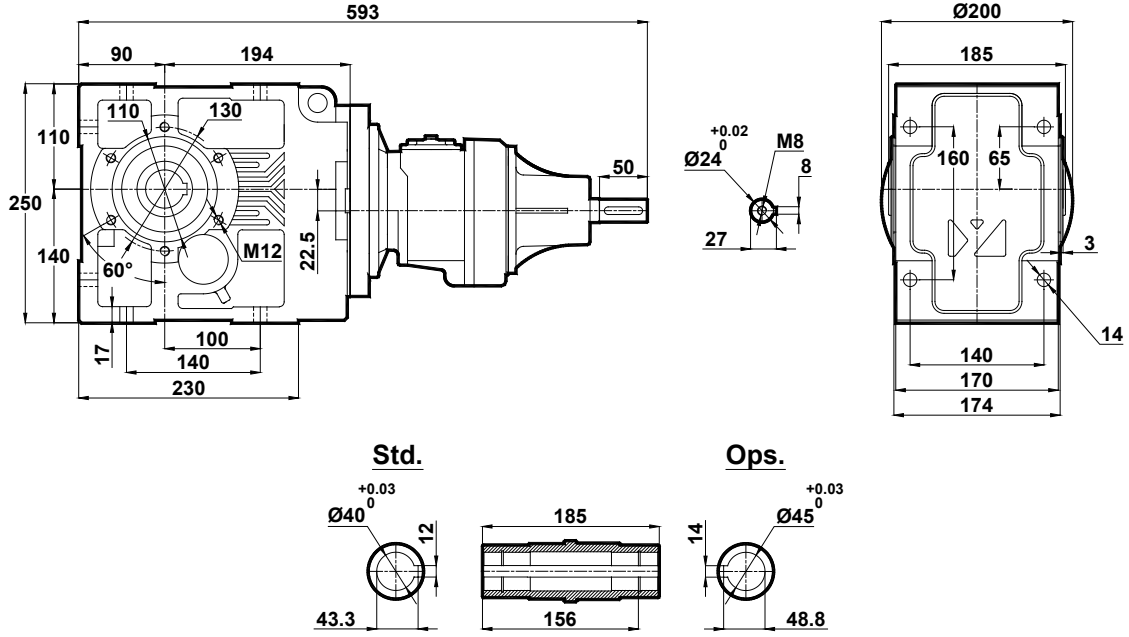

KT375.01  
KT376.01

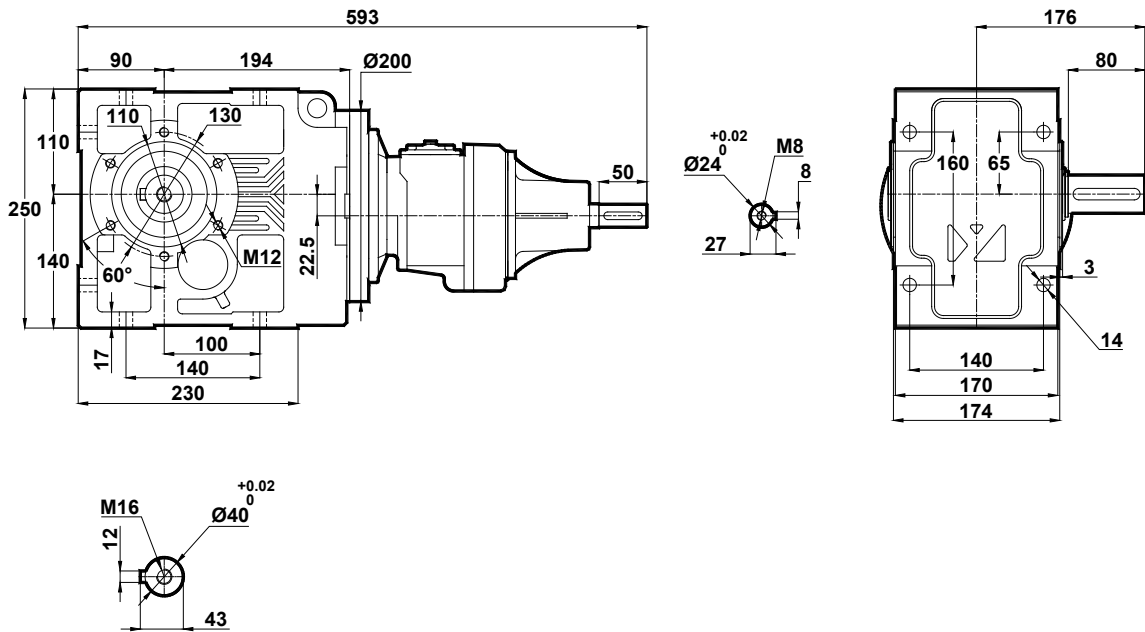

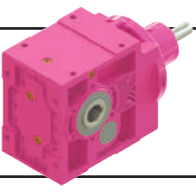

# Ölçü Sayfaları

## Dimension Pages

### Abmessungsseiten

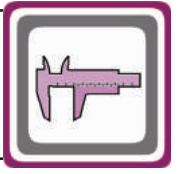

-Mil ucu çekirme deliği DIN 332 sayfa 2 / Tapped center hole to DIN 332, sheet 2 / Zentrierung mit gewinde DIN 332, Blatt 2

KT375.02  
KT376.02

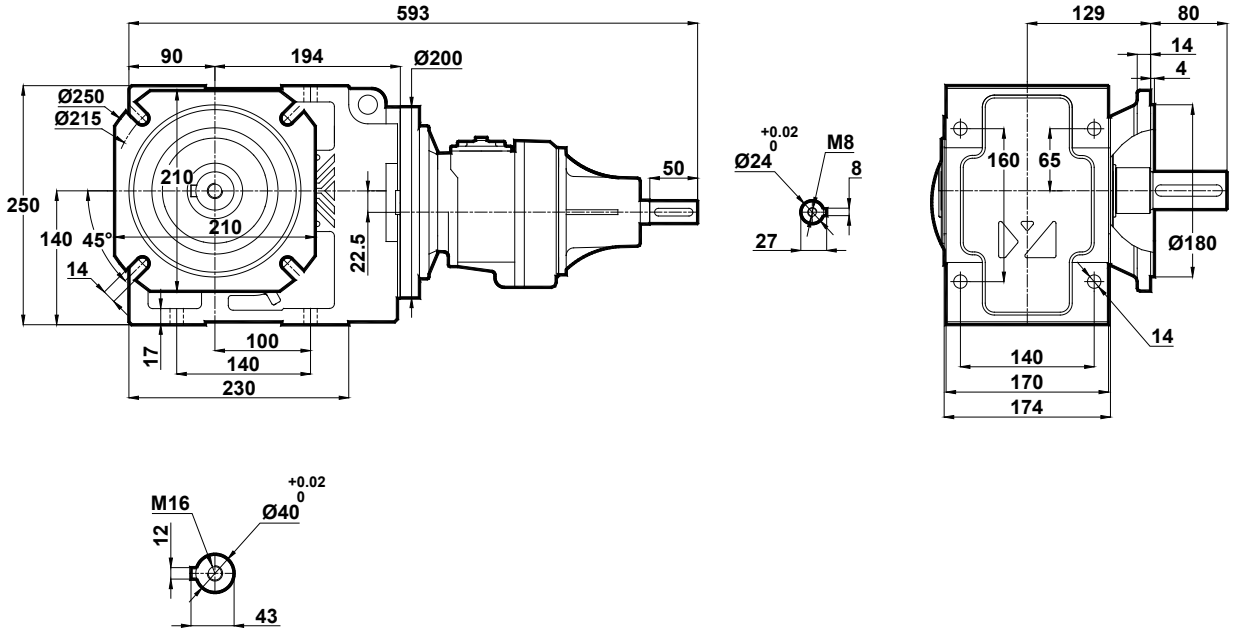

KT375.03  
KT376.03

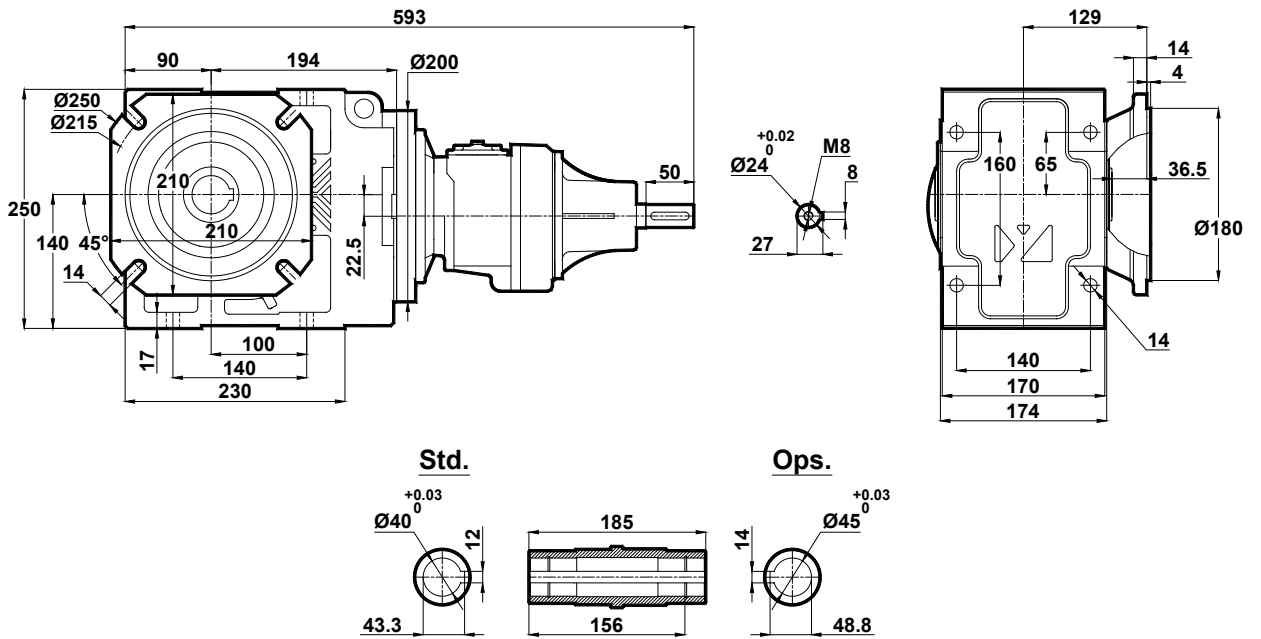





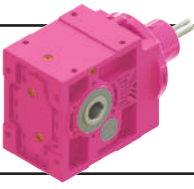

# Ölçü Sayfaları

## Dimension Pages

### Abmessungsseiten

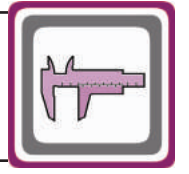

-Mil ucu çekirme deliği DIN 332 sayfa 2 / Tapped center hole to DIN 332, sheet 2 / Zentrierung mit gewinde DIN 332, Blatt 2

KT473.00

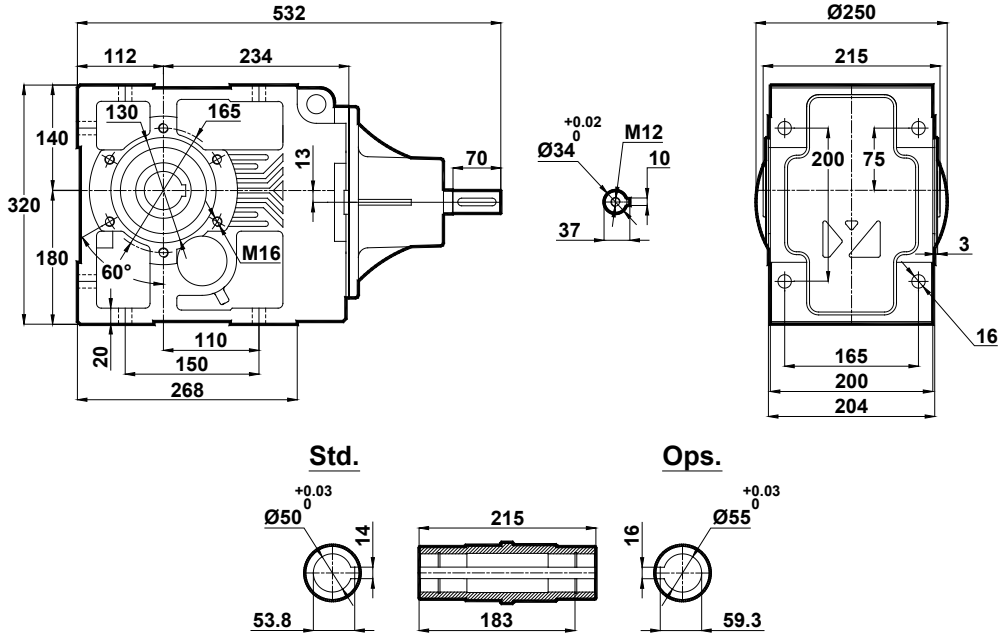

KT473.01

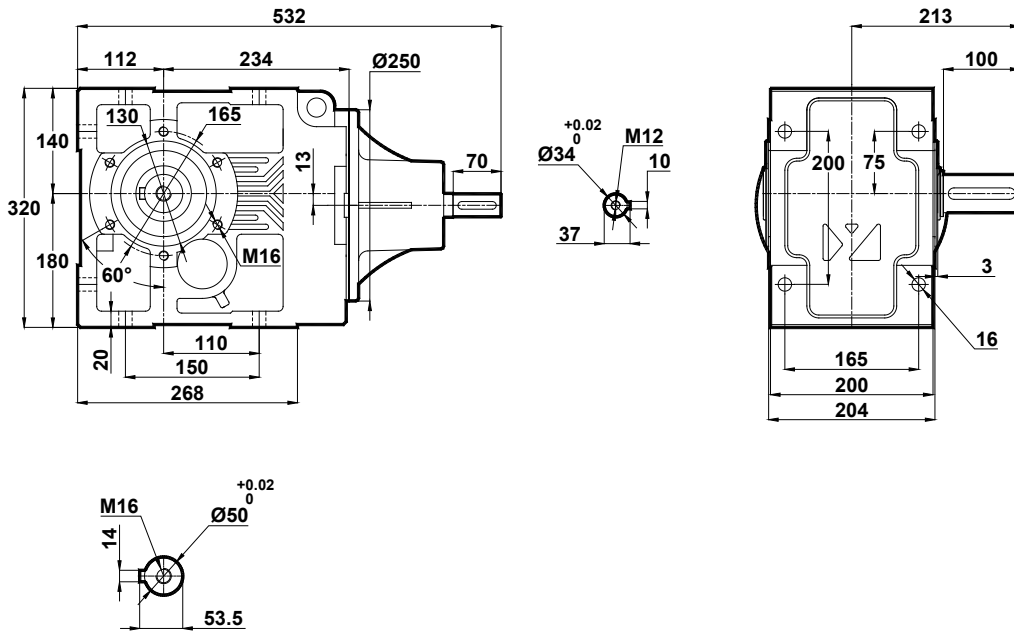

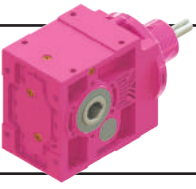

# Ölçü Sayfaları Dimension Pages Abmessungenseiten

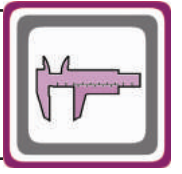

-Mil ucu çektirme deliği DIN 332 sayfa 2 / Tapped center hole to DIN 332, sheet 2 / Zentrierung mit gewinde DIN 332, Blatt 2

KT473.02

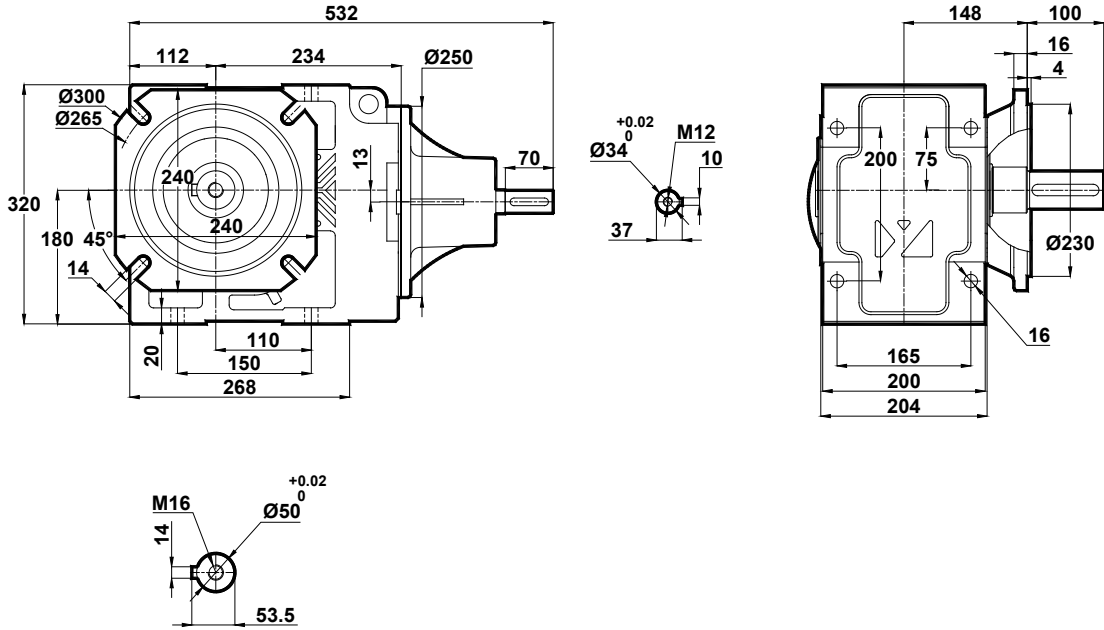

KT473.03

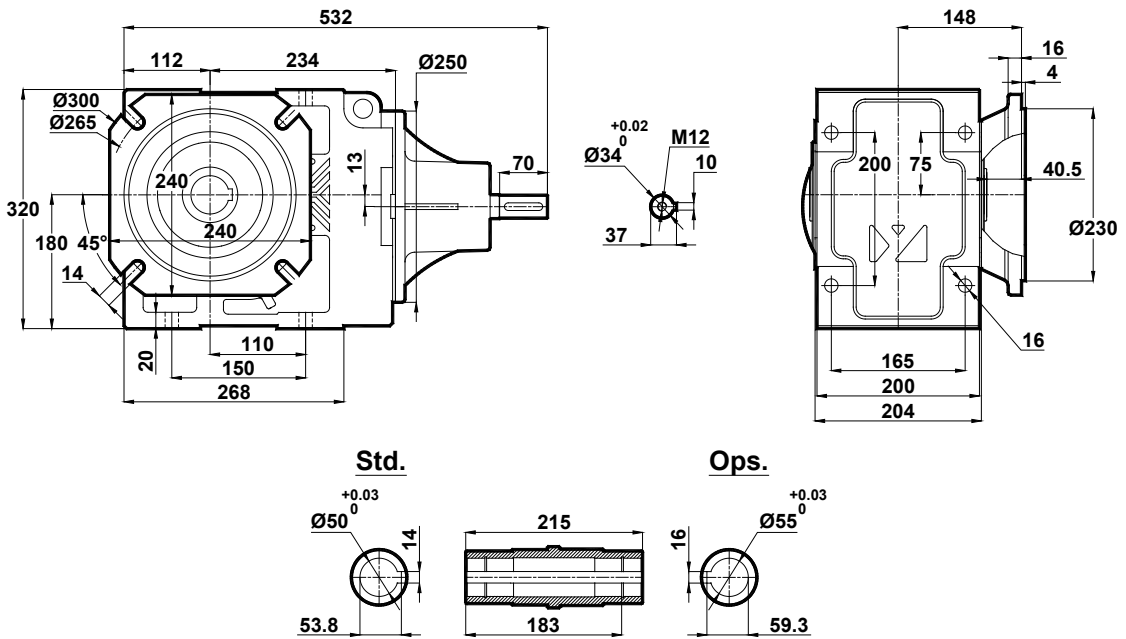

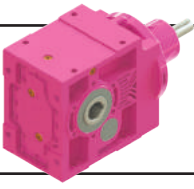

# Ölçü Sayfaları

## Dimension Pages

### Abmessungsseiten

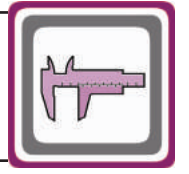

-Mil ucu çekirme deliği DIN 332 sayfa 2 / Tapped center hole to DIN 332, sheet 2 / Zentrierung mit gewinde DIN 332, Blatt 2

#### KT473.04

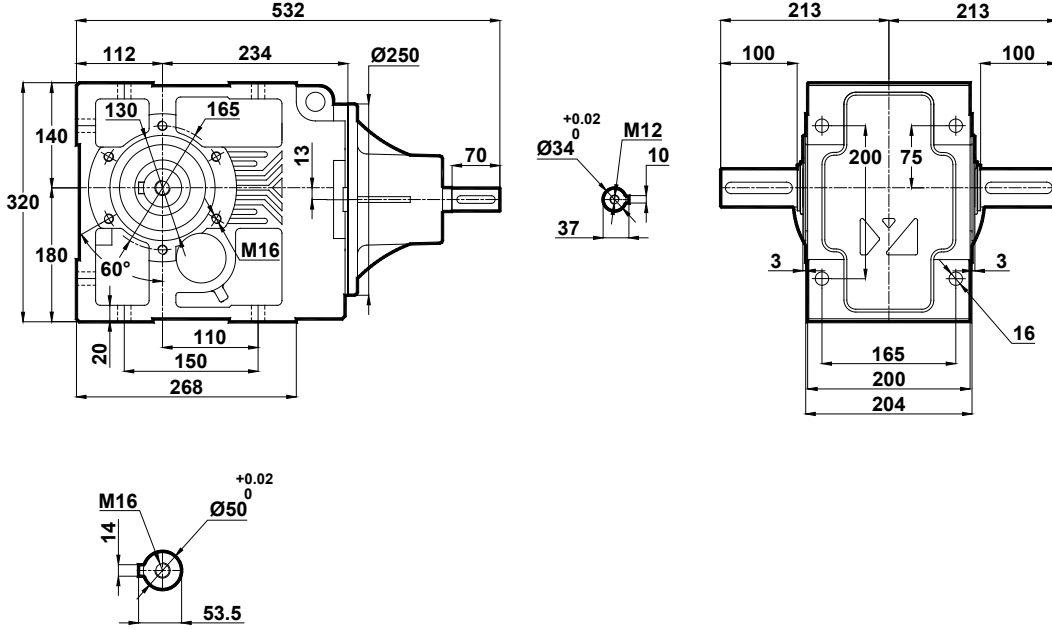

#### KT473.05

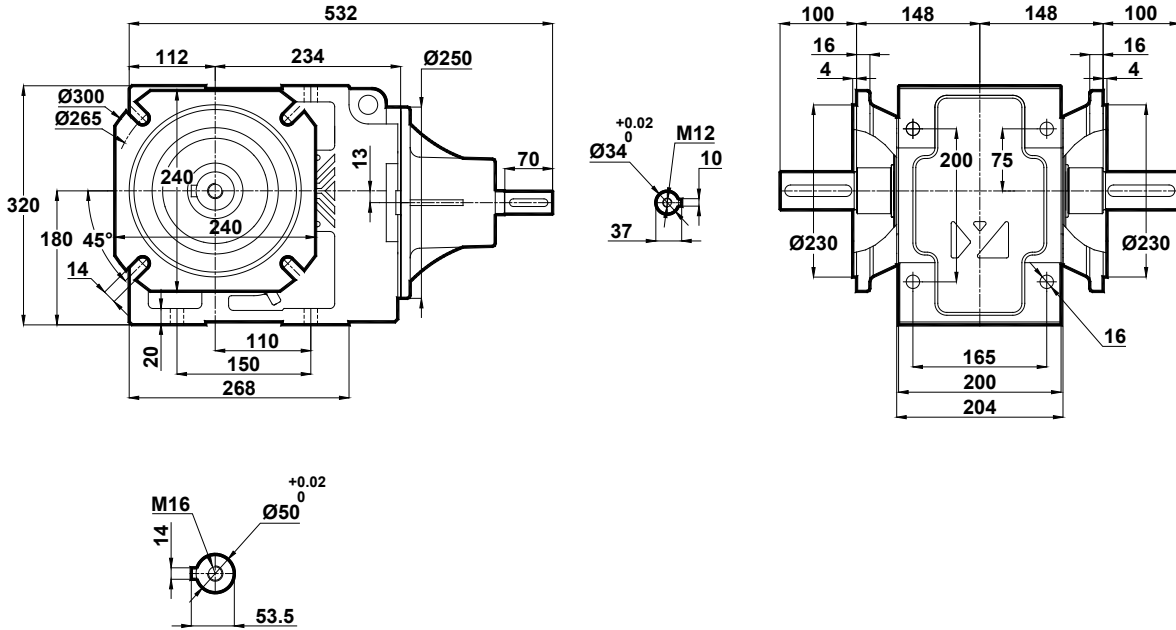

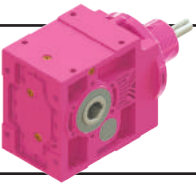

# Ölçü Sayfaları

## Dimension Pages

### Abmessungsseiten

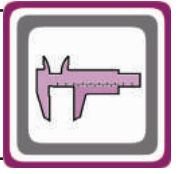

-Mil ucu çekirme deliği DIN 332 sayfa 2 / Tapped center hole to DIN 332, sheet 2 / Zentrierung mit gewinde DIN 332, Blatt 2

KT473.08

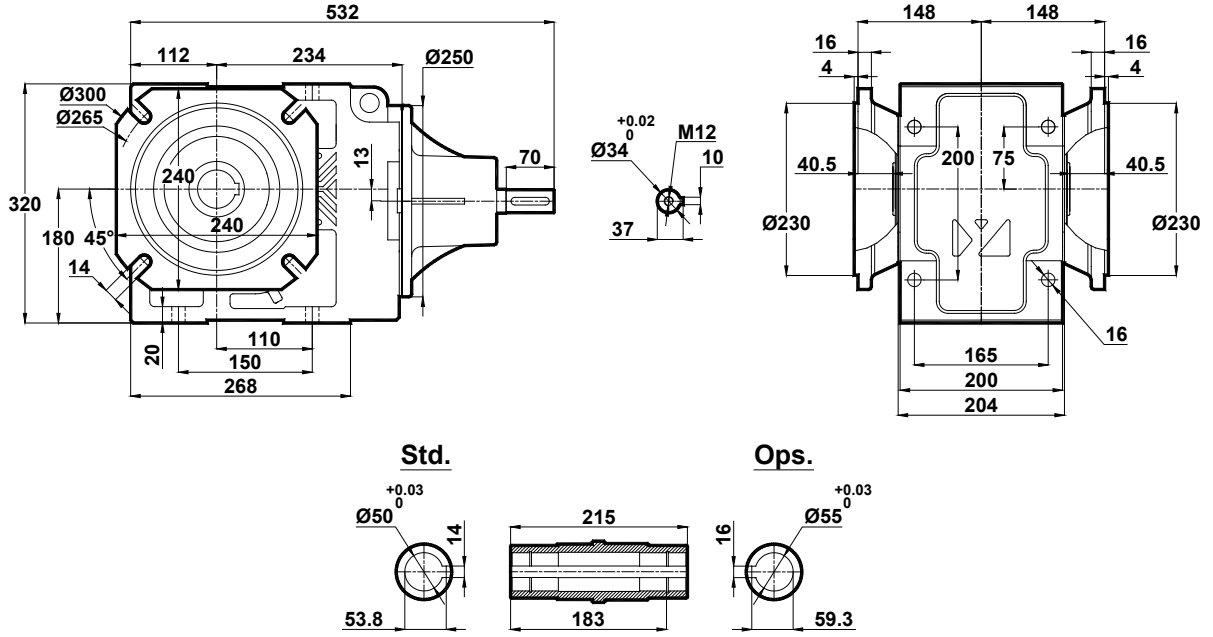

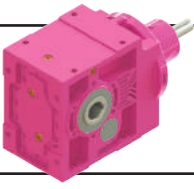

# Ölçü Sayfaları

## Dimension Pages

### Abmessungsseiten

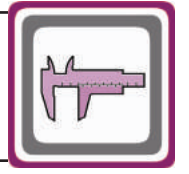

-Mil ucu çektirme deliği DIN 332 sayfa 2 / Tapped center hole to DIN 332, sheet 2 / Zentrierung mit gewinde DIN 332, Blatt 2

KT474.00

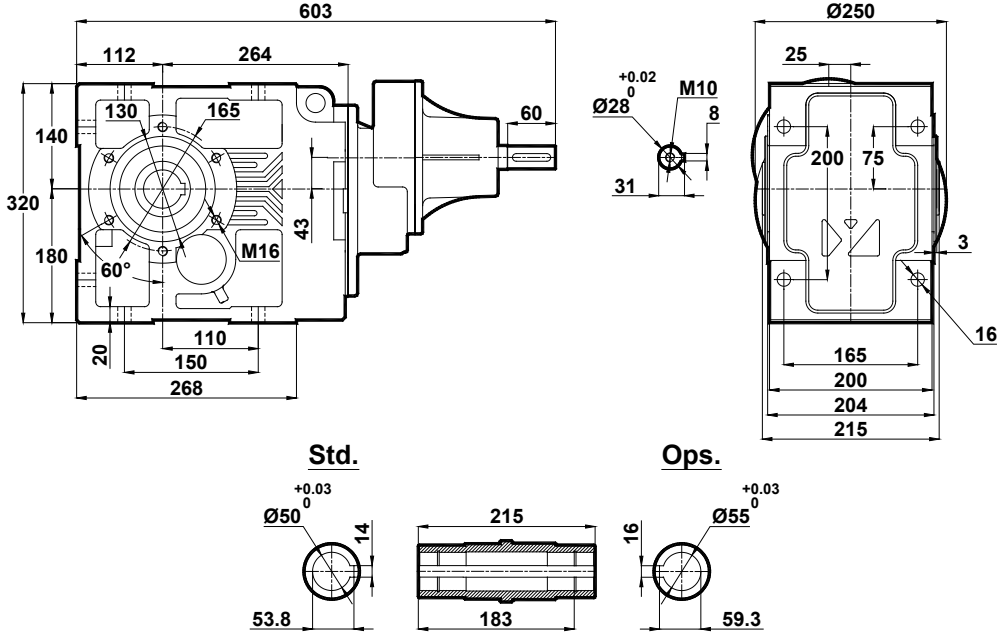

KT474.01

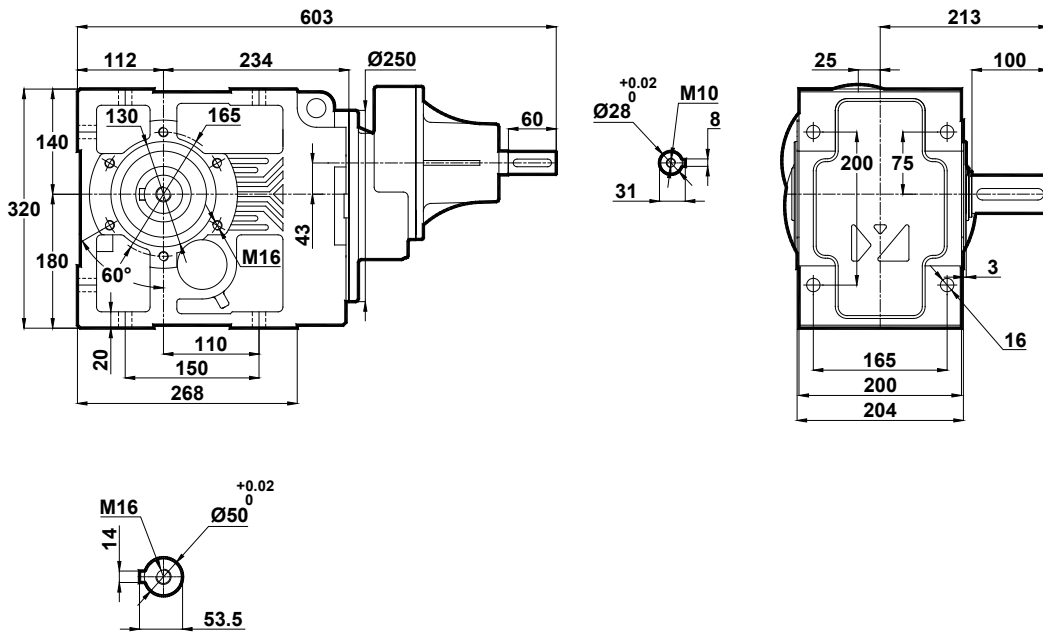

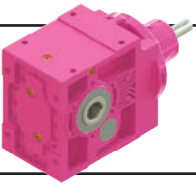

# Ölçü Sayfaları Dimension Pages Abmessungenseiten

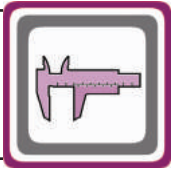

-Mil ucu çekirme deliği DIN 332 sayfa 2 / Tapped center hole to DIN 332, sheet 2 / Zentrierung mit gewinde DIN 332, Blatt 2

## KT474.02

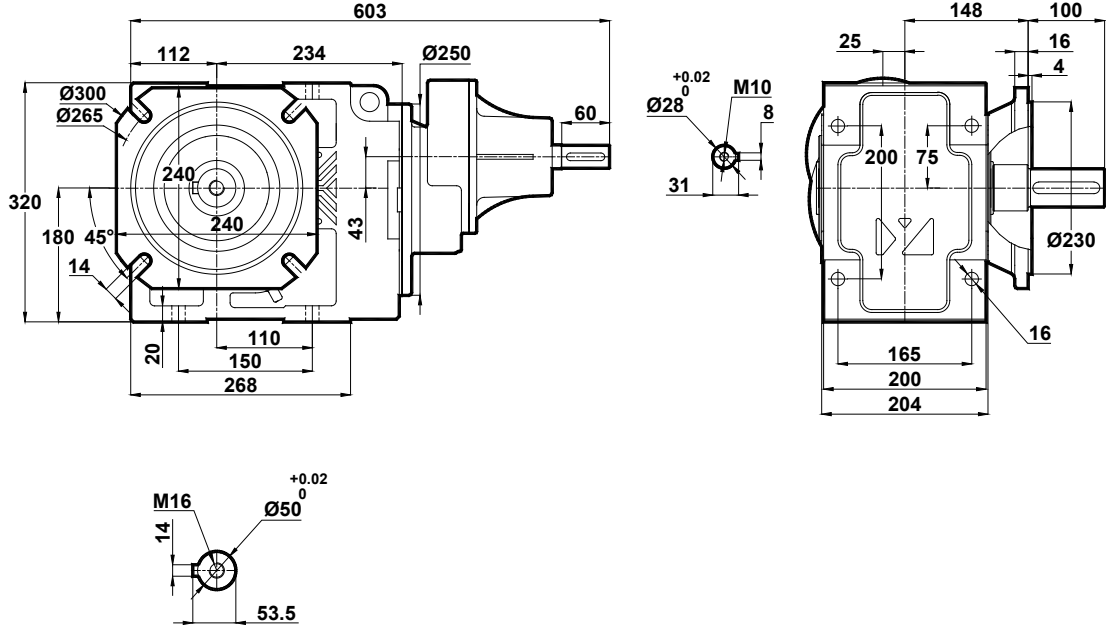

## KT474.03

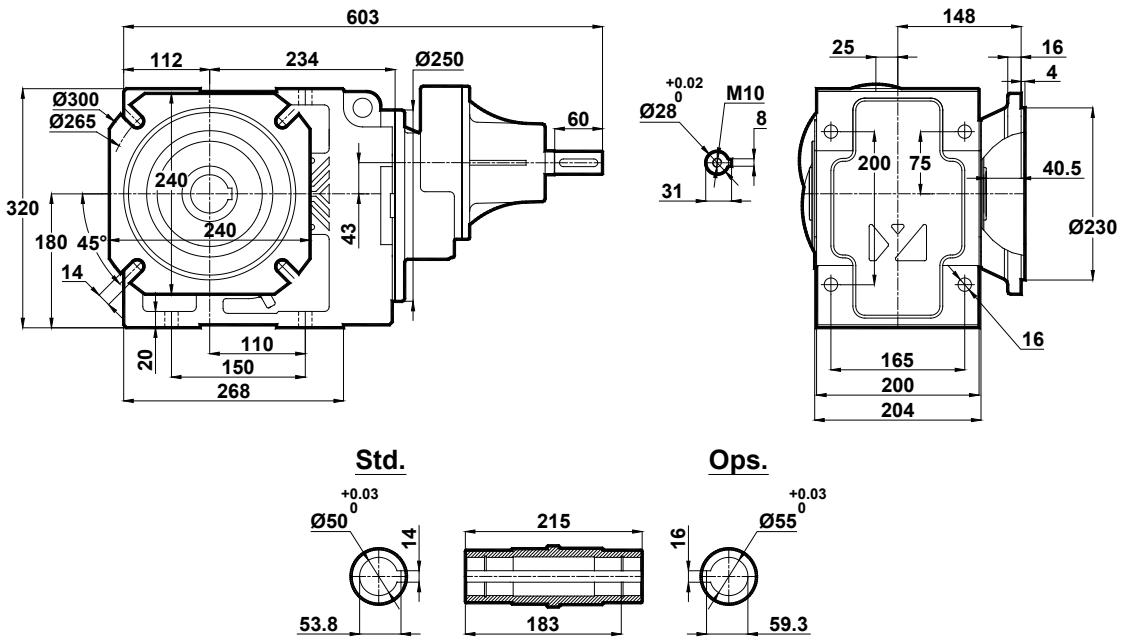

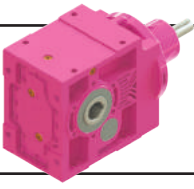

# Ölçü Sayfaları

## Dimension Pages

### Abmessungsseiten

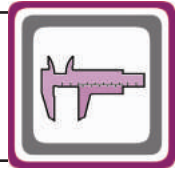

-Mil ucu çekirme deliği DIN 332 sayfa 2 / Tapped center hole to DIN 332, sheet 2 / Zentrierung mit gewinde DIN 332, Blatt 2

#### KT474.04

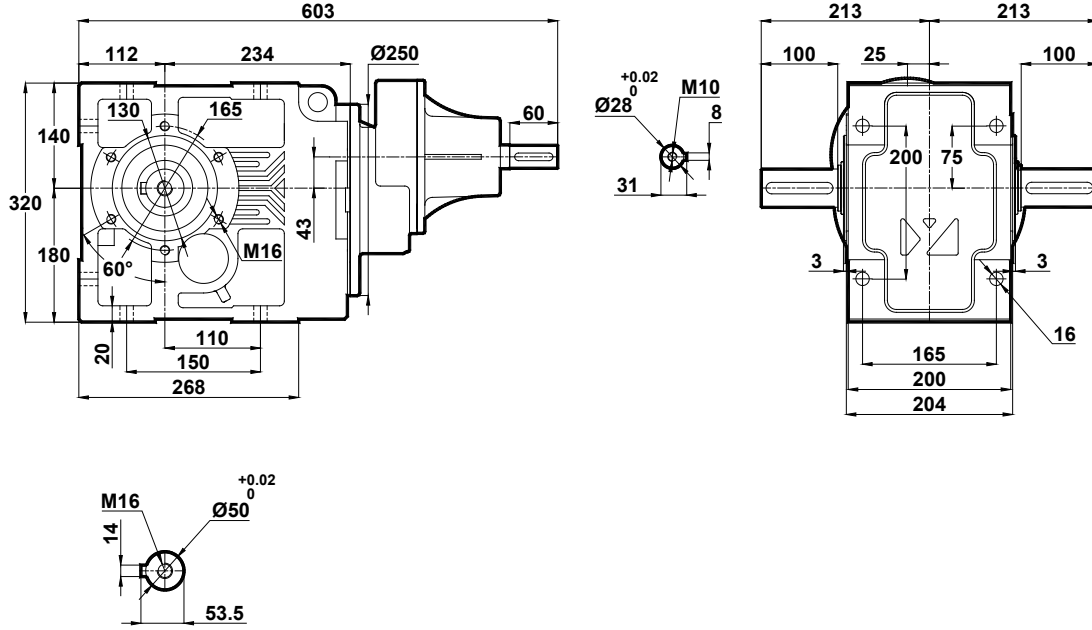

#### KT474.05

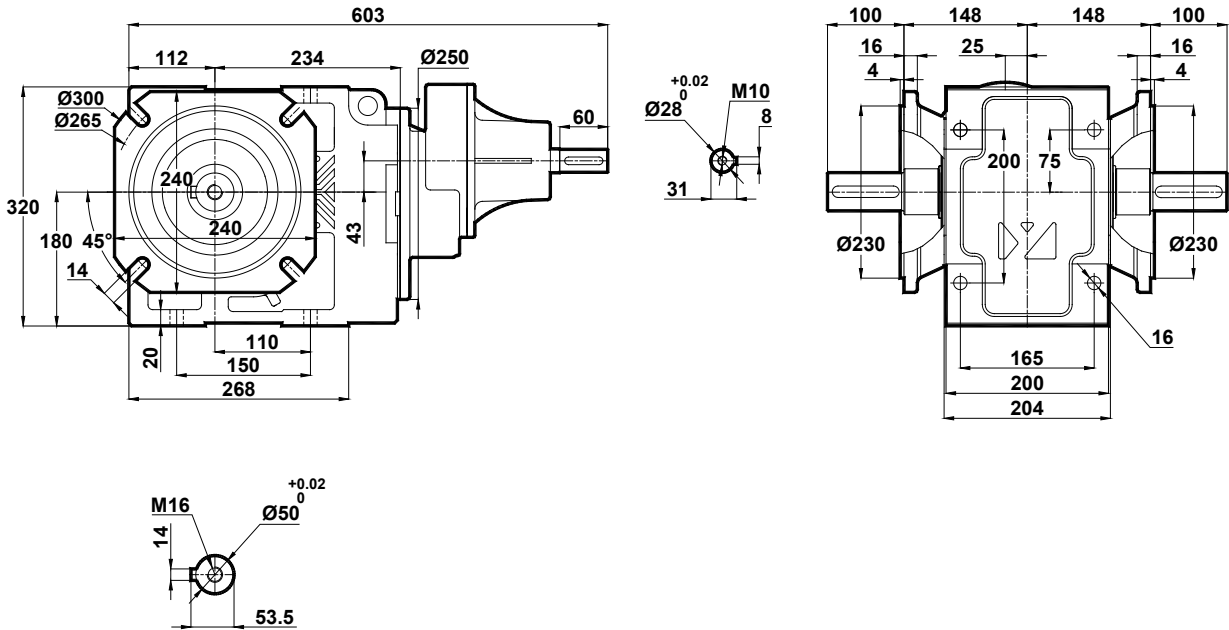

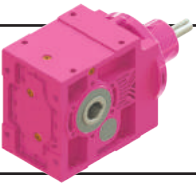

# Ölçü Sayfaları Dimension Pages Abmessungenseiten

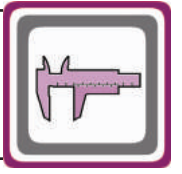

-Mil ucu çektirme deliği DIN 332 sayfa 2 / Tapped center hole to DIN 332, sheet 2 / Zentrierung mit gewinde DIN 332, Blatt 2

KT474.08

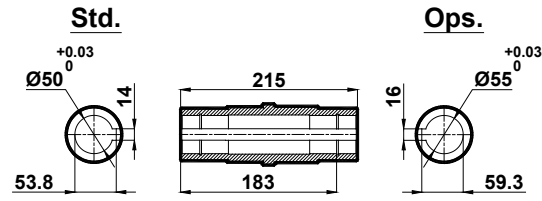
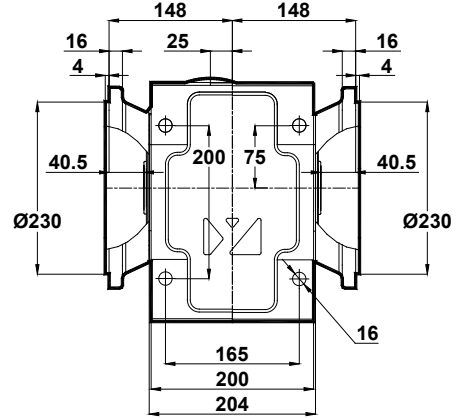
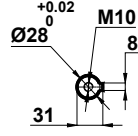
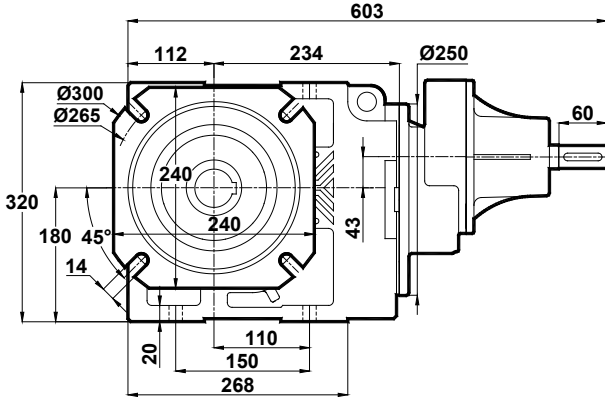

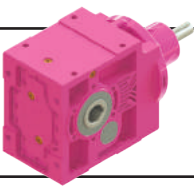

# Ölçü Sayfaları Dimension Pages Abmessungsseiten

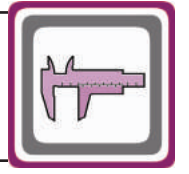

-Mil ucu çekirme deliği DIN 332 sayfa 2 / Tapped center hole to DIN 332, sheet 2 / Zentrierung mit gewinde DIN 332, Blatt 2

KT475.00  
KT476.00

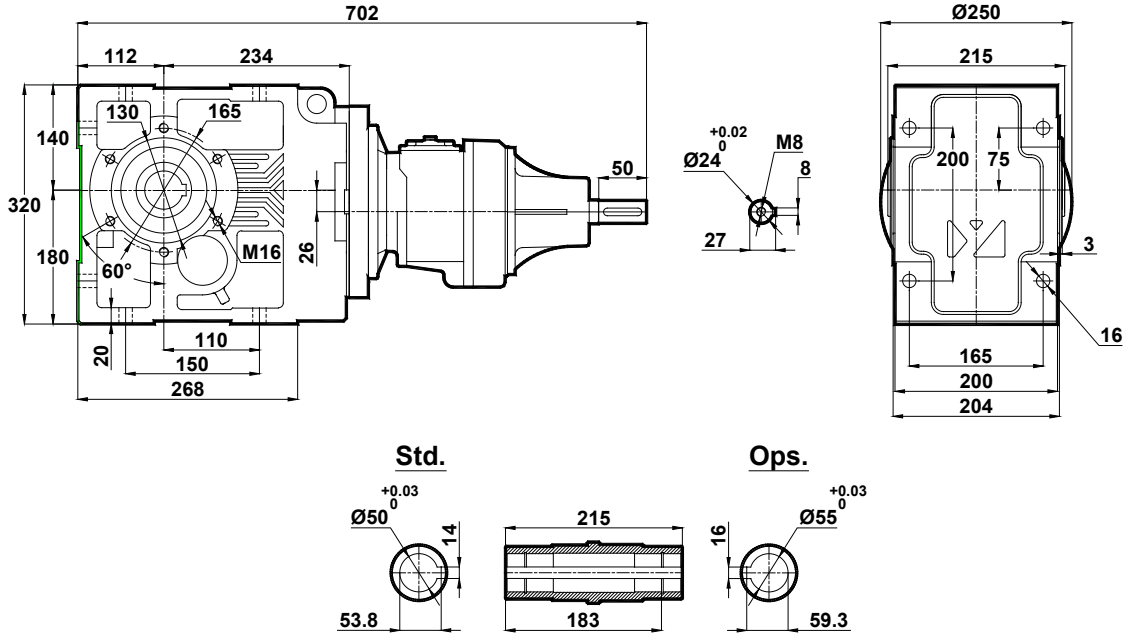

KT475.01  
KT476.01

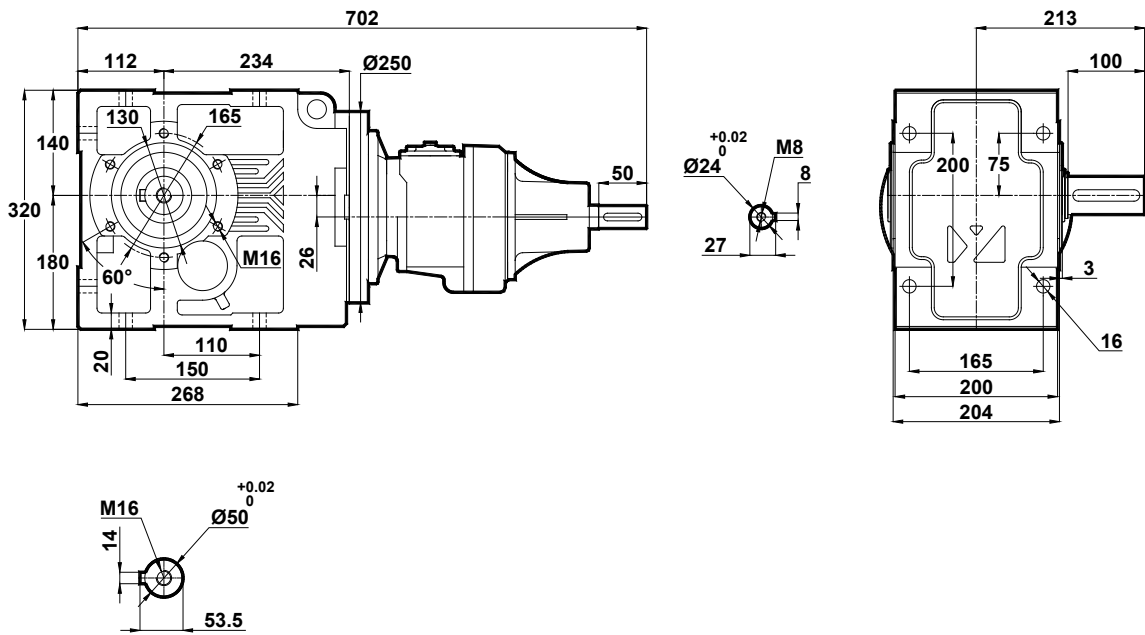



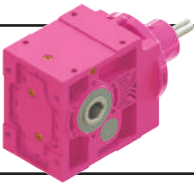

# Ölçü Sayfaları

## Dimension Pages

### Abmessungsseiten

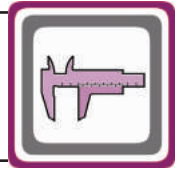

-Mil ucu çekirme deliği DIN 332 sayfa 2 / Tapped center hole to DIN 332, sheet 2 / Zentrierung mit gewinde DIN 332, Blatt 2

KT475.04  
KT476.04

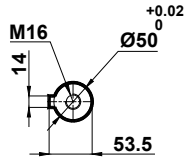
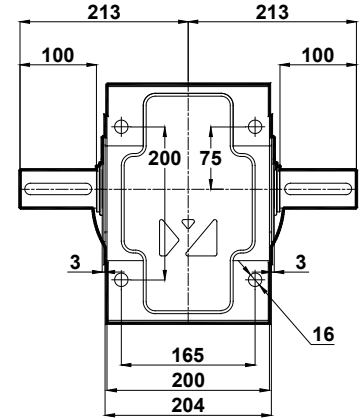
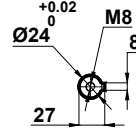
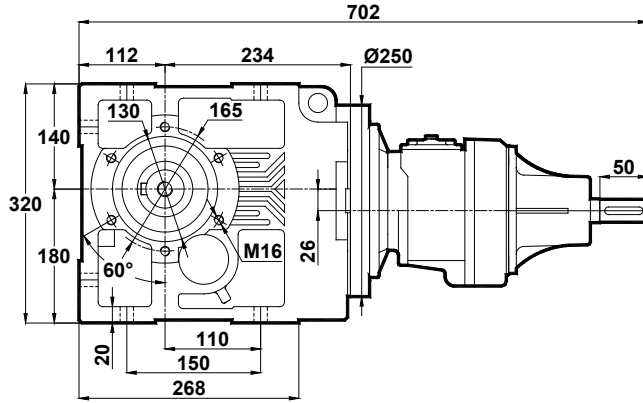

KT475.05  
KT476.05

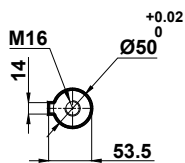
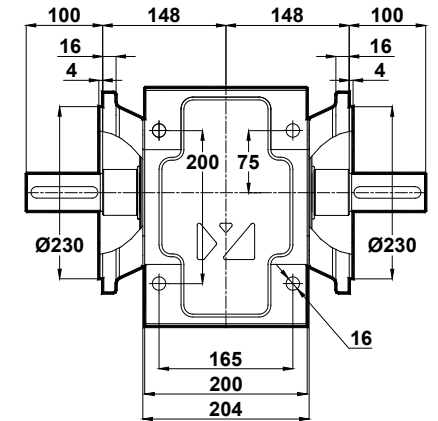
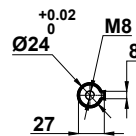
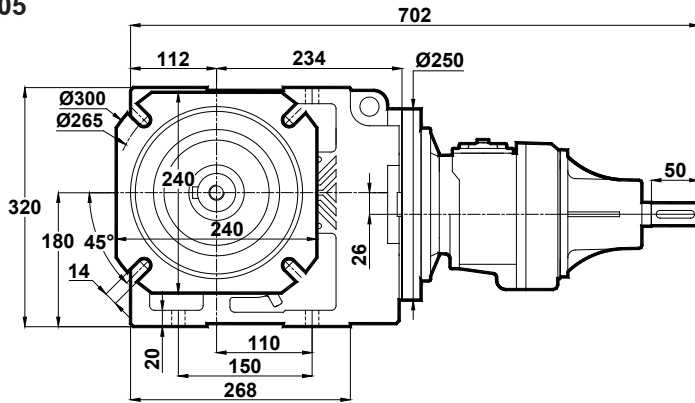

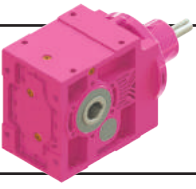

# Ölçü Sayfaları

## Dimension Pages

### Abmessungsseiten

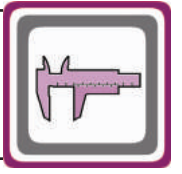

-Mil ucu çekirme deliği DIN 332 sayfa 2 / Tapped center hole to DIN 332, sheet 2 / Zentrierung mit gewinde DIN 332, Blatt 2

KT475.08  
KT476.08

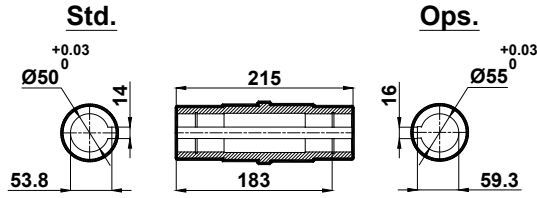
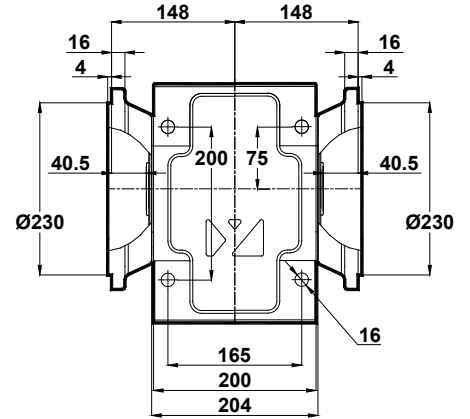
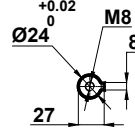
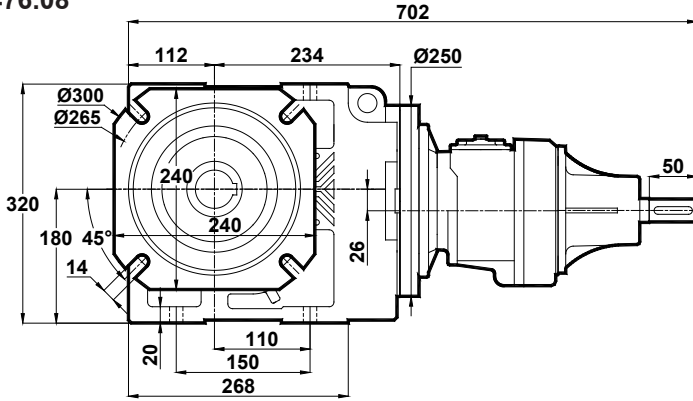

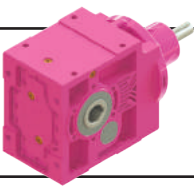

# Ölçü Sayfaları Dimension Pages Abmessungsseiten

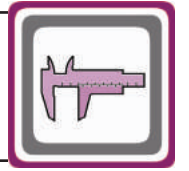

-Mil ucu çekirme deliği DIN 332 sayfa 2 / Tapped center hole to DIN 332, sheet 2 / Zentrierung mit gewinde DIN 332, Blatt 2

KT573.00

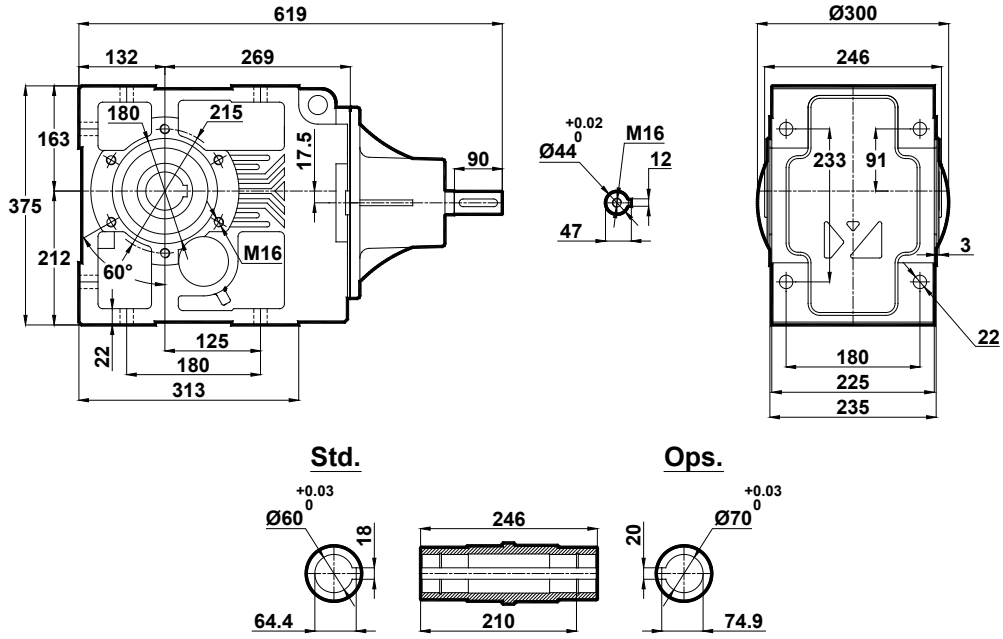

KT573.01

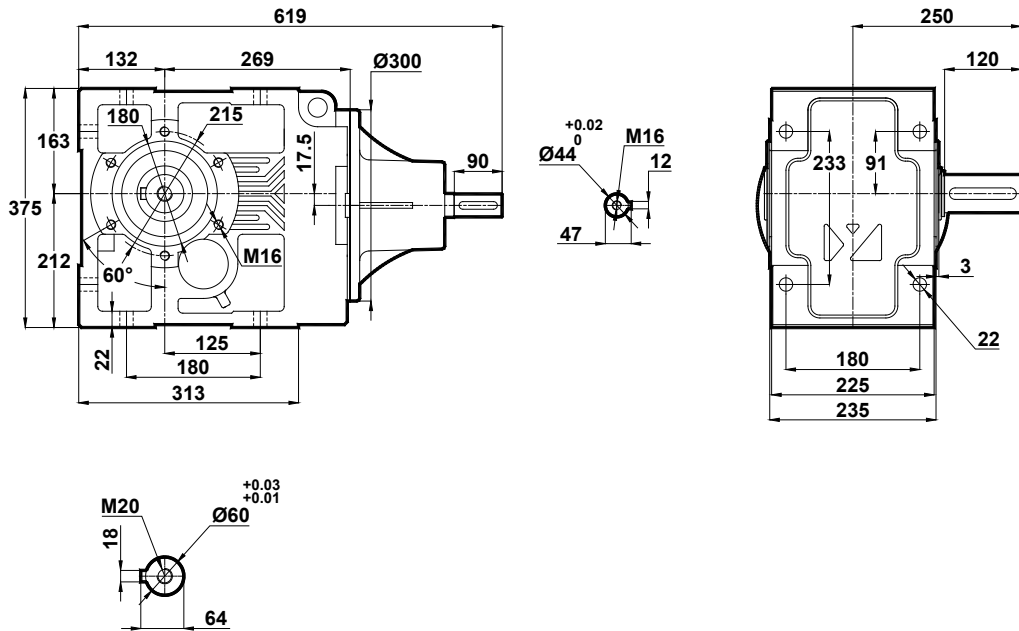



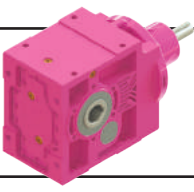

# Ölçü Sayfaları

## Dimension Pages

### Abmessungsseiten

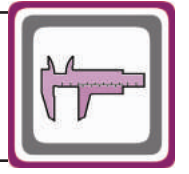

-Mil ucu çekirme deliği DIN 332 sayfa 2 / Tapped center hole to DIN 332, sheet 2 / Zentrierung mit gewinde DIN 332, Blatt 2

KT573.04

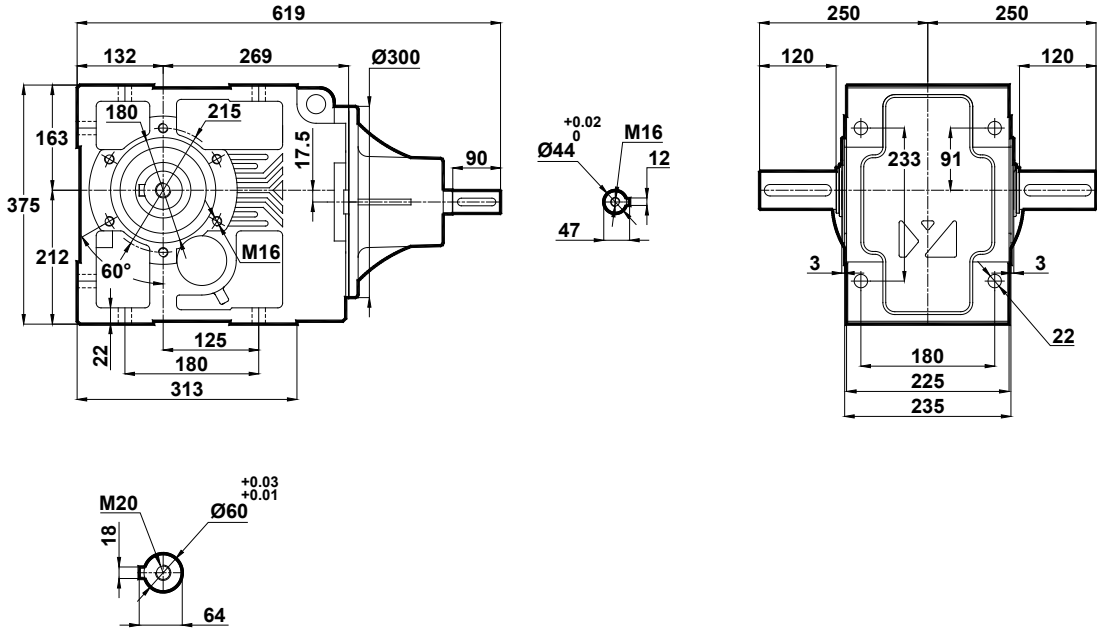

KT573.05

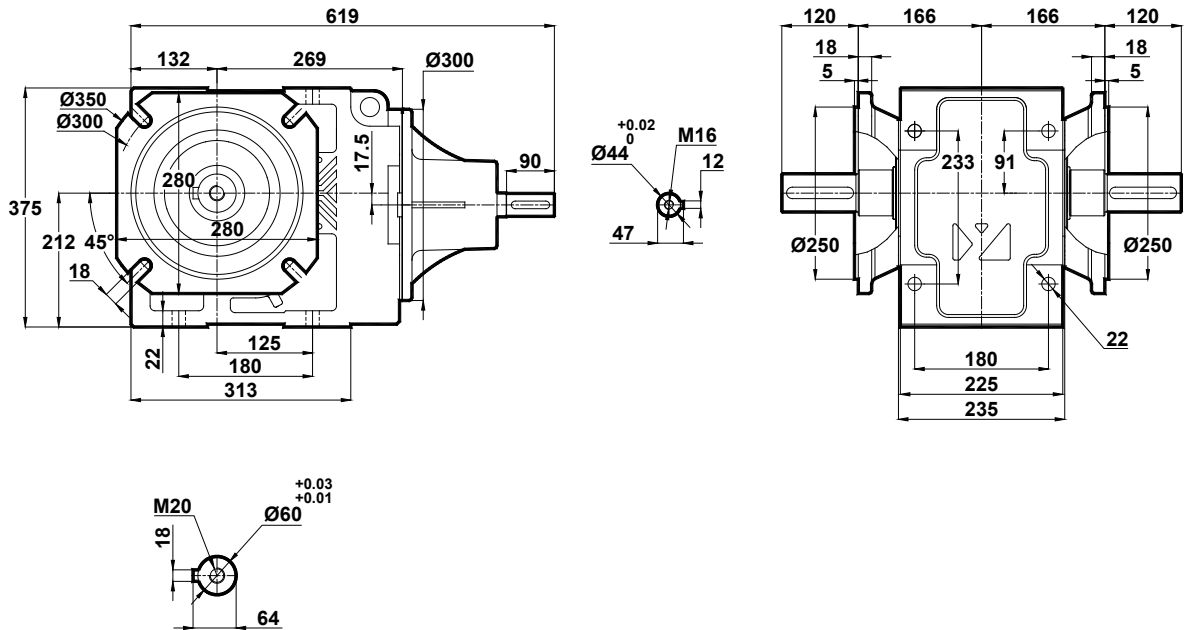

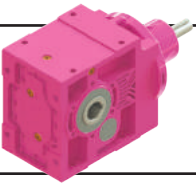

# Ölçü Sayfaları Dimension Pages Abmessungsseiten

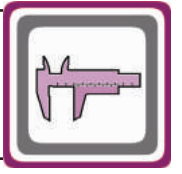

-Mil ucu çekirme deliği DIN 332 sayfa 2 / Tapped center hole to DIN 332, sheet 2 / Zentrierung mit gewinde DIN 332, Blatt 2

KT573.08

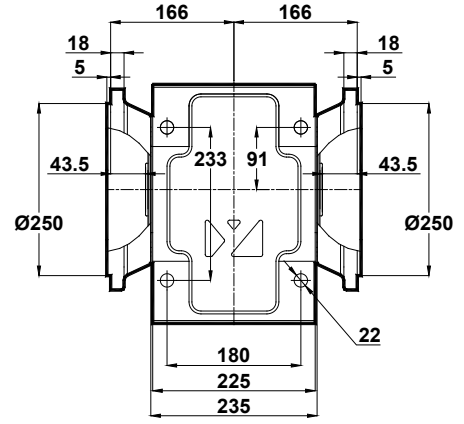
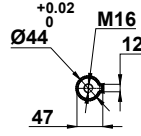
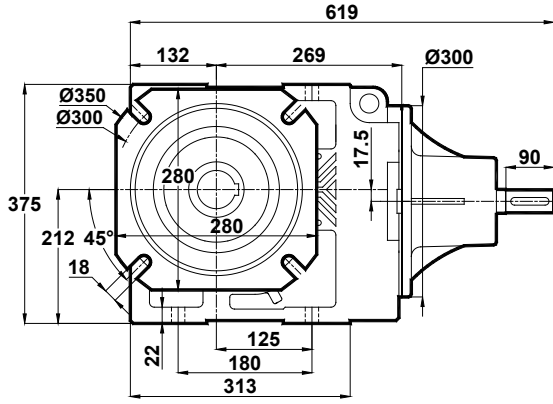

**Std.**

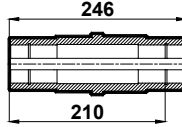
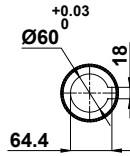

**Ops.**

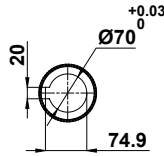

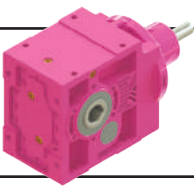

# Ölçü Sayfaları

## Dimension Pages

### Abmessungenseiten

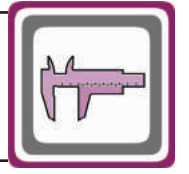

-Mil ucu çekirme deliği DIN 332 sayfa 2 / Tapped center hole to DIN 332, sheet 2 / Zentrierung mit gewinde DIN 332, Blatt 2

KT574.00

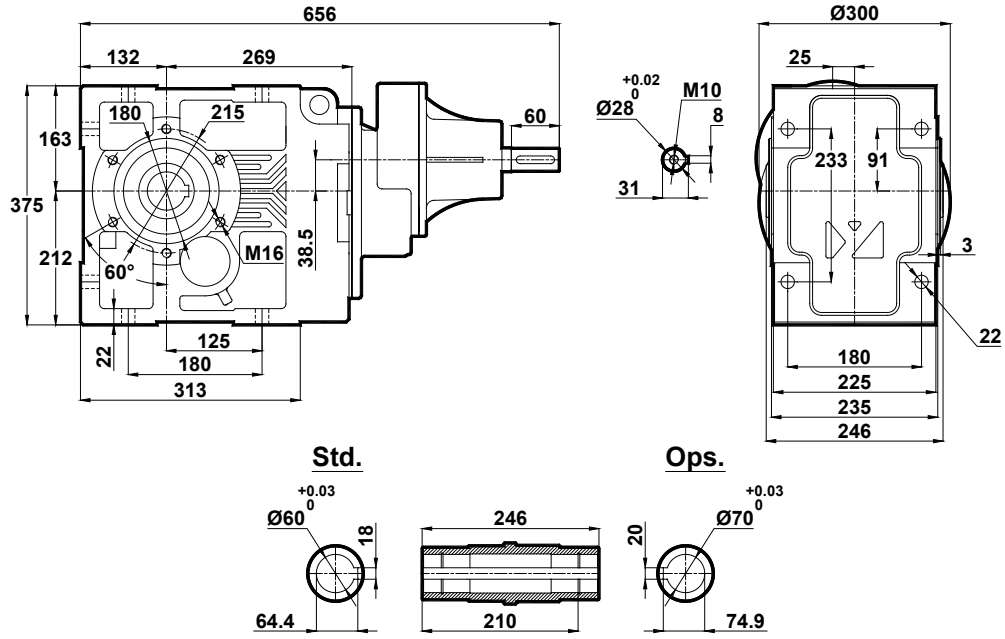

KT574.01

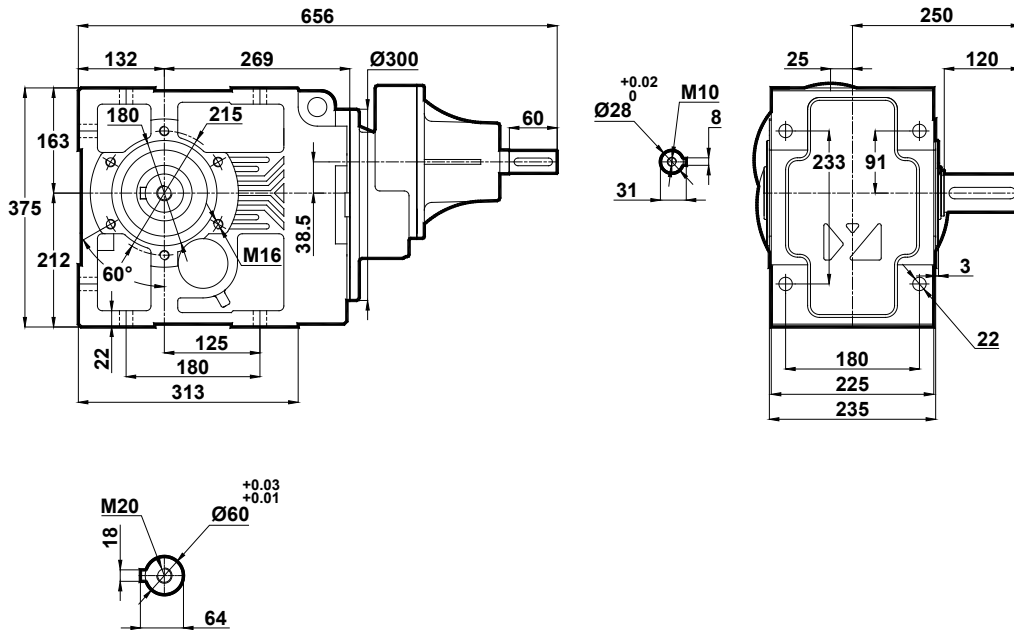

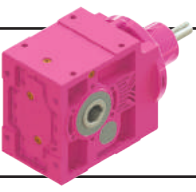

# Ölçü Sayfaları Dimension Pages Abmessungenseiten

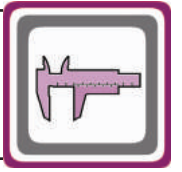

-Mil ucu çekirme deliği DIN 332 sayfa 2 / Tapped center hole to DIN 332, sheet 2 / Zentrierung mit gewinde DIN 332, Blatt 2

KT574.02

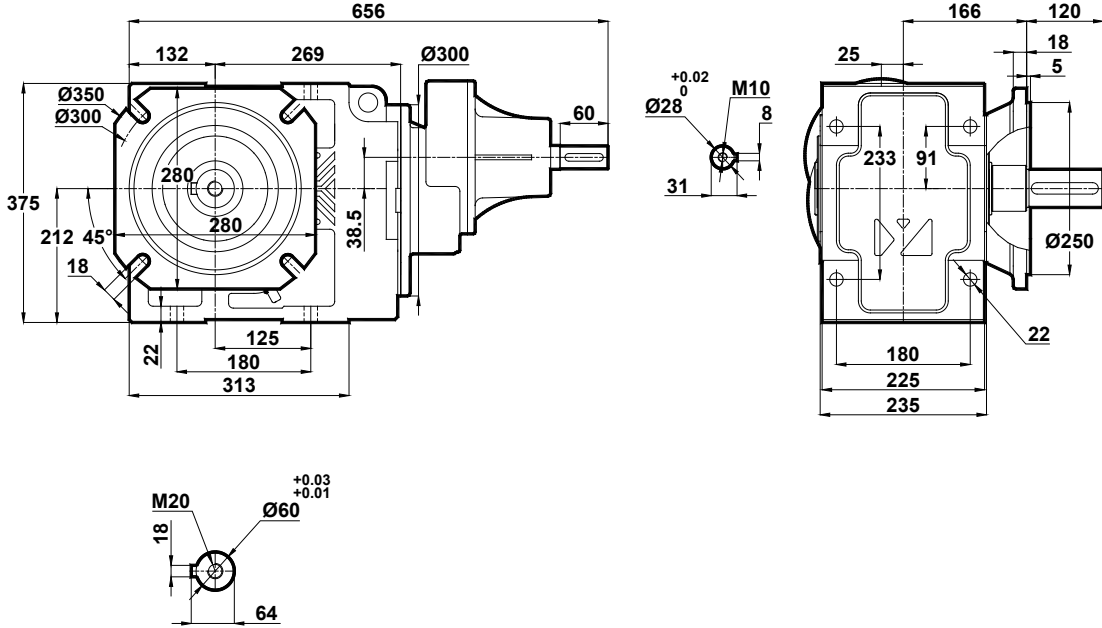

KT574.03

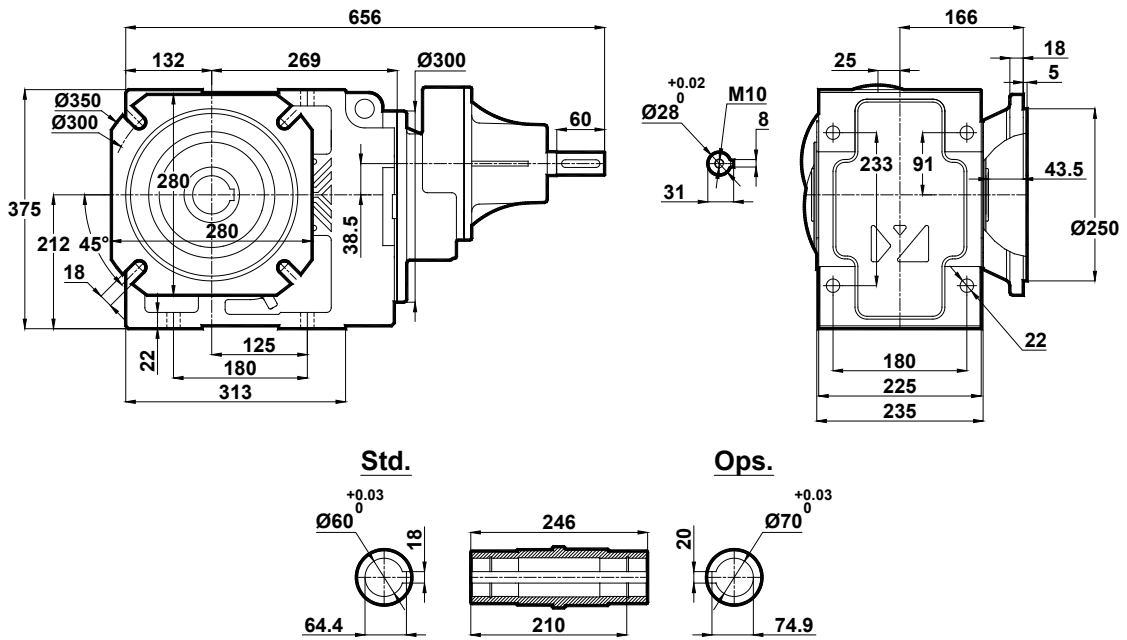

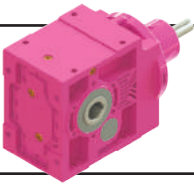

# Ölçü Sayfaları

## Dimension Pages

### Abmessungsseiten

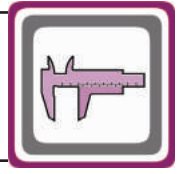

-Mil ucu çekirme deliği DIN 332 sayfa 2 / Tapped center hole to DIN 332, sheet 2 / Zentrierung mit gewinde DIN 332, Blatt 2

KT574.04

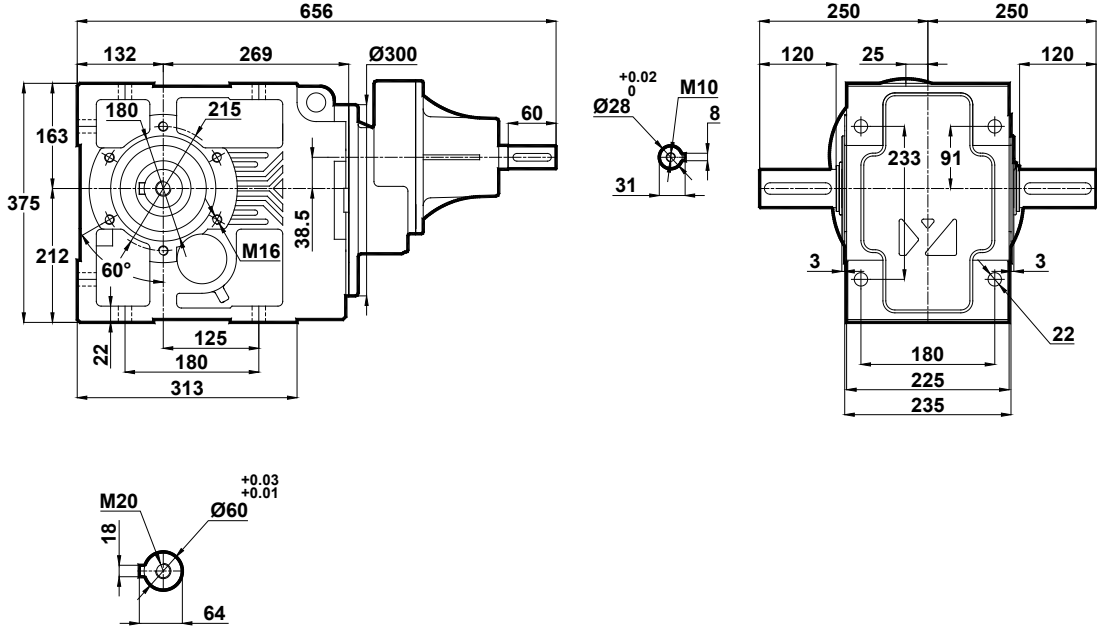

KT574.05

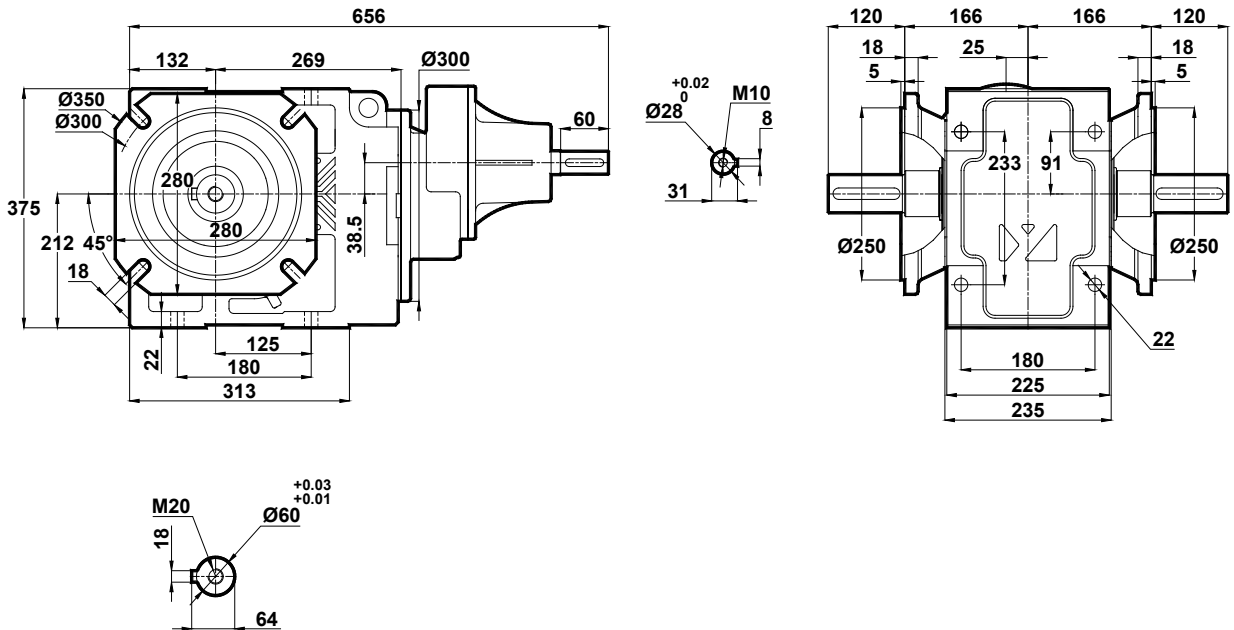



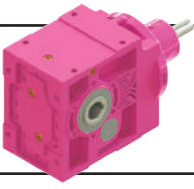

# Ölçü Sayfaları

## Dimension Pages

### Abmessungsseiten

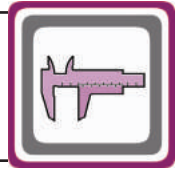

-Mil ucu çekirme deliği DIN 332 sayfa 2 / Tapped center hole to DIN 332, sheet 2 / Zentrierung mit gewinde DIN 332, Blatt 2

KT575.00  
KT576.00

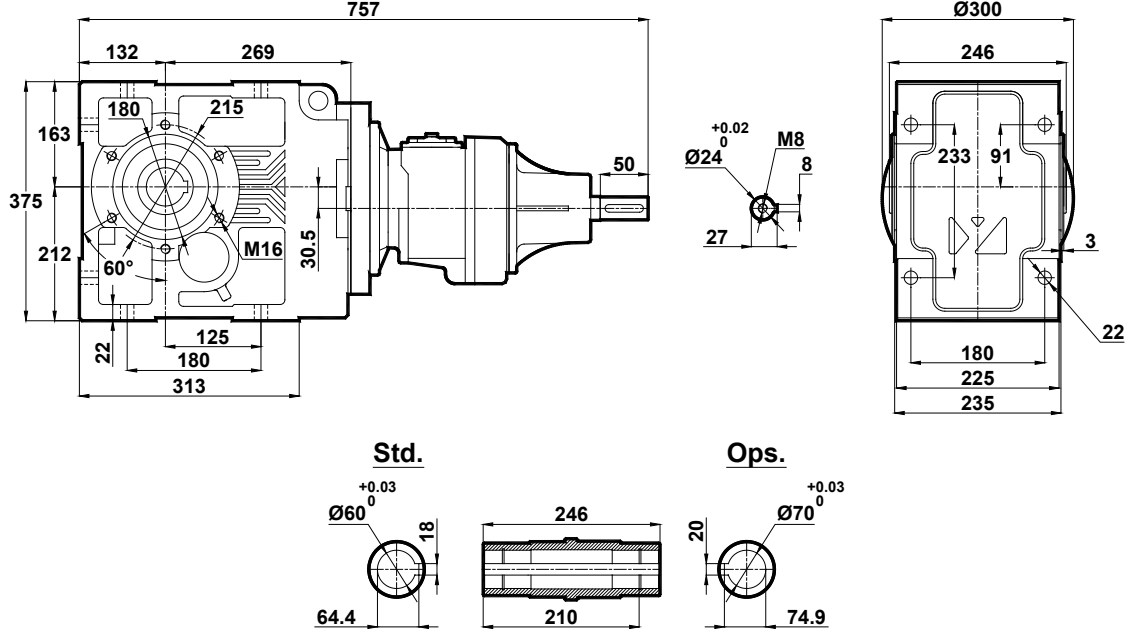

KT575.01  
KT576.01

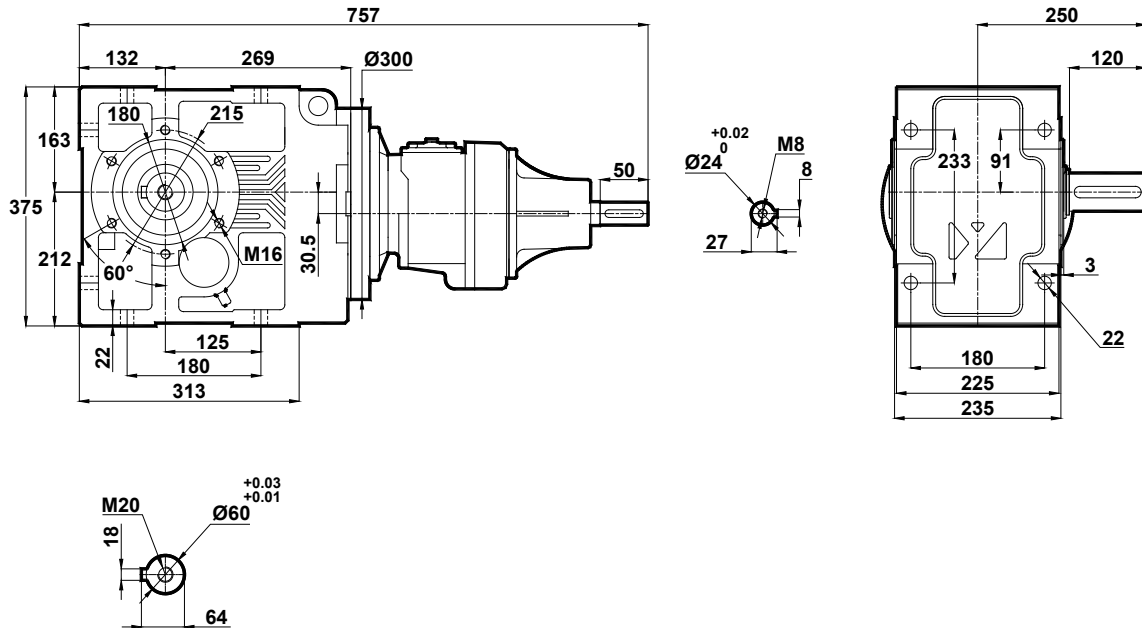

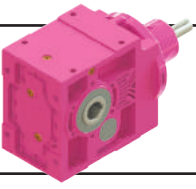

# Ölçü Sayfaları Dimension Pages Abmessungenseiten

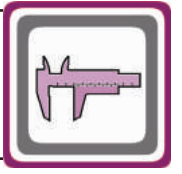

-Mil ucu çekirme deliği DIN 332 sayfa 2 / Tapped center hole to DIN 332, sheet 2 / Zentrierung mit gewinde DIN 332, Blatt 2

KT575.02  
KT576.02

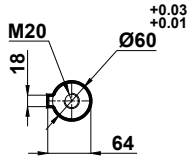
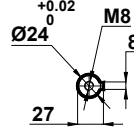
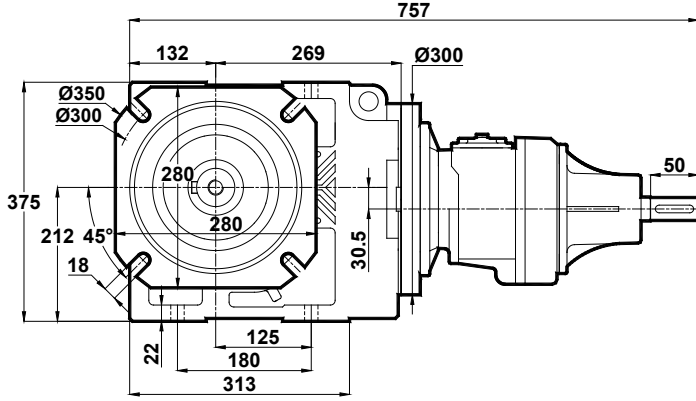

KT575.03  
KT576.03

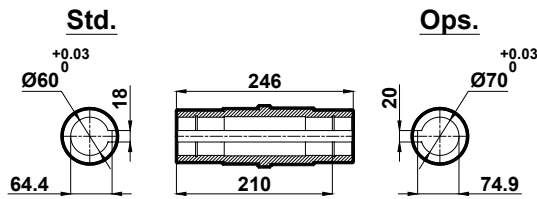
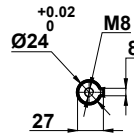
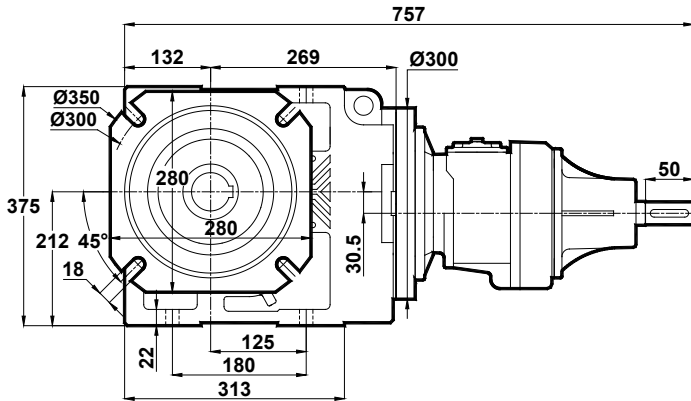

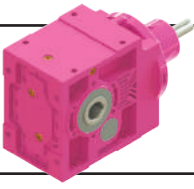

# Ölçü Sayfaları

## Dimension Pages

### Abmessungsseiten

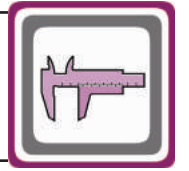

-Mil ucu çekirme deliği DIN 332 sayfa 2 / Tapped center hole to DIN 332, sheet 2 / Zentrierung mit gewinde DIN 332, Blatt 2

KT575.04  
KT576.04

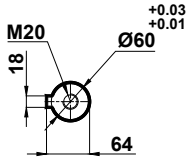
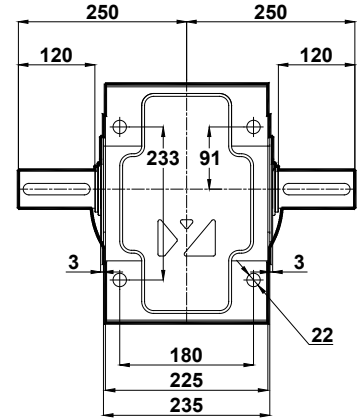
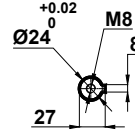
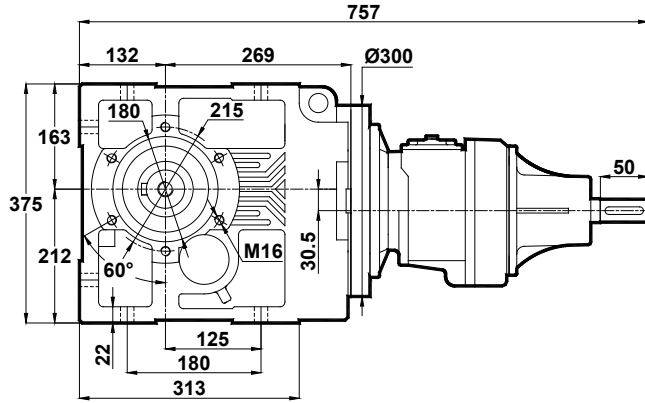

KT575.05  
KT576.05

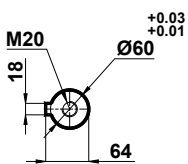
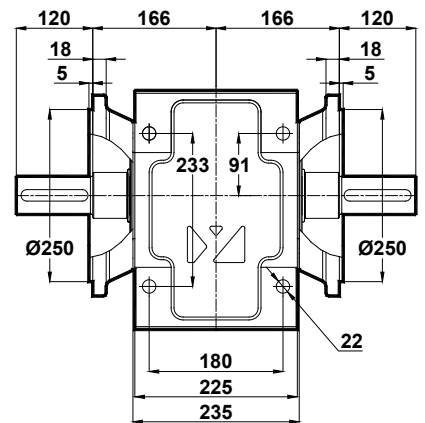
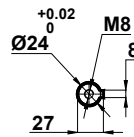
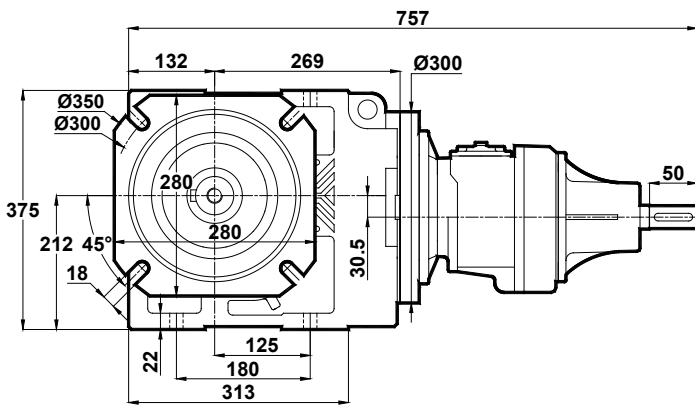

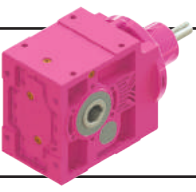

# Ölçü Sayfaları

## Dimension Pages

### Abmessungsseiten

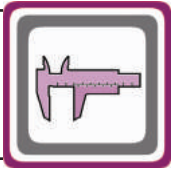

-Mil ucu çekirme deliği DIN 332 sayfa 2 / Tapped center hole to DIN 332, sheet 2 / Zentrierung mit gewinde DIN 332, Blatt 2

KT575.08  
KT576.08

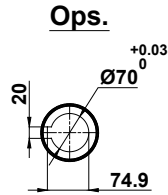
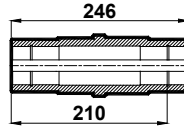
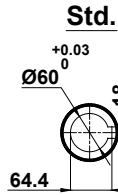
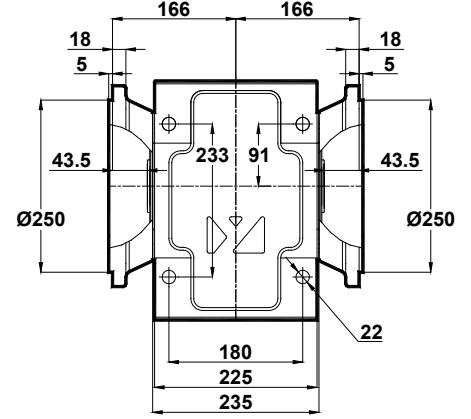
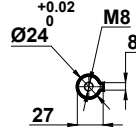
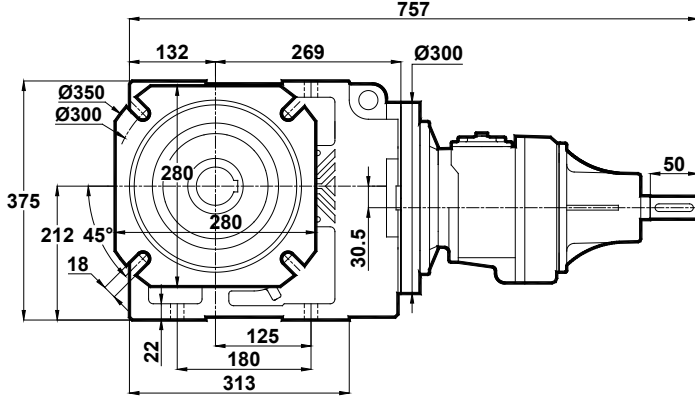

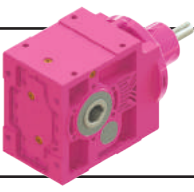

# Ölçü Sayfaları

## Dimension Pages

### Abmessungsseiten

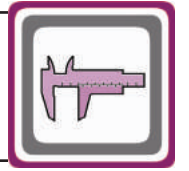

-Mil ucu çekirme deliği DIN 332 sayfa 2 / Tapped center hole to DIN 332, sheet 2 / Zentrierung mit gewinde DIN 332, Blatt 2

KT673.00

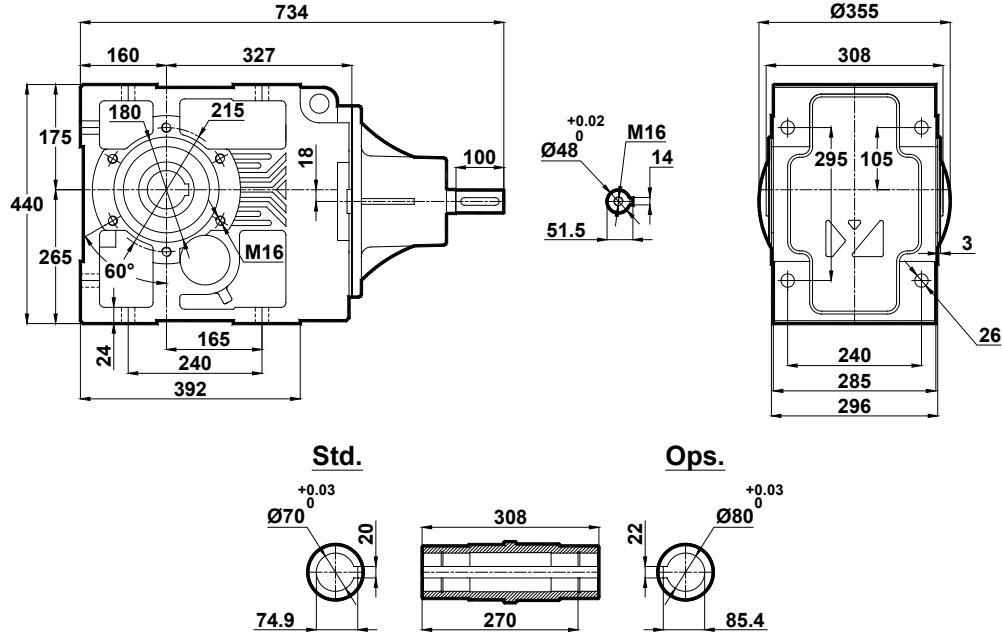

KT673.01

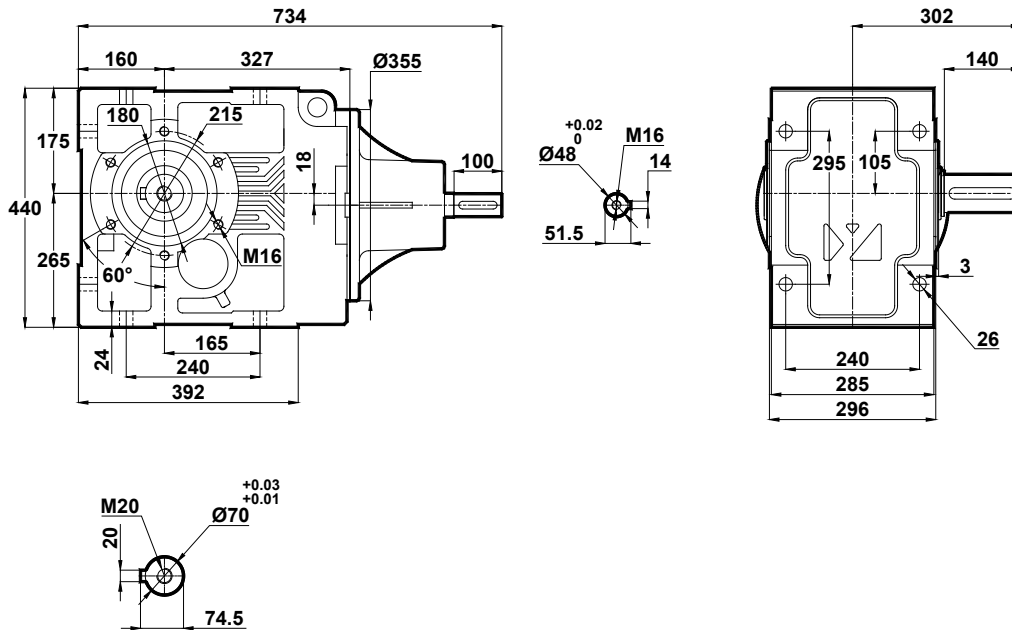

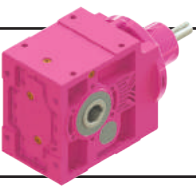

# Ölçü Sayfaları Dimension Pages Abmessungenseiten

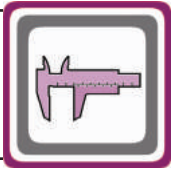

-Mil ucu çekirme deliği DIN 332 sayfa 2 / Tapped center hole to DIN 332, sheet 2 / Zentrierung mit gewinde DIN 332, Blatt 2

KT673.02

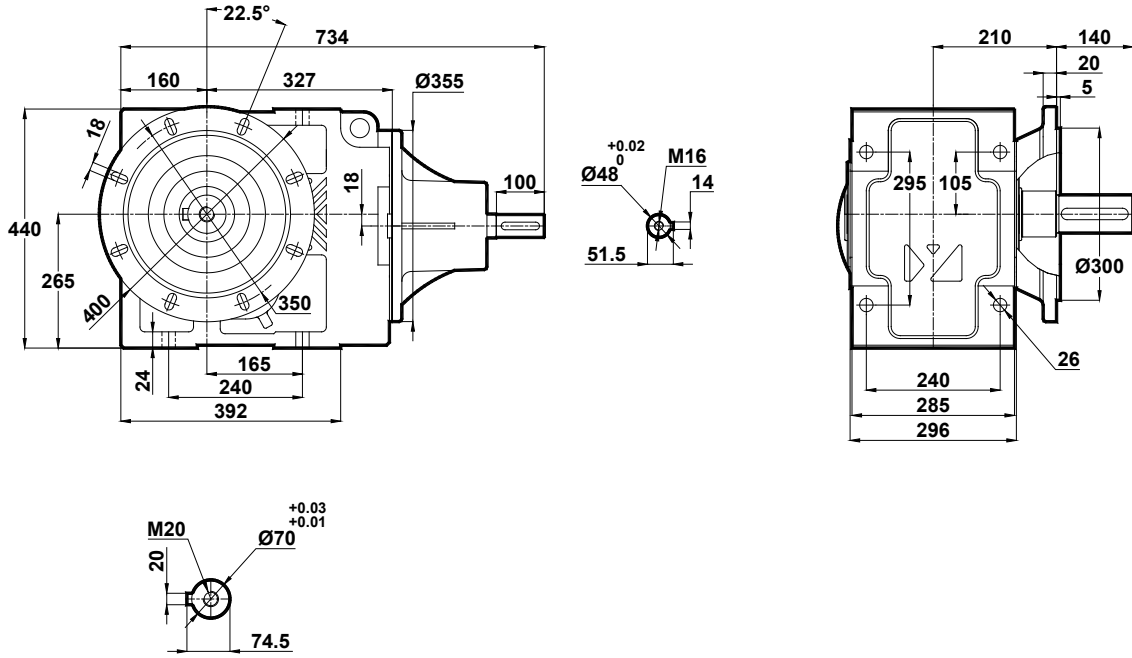

KT673.03

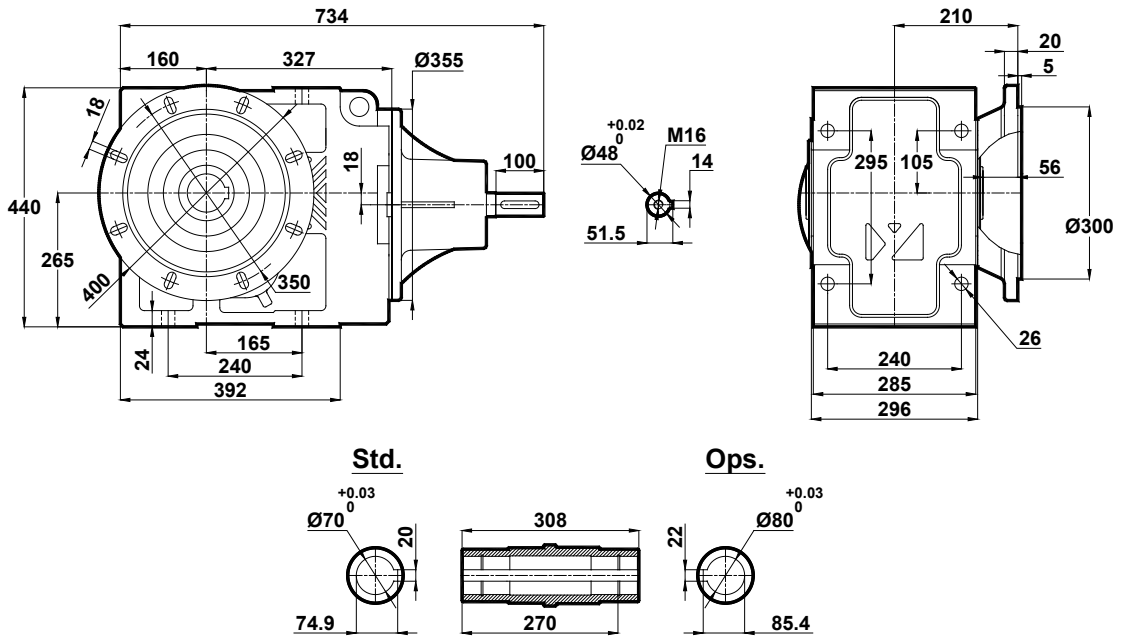

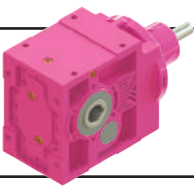

# Ölçü Sayfaları Dimension Pages Abmessungenseiten

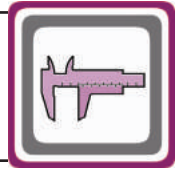

-Mil ucu çekirme deliği DIN 332 sayfa 2 / Tapped center hole to DIN 332, sheet 2 / Zentrierung mit gewinde DIN 332, Blatt 2

KT673.04

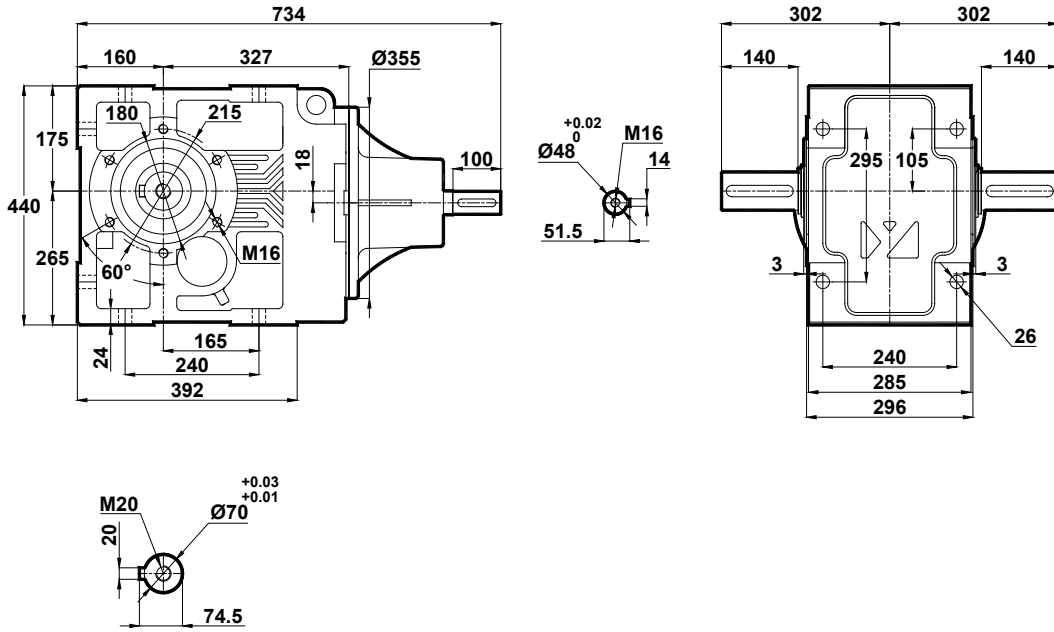

KT673.05

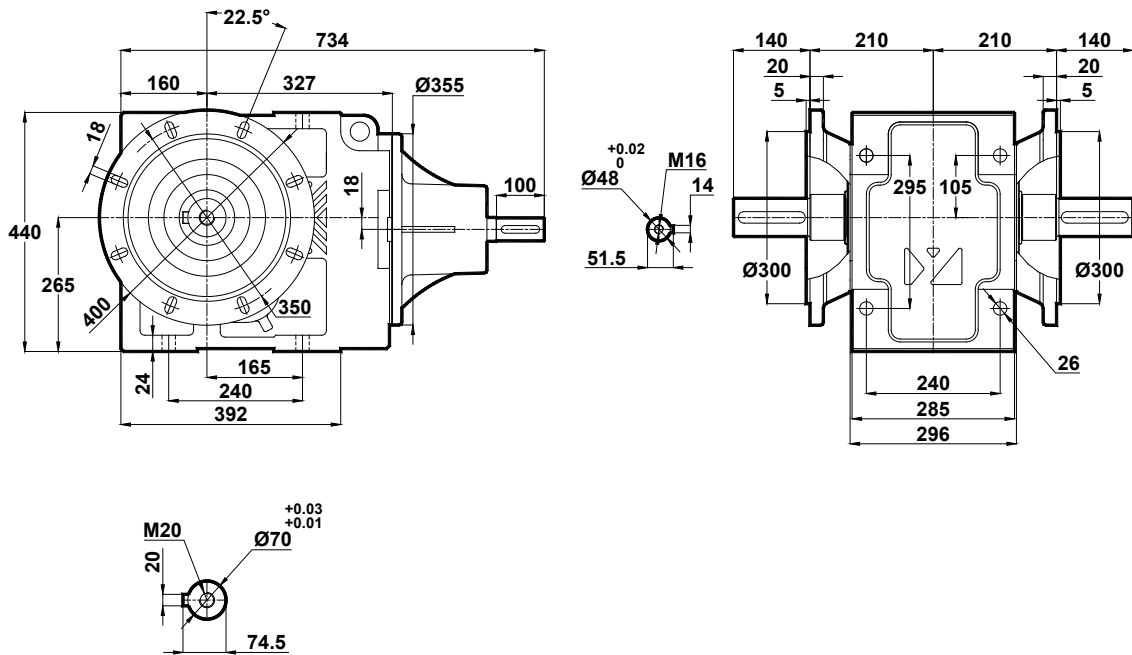



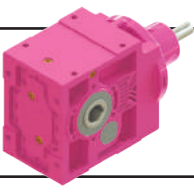

# Ölçü Sayfaları

## Dimension Pages

### Abmessungsseiten

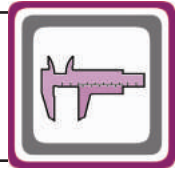

-Mil ucu çekirme deliği DIN 332 sayfa 2 / Tapped center hole to DIN 332, sheet 2 / Zentrierung mit gewinde DIN 332, Blatt 2

KT674.00

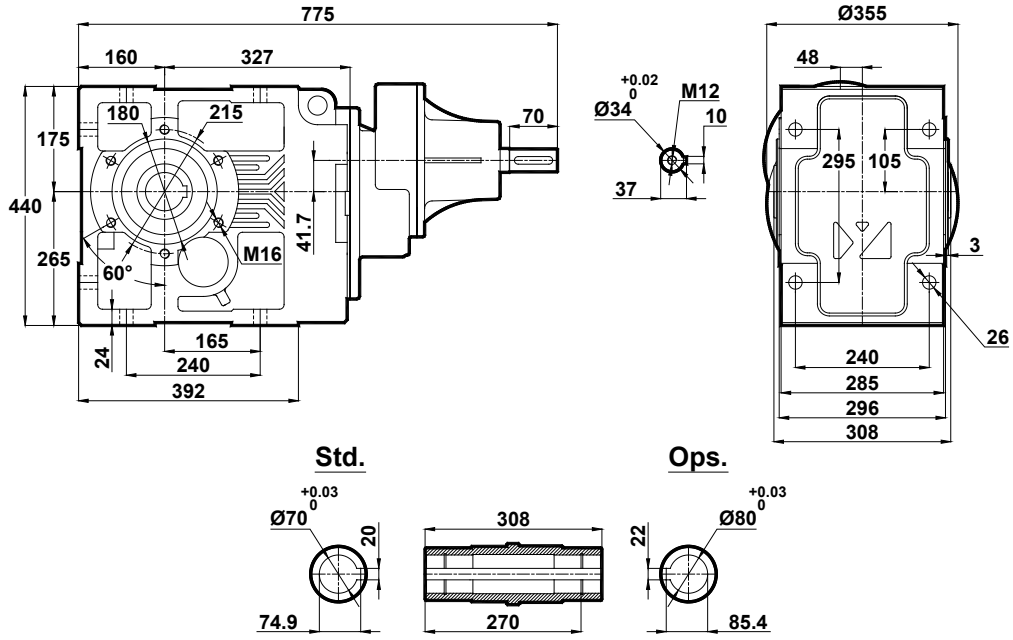

KT674.01

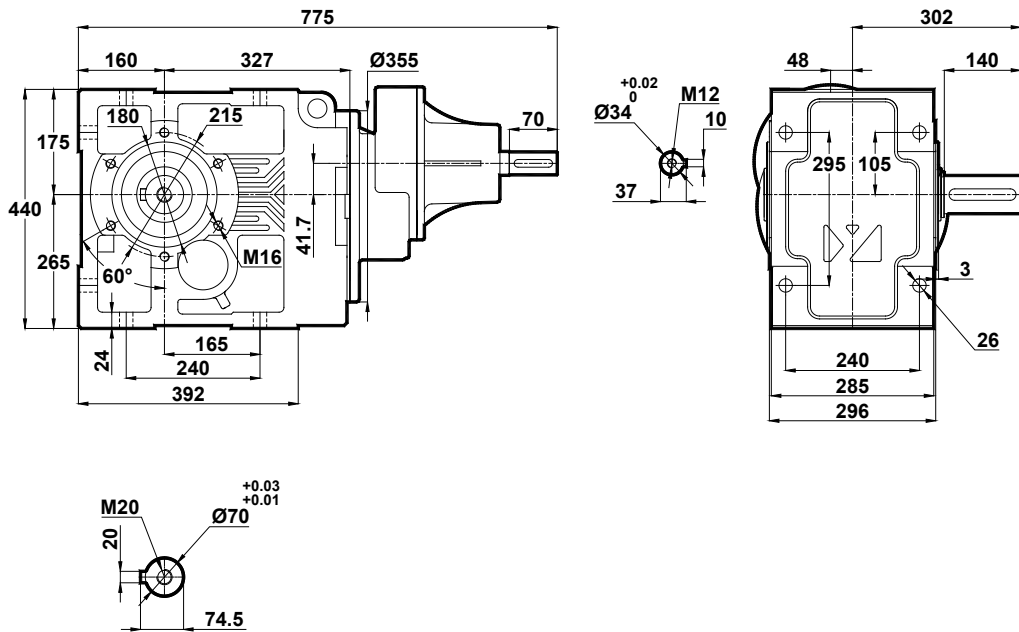

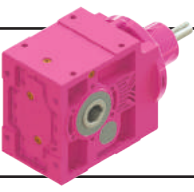

# Ölçü Sayfaları

## Dimension Pages

### Abmessungsseiten

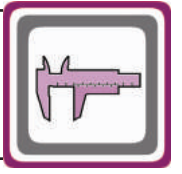

-Mil ucu çekirme deliği DIN 332 sayfa 2 / Tapped center hole to DIN 332, sheet 2 / Zentrierung mit gewinde DIN 332, Blatt 2

KT674.02

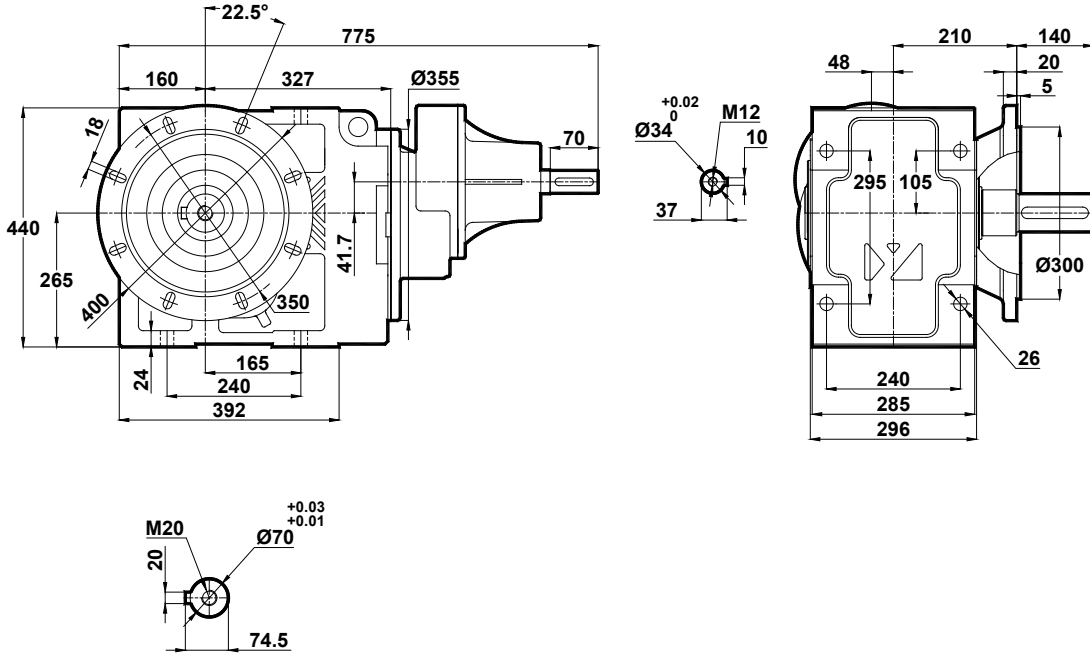

KT674.03

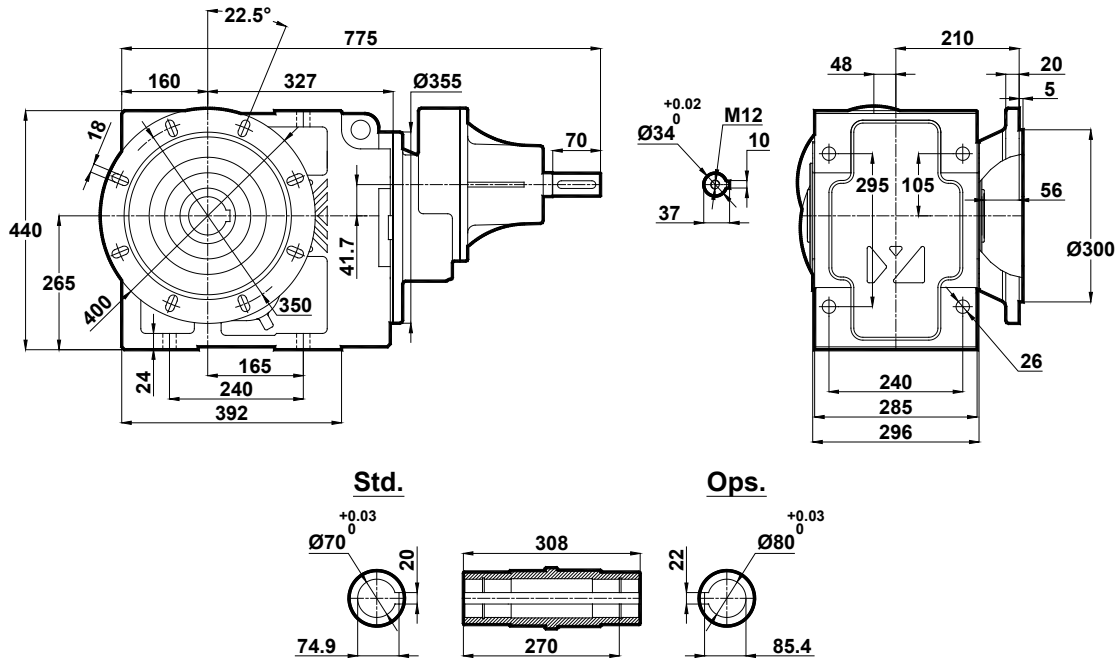

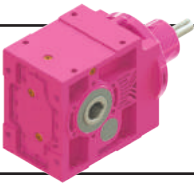

# Ölçü Sayfaları

## Dimension Pages

### Abmessungsseiten

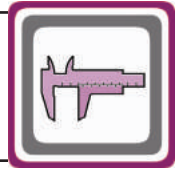

-Mil ucu çekirtme deliği DIN 332 sayfa 2 / Tapped center hole to DIN 332, sheet 2 / Zentrierung mit gewinde DIN 332, Blatt 2

KT674.04

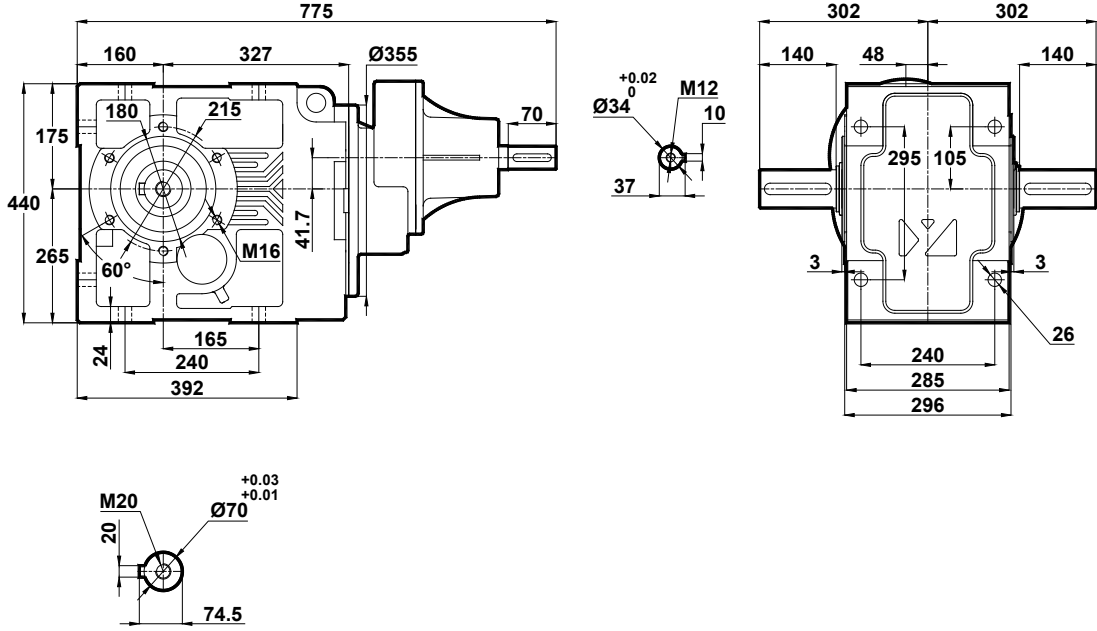

KT674.05

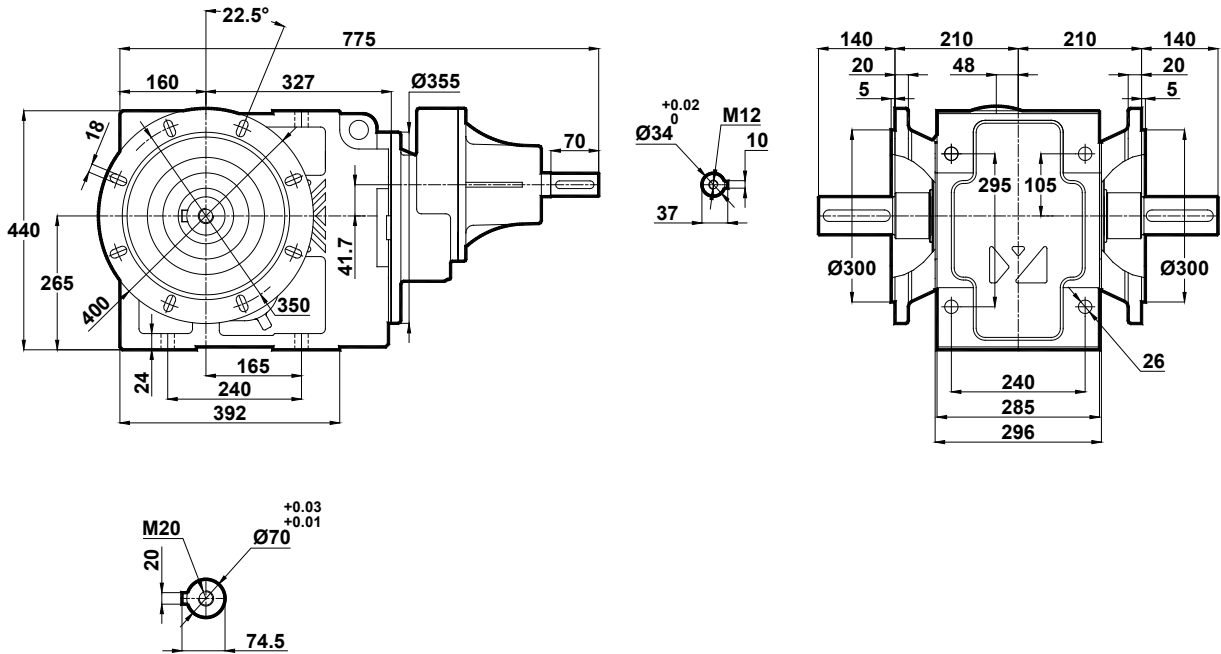

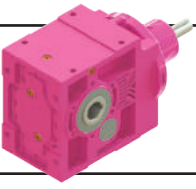

# Ölçü Sayfaları Dimension Pages Abmessungenseiten

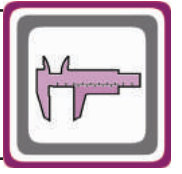

-Mil ucu çekirme deliği DIN 332 sayfa 2 / Tapped center hole to DIN 332, sheet 2 / Zentrierung mit gewinde DIN 332, Blatt 2

KT674.08

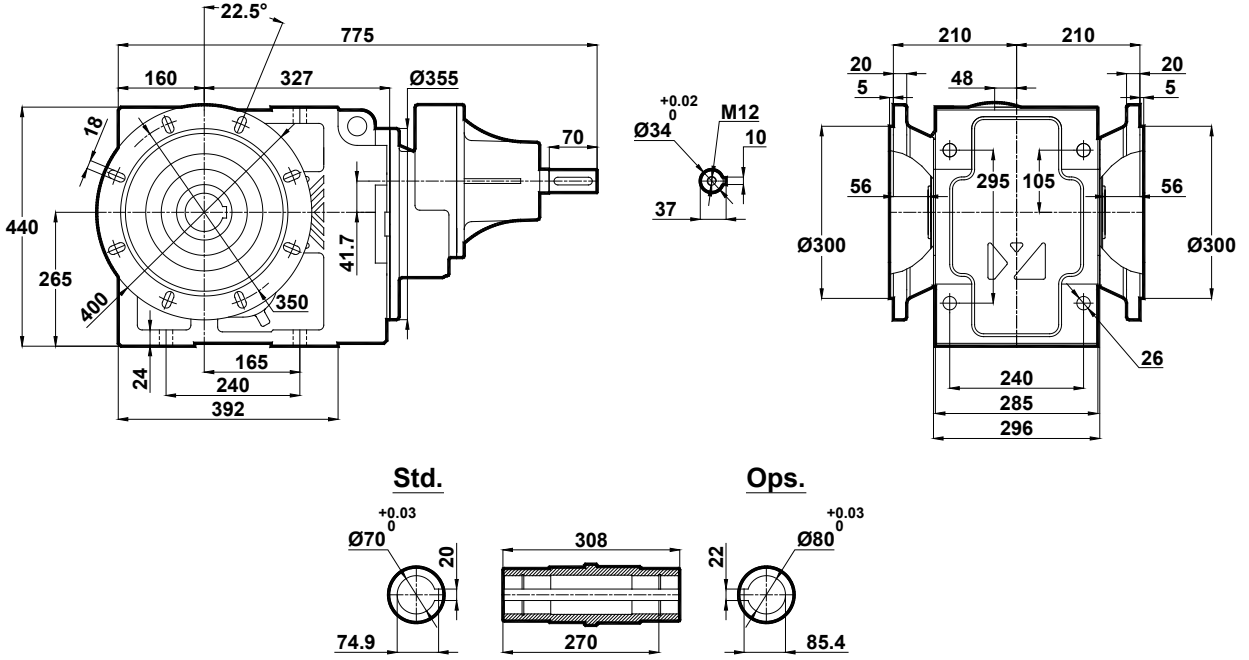

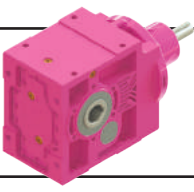

# Ölçü Sayfaları

## Dimension Pages

### Abmessungsseiten

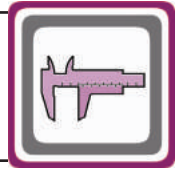

-Mil ucu çekirme deliği DIN 332 sayfa 2 / Tapped center hole to DIN 332, sheet 2 / Zentrierung mit gewinde DIN 332, Blatt 2

KT675.00  
KT676.00

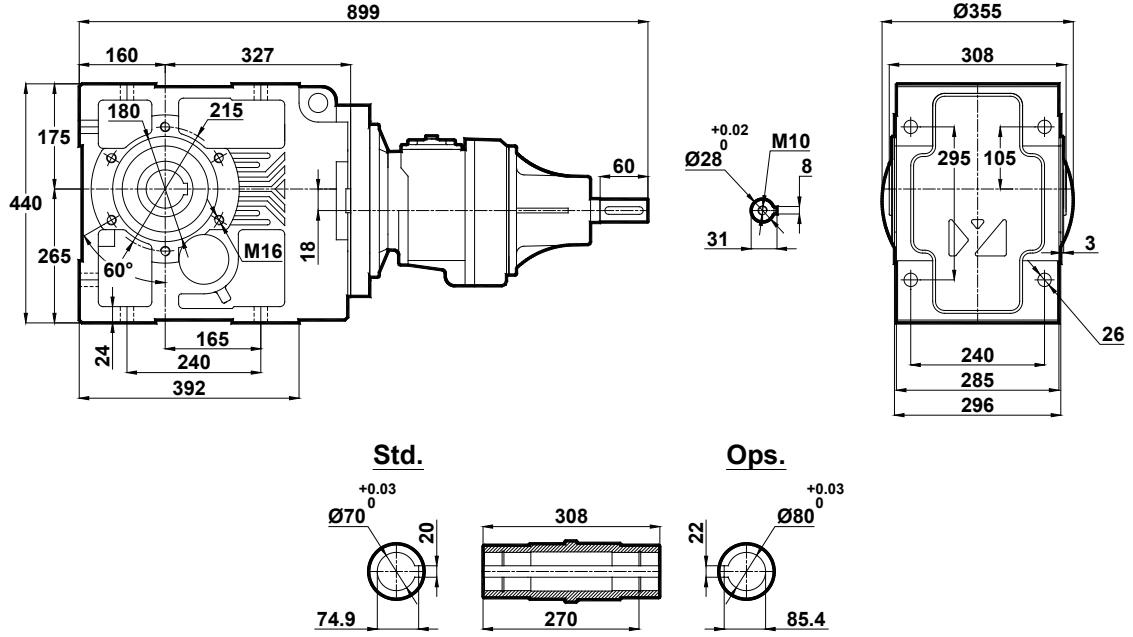

KT675.01  
KT676.01

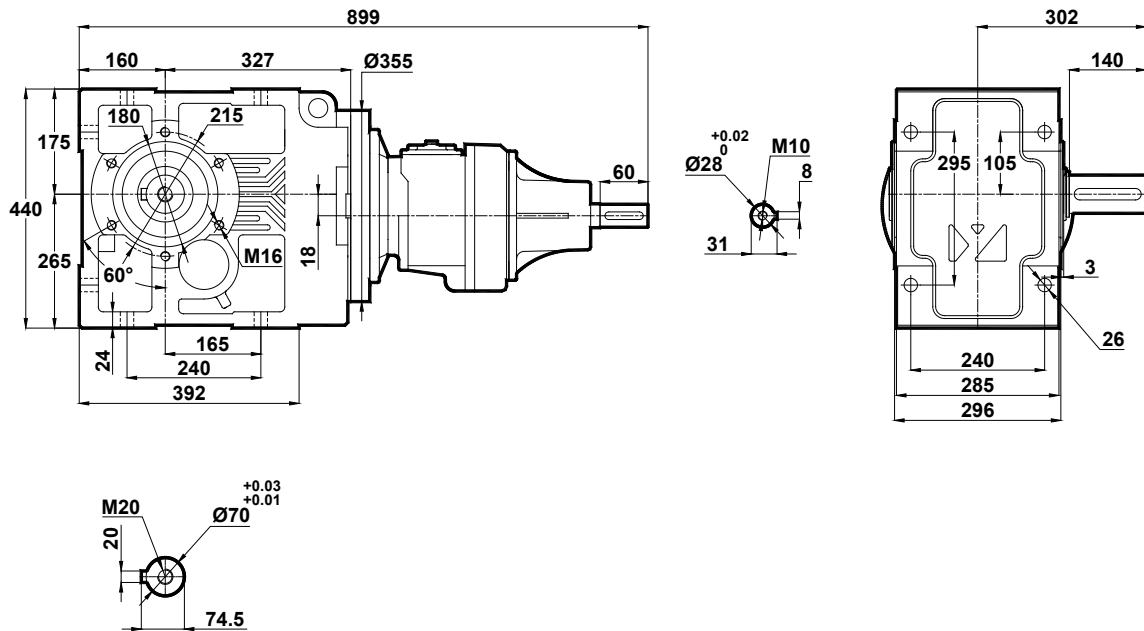

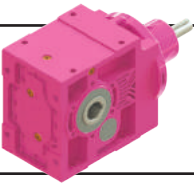

# Ölçü Sayfaları Dimension Pages Abmessungenseiten

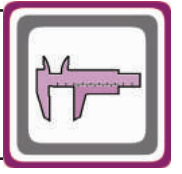

-Mil ucu çekirme deliği DIN 332 sayfa 2 / Tapped center hole to DIN 332, sheet 2 / Zentrierung mit gewinde DIN 332, Blatt 2

KT675.02  
KT676.02

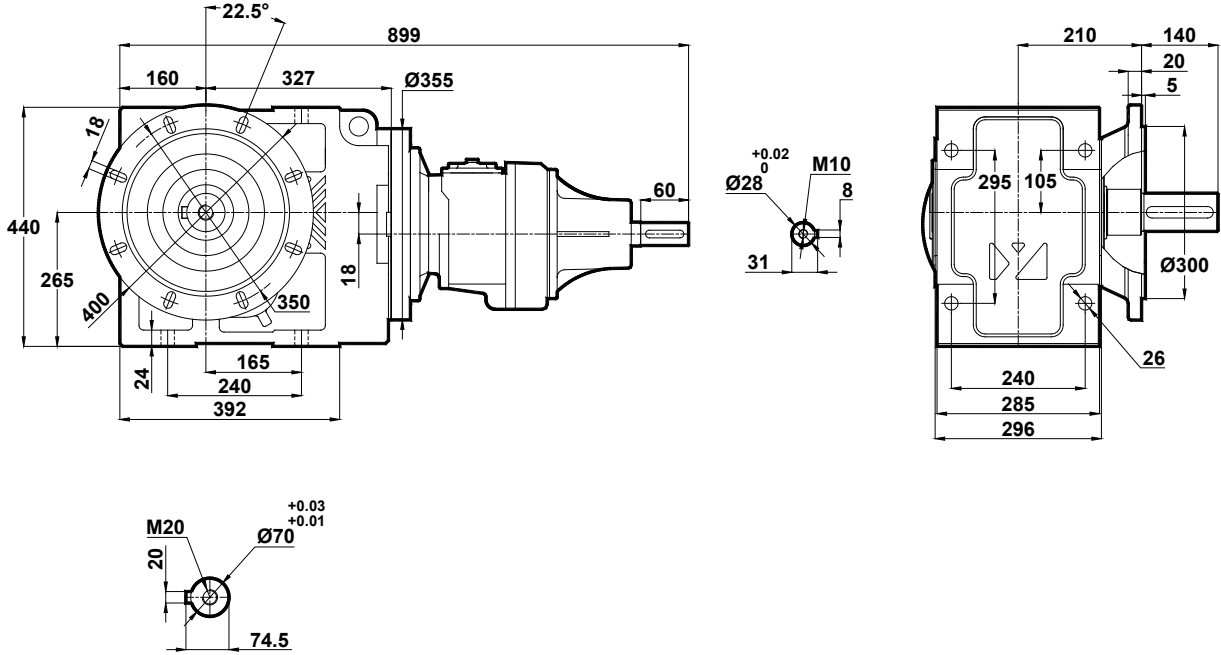

KT675.03  
KT676.03

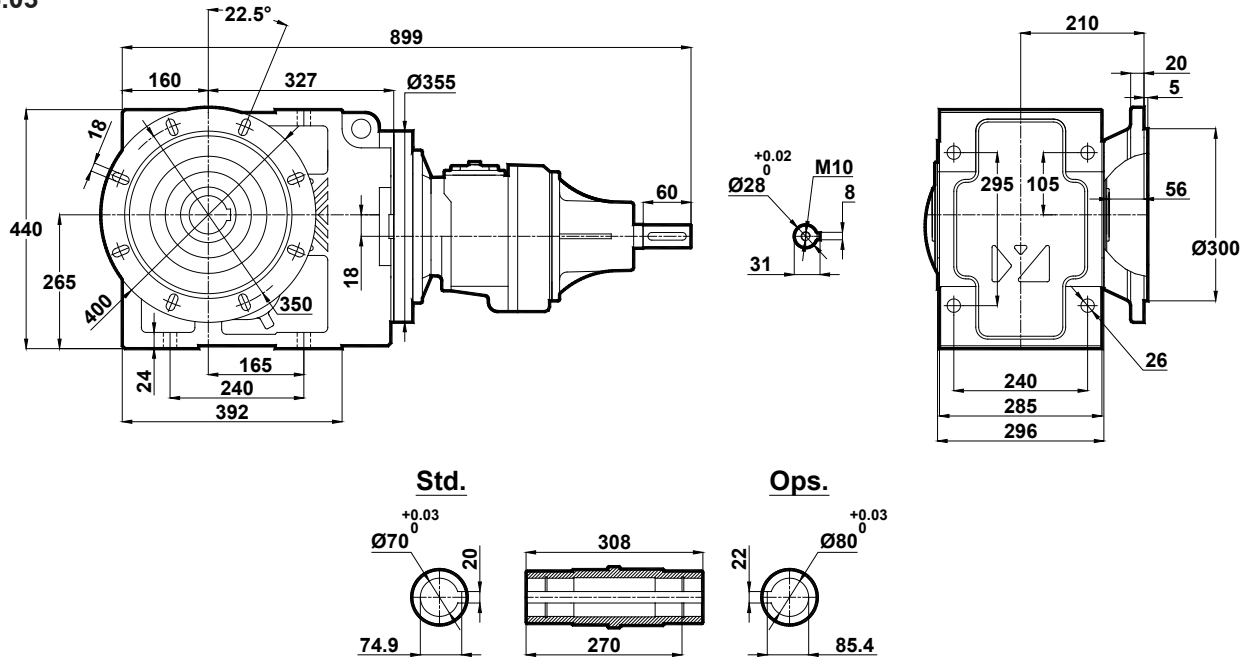

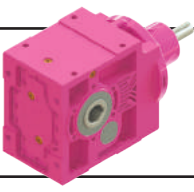

# Ölçü Sayfaları

## Dimension Pages

### Abmessungsseiten

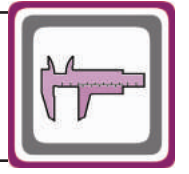

-Mil ucu çekirme deliği DIN 332 sayfa 2 / Tapped center hole to DIN 332, sheet 2 / Zentrierung mit gewinde DIN 332, Blatt 2

KT675.04  
KT676.04

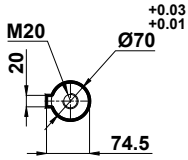
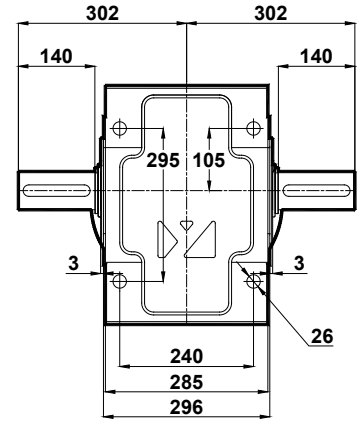
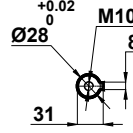
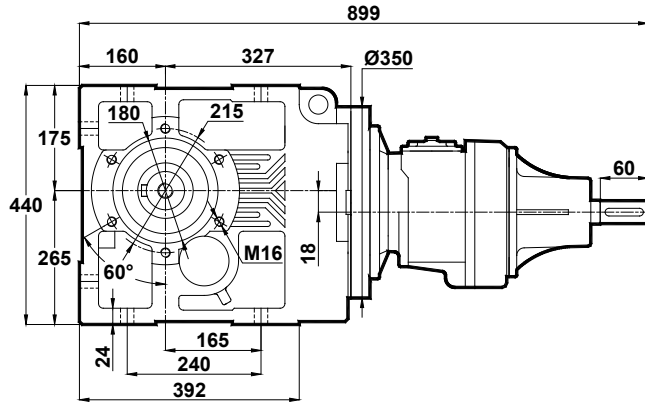

KT675.05  
KT676.05

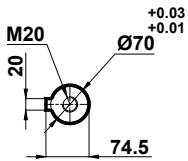
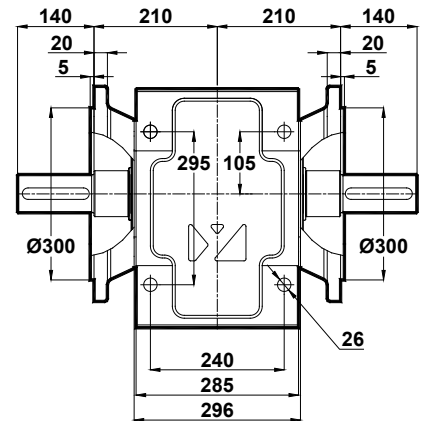
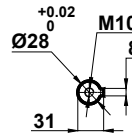
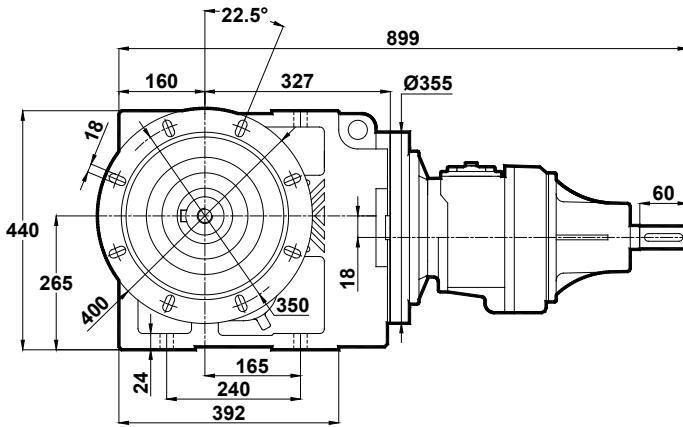

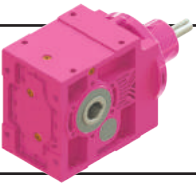

# Ölçü Sayfaları

## Dimension Pages

### Abmessungenseiten

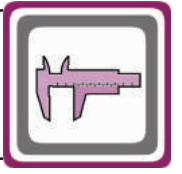

-Mil ucu çektirme deliği DIN 332 sayfa 2 / Tapped center hole to DIN 332, sheet 2 / Zentrierung mit gewinde DIN 332, Blatt 2

KT675.08  
KT676.08

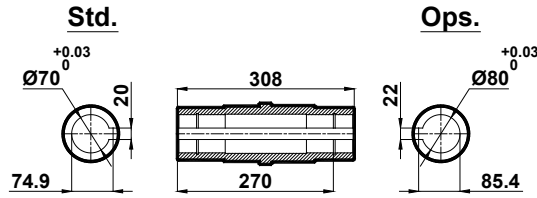
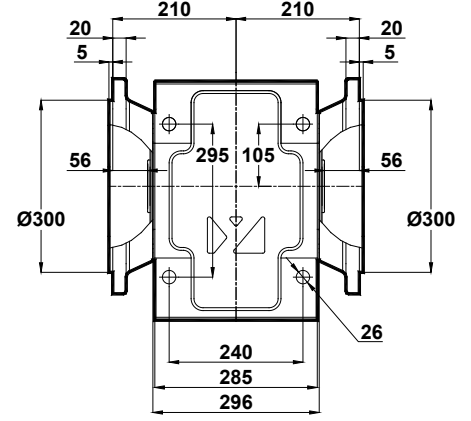
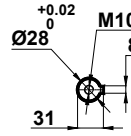
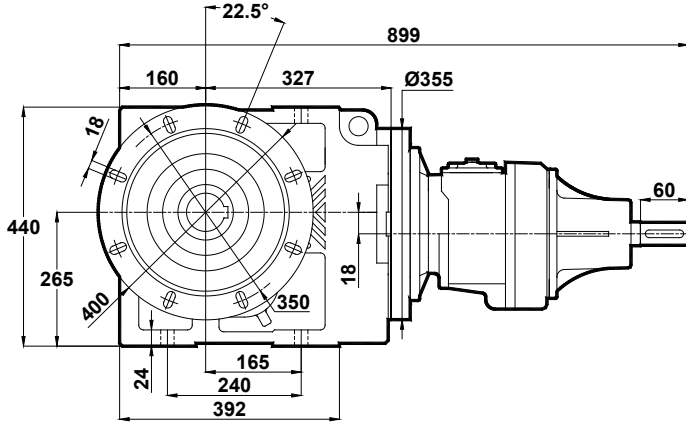

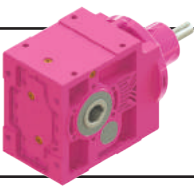

# Ölçü Sayfaları

## Dimension Pages

### Abmessungsseiten

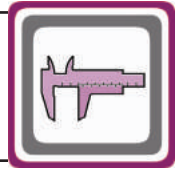

-Mil ucu çektirme deliği DIN 332 sayfa 2 / Tapped center hole to DIN 332, sheet 2 / Zentrierung mit gewinde DIN 332, Blatt 2

KT773.00

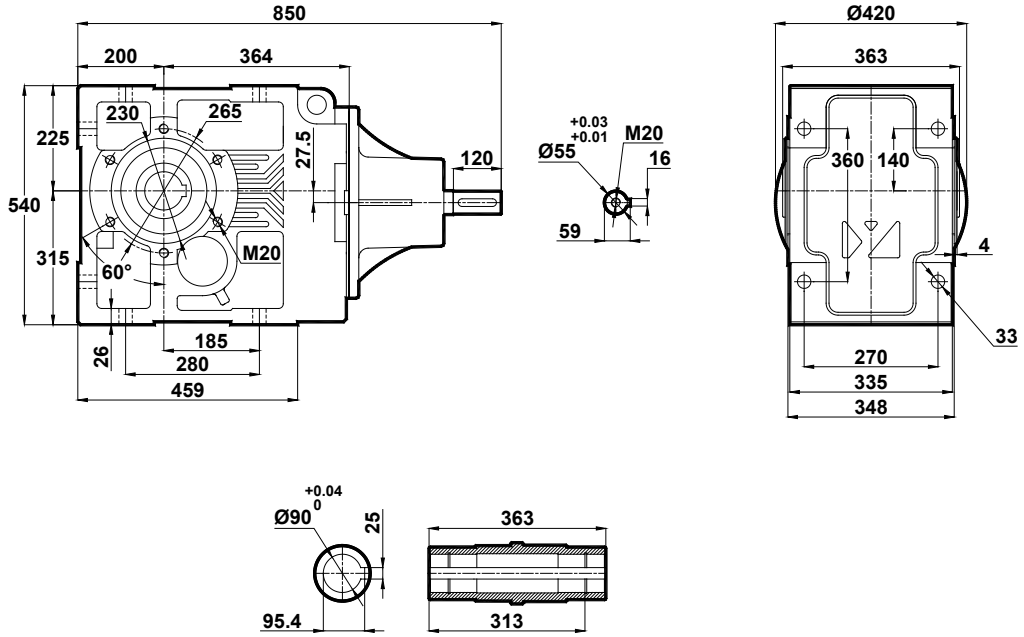

KT773.01

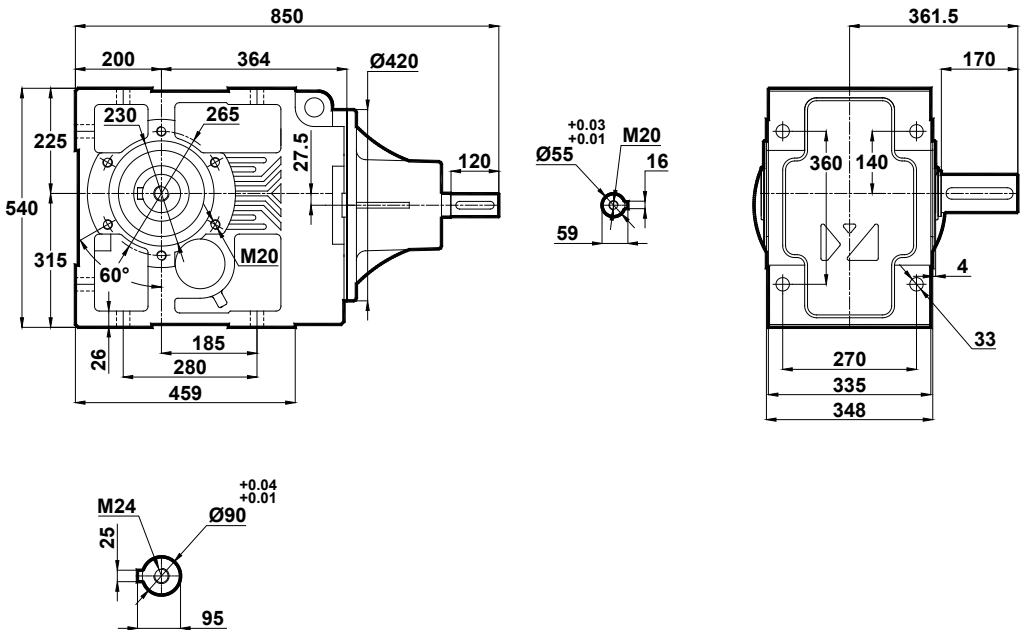

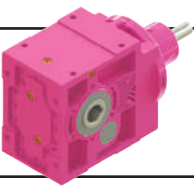

# Ölçü Sayfaları Dimension Pages Abmessungenseiten

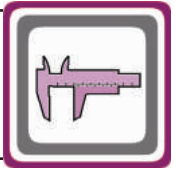

-Mil ucu çektirme deliği DIN 332 sayfa 2 / Tapped center hole to DIN 332, sheet 2 / Zentrierung mit gewinde DIN 332, Blatt 2

KT773.02

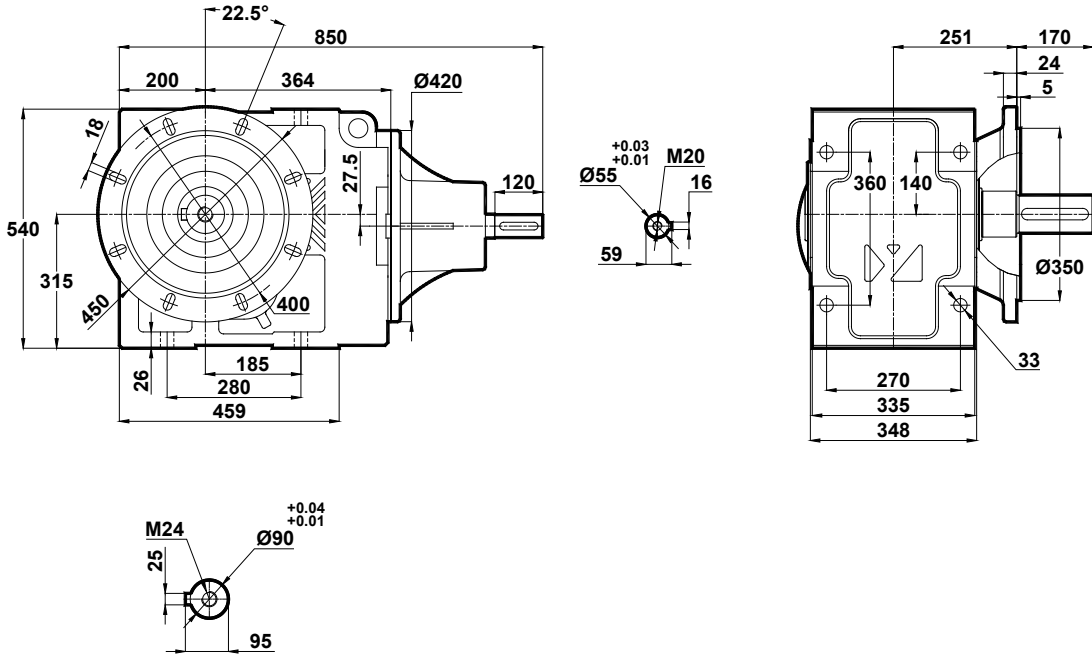

KT773.03

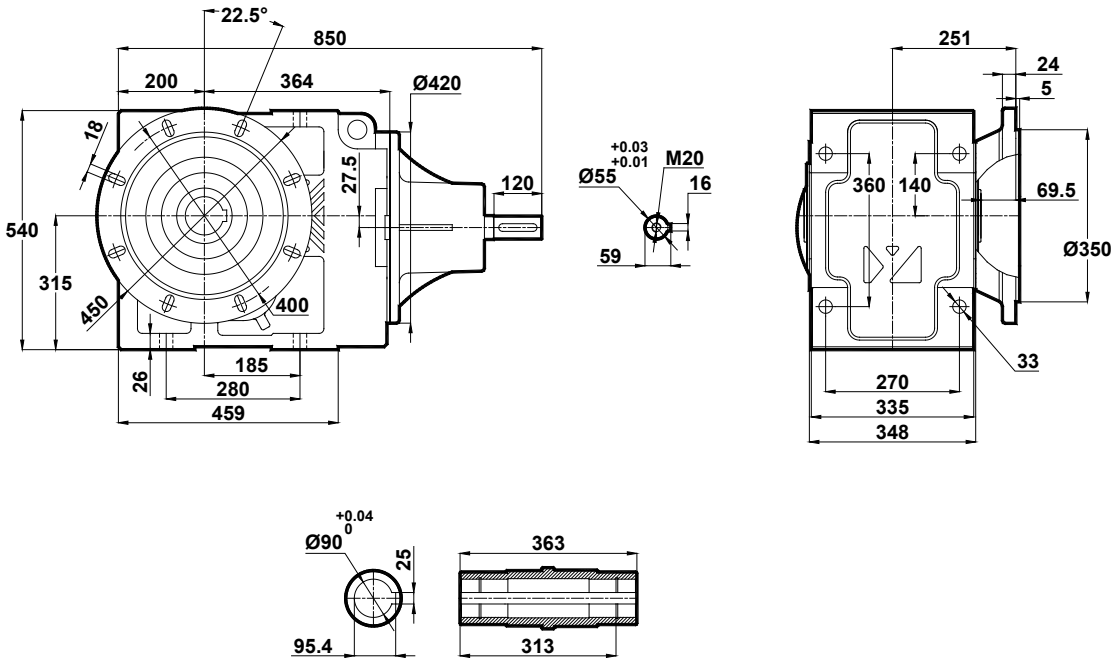

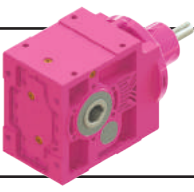

# Ölçü Sayfaları Dimension Pages Abmessungsseiten

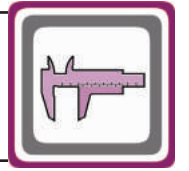

-Mil ucu çekirme deliği DIN 332 sayfa 2 / Tapped center hole to DIN 332, sheet 2 / Zentrierung mit gewinde DIN 332, Blatt 2

KT773.04

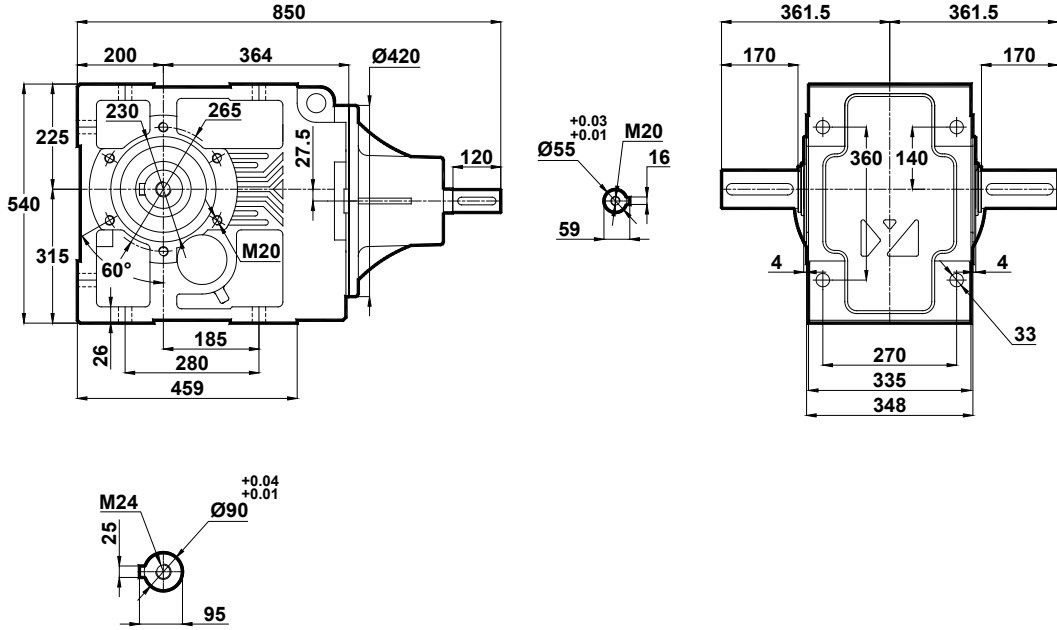

KT773.05

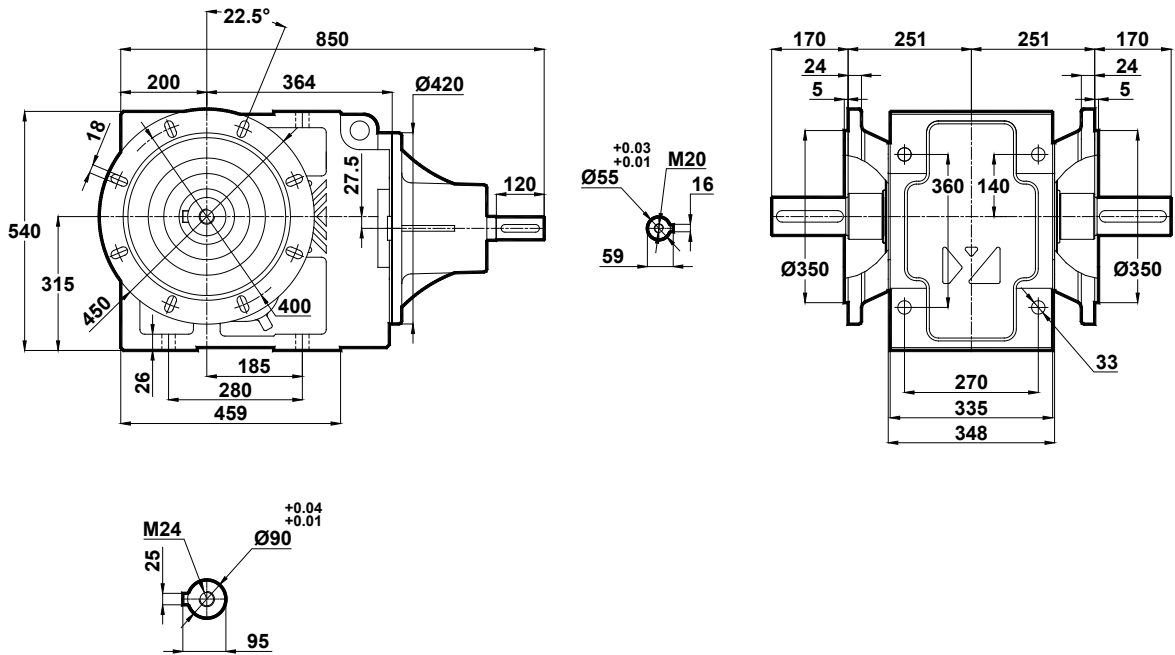

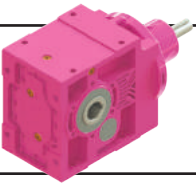

# Ölçü Sayfaları Dimension Pages Abmessungenseiten

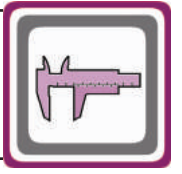

-Mil ucu çekirme deliği DIN 332 sayfa 2 / Tapped center hole to DIN 332, sheet 2 / Zentrierung mit gewinde DIN 332, Blatt 2

KT773.08

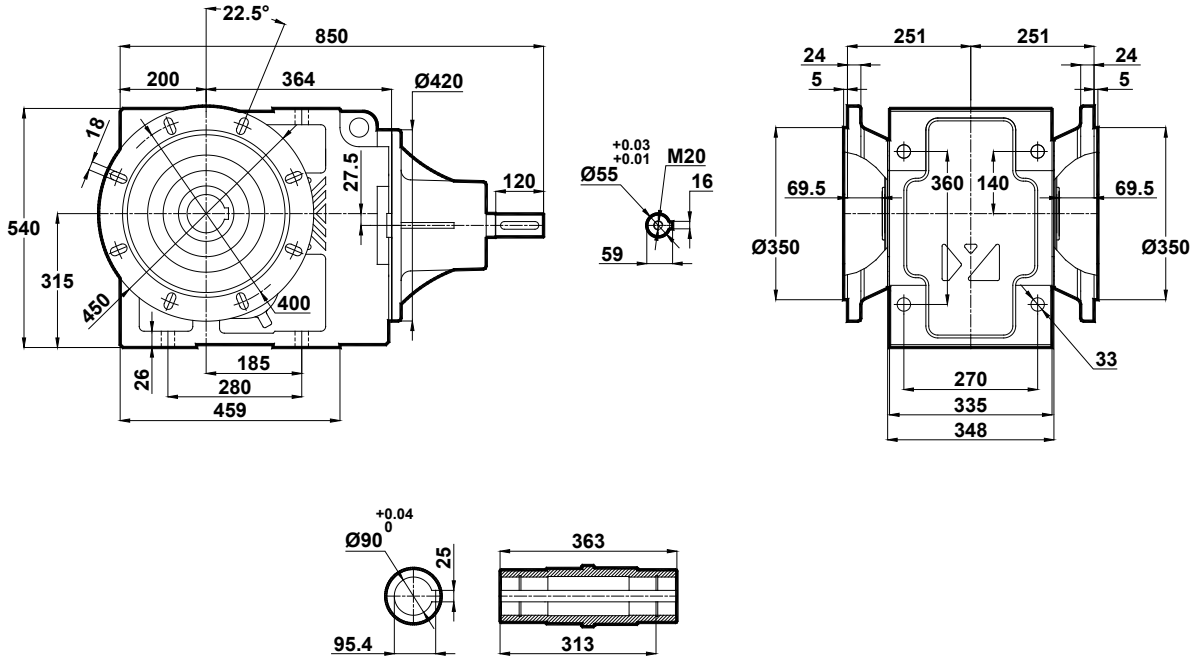

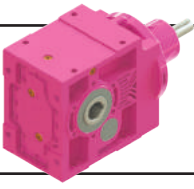

# Ölçü Sayfaları

## Dimension Pages

### Abmessungsseiten

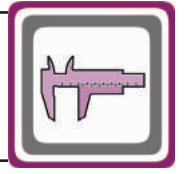

-Mil ucu çekirme deliği DIN 332 sayfa 2 / Tapped center hole to DIN 332, sheet 2 / Zentrierung mit gewinde DIN 332, Blatt 2

KT774.00

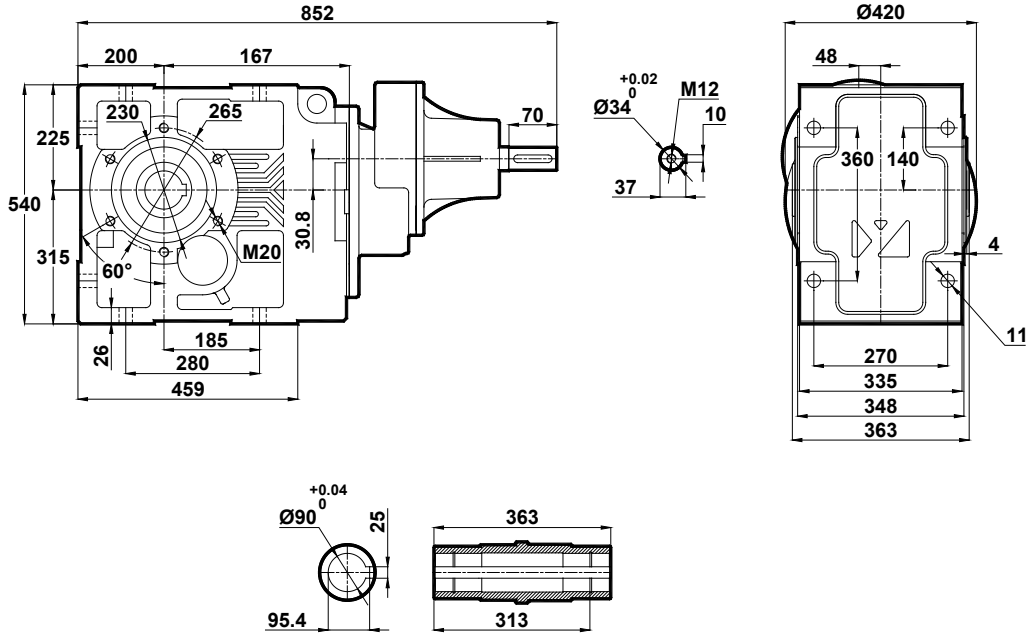

KT774.01

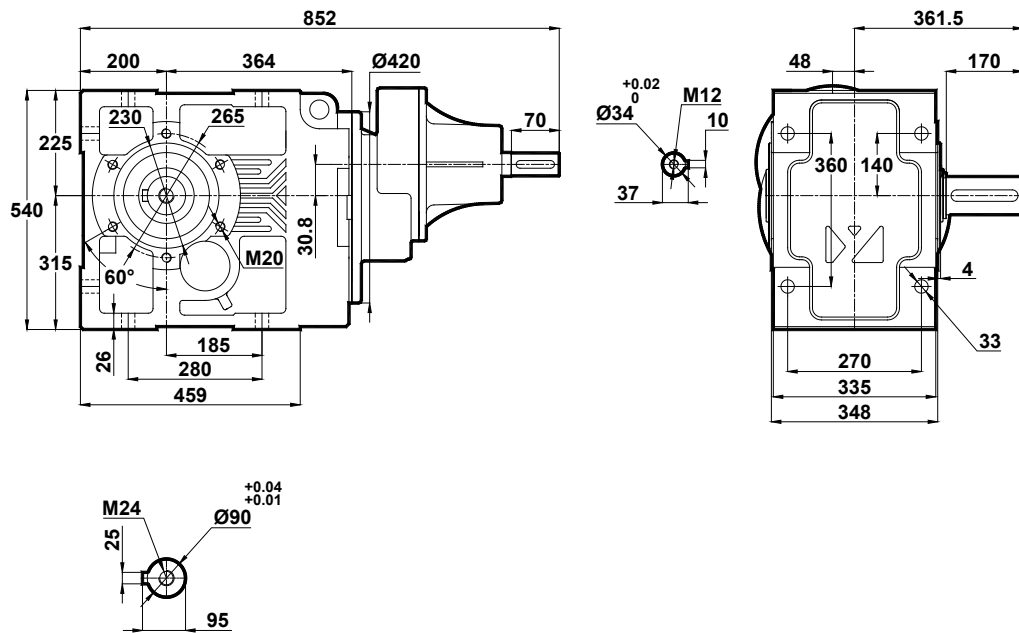

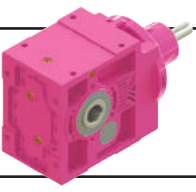

# Ölçü Sayfaları

## Dimension Pages

### Abmessungsseiten

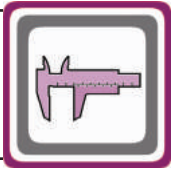

-Mil ucu çektirme deliği DIN 332 sayfa 2 / Tapped center hole to DIN 332, sheet 2 / Zentrierung mit gewinde DIN 332, Blatt 2

KT774.02

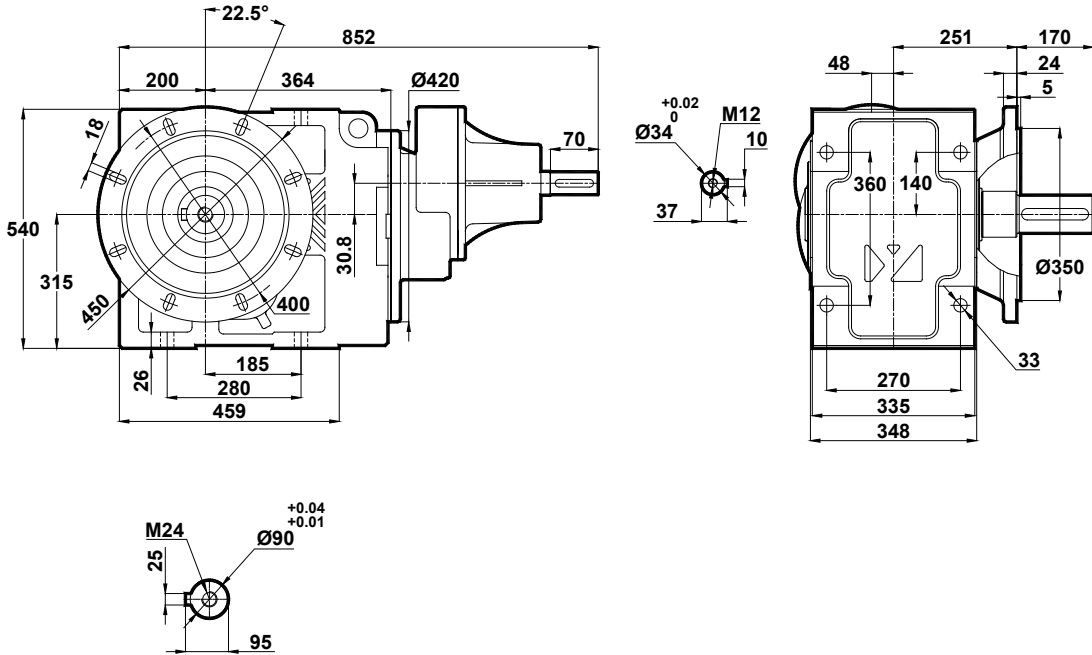

KT774.03

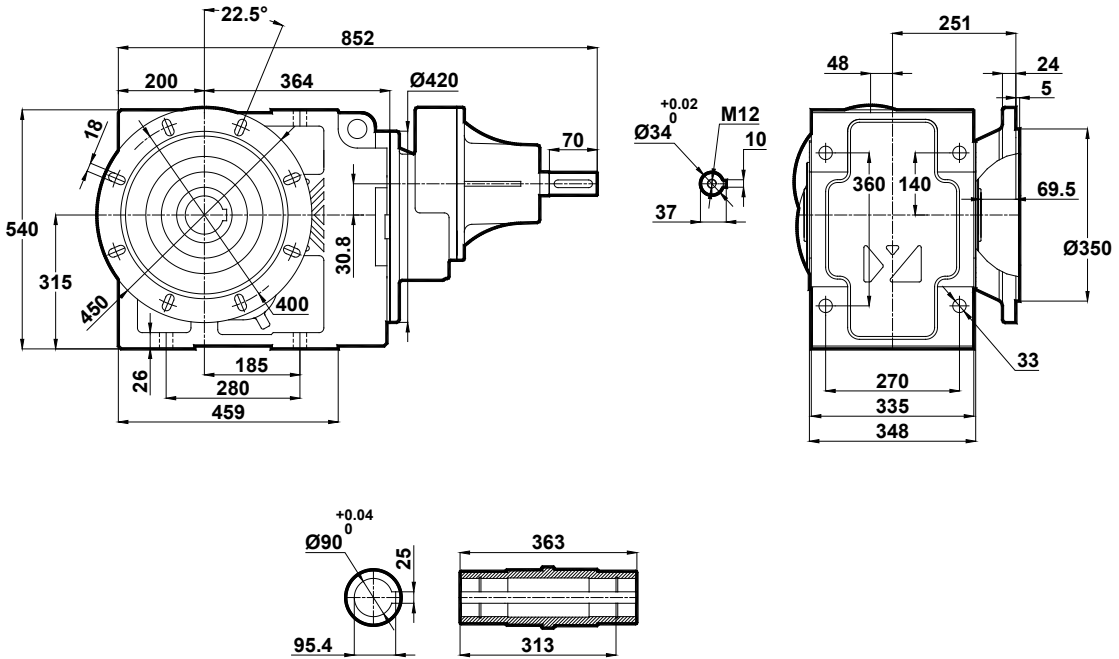

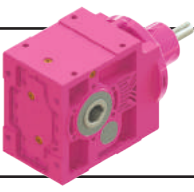

# Ölçü Sayfaları

## Dimension Pages

### Abmessungsseiten

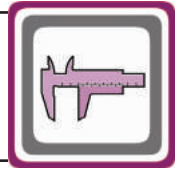

-Mil ucu çekirme deliği DIN 332 sayfa 2 / Tapped center hole to DIN 332, sheet 2 / Zentrierung mit gewinde DIN 332, Blatt 2

KT774.04

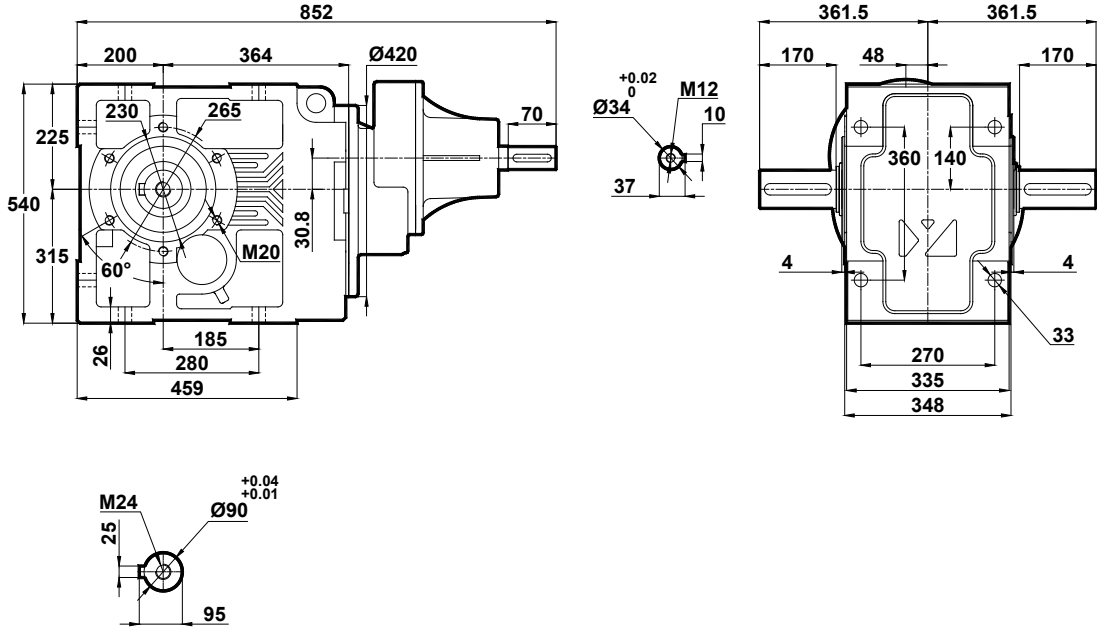

KT774.05

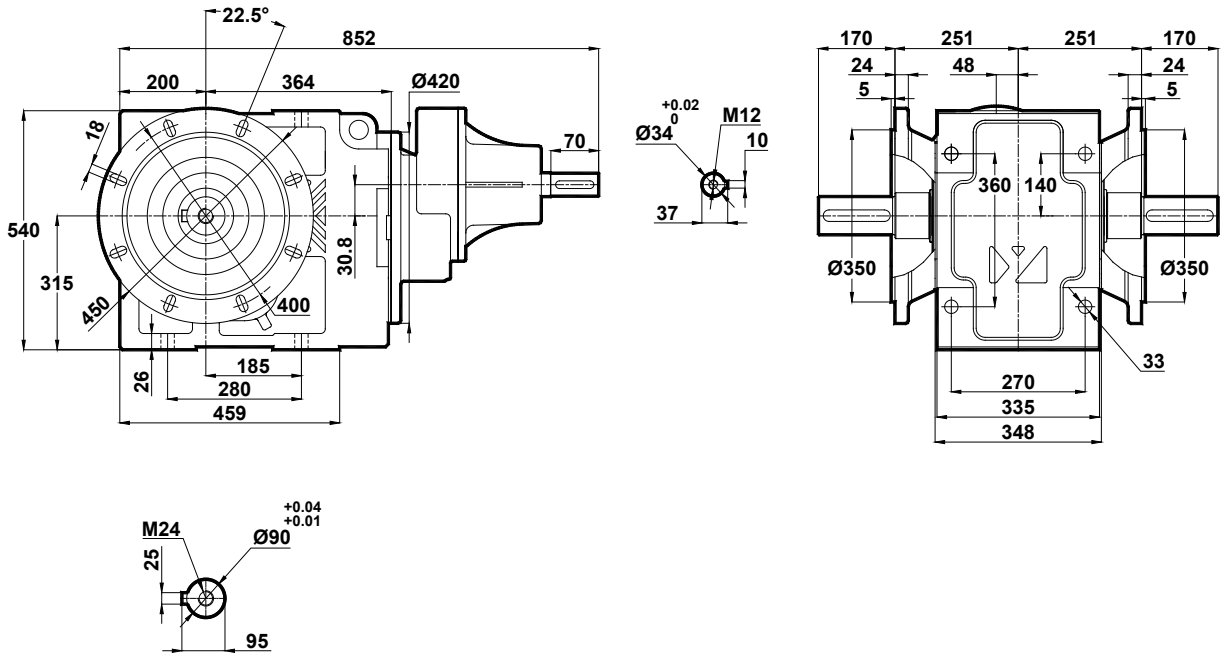

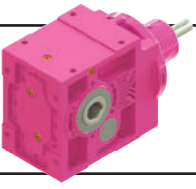

# Ölçü Sayfaları Dimension Pages Abmessungsseiten

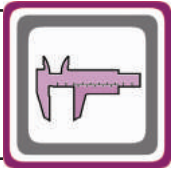

-Mil ucu çekirme deliği DIN 332 sayfa 2 / Tapped center hole to DIN 332, sheet 2 / Zentrierung mit gewinde DIN 332, Blatt 2

KT774.08

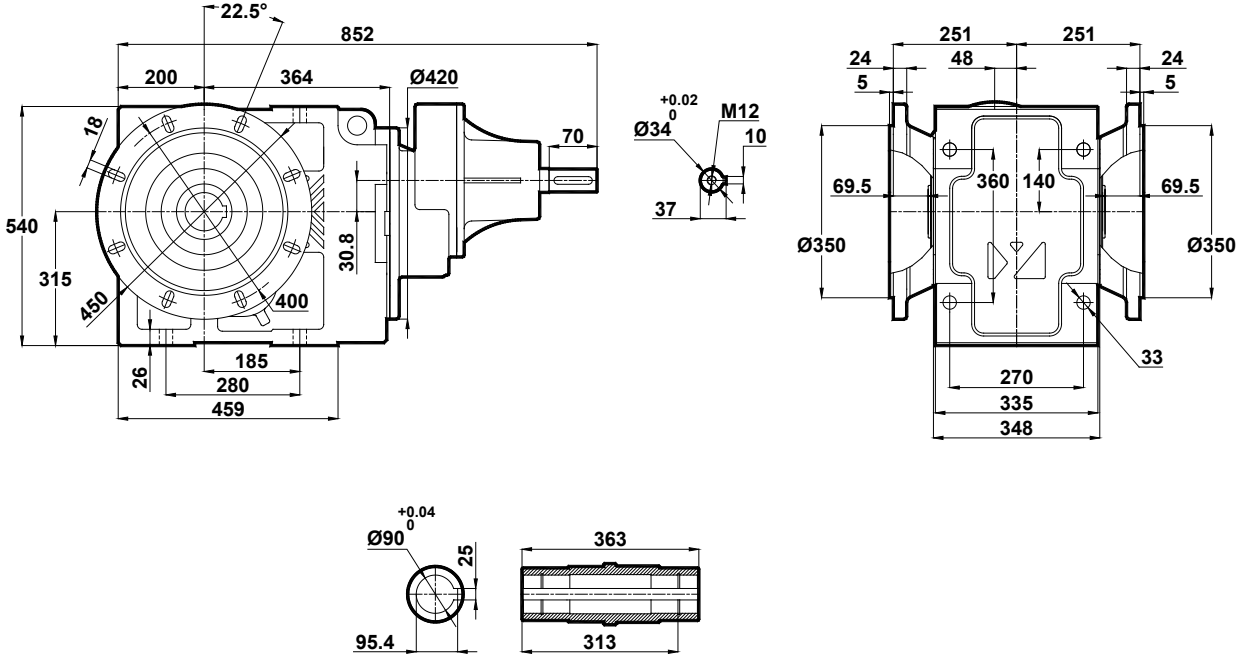

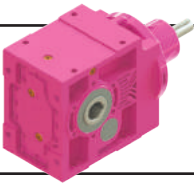

# Ölçü Sayfaları

## Dimension Pages

### Abmessungsseiten

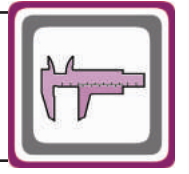

-Mil ucu çekirme deliği DIN 332 sayfa 2 / Tapped center hole to DIN 332, sheet 2 / Zentrierung mit gewinde DIN 332, Blatt 2

KT775.00  
KT776.00

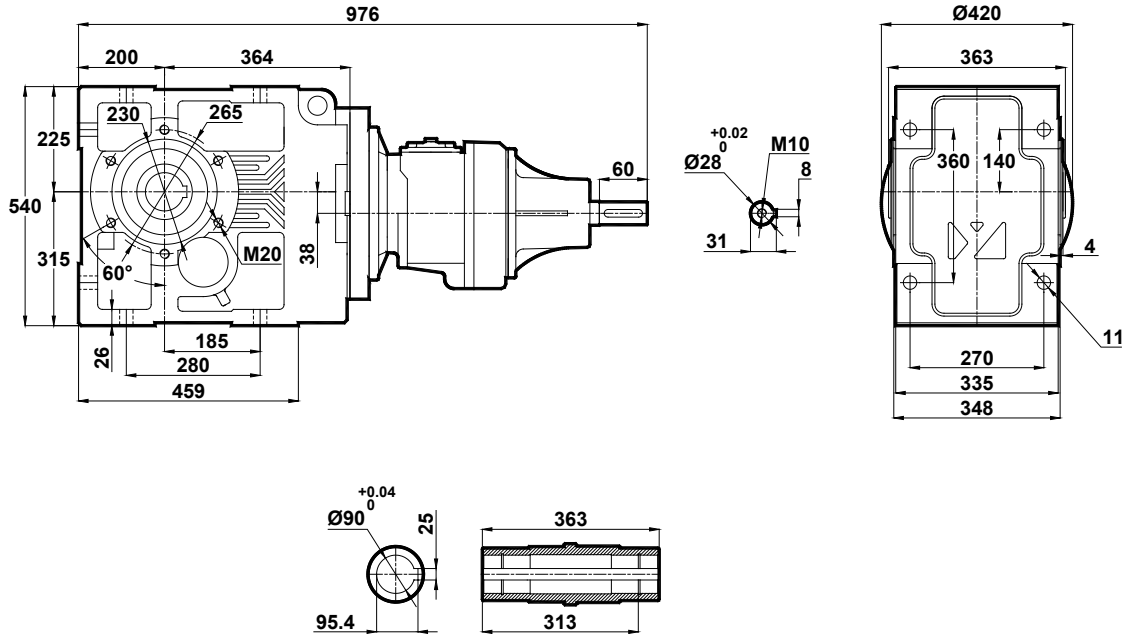

KT775.01  
KT776.01

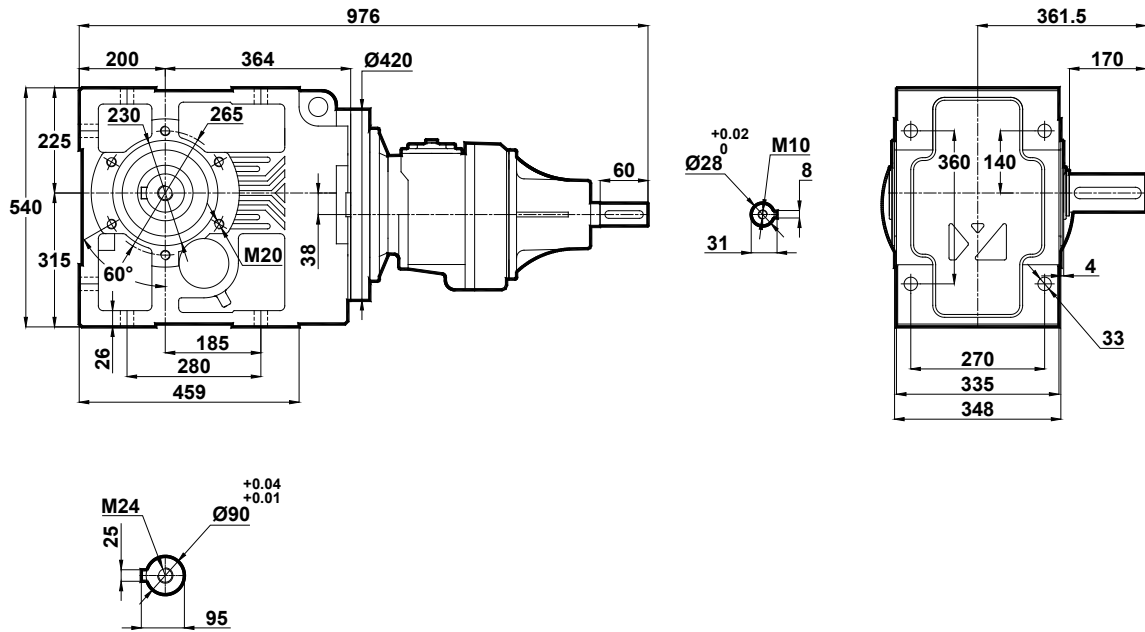

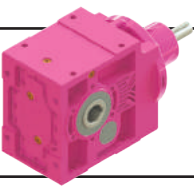

# Ölçü Sayfaları Dimension Pages Abmessungenseiten

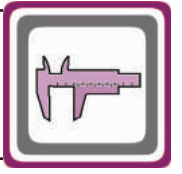

-Mil ucu çekirme deliği DIN 332 sayfa 2 / Tapped center hole to DIN 332, sheet 2 / Zentrierung mit gewinde DIN 332, Blatt 2

KT775.02  
KT776.02

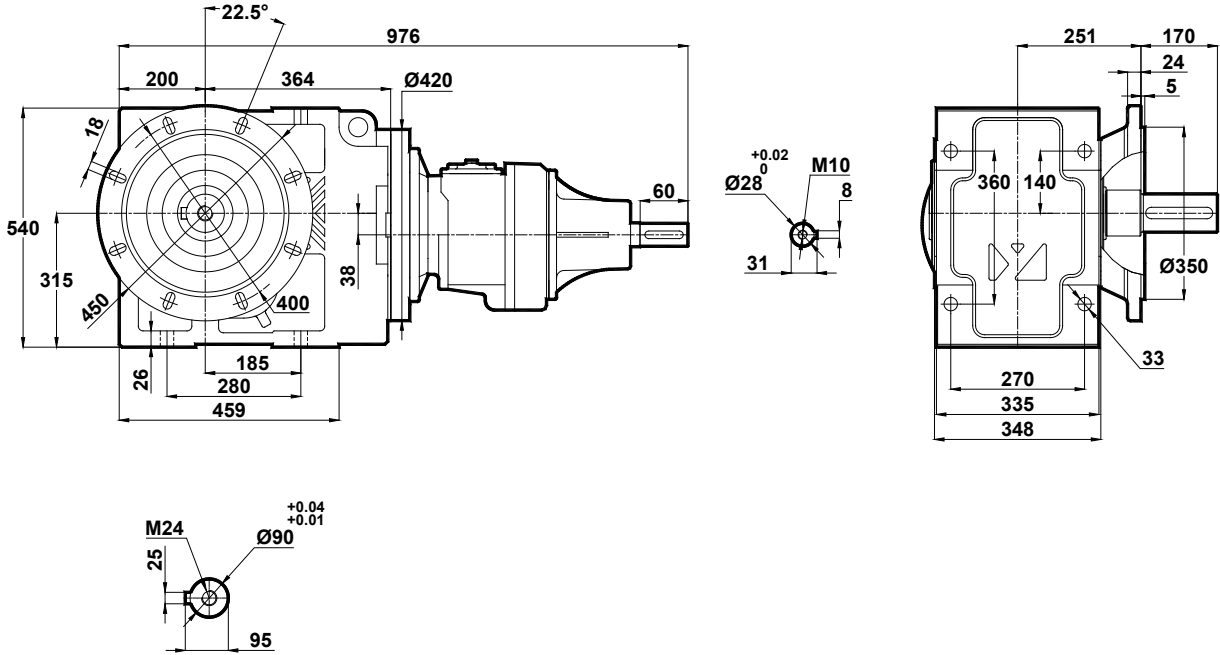

KT775.03  
KT776.03

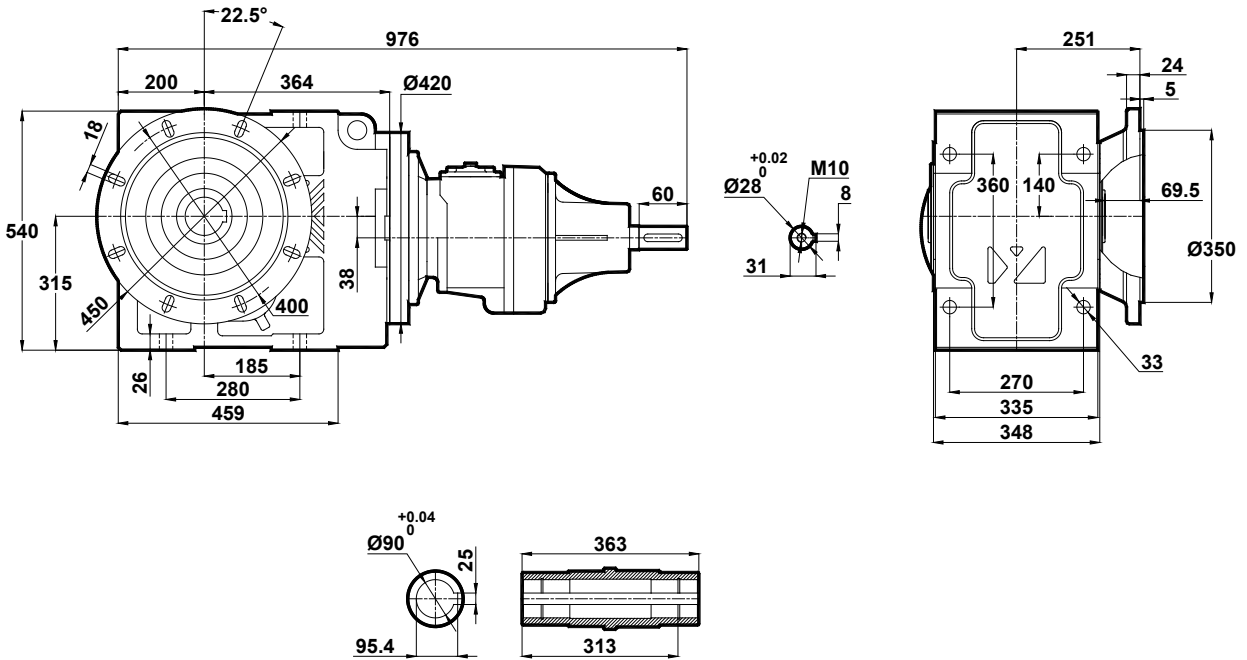

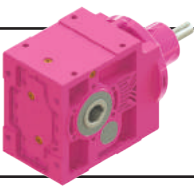

# Ölçü Sayfaları

## Dimension Pages

### Abmessungsseiten

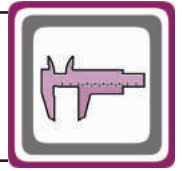

-Mil ucu çekirme deliği DIN 332 sayfa 2 / Tapped center hole to DIN 332, sheet 2 / Zentrierung mit gewinde DIN 332, Blatt 2

KT775.04  
KT776.04

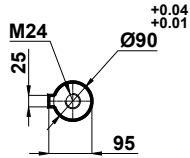
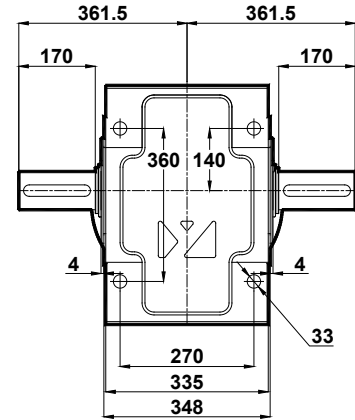
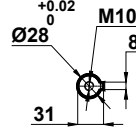
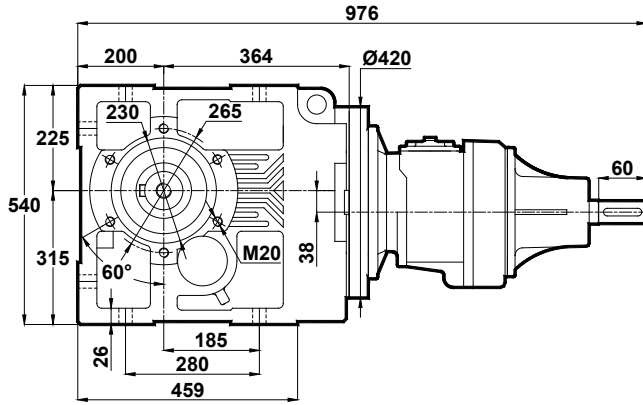

KT775.05  
KT776.05

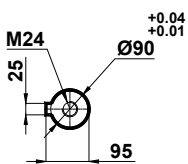
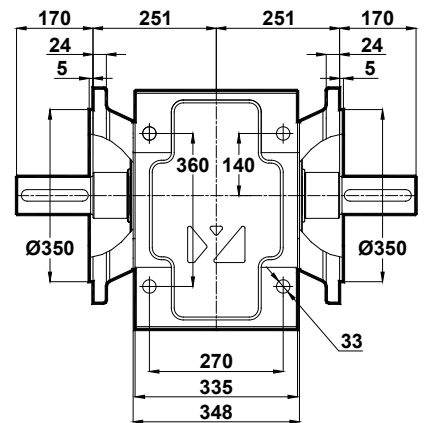
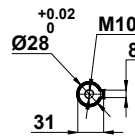
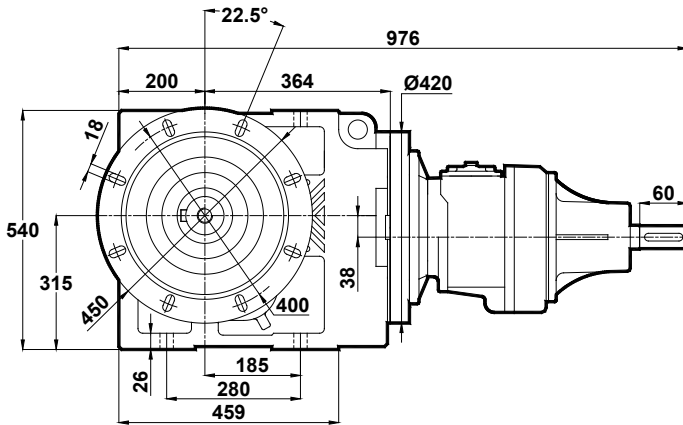

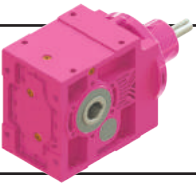

# Ölçü Sayfaları Dimension Pages Abmessungenseiten

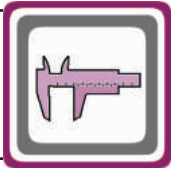

-Mil ucu çekirme deliği DIN 332 sayfa 2 / Tapped center hole to DIN 332, sheet 2 / Zentrierung mit gewinde DIN 332, Blatt 2

KT775.08  
KT776.08

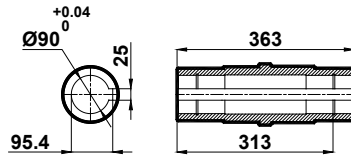
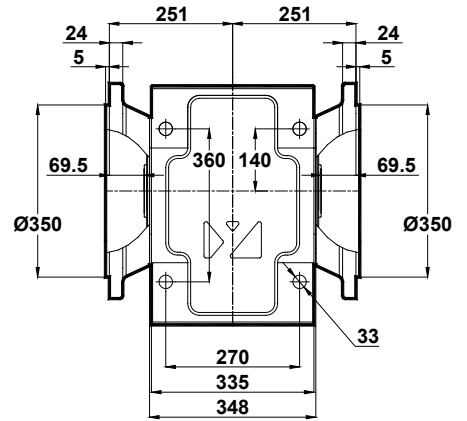
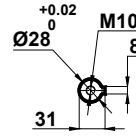
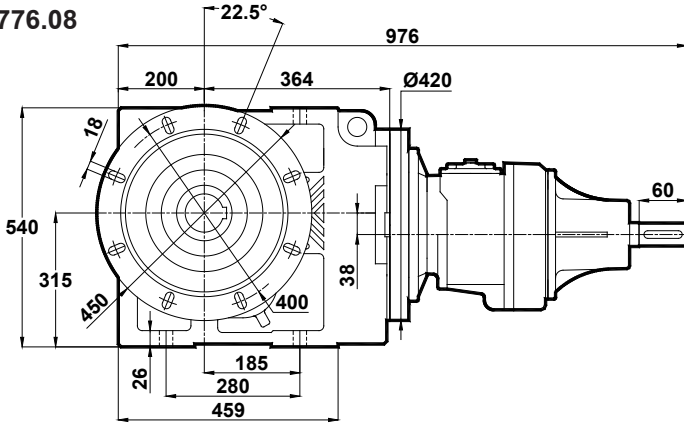

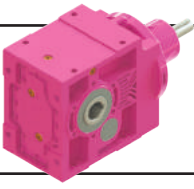

# Ölçü Sayfaları

## Dimension Pages

### Abmessungsseiten

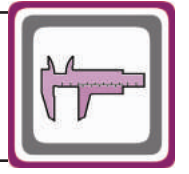

-Mil ucu çekirme deliği DIN 332 sayfa 2 / Tapped center hole to DIN 332, sheet 2 / Zentrierung mit gewinde DIN 332, Blatt 2

KT873.00

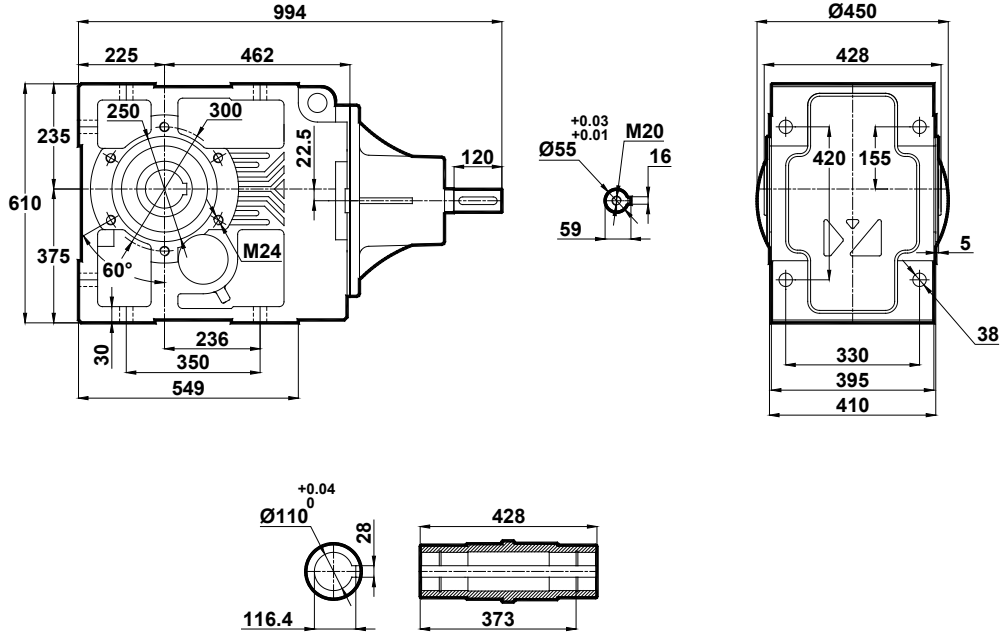

KT873.01

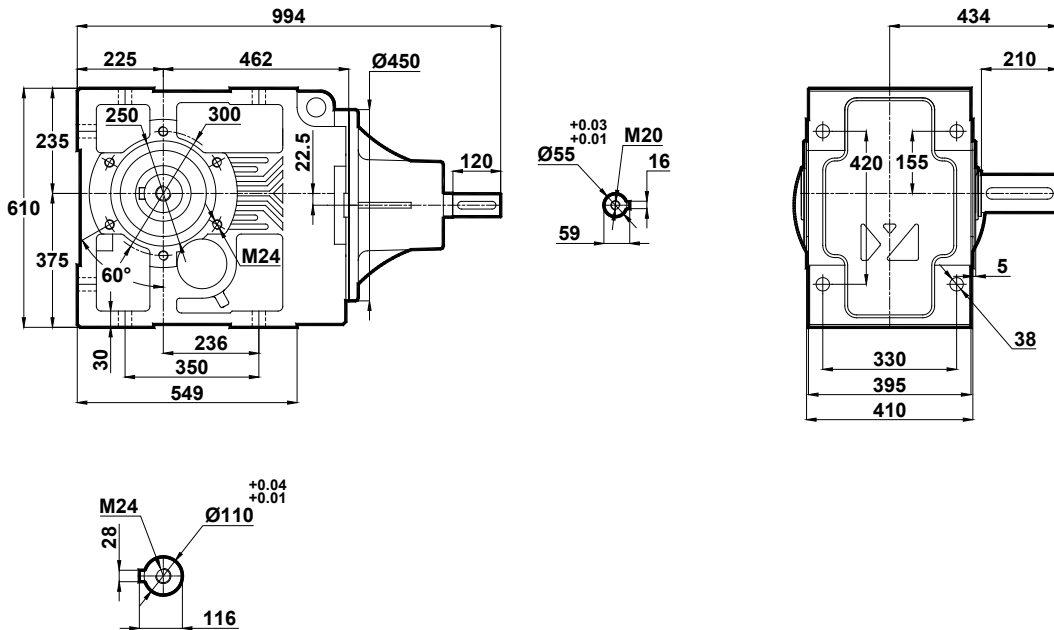

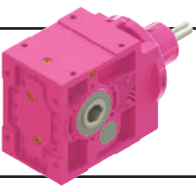

# Ölçü Sayfaları Dimension Pages Abmessungenseiten

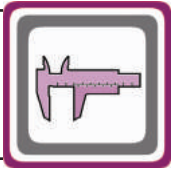

-Mil ucu çekirme deliği DIN 332 sayfa 2 / Tapped center hole to DIN 332, sheet 2 / Zentrierung mit gewinde DIN 332, Blatt 2

KT873.02

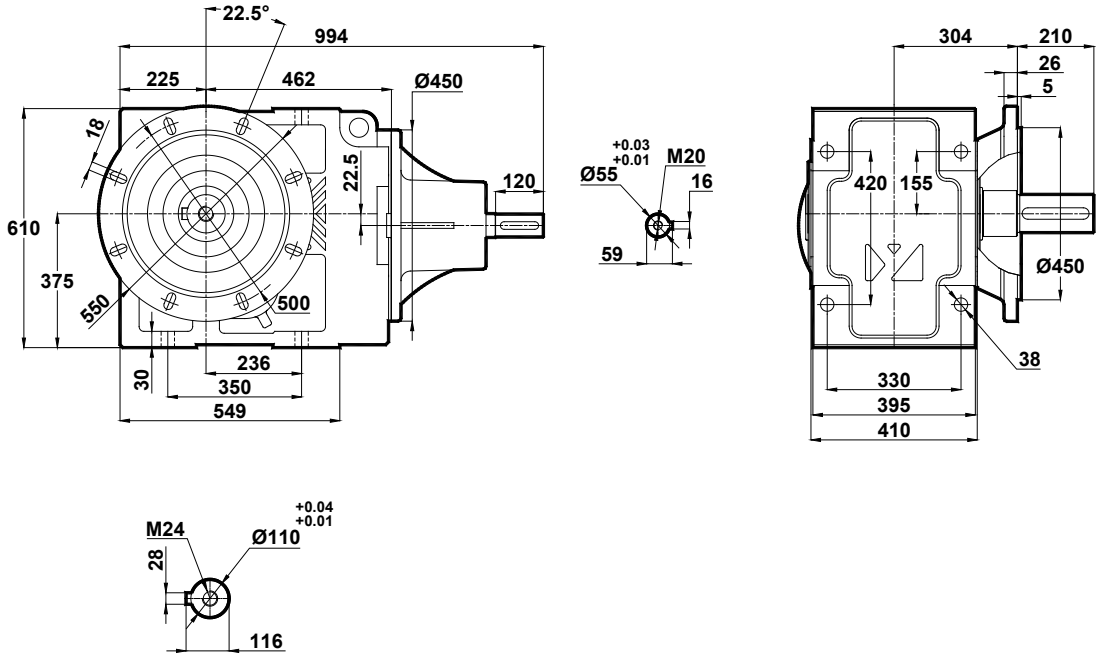

KT873.03

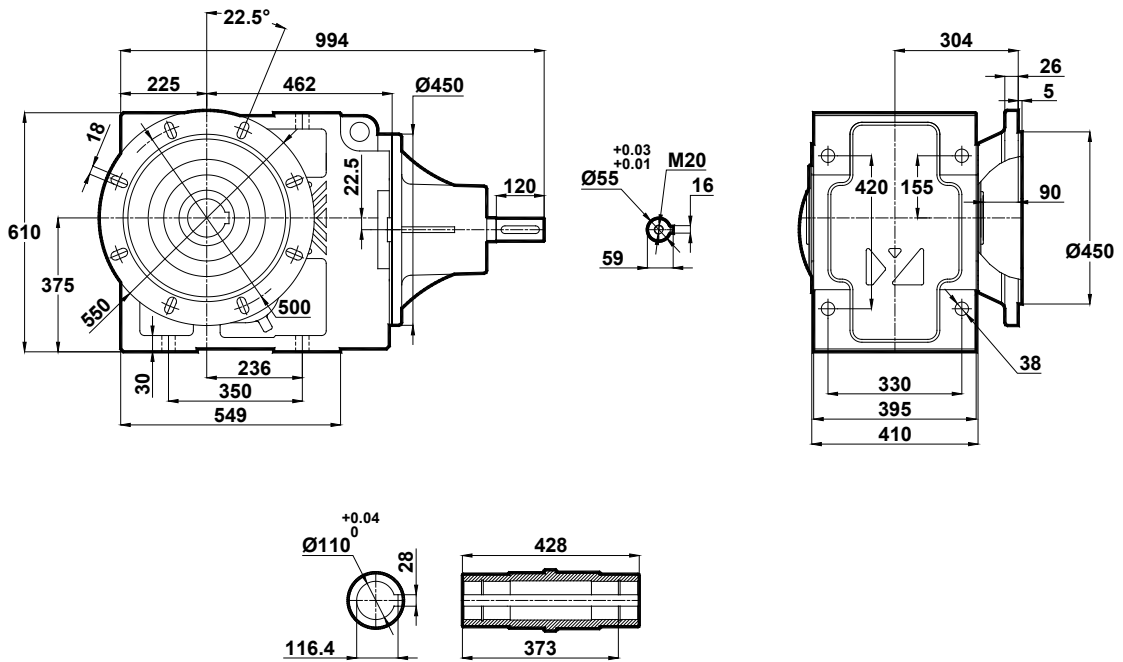

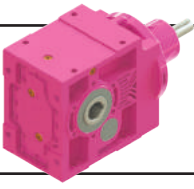

# Ölçü Sayfaları Dimension Pages Abmessungenseiten

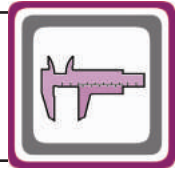

-Mil ucu çekirme deliği DIN 332 sayfa 2 / Tapped center hole to DIN 332, sheet 2 / Zentrierung mit gewinde DIN 332, Blatt 2

KT873.04

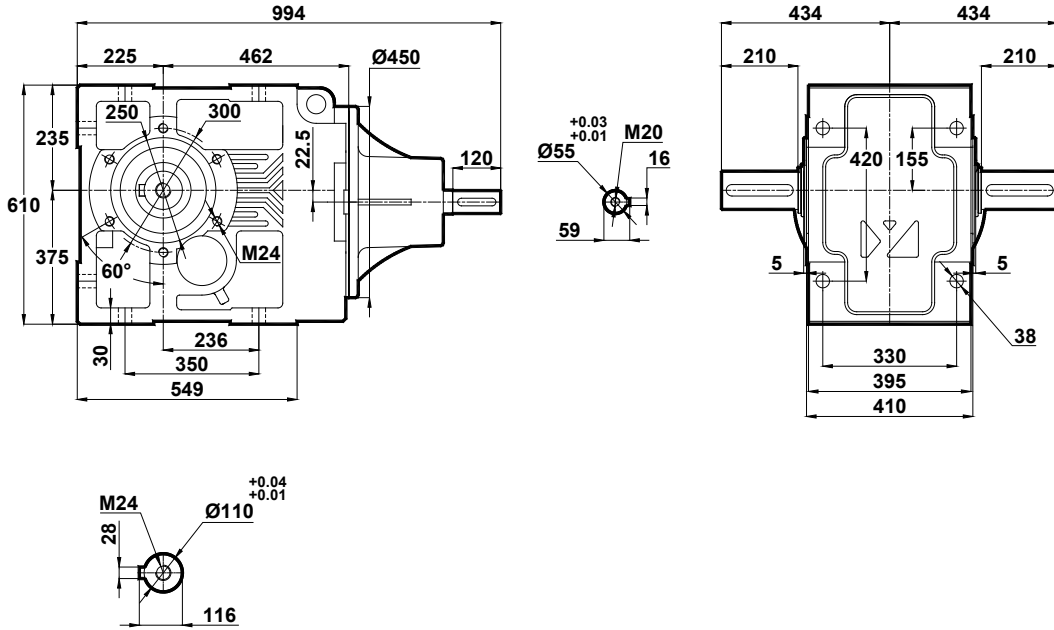

KT873.05

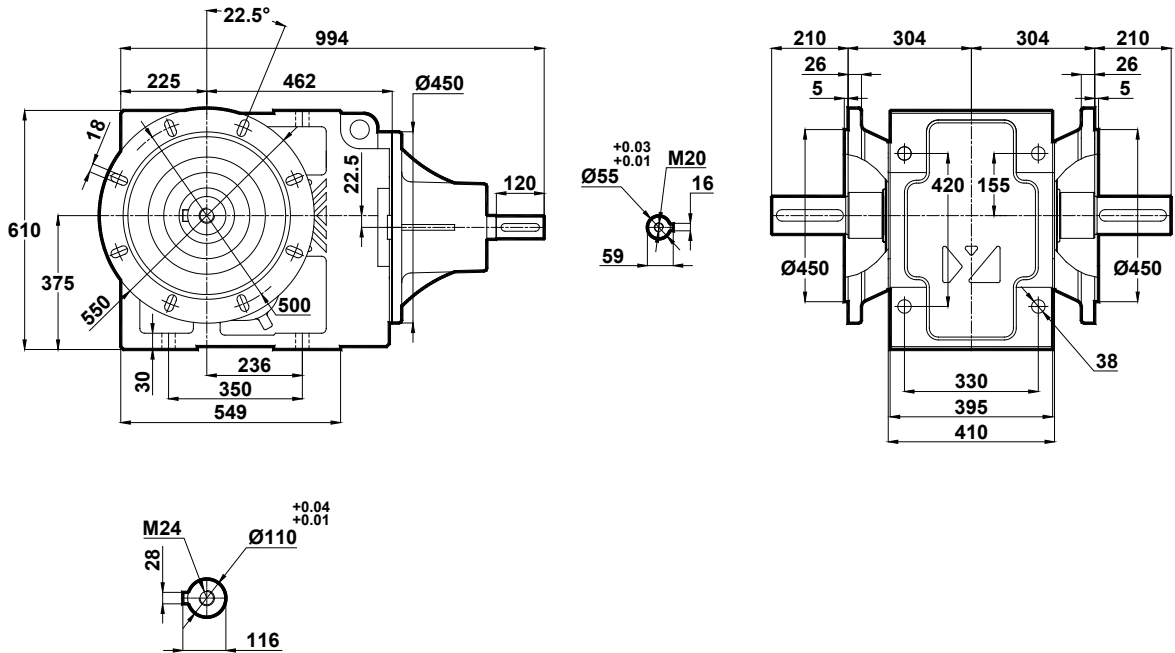

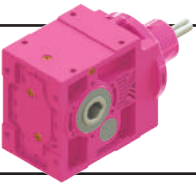

# Ölçü Sayfaları Dimension Pages Abmessungenseiten

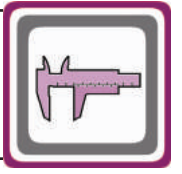

-Mil ucu çektirme deliği DIN 332 sayfa 2 / Tapped center hole to DIN 332, sheet 2 / Zentrierung mit gewinde DIN 332, Blatt 2

KT873.08

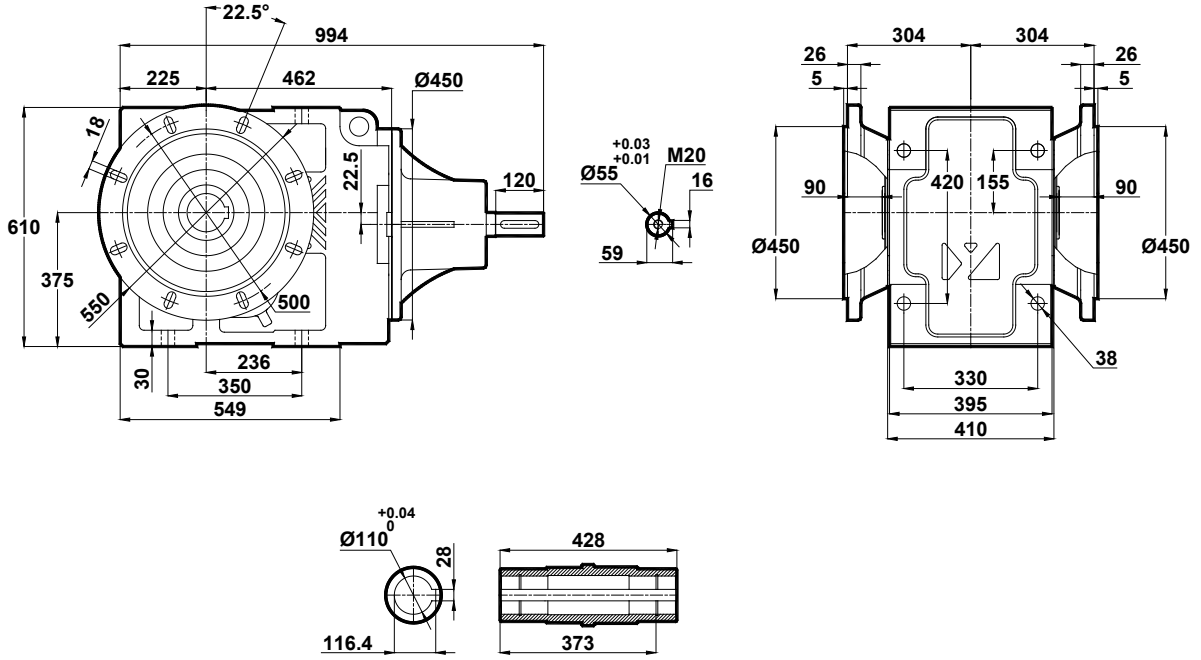

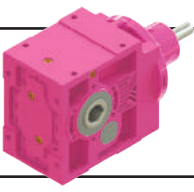

# Ölçü Sayfaları

## Dimension Pages

### Abmessungenseiten

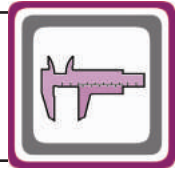

-Mil ucu çekirme deliği DIN 332 sayfa 2 / Tapped center hole to DIN 332, sheet 2 / Zentrierung mit gewinde DIN 332, Blatt 2

KT874.00

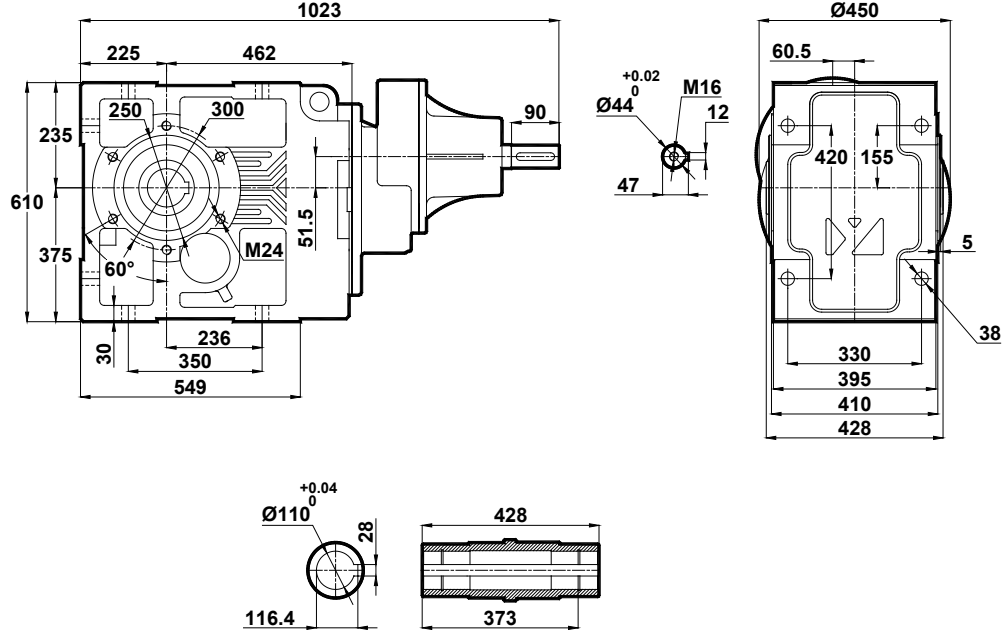

KT874.01

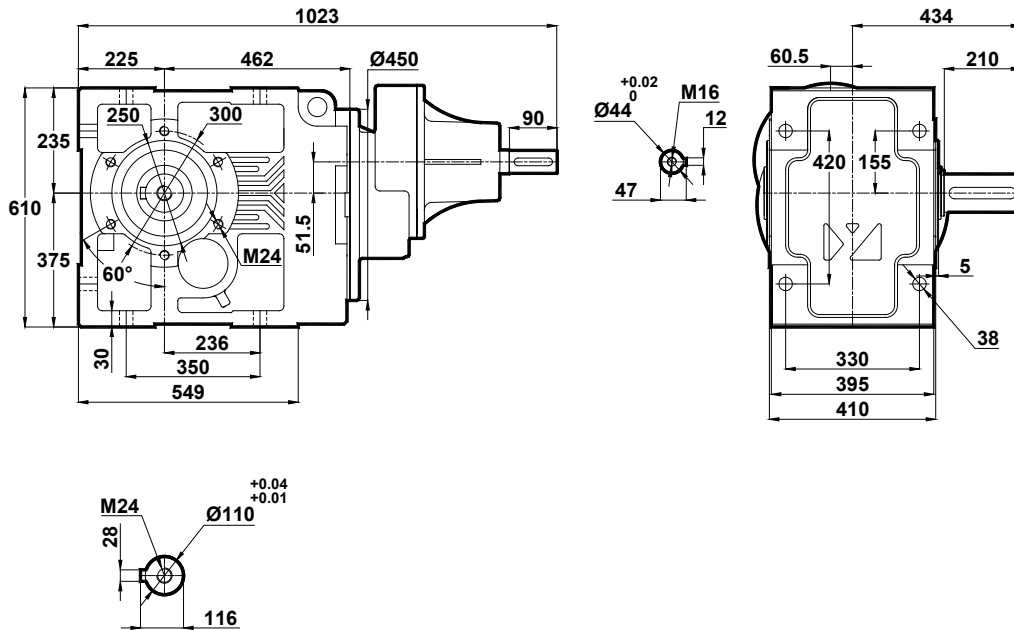

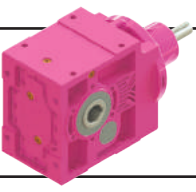

# Ölçü Sayfaları Dimension Pages Abmessungenseiten

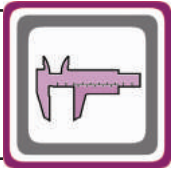

-Mil ucu çektirme deliği DIN 332 sayfa 2 / Tapped center hole to DIN 332, sheet 2 / Zentrierung mit gewinde DIN 332, Blatt 2

KT874.02

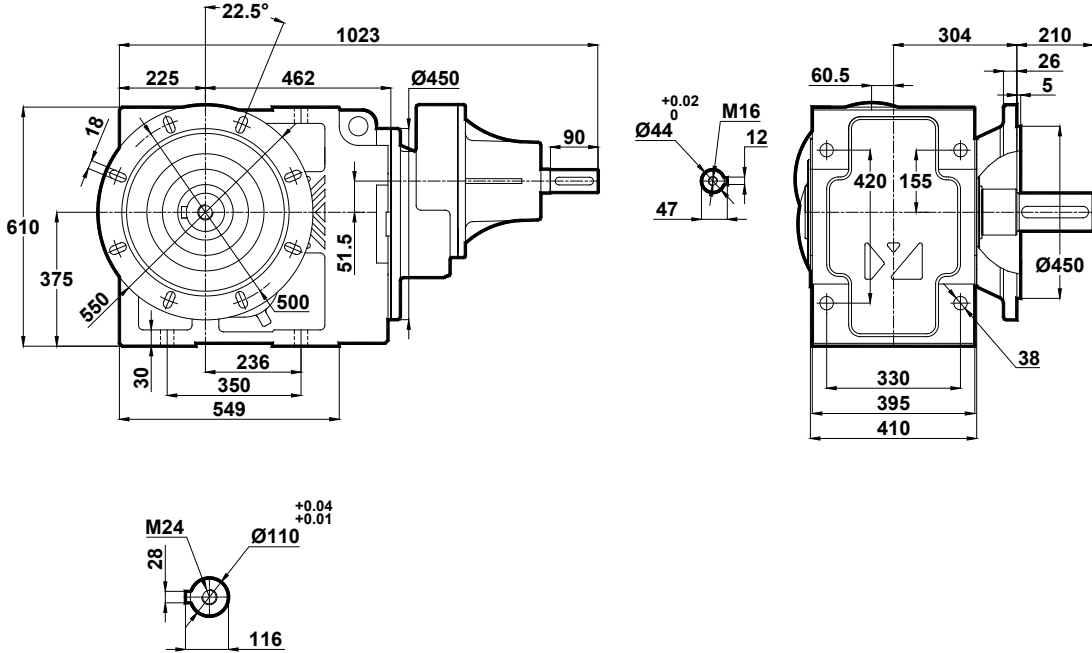

KT874.03

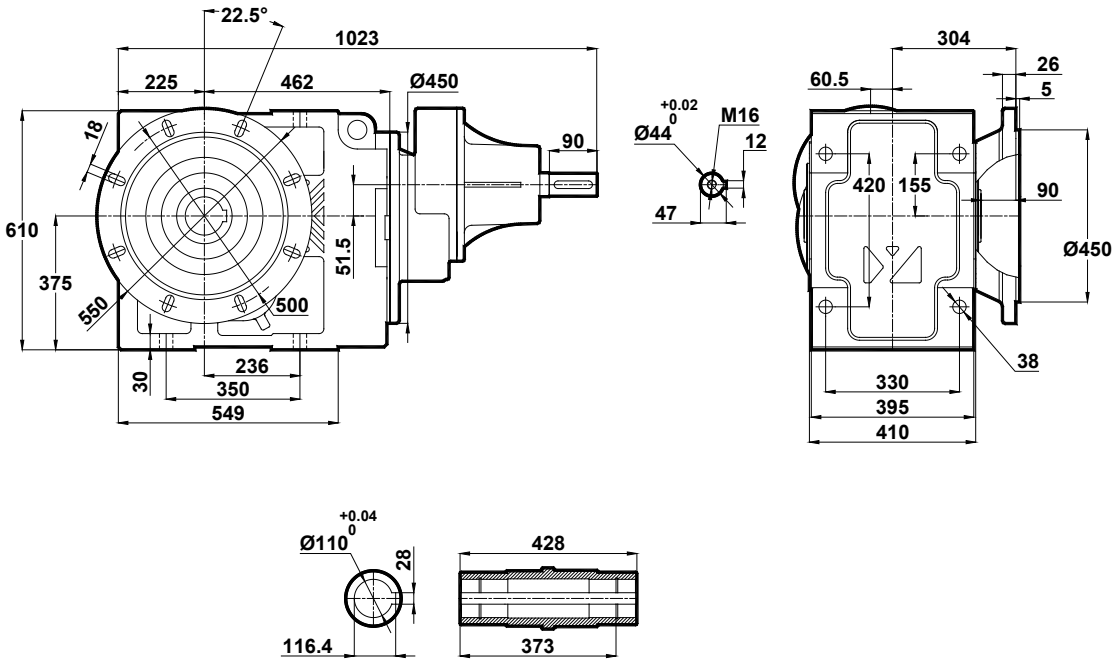

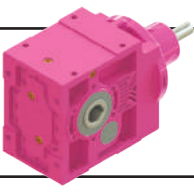

# Ölçü Sayfaları

## Dimension Pages

### Abmessungsseiten

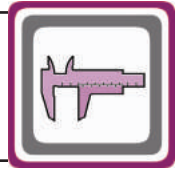

-Mil ucu çekirme deliği DIN 332 sayfa 2 / Tapped center hole to DIN 332, sheet 2 / Zentrierung mit gewinde DIN 332, Blatt 2

KT874.04

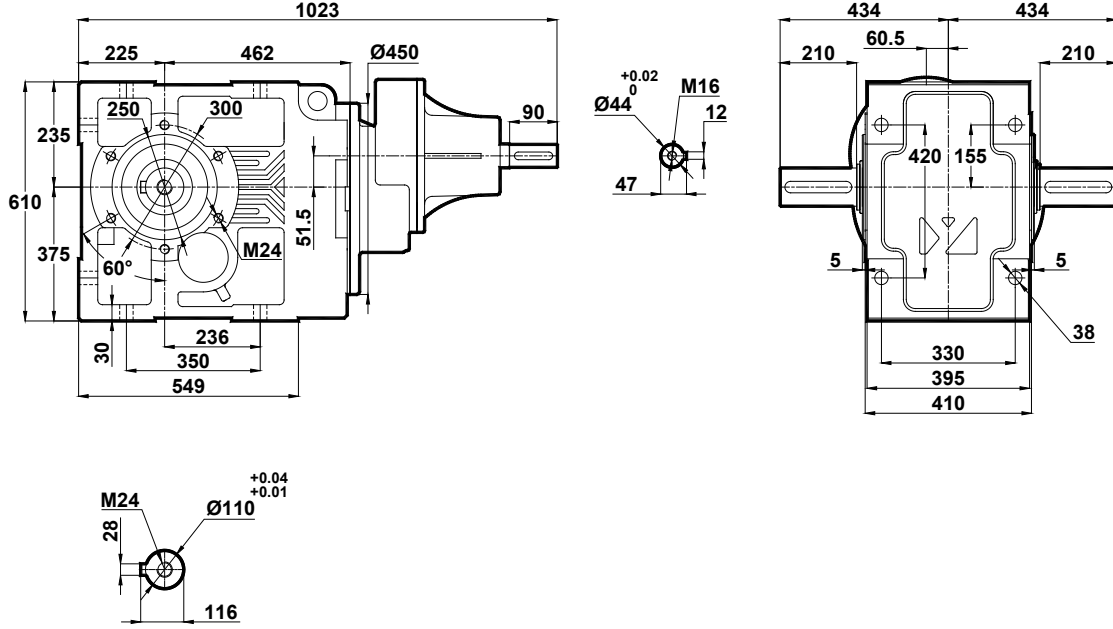

KT874.05

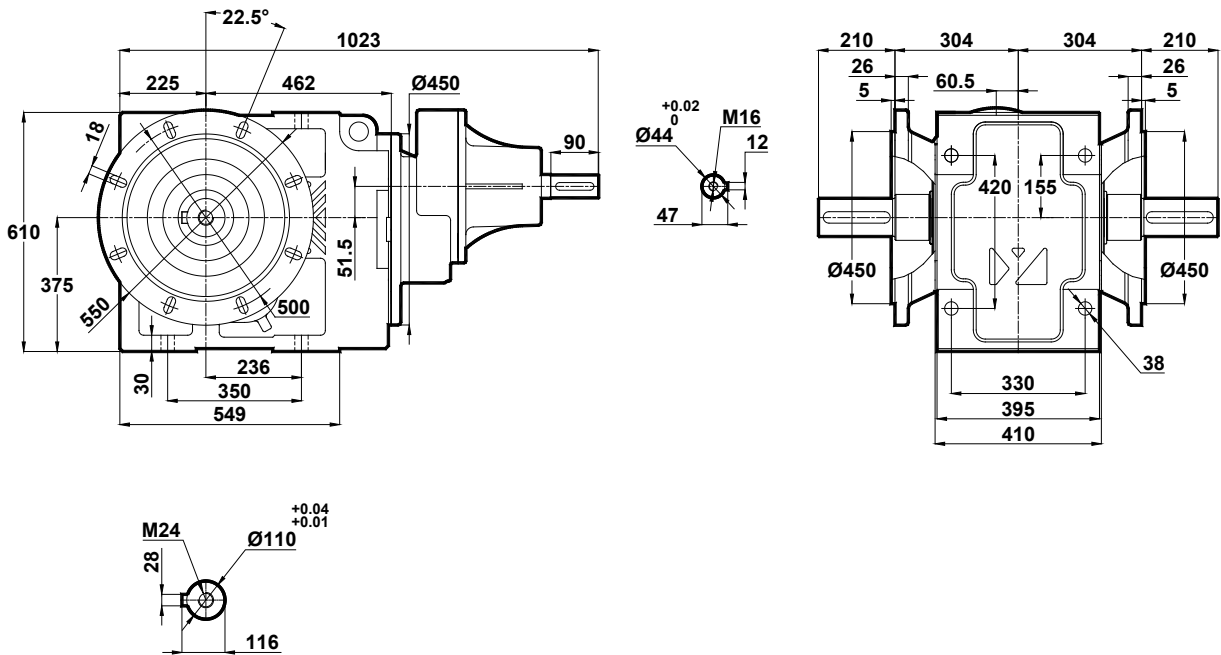

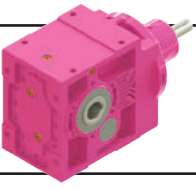

# Ölçü Sayfaları

## Dimension Pages

### Abmessungsseiten

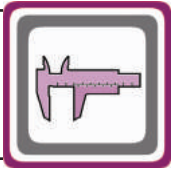

-Mil ucu çekirme deliği DIN 332 sayfa 2 / Tapped center hole to DIN 332, sheet 2 / Zentrierung mit gewinde DIN 332, Blatt 2

KT874.08

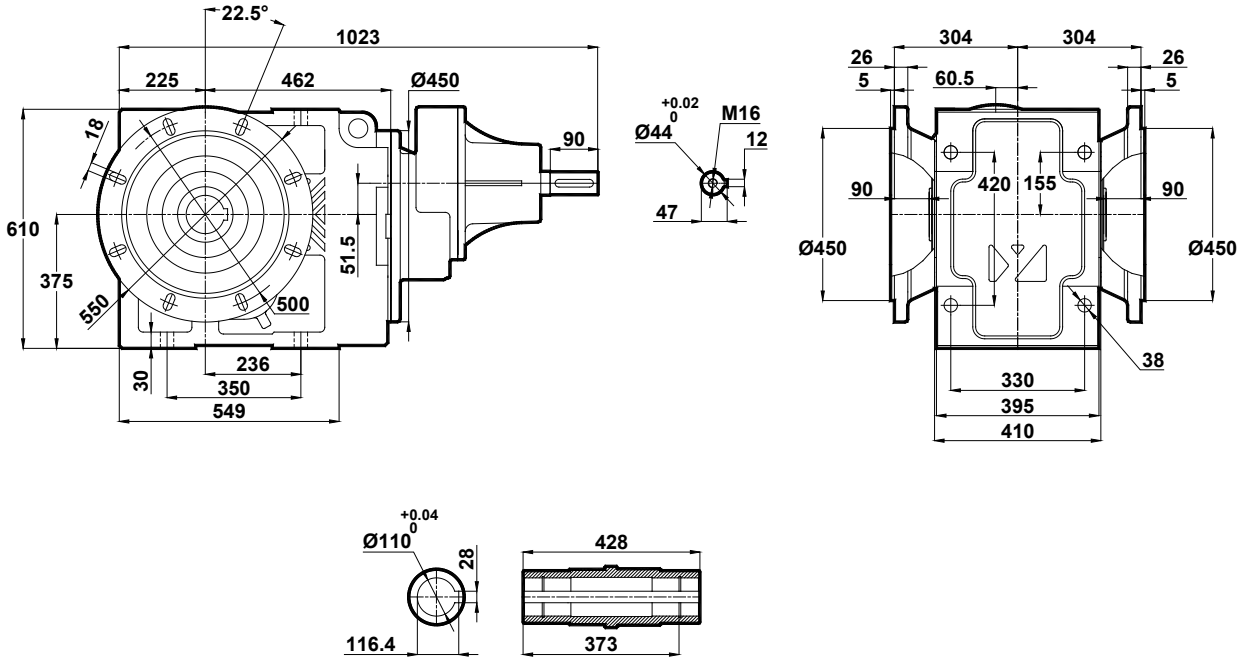



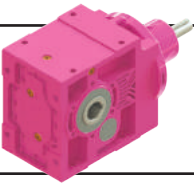

# Ölçü Sayfaları

## Dimension Pages

### Abmessungsseiten

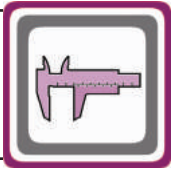

-Mil ucu çekirme deliği DIN 332 sayfa 2 / Tapped center hole to DIN 332, sheet 2 / Zentrierung mit gewinde DIN 332, Blatt 2

KT875.02  
KT876.02

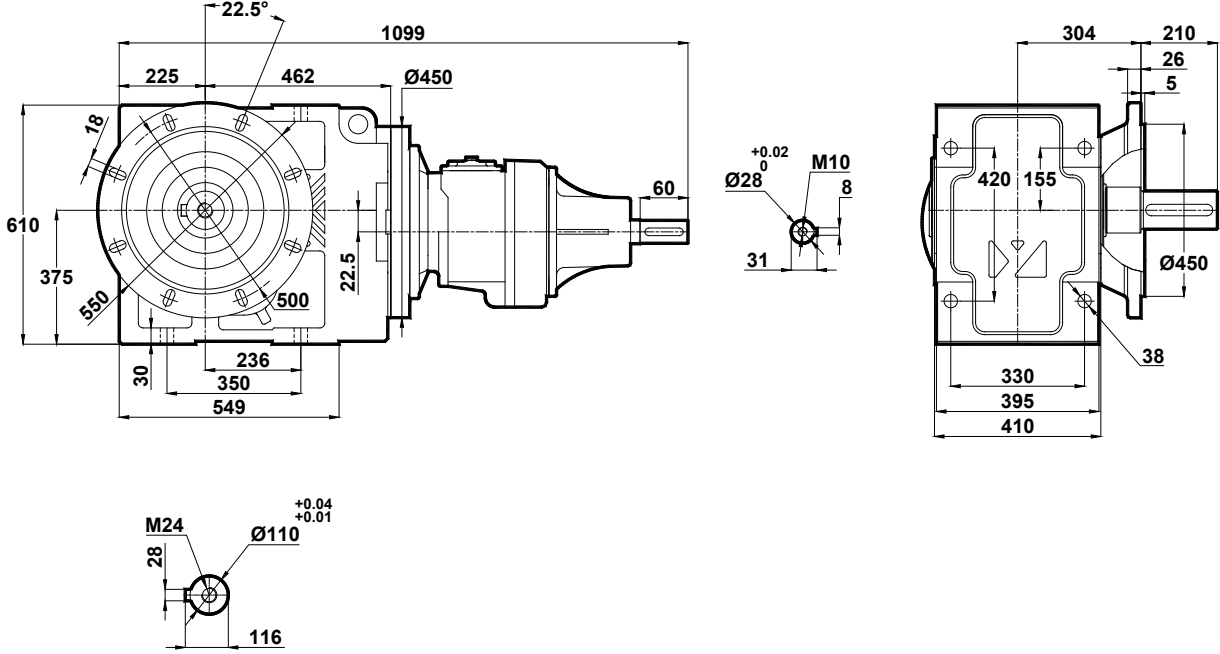

KT875.03  
KT876.03

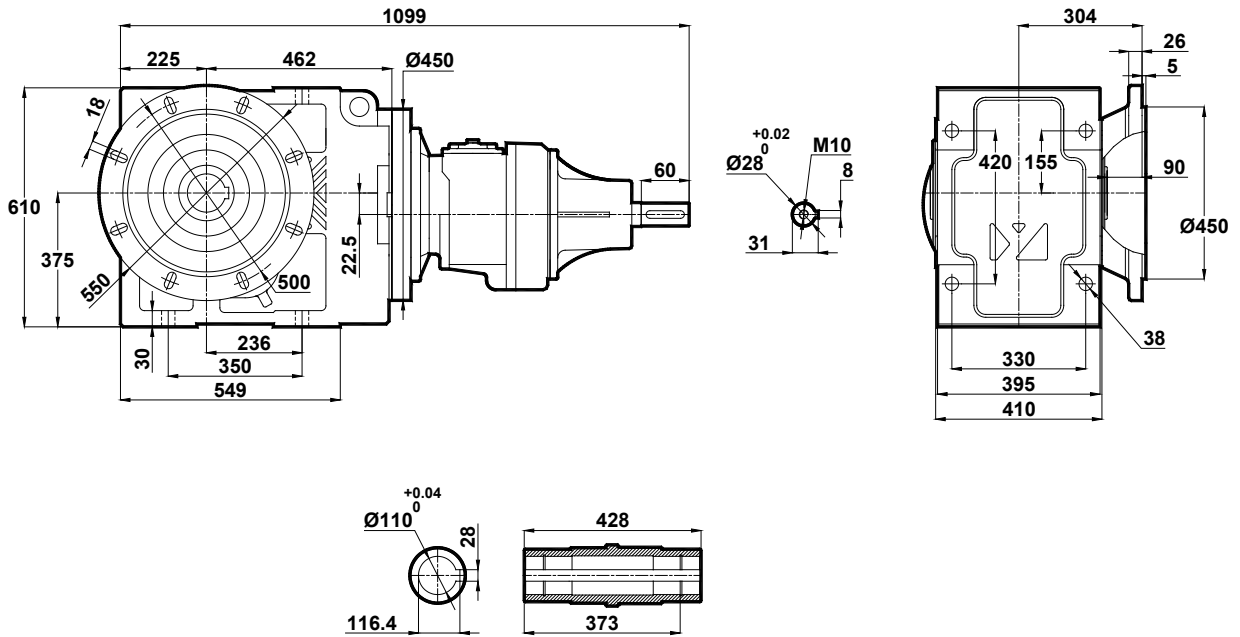

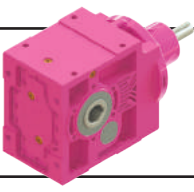

# Ölçü Sayfaları

## Dimension Pages

### Abmessungsseiten

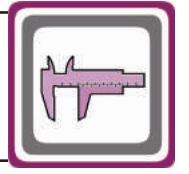

-Mil ucu çekirme deliği DIN 332 sayfa 2 / Tapped center hole to DIN 332, sheet 2 / Zentrierung mit gewinde DIN 332, Blatt 2

KT875.04  
KT876.04

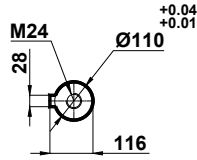
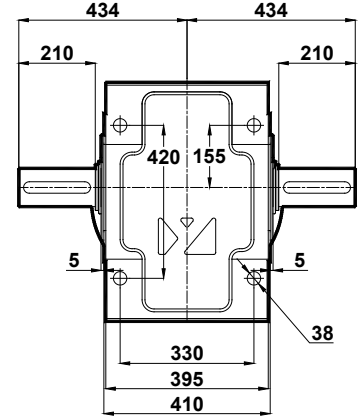
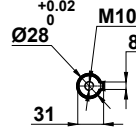
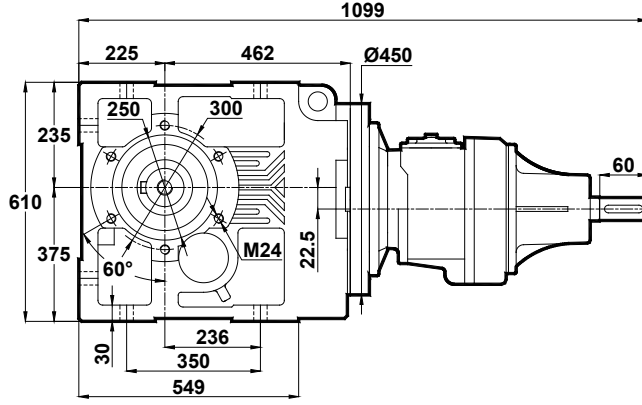

KT875.05  
KT876.05

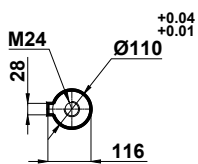
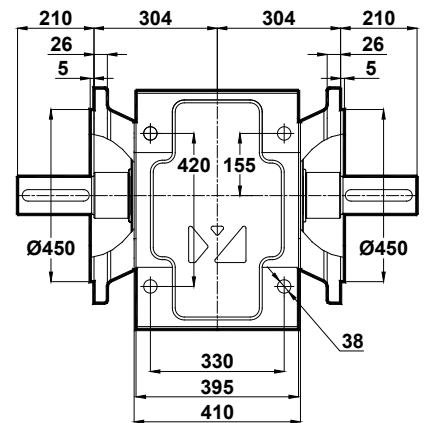
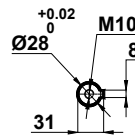
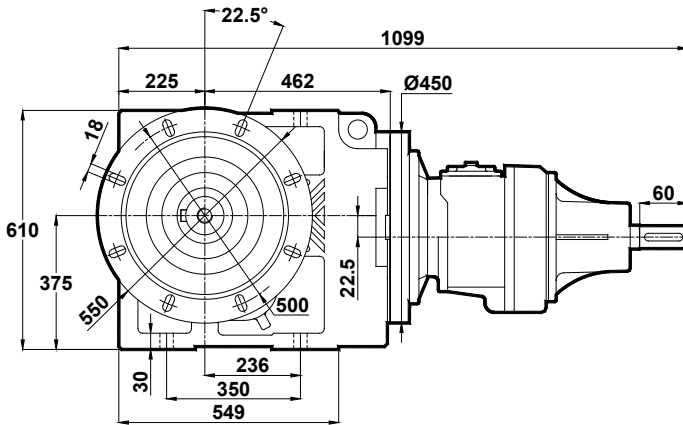



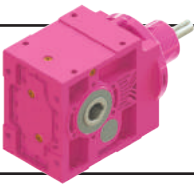

Ölçü Sayfaları  
Dimension Pages  
Abmessungsseiten

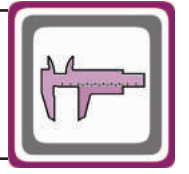

**K SERİSİ EKSTRUDER TİP REDÜKTÖRLER**  
**K SERIES EXTRUDER TYPE GEARBOXES**  
**EXTRUDER GETRIEBEN VON K SERIE GETRIEBEN**

K.27.E

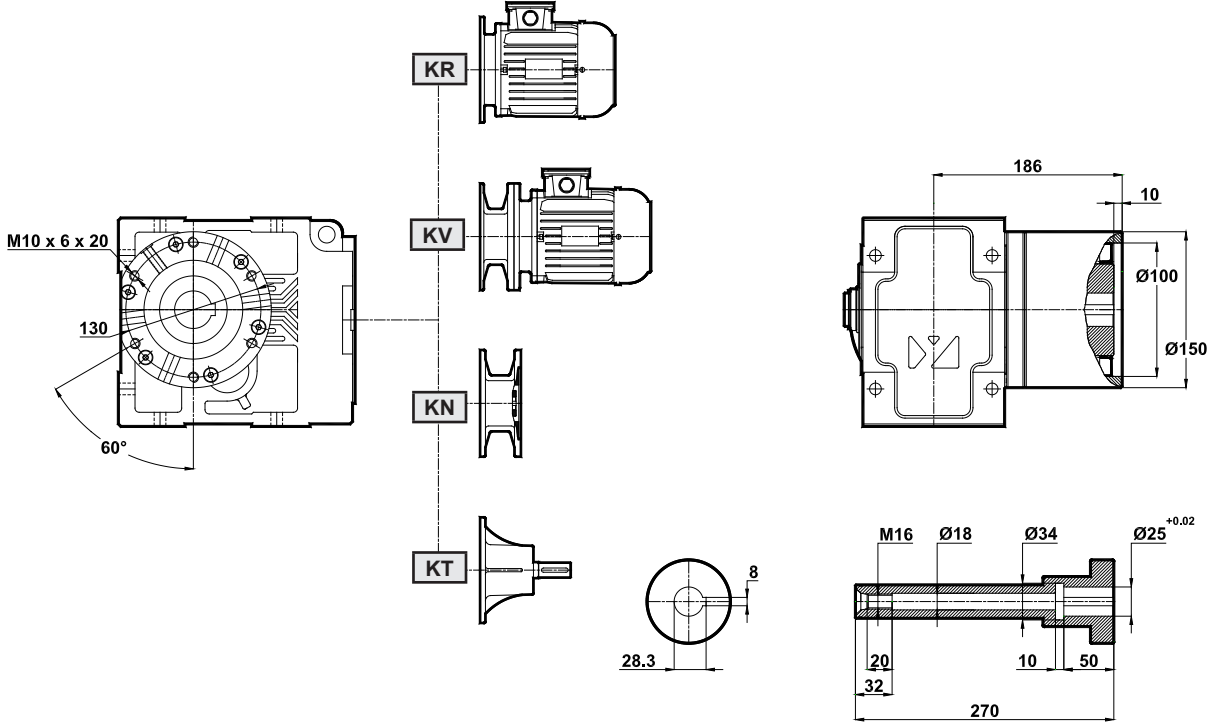

K.37.E

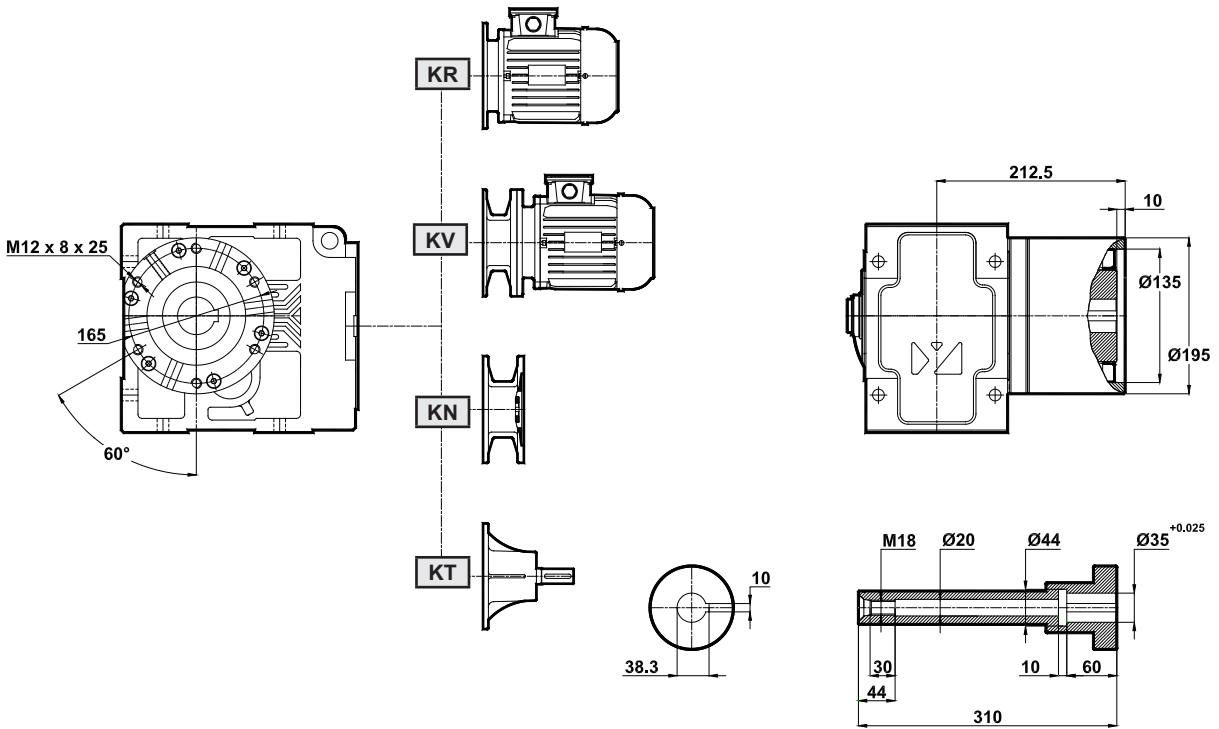

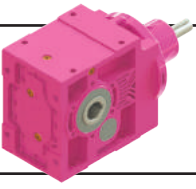

# Ölçü Sayfaları

Dimension Pages  
Abmessungsseiten

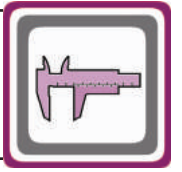

K.47.E

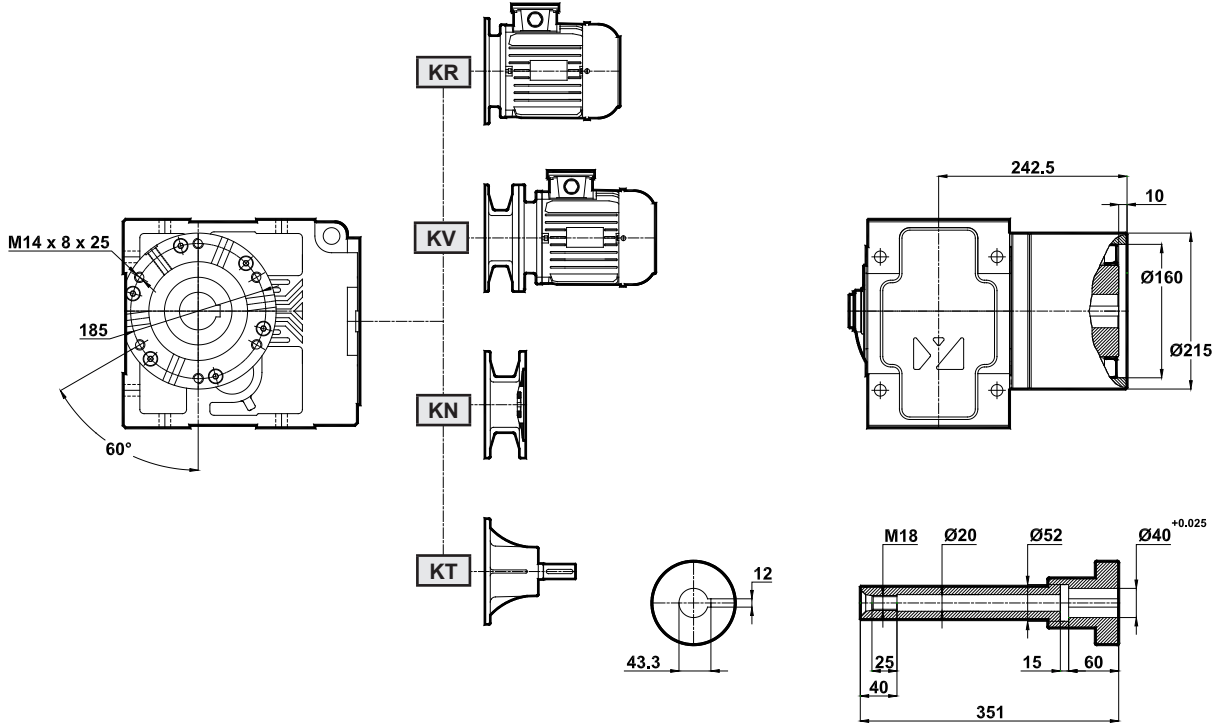

K.57.E

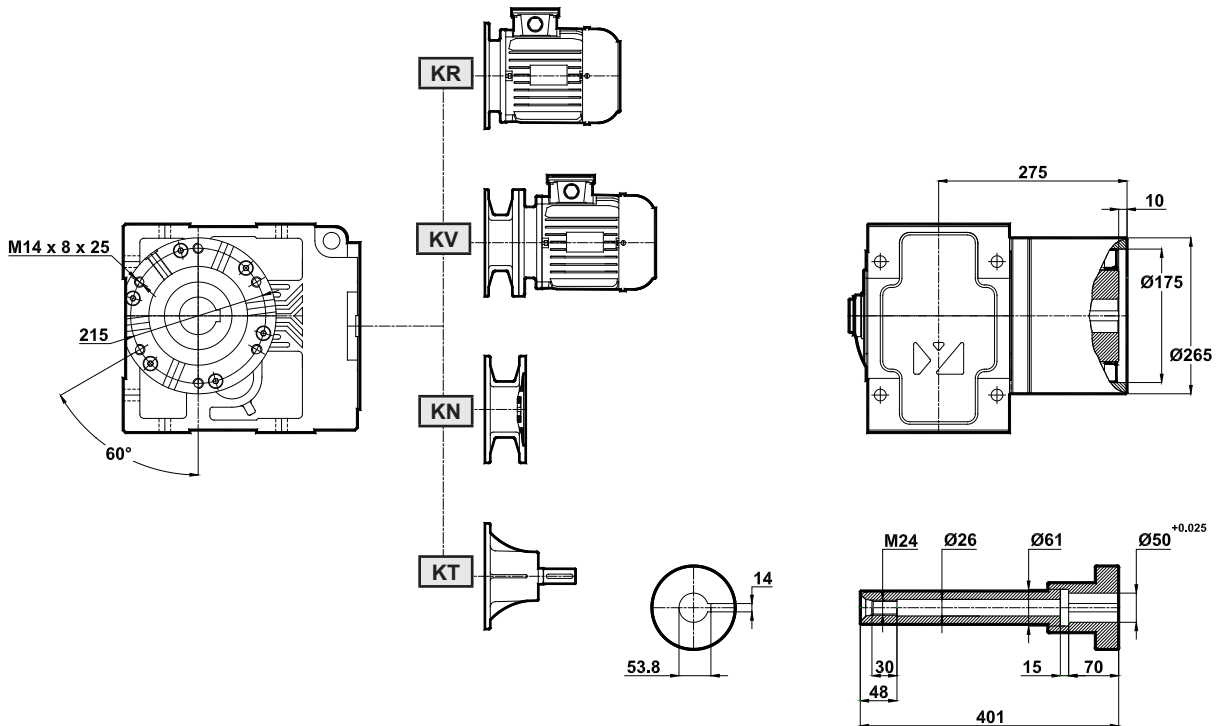

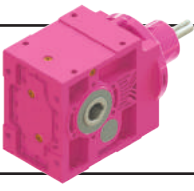

# Ölçü Sayfaları

Dimension Pages  
Abmessungenseiten

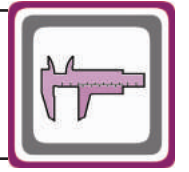

K.67.E

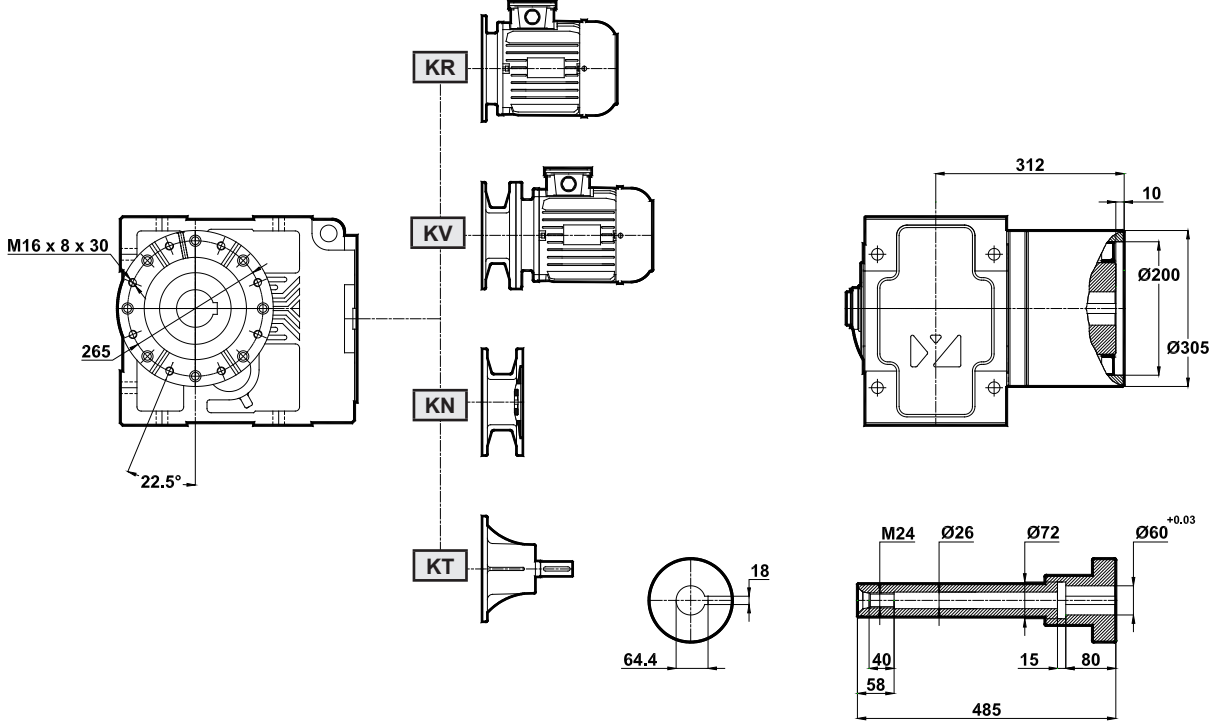

K.77.E

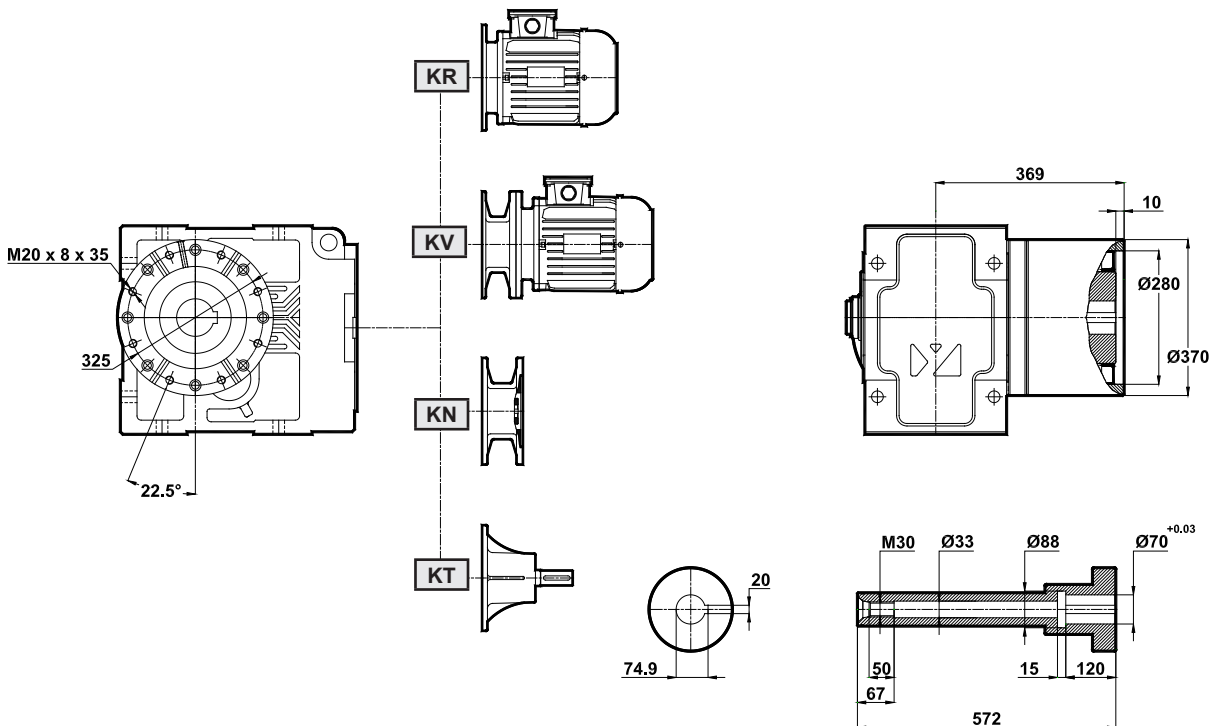

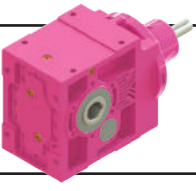

Ölçü Sayfaları  
Dimension Pages  
Abmessungenseiten

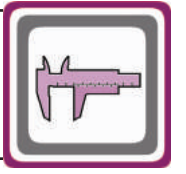

K.87.E

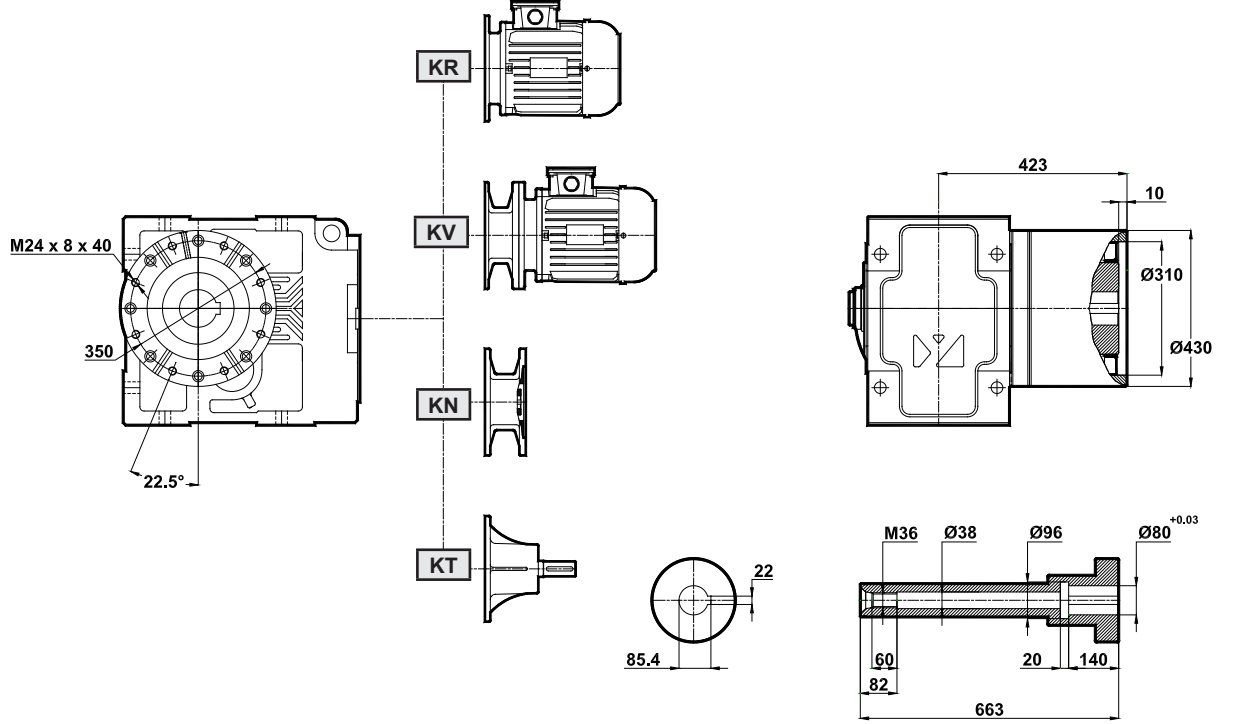

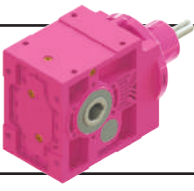

# Ölçü Sayfaları

## Dimension Pages

### Abmessungsseiten

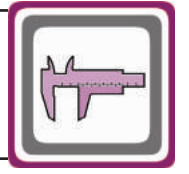

## K SERİSİ DELİK MİLLİ SIKMA BİLEZİKLİ REDÜKTÖRLER

### K SERIES HOLLOW SHAFT WITH SHRINK DISC CONNECTOR

#### K SERIE HOHLWELLE MIT SCHRUMPFSCHEIBE

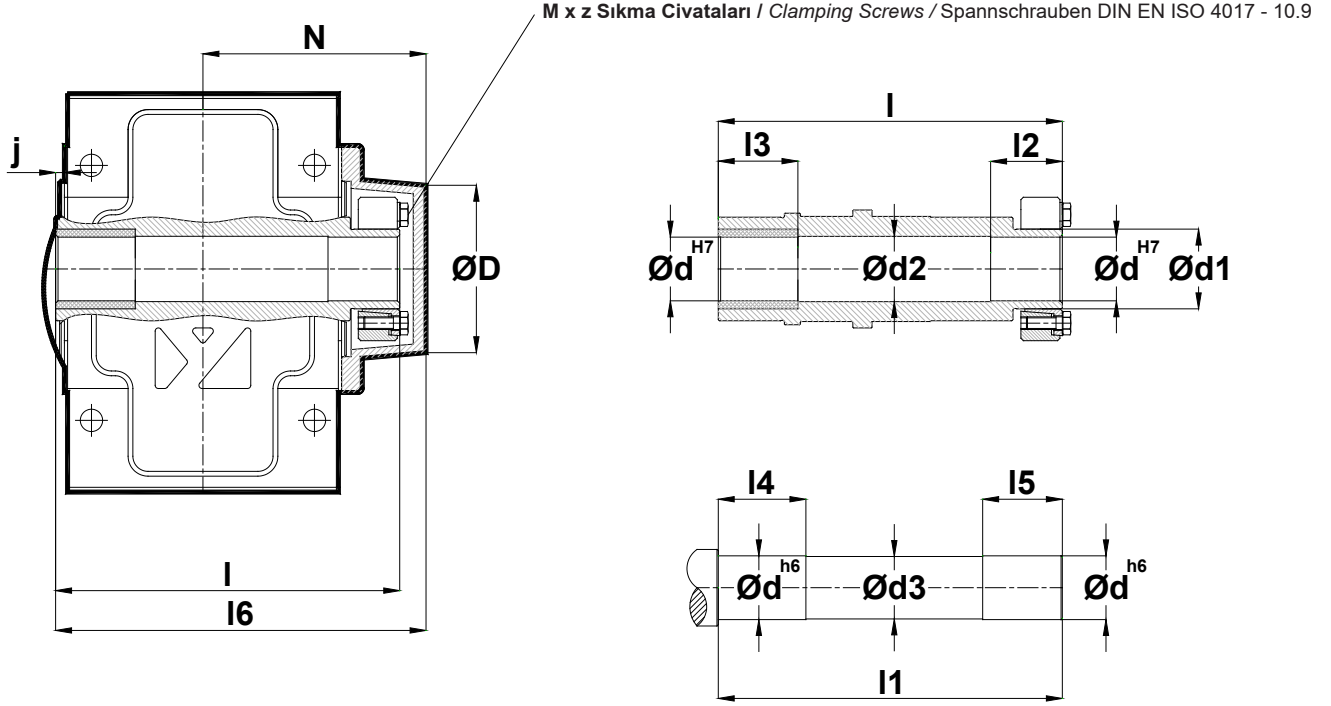

	ØD	Ød	Ød1	Ød2	Ød3	I	I1	I2	I3	I4	I5	I6	N	j	M x z	Ta [Nm]
K..00..0S	69	20	24	21	19	137	140	27	20	25	35	147	89.5	4	M6 x 5	12
K..10..0S	88	30	38	31	29	147	150	32	22	27	40	161	101	4	M8 x 5	30
K..20..0S	94	35	44	36	34	170	173	35	25	30	43	183	113	5	M8 x 6	30
K..27..0S	98	35	44	36	34	186	189	35	25	30	43	201	122.5	4.5	M8 x 6	30
K..37..0S	106	40	50	41	39	216	219	40	35	40	48	233	140.5	5.5	M8 x 8	30
K..47..0S	129	50	62	51	49	249	252	45	40	45	53	236.5	156	5.5	M8 x 9	30
K..57..0S	164	60	75	61	59	282	285	50	45	50	58	302.5	179.5	5.5	M10 x 10	59
K..67..0S	164	70	80	71	69	345	348	55	50	55	63	364	210	6	M10 x 10	59
K..77..0S	219	90	110	91	79	418	421	70	60	70	83	438.5	257	7.5	M12 x 12	100
K..87..0S	260	110	130	111	109	492	495	80	70	80	93	517	303	9	M14 x 9	160

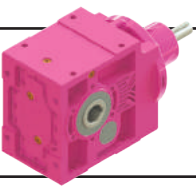

# Ölçü Sayfaları

## Dimension Pages

### Abmessungsseiten

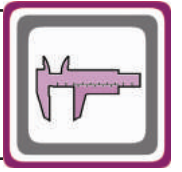

### K SERİSİ REDÜKTÖR KOVAN ÖLÇÜLERİ

#### HOLLOW SHAFT DIMENSIONS FOR K SERIES GEARBOXES

#### HOHLWELLEABMESSUNGEN VON K SERIE GETRIEBEN

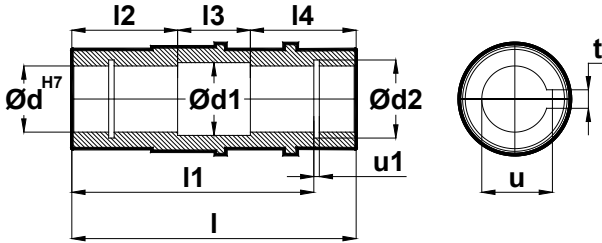

Tip Type Typ	d	d1	d2	l	l1	l2	l3	l4	u1	t	u
K.00..	20	21	21	115	100	40	35	40	1.1	6	22.8
K.10..	30	31	31.4	120	105	45	30	45	1.3	8	33.3
K.20..	35	36	36.4	140	120	55	30	55	1.6	8	38.3
K.27..	35	36	37	157	132	60	37	60	1.6	10	38.3
K.37..	40	41	42.5	185	156	70	45	70	1.85	12	43.3
K.47..	50	51	53	215	183	82	51	82	2.15	14	53.8
K.57..	60	61	63	246	210	96	54	96	2.15	18	64.4
K.67..	70	71	73	308	270	110	88	110	2.65	20	74.9
K.77..	90	91	93.5	363	313	135	93	135	3.15	25	95.4
K.87..	110	111	114	428	373	160	108	160	4.15	28	116.4

### K.27.. - K.87.. MOMENT KOLU BAĞLANTI DETAYI

#### K.27.. - K.87.. TORQUE ARM ASSEMBLY DETAILS

#### K.27.. - K.87.. DREHMOMENTSTÜTZE MONTAGE ZEICHNUNGEN

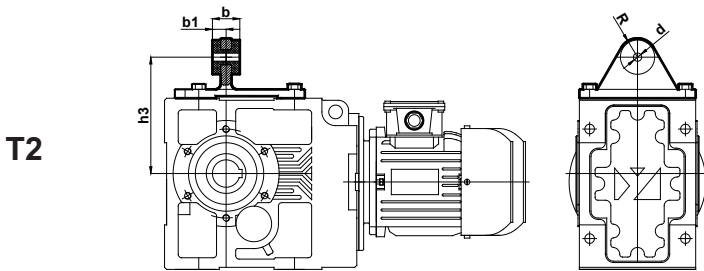
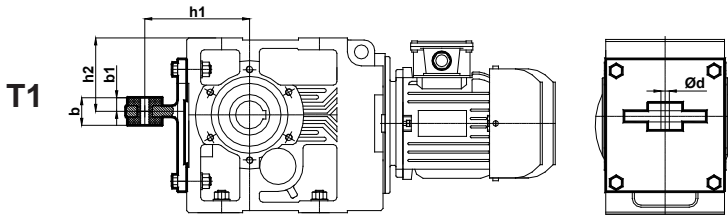
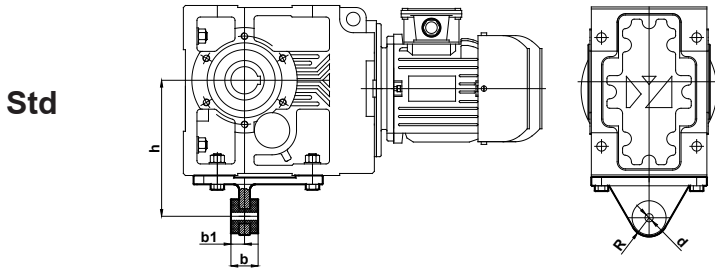

Tip / Type / Typ	Std / T1 / T2				Std.	T1	T2
	b	b1	d	R			
K.273	40	20	9	22,5	160	119	141
K.373	40	20	12	27,5	200	150	170
K.473	50	25	14	27,5	250	182	210
K.573	55	27,5	14	27,5	300	220	251
K.673	60	30	16	27,5	350	245	260
K.773	95	47,5	26	50	450	335	360
K.873	100	50	26	55	550	400	410

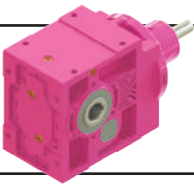

# Ölçü Sayfaları

## Dimension Pages

### Abmessungsseiten

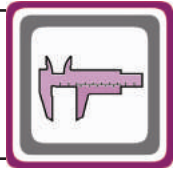

**K.00.. - K.20.. MOMENT KOLU BAĞLANTI DETAYI**  
**K.00.. - K.20.. TORQUE ARM ASSEMBLY DETAILS**  
**K.00.. - K.20.. DREHMOMENTSTÜTZE MONTAGE ZEICHNUNGEN**

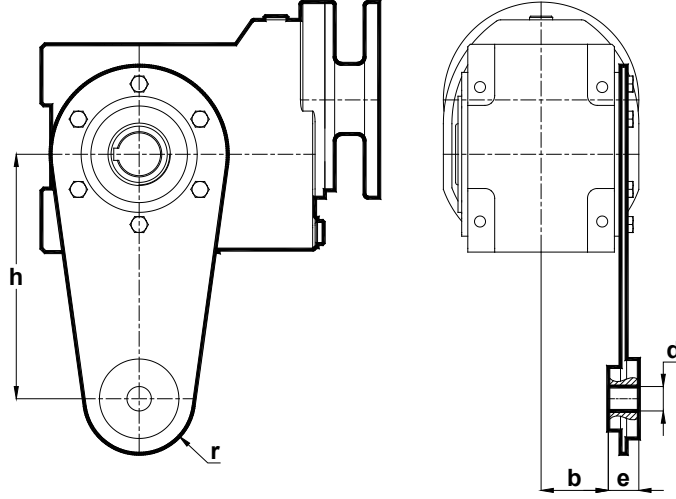

Tip /Type /Typ	b	e	d	h	R
K.00..	47	16	10	32	100
K.10..	49.5	16	10	36	150
K.20..	54.5	25	20	45	200

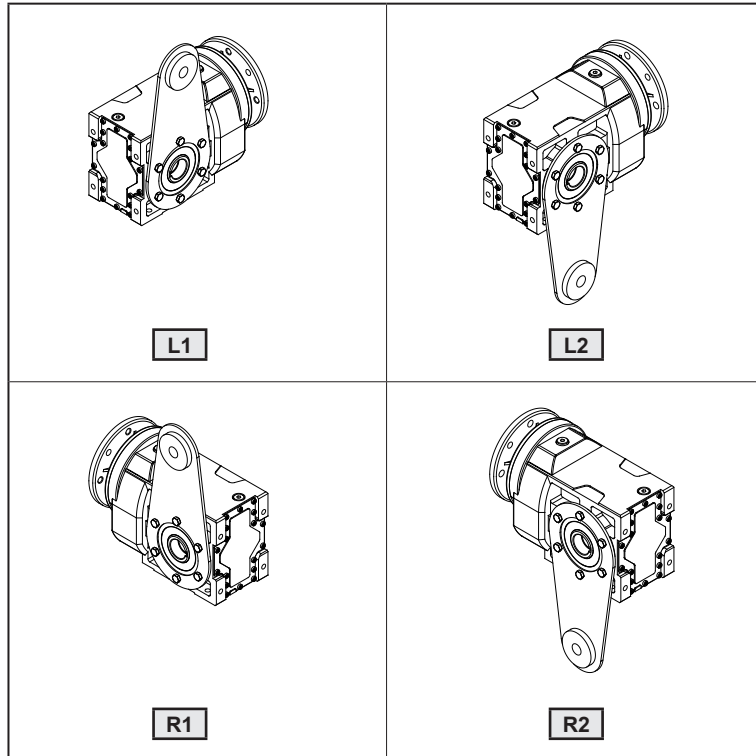

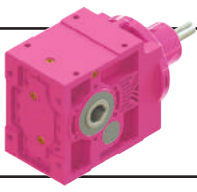

# Ölçü Sayfaları

## Dimension Pages

### Abmessungsseiten

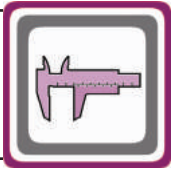

**K SERİSİ REDÜKTÖRLERDE TAVSİYE EDİLEN MİL BOYU MONTAJ-DEMONTAJ ŞEKLİ VE AKSESUARLARI**  
**ADVISED SHAFT DIMENSIONS AND ACCESORIES USED BY ASSEMBLING FOR K SERIES GEARBOXES**  
**EMPFOHLENE WELLEN MASSEN UND VERBINDUNGSELEMENTE BEI MONTAGE FÜR K SERIE GETRIEBE**

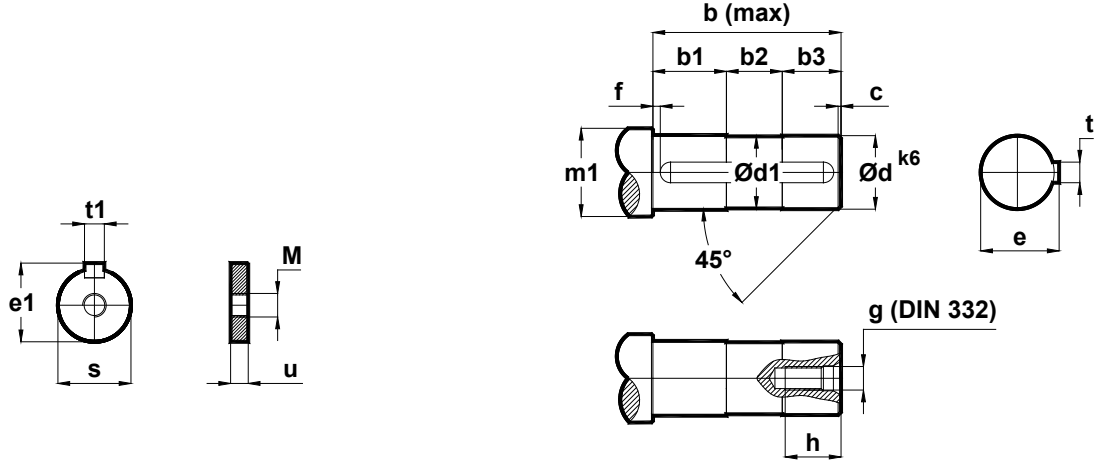

Tipi Type Typ	s	u	e1	t1	M	d	d1	m1	f	b	b1	b2	b3	c	g	h	e	t
K.00..	19.7	10	22	5.5	M10	20	19	24	5	86	45	25	16	0.5	M6	18	22.5	6
K.10..	29.7	10	33	7.5	M12	30	29	36		90	50	20	20	1	M10	24	33	8
K.20..	34.7	12	38	9.5	M16	35	34	43		102	60	20	22	1	M12	30	38	10
K.27..	34.7	12	38	9.5	M16	35	34	43		114	65	27	22	1	M12	30	38	10
K.37..	39.7	12	43	11.5	M20	40	39	50		138	75	35	28	2	M16	38	43	12
K.47..	49.7	12	53.5	13.5	M20	50	49	60		165	87	41	37	3	M16	38	53.5	14
K.57..	59.7	16	64	17.5	M24	60	59	75		188	101	44	43	3	M20	44	64	18
K.67..	69.7	16	74.5	19.5	M24	70	69	85		248	115	78	55	4	M20	44	74.5	20
K.77..	89.7	20	95	24.5	M30	90	89	110		287	140	83	64	4	M24	52	95	25
K.87..	109.7	20	116	27.5	M30	110	109	130		347	165	98	84	4	M24	52	116	28

Mil Çektirme / Shaft Mounting / Einziehen

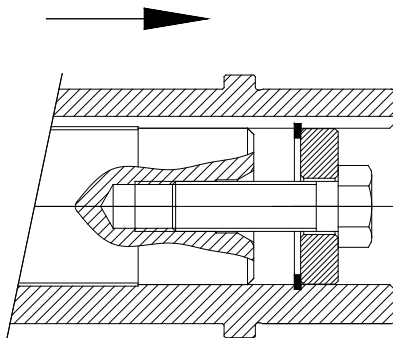

Mil Çıkartma / Shaft Pulling Out / Heraus Drücken

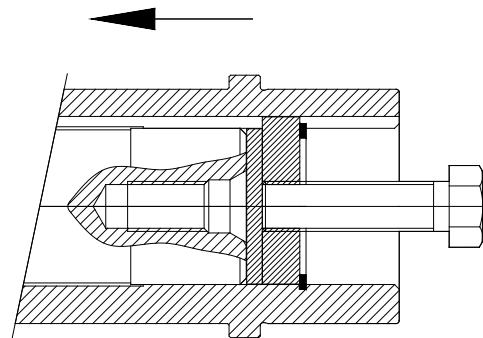

**6 Köşe Başlı Civata / 6 Contour Bolt / Sechskantschraube**  
(DIN ISO 4014 . DIN ISO 4017)  
(DIN ISO 8765)

